

Technical Information

- CV** Check Valves
- SH** Shuttle Valves
- LM** Load/Motor Controls
- FC** Flow Controls
- PC** Pressure Controls
- LE** Logic Elements
- DC** Directional Controls
- MV** Manual Valves
- SV** Solenoid Valves
- PV** Proportional Valves
- CE** Coils & Electronics
- BC** Bodies & Cavities
- TD** Technical Data

General Description

2-Way, 2 Position, Normally Closed, Bi-Directional Poppet Valve. For additional information see Technical Tips on pages SV1-SV6.

Features

- Built-in thermal relief set at 36 Bar (500 PSI) above rated pressure
- One piece cartridge housing ensures internal concentricity
- Coil: Waterproof, hermetically sealed, requires no O'Rings; Coil is interchangeable with O2 and O4 series poppet valves; Symmetrical coil can be reversed without affecting performance.

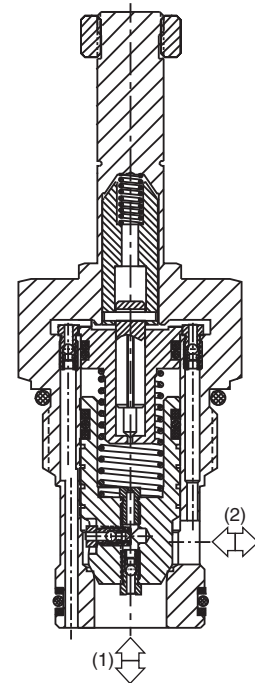
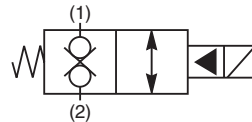
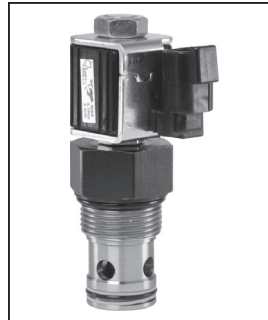

Specifications

Rated Flow	285 LPM (75 GPM)
Maximum Inlet Pressure	80 210 Bar (3000 PSI) 81 350 Bar (5000 PSI)
Leakage at 150 SSU (32 cSt)	9 drops/min. (.58 cc/min.)
Minimum Operating Voltage	85% of rated voltage at 20°C (72°F).
Response Time	See Performance Curves
Cartridge Material	All parts steel. All operating parts hardened steel.
Operating Temp. Range/Seals	-34°C to +121°C (Nitrile) (-30°F to +250°F) -26°C to +204°C (Fluorocarbon) (-15°F to +400°F)
Fluid Compatibility/Viscosity	Mineral-based or synthetic with lubricating properties at viscosities of 45 to 2000 SSU (6 to 420 cSt)
Filtration	ISO 4406 18/16/13, SAE Class 4
Approx. Weight	0.4 kg (.88 lbs.)
Cavity	C16-2 (See BC Section for more details)

Performance Curves

Pressure Drop vs. Flow (Through cartridge only)

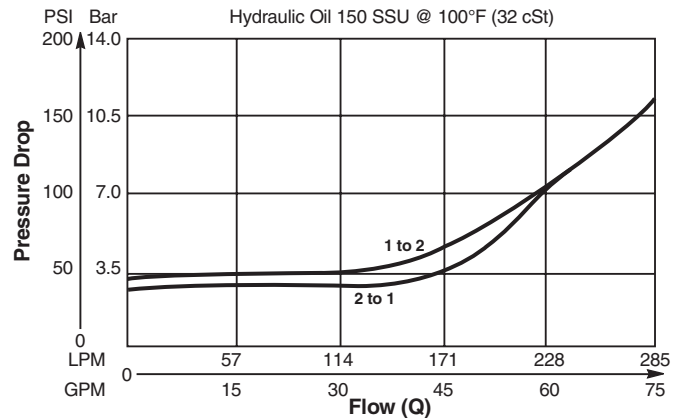

Response Time vs. Flow

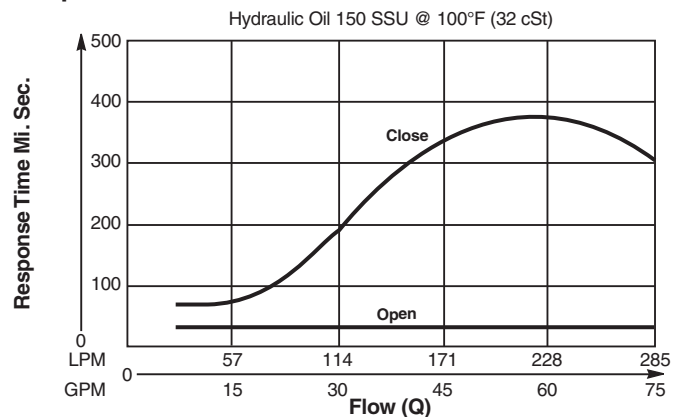

Dimensions Millimeters (Inches)

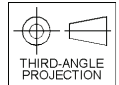
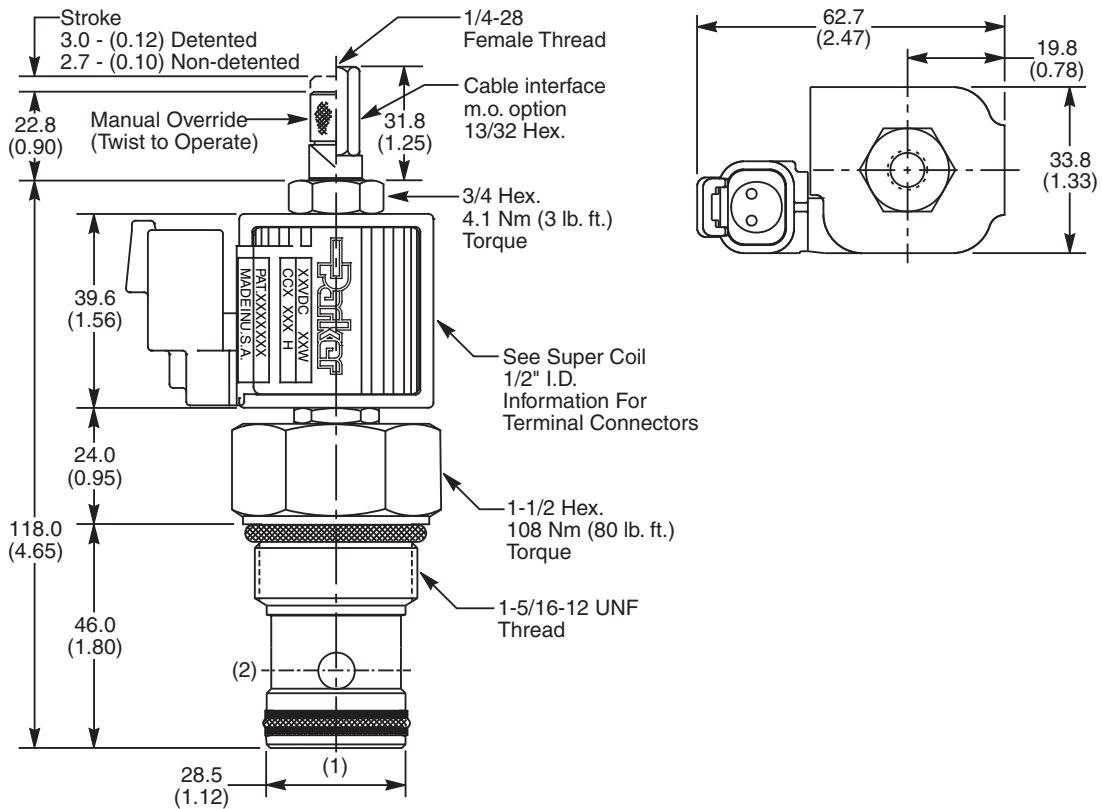

Ordering Information

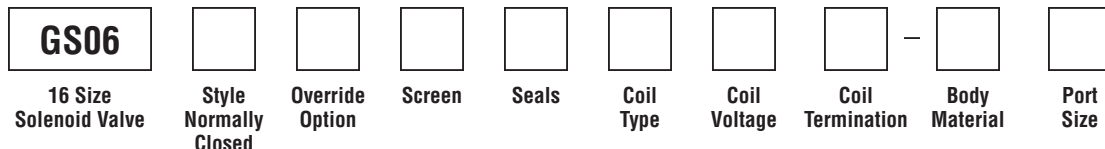

Code	Style
80	Standard ('SS' Coil)
81	High Pressure ('SP' Coil)

Code	Seals / Kit No.
N	Nitrile / Buna-N (Std.) (SK30089N-1)
V	Fluorocarbon / (SK30089V-1)

Code	Coil Termination
Omit	Without Coil
A	Amp Jr. Timer*
C	Conduit With Leads
D	DIN Plug Face
H	Molded Deutsch*
L	Dual Lead Wire*
PF	Packard Female*
PM	Packard Male*
S	Dual Spade*

Code	Body Material
Omit	Steel
A	Aluminum

Code	Override Options
0	None
1	Detented
2	Non-Detented
3	Cable Interface 210 Bar (3000 PSI)

Code	Coil Type
Omit	Without Coil
SS	Super Coil - 14 Watts
SP	Super Coil - 19 Watts

Code	Port Size	Body Part No.
Omit	Cartridge Only	
16T	SAE-16	(B16-2-*16T)

* Add "A" for aluminum, omit for steel.

Code	Screen
0	None

Code	Coil Voltage
Omit	Without Coil
D012	12 VDC
D024	24 VDC
A120	120 VAC, 60/50 Hz

See Super Coil 1/2" I.D.
 *DC Only