

Hydraulic Motors - Overall Instructions

M5AS / M5ASF

Denison Vane Technology, fixed displacement

aerospace
climate control
electromechanical
filtration
fluid & gas handling
hydraulics
pneumatics
process control
sealing & shielding



ENGINEERING YOUR SUCCESS.

Table of contents

1 . START UP INSTRUCTIONS & RECOMMENDATIONS

1 . 1 . General, start up & check up 3
 1 . 2 . Shaft & coupling data 5
 1 . 3 . Specific points 6 - 7
 1 . 4 . Fluids 7
 1 . 5 . Seals 7

2 . MOTOR & CARTRIDGE EXPLODED VIEWS 8

3 . CONVERSIONS

3 . 1 . Disassembly / Assembly 9 to 19
 3 . 1 . a Changing cartridge 9 to 11
 3 . 1 . b Changing displacement (cam ring) 12
 3 . 1 . c Changing shaft 13 to 14
 3 . 1 . d Assembly 15 to 18
 3 . 2 . Changing rotation 19 to 23
 3 . 3 . Changing porting orientation 24 to 26
 3 . 4 . Valves 27 to 28

4 . KEY SHEET

4 . 1 . Key sheet 29
 4 . 2 . Porting tables 30
 4 . 3 . Tightening torque requirements 30

5 . SPECIAL TOOLS

5 . 1 . Seal driver - Dimensions 31

6 . COUPLINGS

6 . 1 . Female coupling dimensions 31

7 . TROUBLESHOOTING GUIDE 32 to 33

NOTES 34

WARNING 35

1.1. GENERAL :

All Parker vane motors are individually tested to provide the best quality & reliability. Modifications, conversions & repairs can only be done by authorized dealers or OEM to avoid invalidation of the guarantee.

The motors are to be used within the design limits indicated in our sales bulletins. Please contact Parker when trespassing the catalogue limits.

Do not modify or work on the motor when it is under pressure.

Qualified personnel is required to assemble and set-up hydraulic devices.

Always conform yourself to the valid regulations (safety, electrical, environment...).

The following instructions are important to obtain a good service life time from the unit.

Internal parts of the motor are lubricated by the operating fluid itself ; therefore, preventive maintenance is limited to keep the fluid clean in the system, and within acceptable viscosity range.

The system filters should be replaced frequently. When possible, dirt should not be allowed to accumulate on the motor or around the shaft seal. Check frequently that all fittings and bolts are tight at correct torque.

ROTATION & PORTS INDICATION

The rotation way and ports orientation are viewed from the shaft end.

R = CW stands for clockwise = right-hand rotation.

A inlet, B outlet

L = CCW stands for counter-clockwise = left-hand rotation.

A inlet, B outlet

N = Stands for bi-rotational, A inlet, B outlet = R (CW)

B inlet, A outlet = L (CCW)

DESCRIPTION

The M5AS* series is a new design of vane motor. It has been designed especially for severe duty applications which require high pressure, up to 280 bar (4060 PSI). The 12 vanes patented cartridge allows very low noise level whatever the speed is, a low torque ripple, and high efficiencies.

The M5AS* single vane motor consists of five basic components :

- the housing (housing and shaft seal)
- the pressure plate (plate, ball, adaptor and screw)
- the cartridge (cam ring, rotor, vanes and springs)
- the end cap (cap and needle bearing)
- the shaft assembly (shaft, ball bearing, retaining ring and key)

The design of the Parker motors allows to change the cartridge, to renew the motor or to change the displacement to suit altered requirements for speed or torque.

APPLICATIONS

The M5AS* motor has a stiff taper or cylindrical shaft and a high load capacity double ball bearing, and allows direct mounting on shaft (fan, belt drive, chain drive).

For uni-directional applications, the M5AS* is fitted with an internal valve which allows smooth dynamic braking, with a very simple hydraulic circuit, without risk of motor cavitation.

OPERATION

Operation of these rugged hydraulic motors is simple. The motor shaft is driven by the rotor. Vanes, closely fitted into the rotor slots, move radially to seal against the cam ring. The ring has two major and two minor radial sections joined by transitional sections called ramps. These contours and the pressures exposed to them are balanced diametrically.

Light springs urge the vanes radially against the cam contour, assuring a seal at zero speed, so that the motor can develop starting torque. The springs are assisted by the centrifugal force at higher speeds. Radial grooves and holes through the vanes equalize hydraulic forces on the vanes at all times.

Fluid enters and leaves the motor cartridge through openings in the side plates at the ramps. Each motor port connects the two diametrically opposed ramps.

The rotor is axially separated from the sideplate surfaces by the film of oil. The front sideplate is clamped against the cam ring by the pressure, maintaining optimum clearance as dimensions change with temperature and pressure. A three way shuttle valve in the sideplate causes clamping pressure in port A or B, whichever is the highest.

Materials are chosen for long life efficiency. Vanes, rotor and cam ring are made out of hardened high alloy steels. Cast semi-steel sideplates are chemically etched to have a fine crystalline surface for good lubrication at start-up.

The cartridge is a replaceable assembly, including cam ring, rotor, vanes and springs.

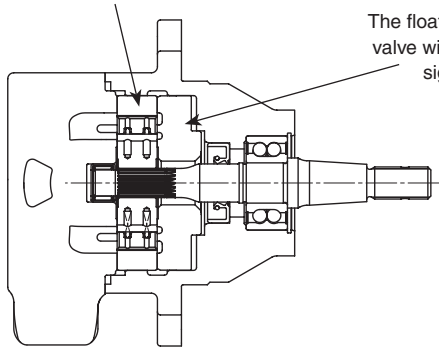

The floating side plate contains a shuttle valve which passes the highest pressure signal to the clamping area.

Cam ring is interchangeable with others of different displacements.

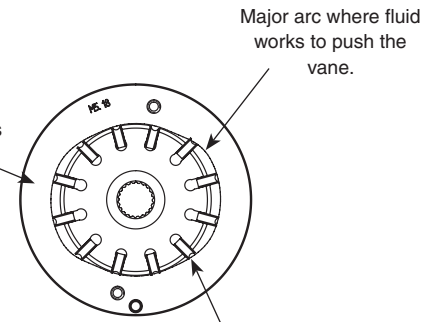

Major arc where fluid works to push the vane.

Side grooves and radial holes cause undervane and overvane pressure to be equal.

START UP & CHECK UP

Check that the assembly of the power unit is correct :

The distance between the suction pipe & the return lines in the tank should be at its maximum.

A bevel on both suction & return lines is recommended to increase the surface and so lower the velocity. We suggest a 45° minimum angle.

- M5 velocities : inlet $x < 6 \text{ m/s}$ ($x < 20 \text{ ft per sec.}$)
- : return under pressure $x < 6 \text{ m/s}$ ($x < 20 \text{ ft per sec.}$)
- : return low pressure $x < 3 \text{ m/s}$ ($x < 10 \text{ ft per sec.}$)
- : Always insure that all return and suction lines are under the oil level to avoid forming aeration or vortex effect. This should be done under the most critical situation (all cylinders extended for example).
Straight and short pipes are the best.

$$V = \frac{Q \text{ (l/min)}}{6 \times \pi \times r^2 \text{ (cm}^2\text{)}} = \text{m/s} \quad V = \frac{Q \text{ (GPM)}}{3.12 \times \pi \times r^2 \text{ (in}^2\text{)}} = \text{ft/s}$$

The size of the air filter should be 3 times greater than the max. instant return flow (ex: When all the cylinders are in movement).

A coaxial drive is recommended. For any other type of drives, please contact Parker.

Make sure that all protective plugs & covers have been removed.

PRIMING

The tank has been filled up with a clean fluid in proper conditions.

We recommend to flush the system with an external pump prior to the start-up.

It is important to bleed the air off the circuit and the motor itself. Manually, fill the motor housing with fluid, and connect the motor to the circuit.

Start rotation in a jogging manner until a prime is picked up, and increase the speed from 500 to 1000 rpm.

Check that there is no leakage or air suction neither at the ports (inlet, outlet, drain), nor at the shaft end.

If the motor does not prime properly in the first minute, or pressure can not be obtained, it should be shut down and condition corrected.

COLD STARTING

The motor should be started at low pressure and low speed until the fluid warms up, before running it at high pressure or speed.

The first valve on the circuit should be open to tank.

We recommend the use of air bleed off valves.

Warning : this has to be done in low pressure mode as it could create a dangerous fluid leak. Make sure that the pressure cannot rise (open center valve to tank, pressure relief valve unloaded ...).

When oil free of air appears, tighten the connectors to the correct torque.

The motor should prime within a few seconds. If not, please consult the troubleshooting guide (pages 32 & 33).

If the motor is noisy, please troubleshoot the system.

**1 . 2 . SHAFT & COUPLING DATA :
COUPLINGS AND FEMALE SPLINES**

- The mating female spline should be free to float and find its own center. If both members are rigidly supported, they must be aligned within 0,15 TIR (0.006" TIR) or less to reduce fretting. The angular alignment of two splines axes must be less than $\pm 0,05$ per 25,4 radius (± 0.002 " per 1" radius).

- The coupling spline must be lubricated with a lithium molydisulfide grease, disulfide of molybdenum or a similar lubricant.

- The coupling must be hardened to a hardness between 29 and 45 HRC.

- The female spline must be made to conform to the Class 1 fit as described in SAE-J498b (1971). This is described as a Flat Root Side Fit.

KEYED SHAFTS

Parker supplies the M5AS* series keyed shaft motors with high strength heat-treated keys. Therefore, when installing or replacing these motors, the heat-treated keys must be used in order to ensure maximum life in the application. If the key is replaced, it must be a heat-treated key between 27 and 34 R.C. hardness. The corners of the keys must be chamfered by 0,76 mm to 1,02 mm (0.03 to 0.04) at 45° to clear the radii in the key way.

The alignment of keyed shafts must be within tolerances given for splined shafts here above.

TAPERED KEY SHAFTS

The torque for a steel coupling and a nut, of at least grade 8.8 quality is 80 Nm (59 ft.lbs)

It is compulsory to install a castle nut + cotter pin when right hand rotation and bi-rotational.

SHAFT LOADS

The max. permissible load values are given in the sales catalogue.

**1.3. SPECIFIC POINTS :
VERTICAL MOUNT**

When assembled vertically, always be careful to prevent any air from being trapped in the motor housing.

MOTORS IN SERIES OR HIGH BACK PRESSURE

Please contact Parker.

PIPE

All fluid lines, either pipe, tubing or hose, must be of adequate size and strength to assure free flow to and from the motor. An undersized inlet line will restrict the fluid flow to the motor and prevent proper operation by creating turbulences and aeration.

If rigid pipe or tubing is used, the workmanship must be accurate in order to eliminate strain on the motor housing or the fluid connectors. Sharp bends in lines should be eliminated whenever possible.

All the system piping must be cleaned with solvent or an equivalent cleaning agent before being connected to the motor.

Do not use galvanized pipe. Galvanized coating may flake off after continued use.

THREADED PORTS

To be mounted in accordance with SAE J1926/2, ISO 6149/2 and ISO 1179.

EXTERNAL DRAIN

These externally drained motors must have a drain line connected to the center housing drain connection of sufficient size to prevent back pressure in excess of 3.5 bar (50 PSI), returning directly to the reservoir below the surface of the oil, and as far away as possible from the suction pipe of the pump.

It is preferable to install the center housing with the drain hole upward to facilitate the purge of the motor.

If the motor is mounted shaft up, the drain line must have a bend above the motor to purge it and to be sure that the shaft seal is lubricated (see drawing).

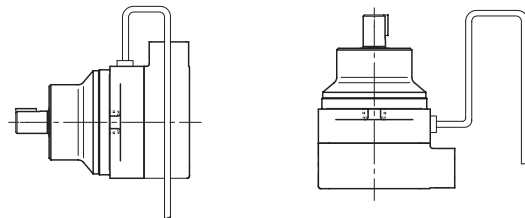

**MINIMUM REPLENISHMENT PRESSURE DURING
DECELERATION**

The hydraulic circuit should be designed in a way that when switching off the hydraulic motor, it remains supplied with fluid, without risk of cavitation (anti-cavitation valve may be needed).

Uni rotational M5AS* Motors are fitted with an internal anti-cavitation valve.

**Necessary pressure [bar absolute] at B port of
M5AS* uni-rotational during deceleration**

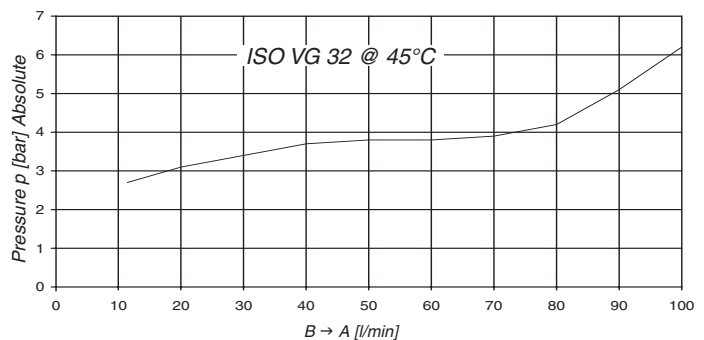

Uni-rotational M5AS - M5ASF option : Anti-starve check valve

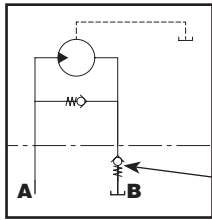

View from shaft end :

A = inlet

B = outlet

An anti-starve check valve can be screwed directly onto the B port of the uni-rotational motors, to ensure the minimum replenishment pressure during deceleration phases of high inertia systems (i.e. fan drive).

1.4. FLUIDS :

RECOMMENDED FLUIDS

Petroleum base anti-wear R & O fluids (covered by Parker Denison HF-0 and HF-2 specifications).

Maximum catalogue ratings and performance data are based on operation with these fluids.

ACCEPTABLE ALTERNATE FLUIDS

The use of fluids other than petroleum base anti-wear R & O fluids requires that the maximum ratings of the motor will be reduced. In some cases, the minimum replenishment pressure must be increased.

HF-1 : non antiwear petroleum base.

HF-4 : water glycols.

HF-5 : synthetic fluids.

Max. pressure : 210 bar (3000 PSI) (HF-1, HF-4, HF-5)

Max. speed : 1500 RPM (HF-4, HF-5)

VISCOSITY

Max. (cold start, low speed and pressure) 2000 mm²/s (cSt) (9400 SUS)

Max. (full speed and pressure) 100 mm²/s (cSt) (500 SUS)

Optimum (max. lifetime) 30 mm²/s (cSt) (140 SUS)

Min. (full speed and pressure, HF-1 fluid) 18 mm²/s (cSt) (90 SUS)

Min. (full speed and pressure, HF-0 & HF-2 fluids) 10 mm²/s (cSt) (60 SUS)

For cold starts, the motor should operate at low speed and pressure until fluid warms up to an acceptable viscosity for full power operation.

VISCOSITY INDEX

90 min.

Higher values extend the range of operating temperatures and lifetime.

TEMPERATURE

Max. fluid temperature (HF-0, HF-1 & HF-2) + 100° C (+212° F)

Min. fluid temperature (HF-0, HF-1 & HF-2) - 18° C (- 0.4° F)

FLUID CLEANLINESS

The fluid must be cleaned before and during operation to maintain a contamination level of NAS 1638 class 8 (or ISO 19/17/14) or better. Filters with 25 micron (or better, β10 ≥ 100) nominal ratings may be adequate but do not guarantee the required cleanliness levels.

WATER CONTAMINATION IN THE FLUID

Maximum acceptable content of water :

- 0,10 % for mineral base fluids.

- 0,05 % for synthetic fluids, crankcase oils, biodegradable fluids.

If the amount of water is higher, then it must be drained off the circuit.

1.5. SEALS :

SEALS S1 : NBR (NITRILE BASE POLYMER)

For standard applications: with mineral oil and fluid temperature less than + 90° C (+ 194° F).

S1 seal temperature range : - 40° C to + 107° C (- 40 to + 225° F).

SEALS S5 : FPM (FLUOROCARBON)

Use this seal type with fire resistant fluids and/or fluid temperature higher than + 90° C (+ 194° F).

S5 seal temperature range : - 29° C to + 204° C (-20 to + 400° F).

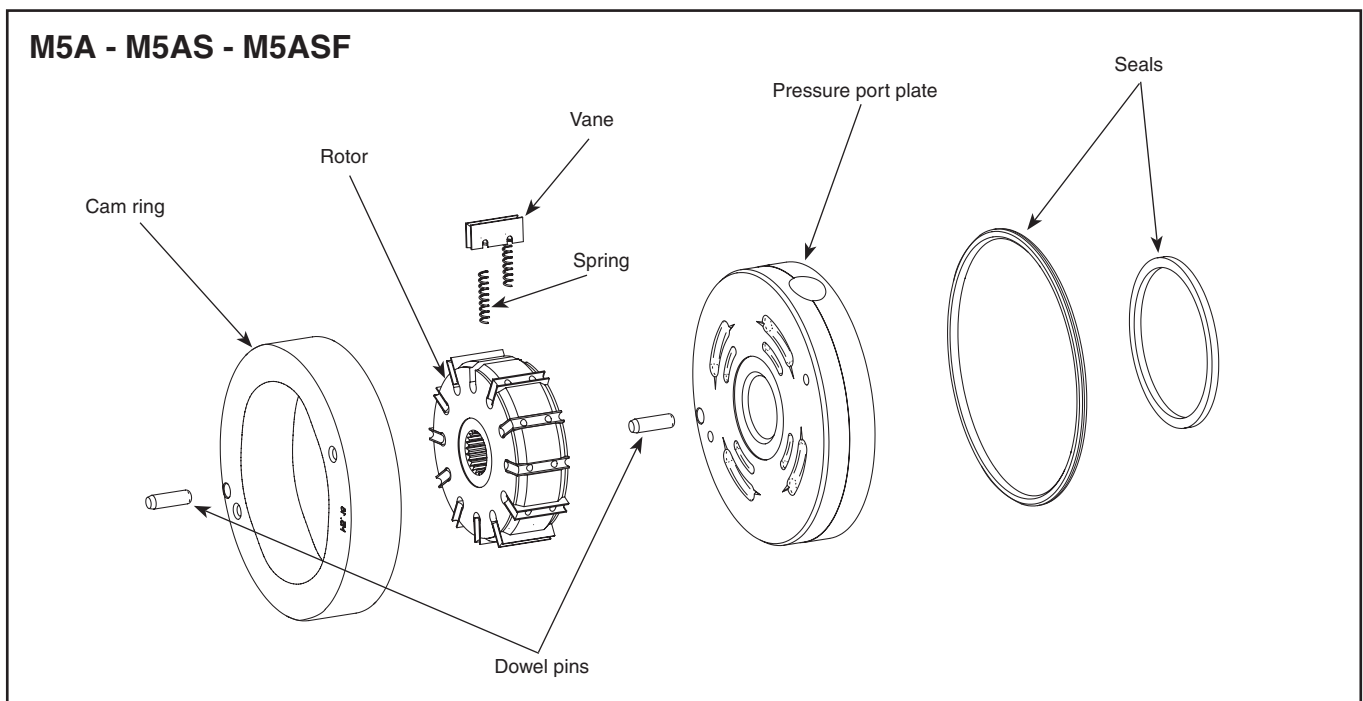
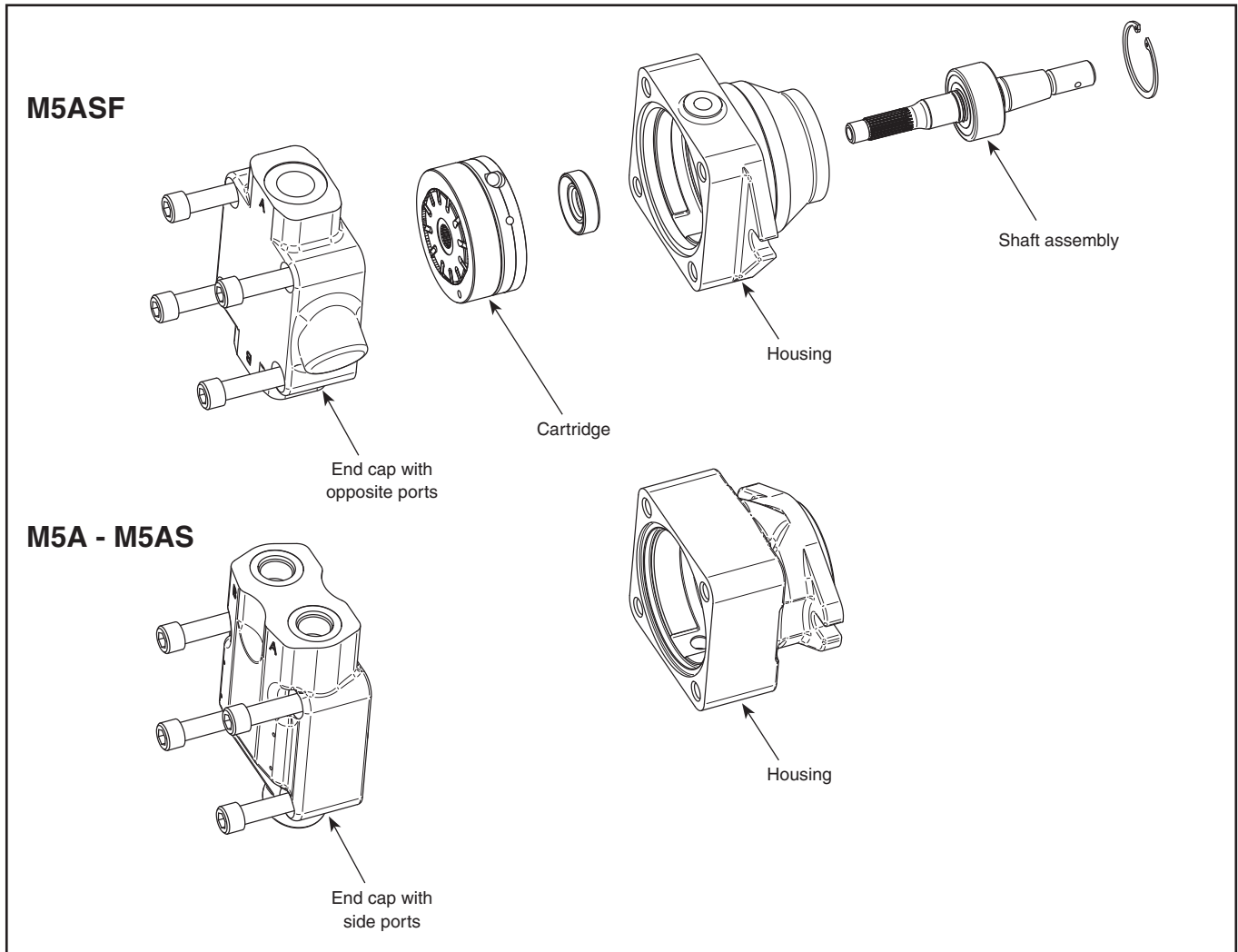

3.1. DISASSEMBLY / ASSEMBLY

3.1.a CHANGING CARTRIDGE :

1. Fix the motor on the table with 2 bolts.

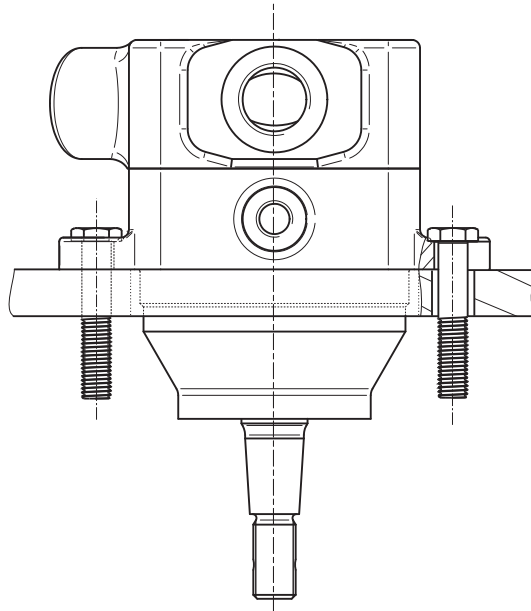

2. Remove the 4 screws.

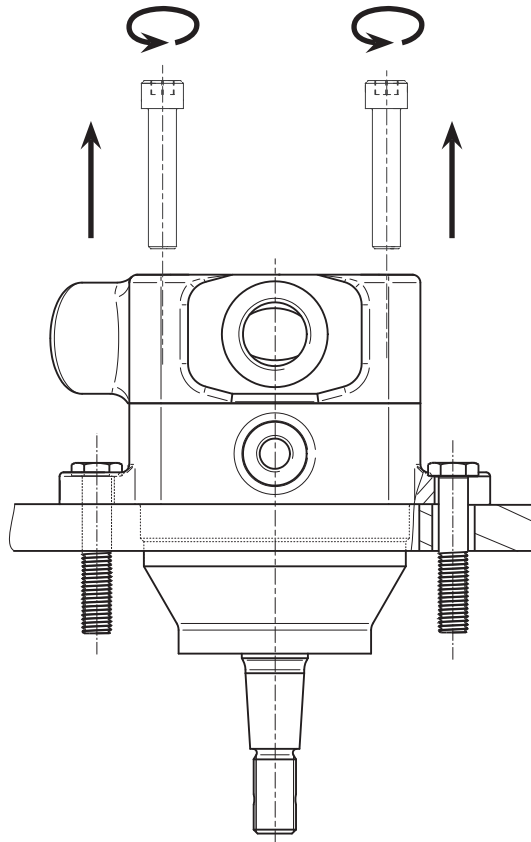

3.1. DISASSEMBLY / ASSEMBLY

3.1.a CHANGING CARTRIDGE :

3. Remove the end cap.

If exchanging the end cap only, check the seal and put back the new rear cap, go to page 19.

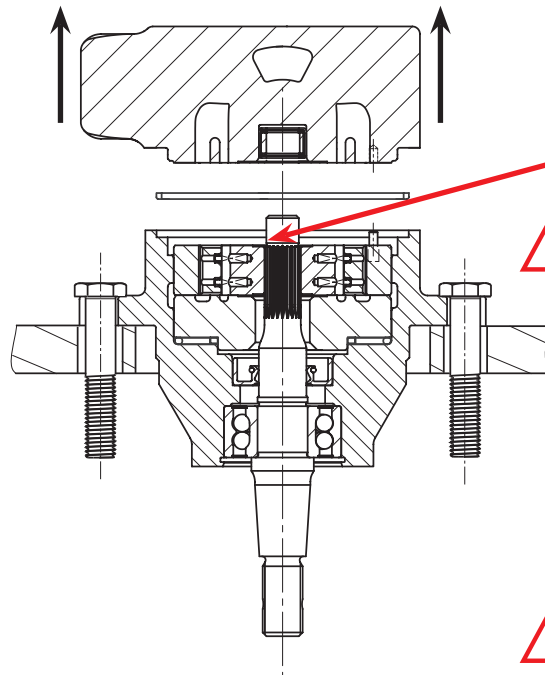

Be careful as some parts could "stick" to the end cap and come with it. Some parts could then fall (cartridge or pressure plate).



Check if the seal is correctly placed on the end cap. If not, put it back correctly.

4. Put two screws into the cam ring threaded holes.

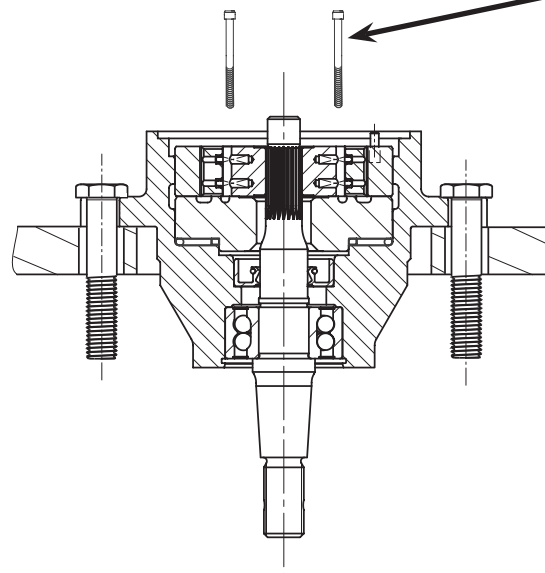

Use 2 screws
(10-24 UNC - Lg 3")
Ref.: 317-10320-0

3.1. DISASSEMBLY / ASSEMBLY

3.1.a CHANGING CARTRIDGE :

5 . Pull-up the two screws to take out the cartridge assembly.

If you want to change the shaft / shaft seal, then go to page 13.

If you want to reassemble a new cartridge, then go to page 16.

If you want to disassemble the cartridge, go to the next page.

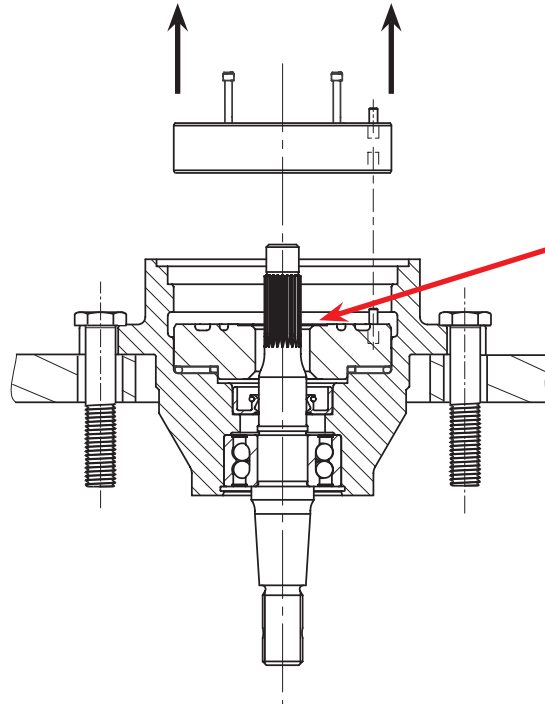

Carefully lift the cam ring and rotor assembly making sure that the rotor is coming out with all the vanes staying in their slots. Also beware that the pressure plate could stick to the cam ring and then fall down.

Conversions

3.1. DISASSEMBLY / ASSEMBLY

3.1.b CHANGING DISPLACEMENT :

6. Cam ring change.

-  **Two procedures :**
 1) displacement > previous
 2) displacement < previous

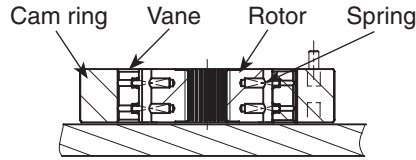

The new cam ring is of a bigger displacement than the actual one.

The new cam ring is of a smaller displacement than the actual one.

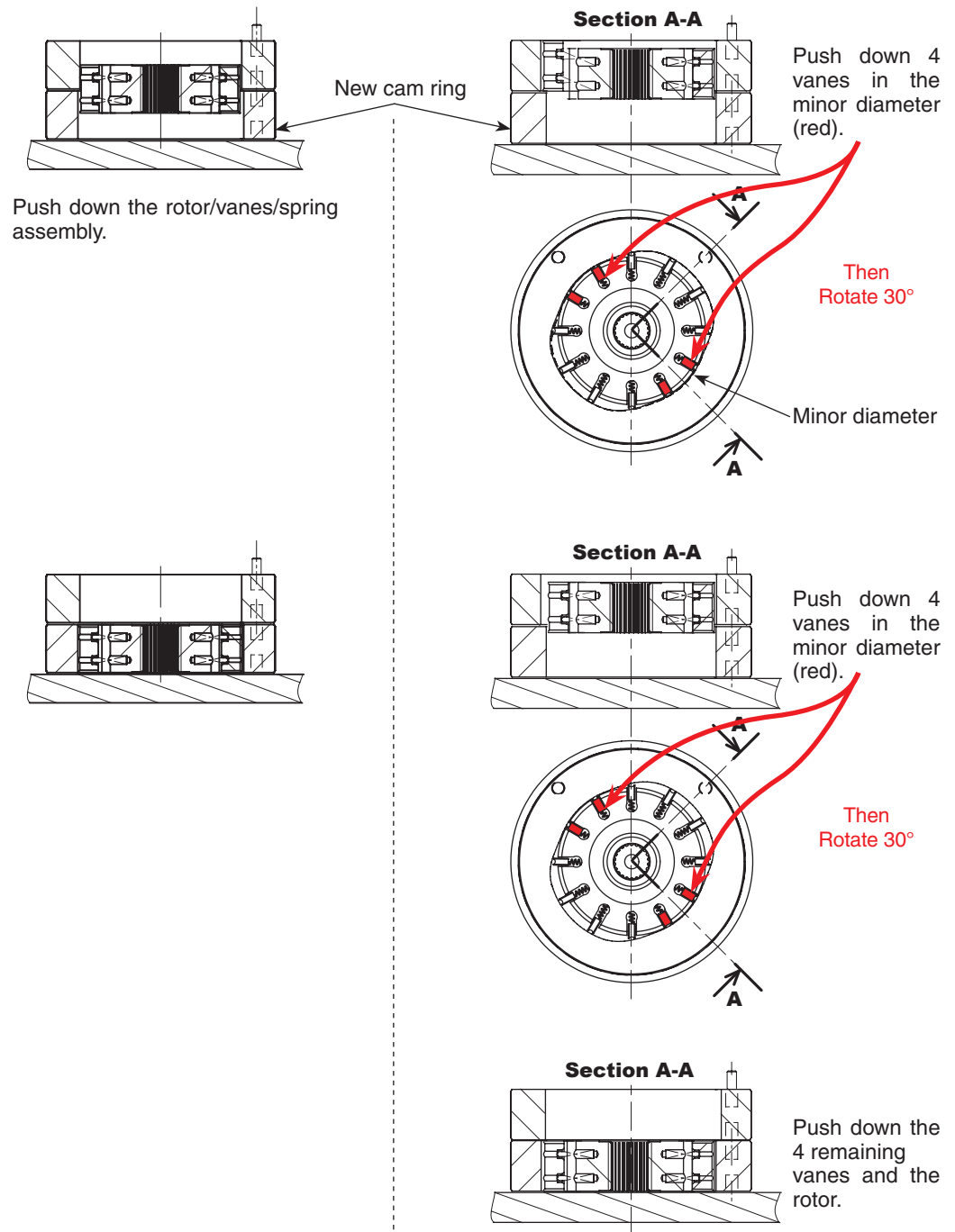

If you want to assemble the cartridge in the motor, go to page 16.

3.1. DISASSEMBLY / ASSEMBLY

3.1.c CHANGING SHAFT :

7. Screw on two screws in the floating port plate threaded holes.

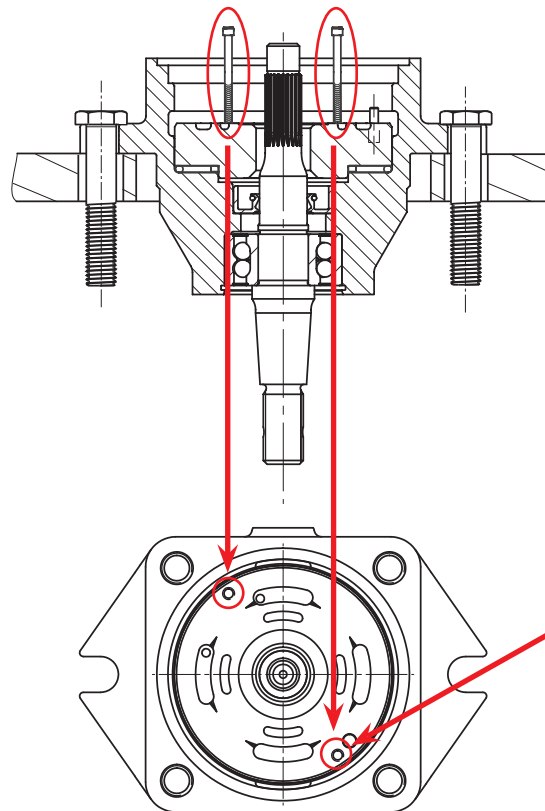

Threaded holes designed to pull out the port plate
Use 2 screws
(10-24 UNC - Lg 3")
Ref.: 317-10320-0

8. Pull out the floating port plate.

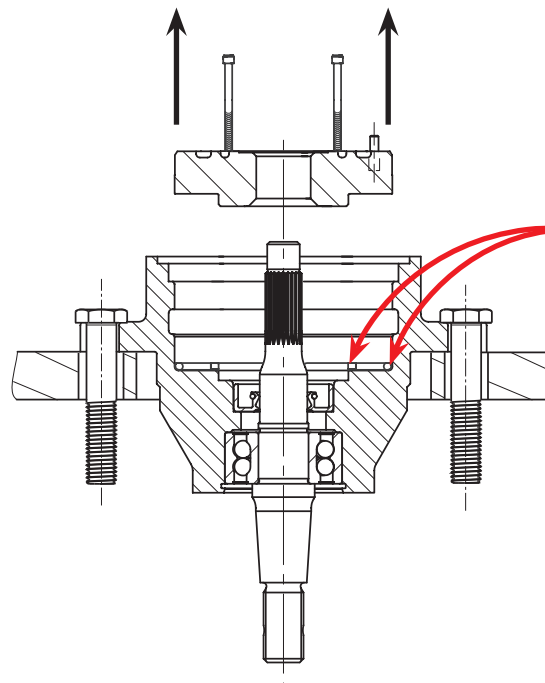

Lift the two screws at the same time to avoid the floating port plate to block itself in the housing.



Be careful as the seals could stick to the port plate and then fall down.

3.1. DISASSEMBLY / ASSEMBLY

3.1.c CHANGING SHAFT :

9 . Disassemble the shaft & bearing assembly.

A : Remove the retaining ring.

B : Pull-out the shaft & bearing assembly.

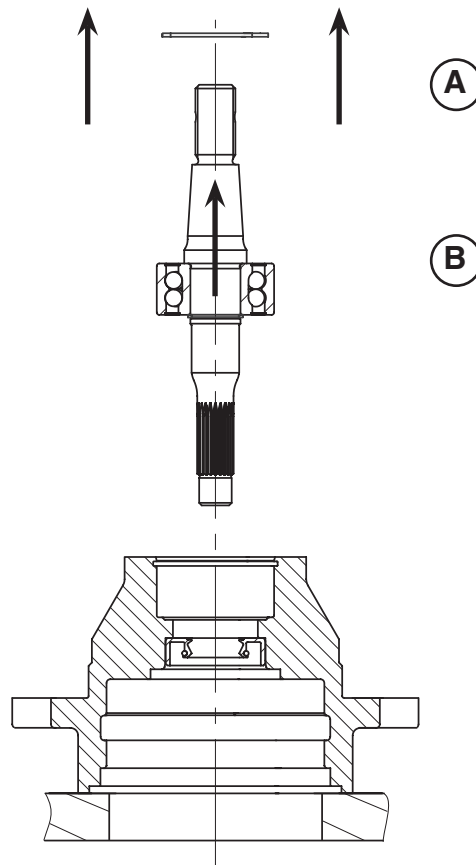

10 . Take the shaft seal out.

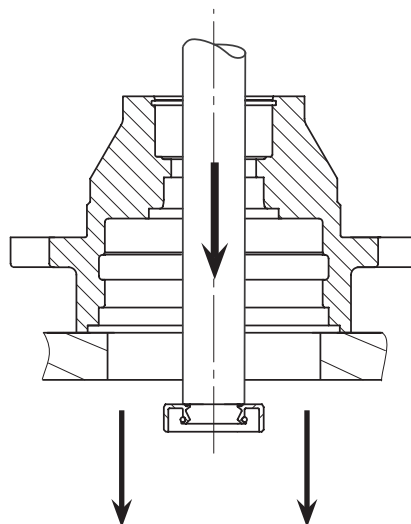

Always replace the shaft seal. (Disassembly is destructive.)

Shoulder Bar dimensions:
 Bar : Max. Ø 30,0 mm
 Shoulder : Ø 19,0 mm

3.1. DISASSEMBLY / ASSEMBLY

3.1.d ASSEMBLY :

11. Install the new shaft seal using the seal driver tool (see page 31).

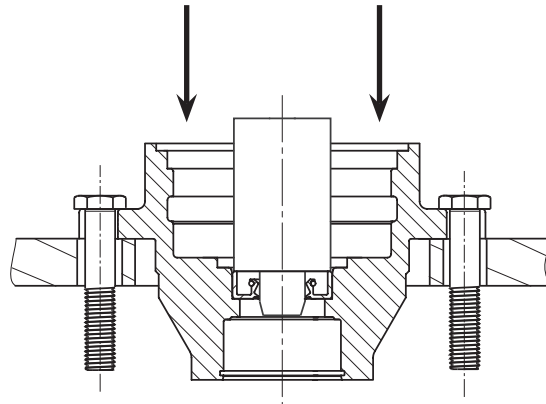

Press carefully to avoid damaging the seal. Don't use a hammer.

12. Shaft assembling.

A : Assemble the bearing on the shaft (push on the inner bearing cage).

B : Place the shaft & bearing assembly in the housing (loose fit).

C : Insert the retaining ring into the housing.

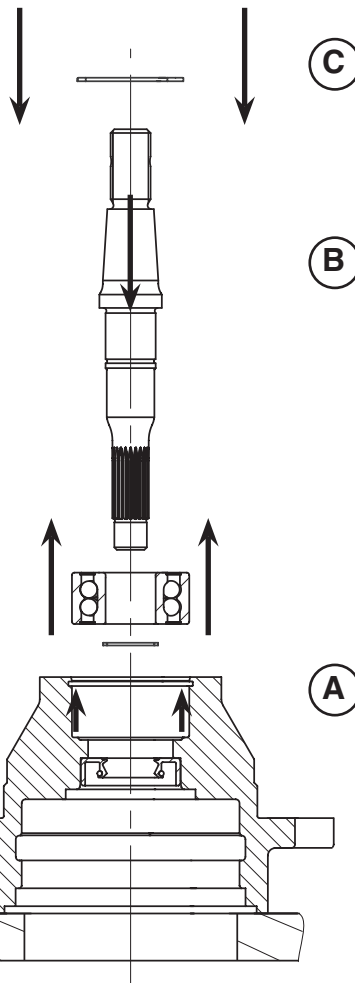

Gently push the shaft & bearing assembly as to avoid the destruction of the shaft seal.



Conversions

3.1. DISASSEMBLY / ASSEMBLY

3.1.d ASSEMBLY :

13 . Floating port plate assembly .

A : Place seal # 1 on the port plate (use some grease to «stick» it).

B : Insert seal # 2 inside the housing.

C : Slide the floating port plate in the housing.

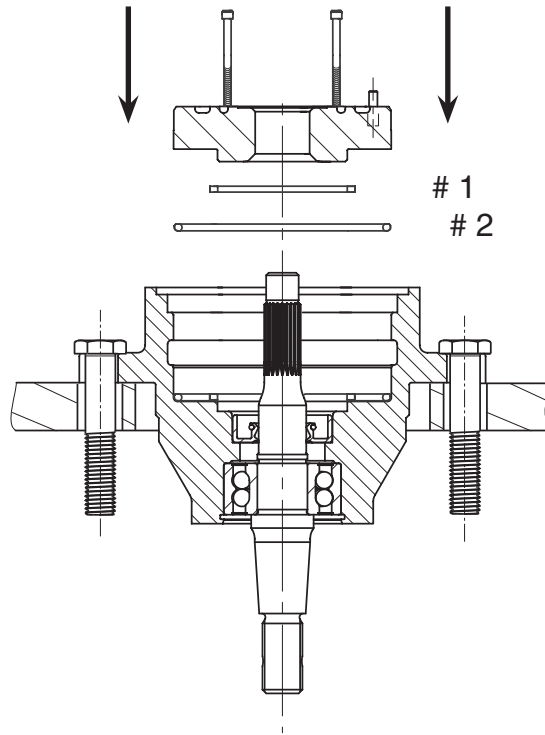

Make sure to maintain the floating port plate horizontal to avoid blocking it inside the housing.

14 . Position the dowel pin in the floating port plate according to the desired rotation way.

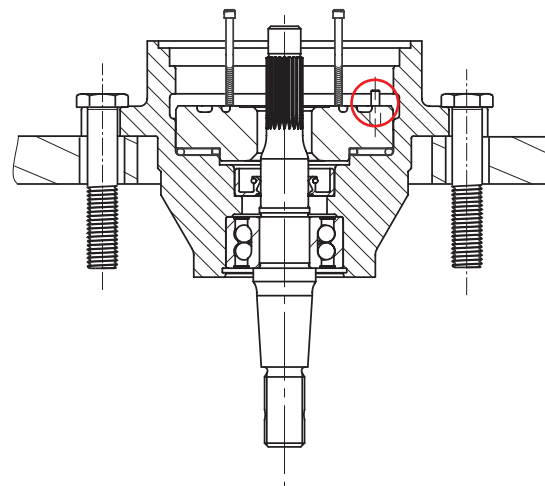

3.1. DISASSEMBLY / ASSEMBLY

3.1.d ASSEMBLY :

15. Position the cartridge in the housing.

Check if the shaft rotates!

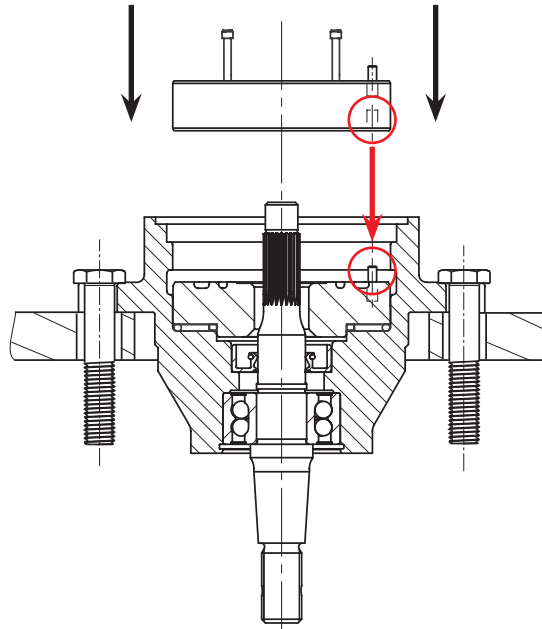

16. Position the floating port plate according to the requested rotation way.

M5AS - M5ASF - Right or bi-rotational rotation

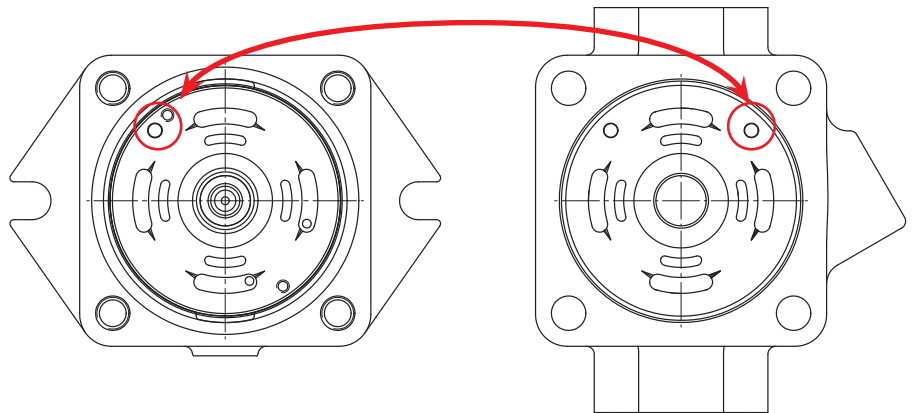

M5AS - M5ASF - Left rotation

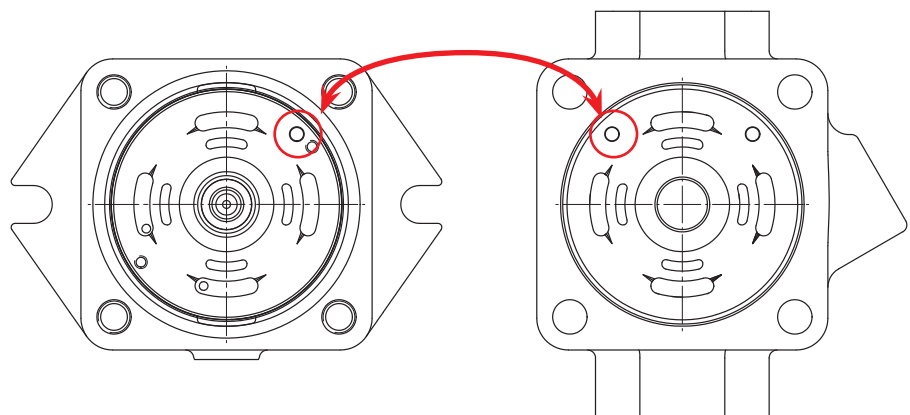

3.1. DISASSEMBLY / ASSEMBLY

3.1.d ASSEMBLY :

Place the quad seal on to the end cap. (use some grease to make sure the seal stays in its position).

17. Position the end cap.

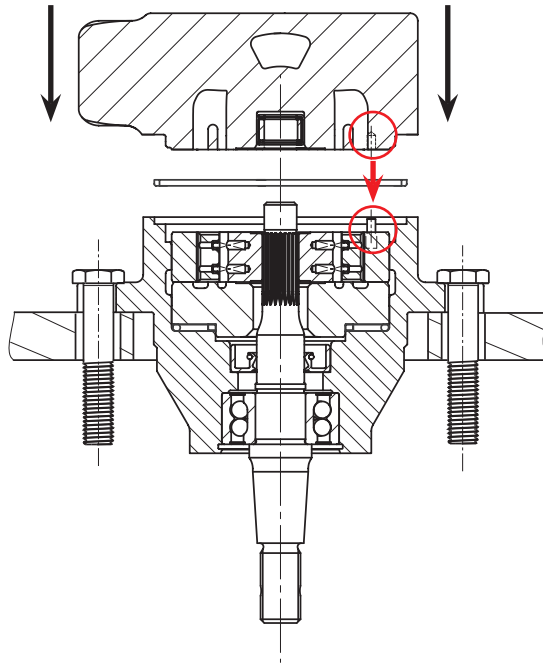

Check that the seal remains correctly placed on the end cap.



Be careful with the dowel pin positioning.

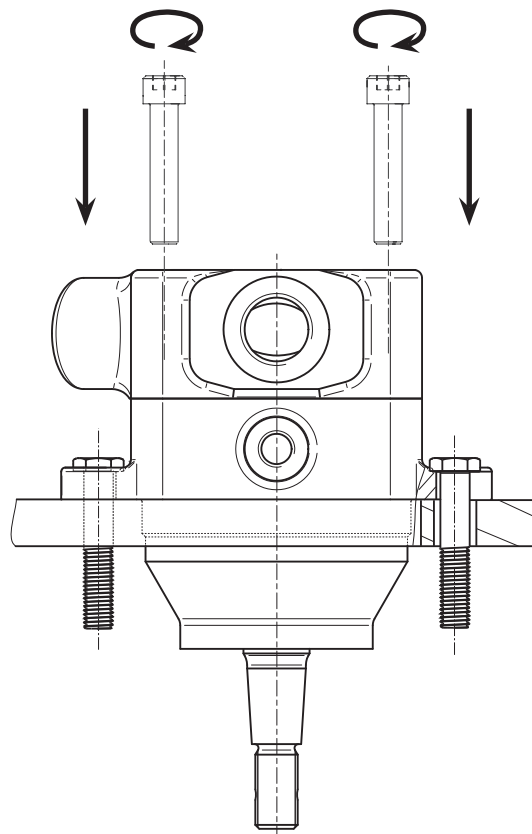

a) Always check if the shaft rotates. If not, disassemble and go back to the previous step.

b) Check the porting configuration (see table page 30).

c) Tighten the 4 screws step by step to avoid damaging the seals.

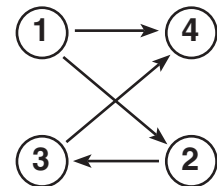

d) Always check if the shaft rotates. If not, disassemble and go back to the previous step.

TIGHTENING TORQUE :

100 Nm	73.8 Ft.lbs
--------	-------------

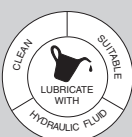

3 . 2 . CHANGING ROTATION :

1 . Fix the motor on the table with 2 bolts.

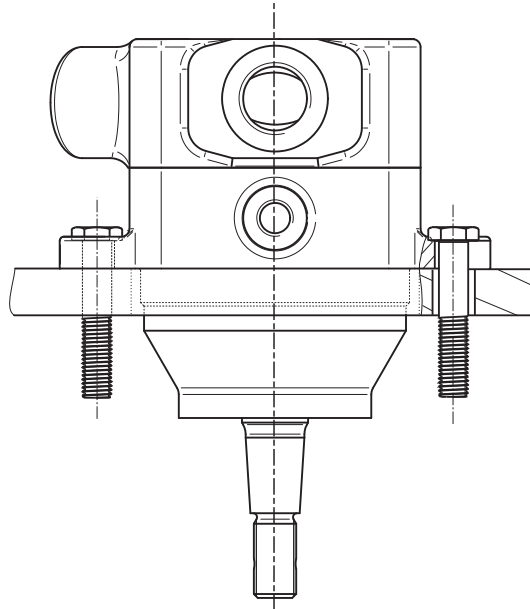

2 . Remove the 4 screws.

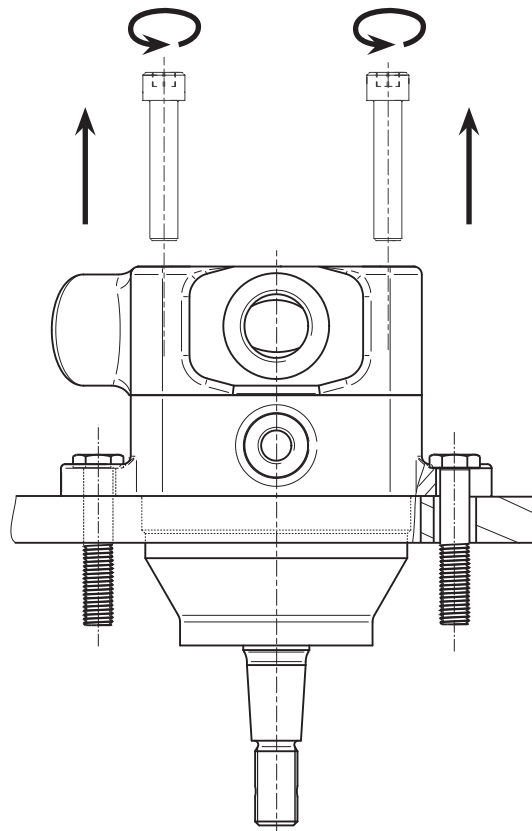

3.2. CHANGING ROTATION :

3. Remove the end cap.



Only right or left rotation motors are concerned.

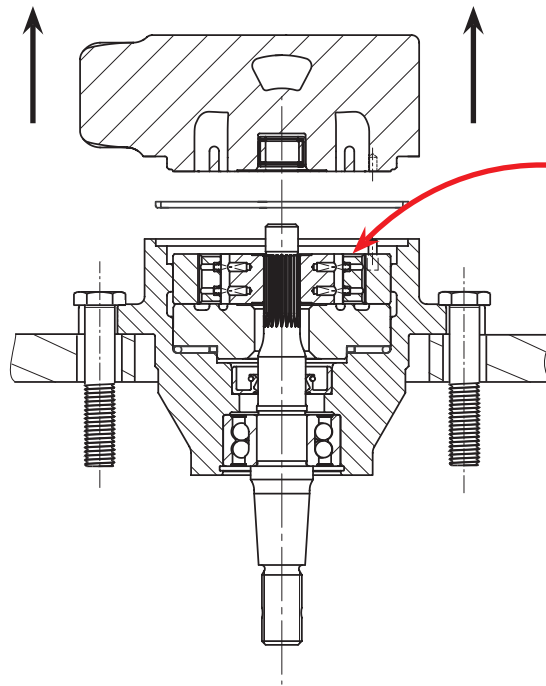

Be careful as some parts could "stick" to the end cap and then fall down (cartridge or pressure plate).

3.2. CHANGING ROTATION :

End cap with opposite ports

4 . Position the dowel pin according to the desired rotation way.

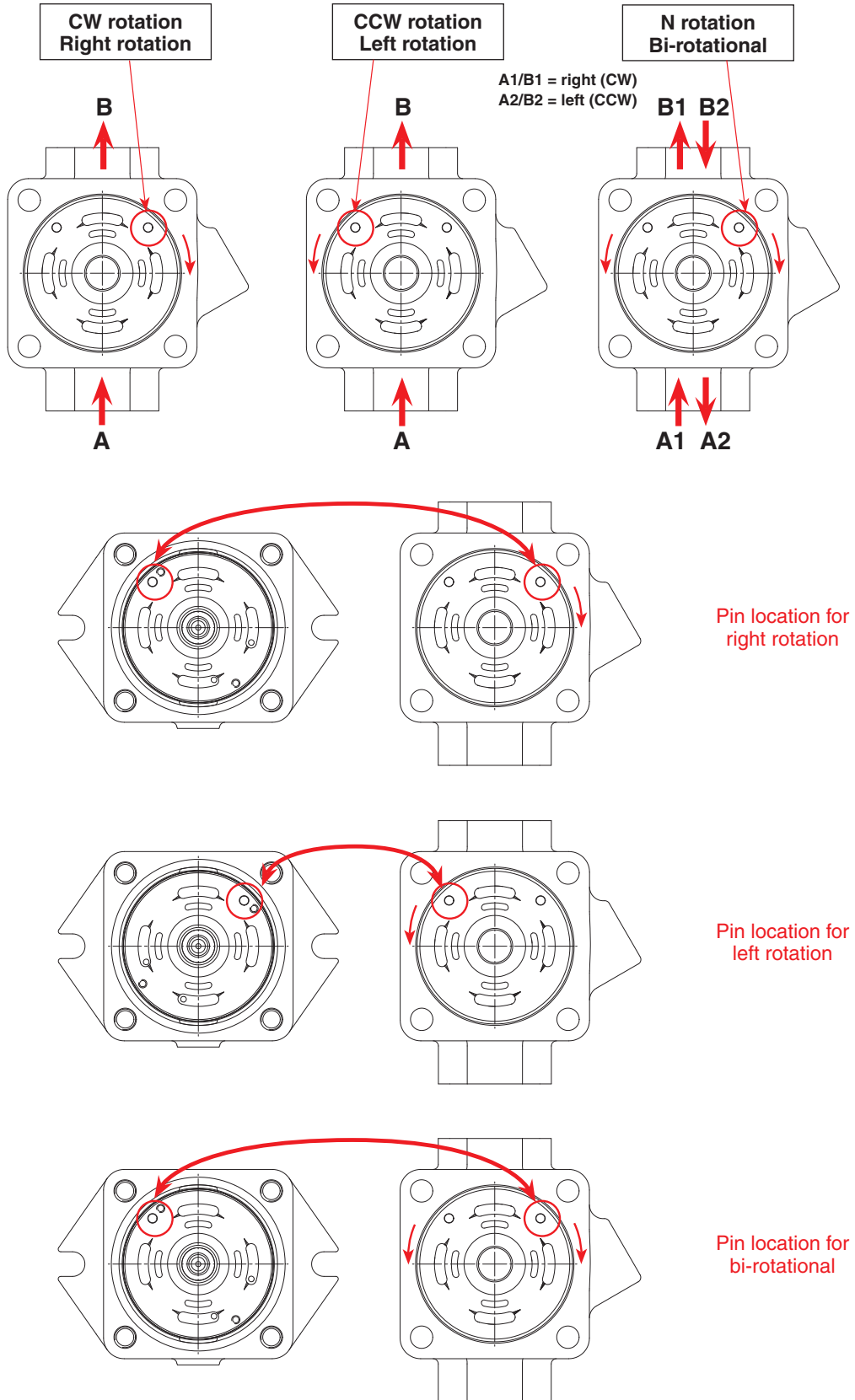

3.2 . CHANGING ROTATION :

End cap with side ports

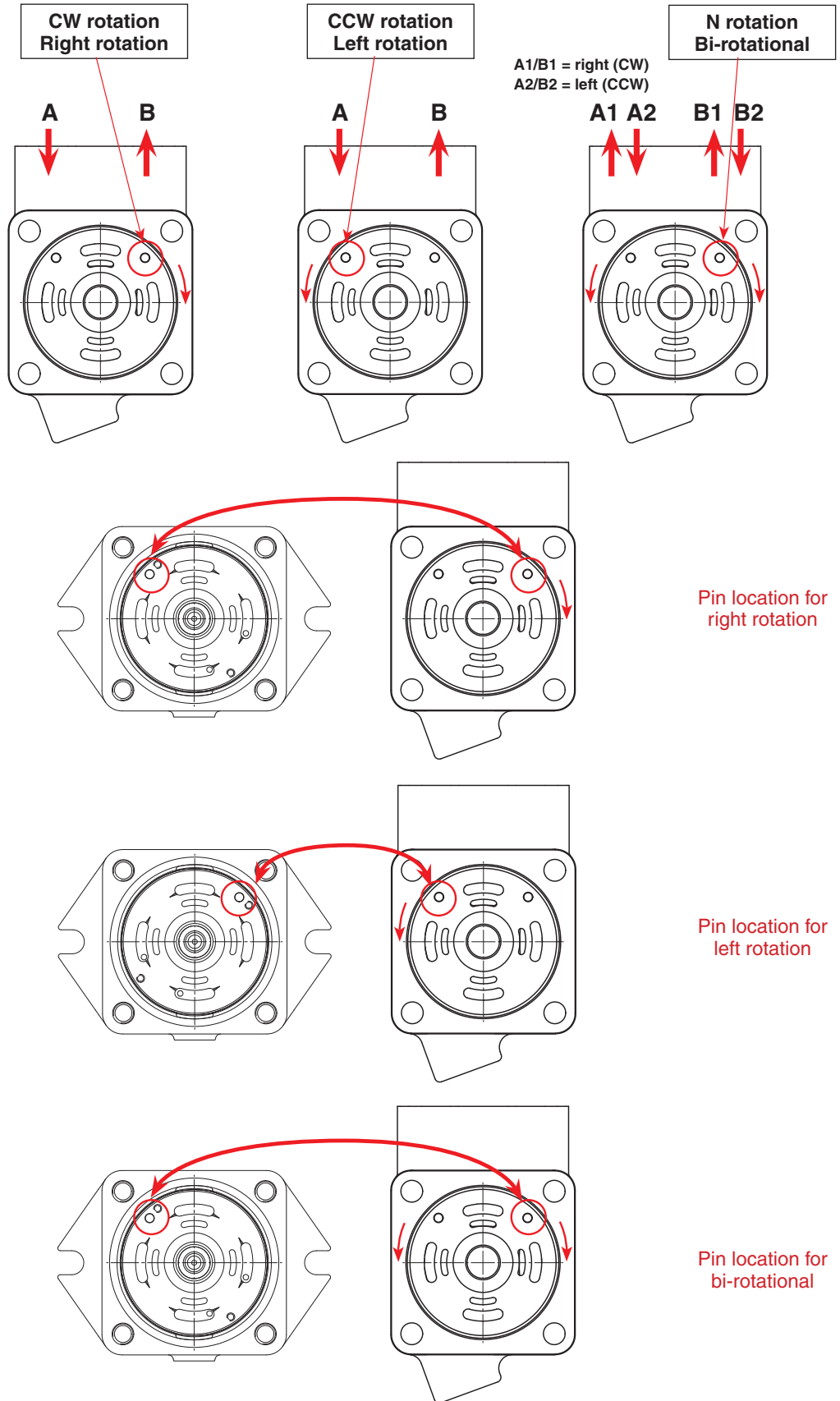

3.2. CHANGING ROTATION :

Place the quad seal on to the end cap. (use some grease to make sure the seal stays in its position).

5. Position the end cap.

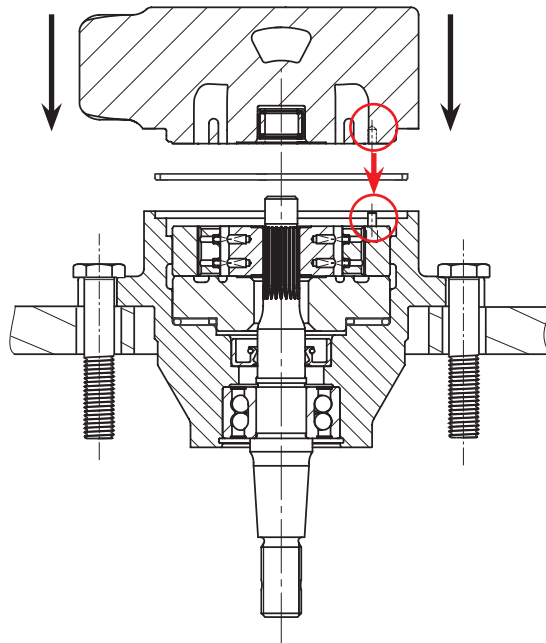

Check that the seal remains correctly placed on the end cap.



Be careful with the dowel pin positioning.

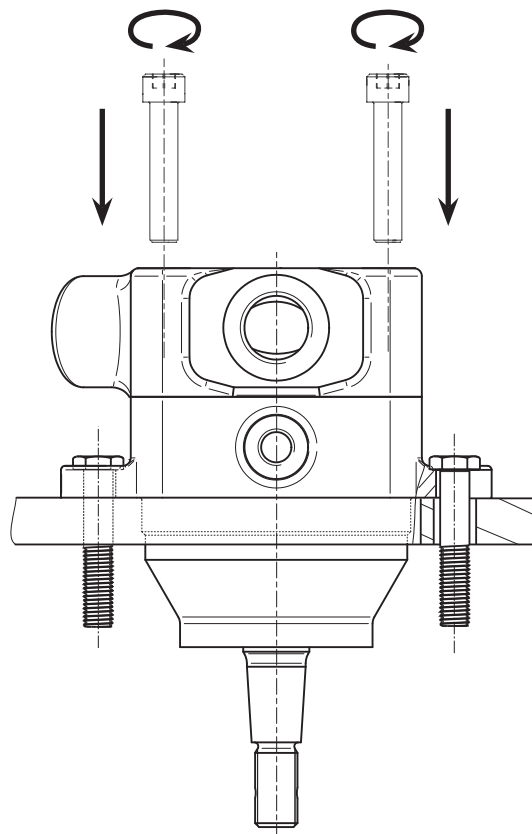

a) Always check if the shaft rotates. If not, disassemble and go back to the previous step.

b) Check the porting configuration (see table page 30).

c) Tighten the 4 screws step by step to avoid damaging the seals.

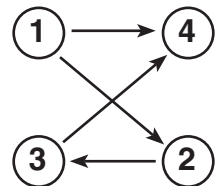

d) Always check if the shaft rotates. If not, disassemble and go back to the previous step.

TIGHTENING TORQUE:

100 Nm	73.8 Ft.lbs
--------	-------------



3.3 . CHANGING PORTING ORIENTATION :

1 . Fix the motor on the table with 2 bolts.

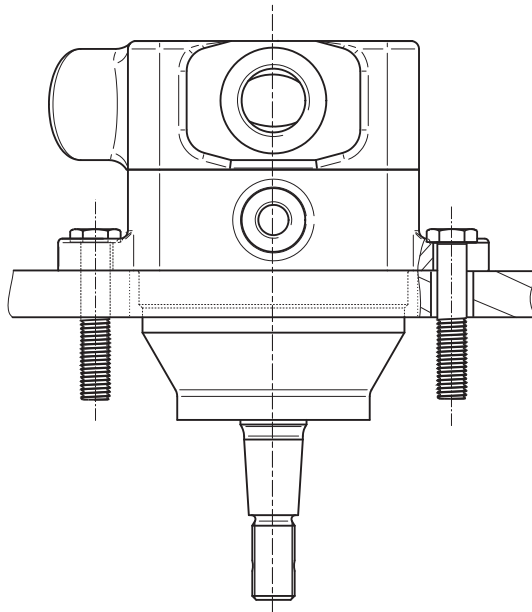

2 . Remove the 4 screws.

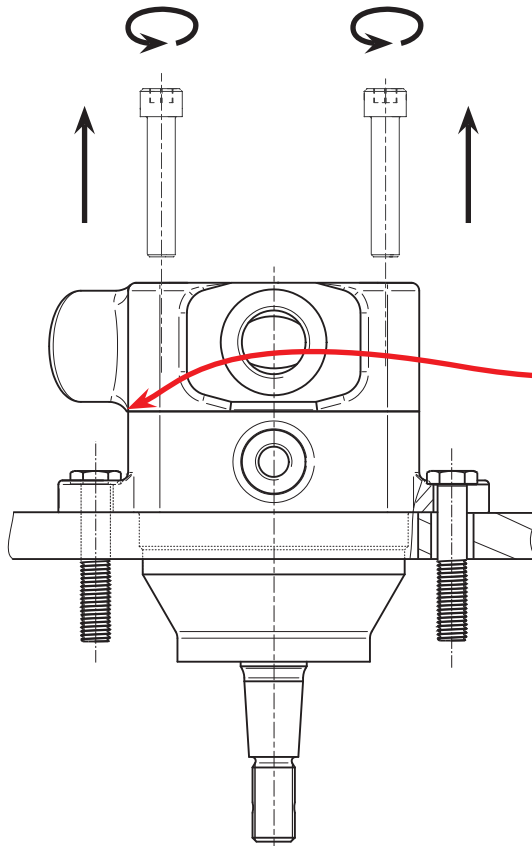

Do not lift the end cap to prevent the dowel pin inside the motor from leaving its location.

3.3. CHANGING PORTING ORIENTATION :

3 . Place two screws in the end cap as shown.

4 . Lift the two screws high enough or use longer screws...

5 . Rotate the end cap with a bar blocked between the two screws.

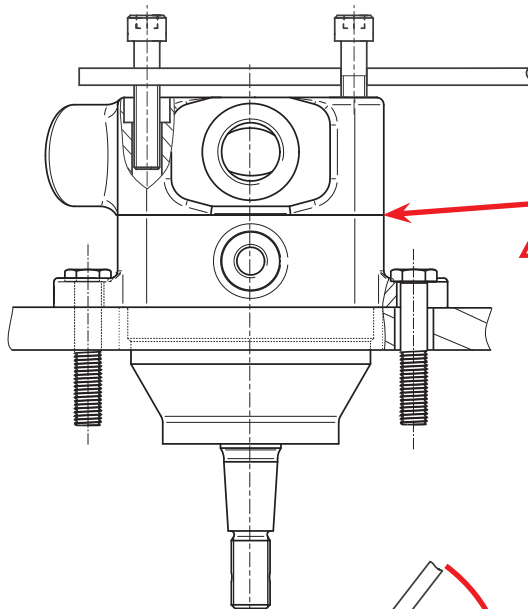
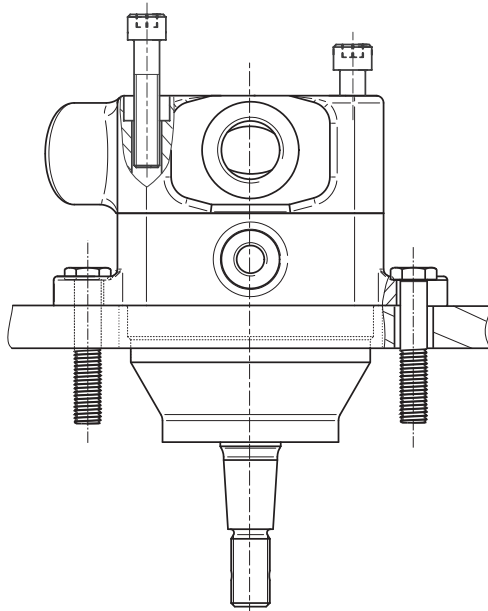

Do not lift the end cap, to prevent the dowel pin inside the motor from leaving its location.

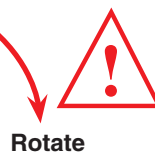
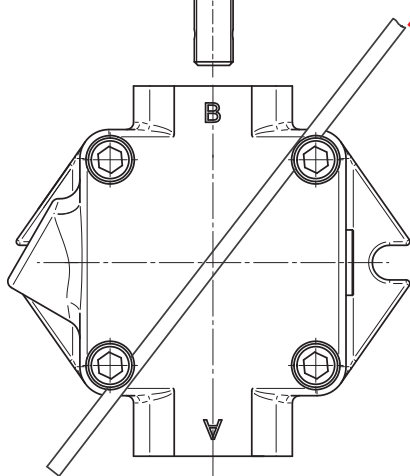

Always rotate in the same direction.

CW



3.3. CHANGING PORTING ORIENTATION :

6. Put back the 4 screws.

7. Tighten to the correct torque
(see table hereunder).

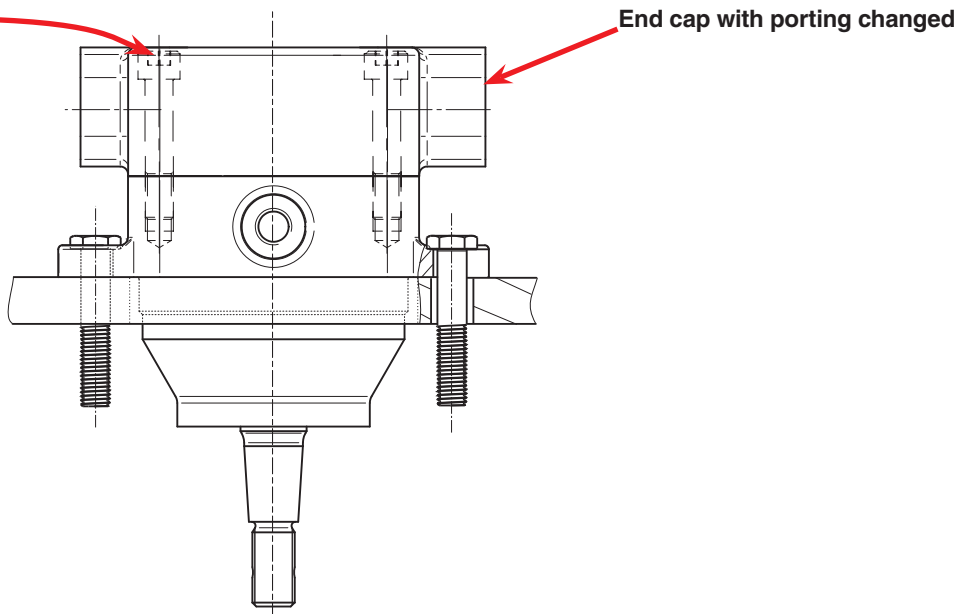

a) Always check if the shaft rotates. (a slight resistance due to the spring loaded vanes is normal). Otherwise, please go back to the previous step.

b) Check the porting configuration (see table page 30).

c) Tighten the 4 screws step by step to avoid damaging the seals.

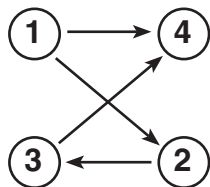

d) Always check if the shaft rotates.
If not, disassemble and go back to the previous step.

TIGHTENING TORQUE :

100 Nm	73.8 Ft.lbs
--------	-------------

3.4. VALVES :

Anti-cavitation check valve :

This valve is included in the uni-rotational motor only.

The check valve assembly is not a serviceable part and must be replaced in case of failure.

End cap with opposite ports

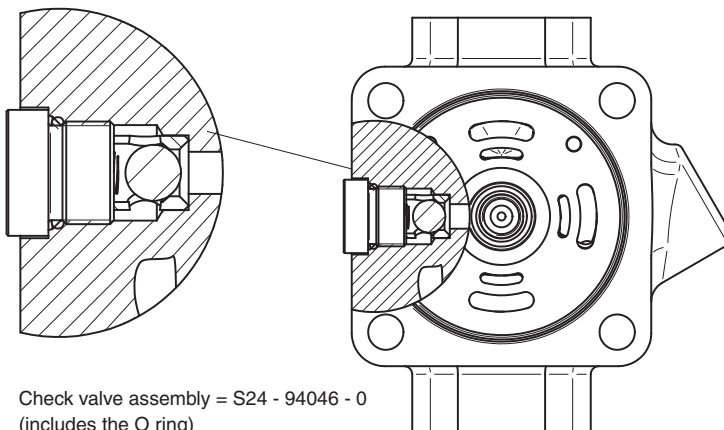

Check valve assembly = S24 - 94046 - 0
 (includes the O ring)

End cap with side ports

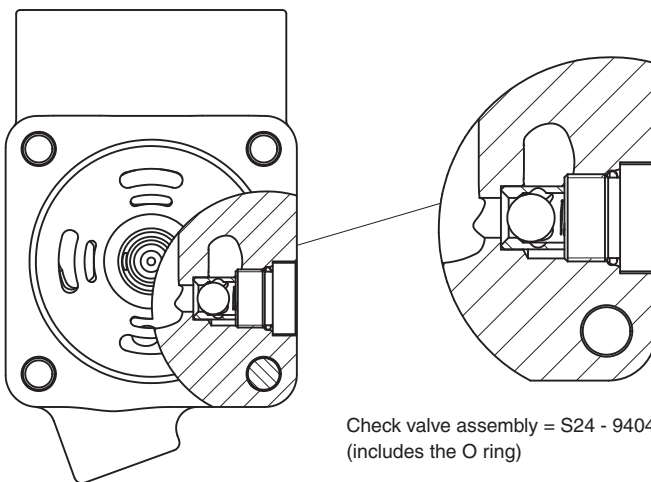

Check valve assembly = S24 - 94046 - 0
 (includes the O ring)

TIGHTENING TORQUE :

50 Nm	36.8 Ft.lbs
-------	-------------

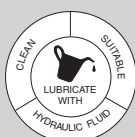

3.4. VALVES :

Pressure relief valves :

Pressure relief valves are factory set and setting value should not be changed.

The pressure relief valve is not a serviceable part and must be replaced in case of failure.

End cap with opposite ports

Proportional pressure relief valve

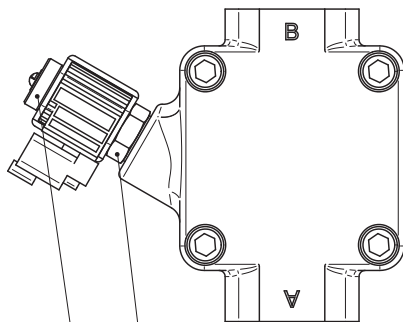

Mounting torque : 34 N.m
 Mounting torque : 4,1 N.m max

Standard pressure relief valve

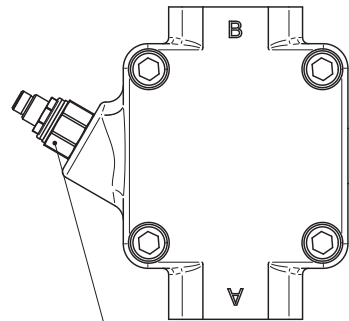

Mounting torque : 22 N.m

End cap with side ports

Proportional pressure relief valve

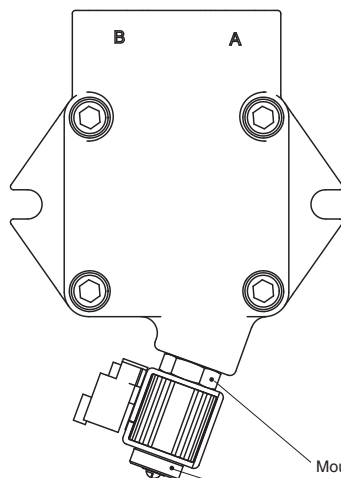

Mounting torque : 34 N.m
 Mounting torque : 4,1 N.m max

Standard pressure relief valve

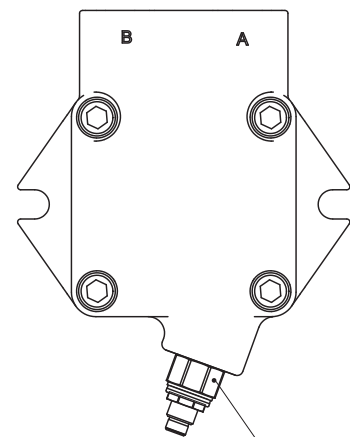

Mounting torque : 22 N.m

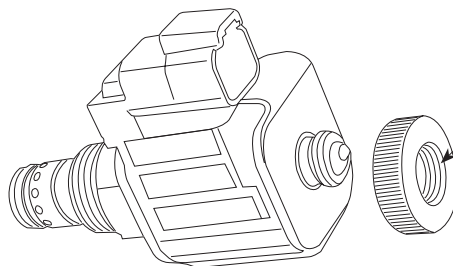

The coil's locking nut is having internal threads on one side only.
 The threaded side must be located at solenoid's end.
 The coil should not be free to rotate.



Do not exceed 4,1 Nm



Key sheet

**Overall Hydraulic Motors, Fixed
M5AS - M5ASF Denison Vane Motors**

4.1. KEY SHEET

Model No. M5AS - 018 - 1 N 02 - A 1 W - P21

M5A series - ISO 3019-2
Mounting flange 80 A2 SW
M5AS series - SAE A 2-bolts
J744 mounting flange

Cam ring
Volumetric displacement (ml/rev)
006 = 6,3 018 = 18,0
010 = 10,0 023 = 23,0
012 = 12,5 025 = 25,0
016 = 16,0

Type of shaft M5AS
1 = Taper (SAE B)
2 = Keyed (SAE B)
Type of shaft M5A or M5AS
5 = Taper 1/5
6 = Keyed (ISO G20N)

Direction of rotation (shaft end view)
R = Clockwise (with anti-cavitation check valve)
L = Counter-clockwise (with anti-cavitation check valve)
N = Bi-rotational (without anti-cavitation check Valve)

End cap type
0 = with opposite ports
1 = with side ports

Porting combination
(See table page 30)

Modifications or special option

Ex. : P21 = Proportional pressure relief valve set at 210 bar at 1000 rpm

End cap variables

M5A bi-rotational series		
Code	A & B ports	Drain port
Y	Metric thread M22 x 1,5	Metric thread M12 x 1,5

M5A uni-rotational series			
Code	A port	B port	Drain port
Y	Metric thread M22 x 1,5	Metric thread M27 x 2	Metric thread M12 x 1,5

M5AS bi-rotational series		
Code	A & B ports	Drain Port
W	SAE 12 thread 1.1/16"-12 UNF	SAE 6 thread 9/16"-18 UNF
Z	3/4" BSPP	1/4" BSPP

M5AS uni-rotational series			
Code	A port	B port	Drain port
W	SAE 10 thread 7/8"-14 UNF	SAE 12 thread 1.1/16"-12 UNF	SAE 6 thread 9/16"-18 UNF
Z	1/2" BSPP	3/4" BSPP	1/4" BSPP

Seal class

1 = S1 BUNA N
5 = S5 - VITON®

Design letter

Model No. M5ASF - 018 - 1 N 02 - A 1 W - P21

M5ASF - 2-bolts flange
Ø 101,6 h8

Cam ring
Volumetric displacement (ml/rev)
006 = 6,3 018 = 18,0
010 = 10,0 023 = 23,0
012 = 12,5 025 = 25,0
016 = 16,0

Type of shaft
1 = Taper (SAE B)
2 = Keyed (SAE B)
5 = Taper 1/5
6 = Keyed (ISO G20N)

Direction of rotation (shaft end view)
R = Clockwise (with anti-cavitation check valve)
L = Counter-clockwise (with anti-cavitation check valve)
N = Bi-rotational (without anti-cavitation check Valve)

End cap type
0 = with opposite ports
1 = with side ports

Porting combination
(See table page 30)

Modifications or special option

Ex. : P21 = Proportional pressure relief valve set at 210 bar at 1000 rpm

End cap variables

M5ASF bi-rotational series		
Code	A & B ports	Drain port
Y	Metric thread M22 x 1,5	Metric thread M12 x 1,5
W	SAE 12 thread 1.1/16"-12 UNF	SAE 6 thread 9/16"-18 UNF
Z	3/4" BSPP	1/4" BSPP

M5ASF uni-rotational series			
Code	A port	B port	Drain port
Y	Metric thread M22 x 1,5	Metric thread M27 x 2	Metric thread M12 x 1,5
W	SAE 10 thread 7/8"-14 UNF	SAE 12 thread 1.1/16"-12 UNF	SAE 6 thread 9/16"-18 UNF
Z	1/2" BSPP	3/4" BSPP	1/4" BSPP

Seal class

1 = S1 BUNA N
5 = S5 - VITON®

Design letter

4.2. PORTING TABLES :

Motor with opposite ports

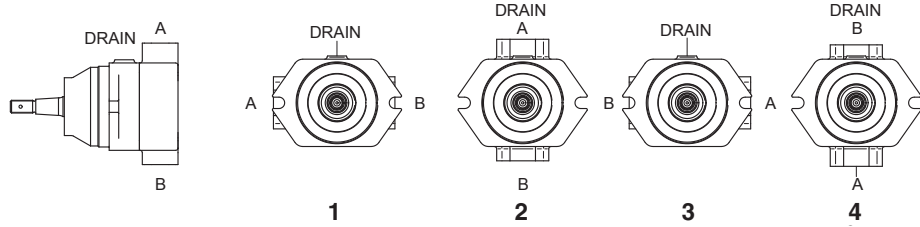

Motor with side ports

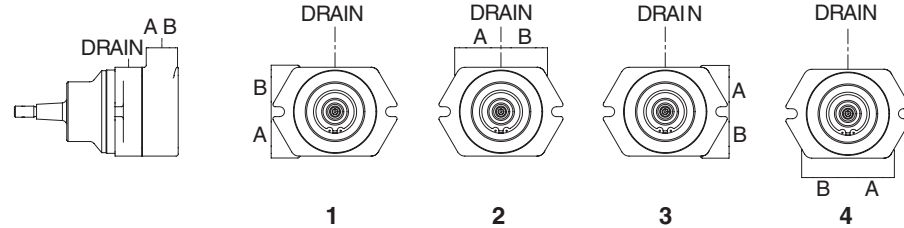

ROTATION :

BI-ROTATIONAL (N)

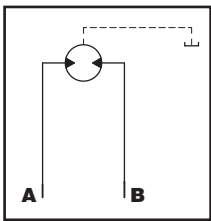

View from shaft end :

- CW rotation A = inlet
 B = outlet
- CCW rotation A = outlet
 B = inlet

R or L ROTATION (New rotation concept - patent pending)*

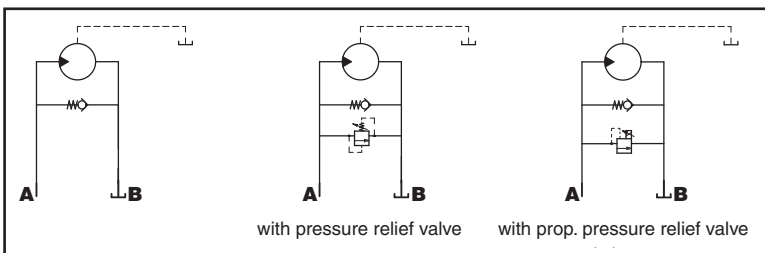

View from shaft end :

- CW or CCW rotations A = inlet
 B = outlet



* R or L rotation are featuring a new internal concept where A is always “in” and B is always “out”.

4.3. TIGHTENING TORQUE :

100 Nm	73.8 Ft.lbs
--------	-------------

5.1. SEAL DRIVER - DIMENSIONS :

Series	Tool N°	Ø A		Ø B		C	
		mm	inch	mm	inch	mm	inch
M5AS - M5ASF	DM3-418S1-5	18,92 19,05	0.745 0.750	39,82 39,98	1.568 1.574	90	3.543

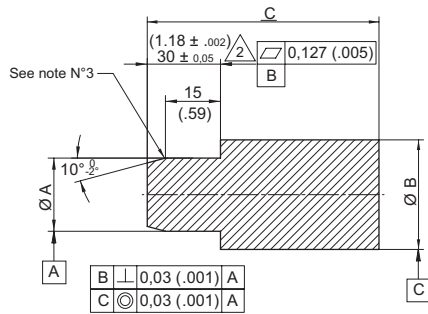

NOTES :

1. Remove all burrs and break sharp edges: 0.25/0.13 R (.010/.005 R).
2. Length \triangle to be heat treated to 47 + 3 HRC.
3. Length \triangle to have a $\sqrt{10-20}$ full length, with a smooth intersection between chamfer and dia. "A".
4. Grease O.D. of length \triangle before installing the shaft seal on the tool to avoid damaging the seal. Material US 4140 / UK 708M40 or equivalent.

6.1. FEMALE COUPLING DIMENSIONS :

CYLINDRICAL KEYED SHAFTS :

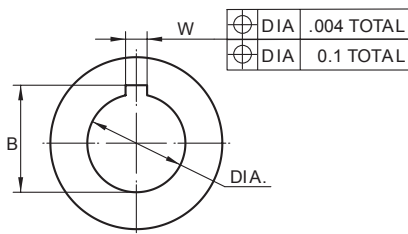

Shaft	M5AS - M5ASF	
	Code 2	Code 6
DIA	22,23/22,25 (.875/.876)	20,007/20,020 (.7877/.7882)
W	6,36/6,41 (.250/.252)	5,985/6,015 (.2356/.2368)
B	24,97/25,10 (.983/.988)	23,50/23,75 (.925/.935)

TAPER KEYED SHAFTS :

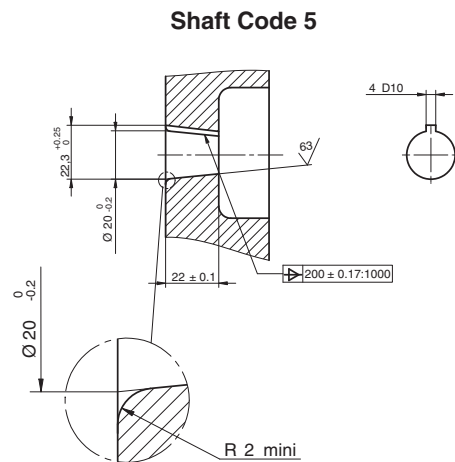
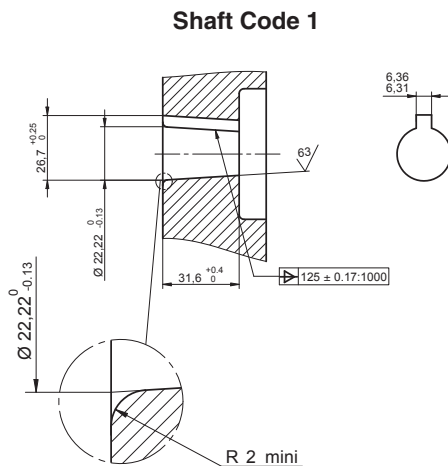

7 . TROUBLESHOOTING GUIDE :

1 . No rotation	a) Is the flow coming at the motor?	<p>a-1) Check the circuit and the hydraulic schematic. Is the piping O.K.?</p> <p>a-2) Check the setting of the main pressure relief valve.</p> <p>a-3) Check if the pump is delivering flow.</p> <p>a-4) Check if the directional valve is allowing the flow to go to the motor. Check if the directional valve is energized. If it is, check if the spool is in its correct position and not sticking in a position that would deviate the flow somewhere else.</p> <p>a-5) Check if a check valve would not have been wrongly mounted.</p>
	b) Is the torque required higher than the system settings?	<p>b-1) Check if the pressure settings are correct.</p> <p>b-2) Check if the load is not superior to the torque capabilities of the motor.</p>
	c) Is the pump OK?	<p>c-1) Check if the pump is working correctly.</p>
	d) How is the motor piped?	<p>d-1) Check the nature of the connectors. If, for example, the "self sealing quick couplings" type connectors are well locked into each other.</p>
2 . Stalls easily	a) Is the load close to the limits of the system?	<p>a-1) Check the relief valve setting value and compare it to the theoretical pressure required to deliver the convenient torque.</p>
	b) Is the flow going to the motor sufficient?	<p>b-1) Check the minimum flow required by the motor.</p> <p>b-2) Check the flow of the pump or the valve feeding the motor.</p>
	c) Is the anti-cavitation valve closed?	<p>c-1) Check that the valve is OK (properly installed, ball seat pollution).</p>
3 . Not enough speed	a) Is the speed lower than desired?	<p>a-1) Check the theoretical displacement of the motor versus the theoretical flow of the pump.</p> <p>a-2) Check that the flow of the pump is really arriving at the motor.</p> <p>a-3) Check that the working pressure & speed are in accordance with the catalogue values of the motor.</p> <p>a-4) Check the fluid temperature. Check then that the low viscosity of the fluid is not having a big effect on the internal leakage of the motor.</p> <p>a-5) Check the air bleed-off.</p>
4 . Erratic speed	a) Is the motor loosing speed erratically?	<p>a-1) Check if the limit of the allowable torque is not reached once a while.</p> <p>a-2) Check if the driven device does not transmit some inconstant load.</p> <p>a-3) Check if the flow coming from the pump is constant.</p>

7 . TROUBLESHOOTING GUIDE :

5 . Unusual noise level	a) Is the motor running?	<p>a-1) Check if there is no air intake that could aerate the fluid.</p> <p>a-2) Check if the motor is not cavitating. It could be that the inertia of the load is such that it drives the motor faster than the flow coming from the pump.</p> <p>a-3) Check if the fluid is suitable for the use.</p> <p>a-4) Check if the air bleed off has been done properly.</p>
	b) When is the motor braking?	<p>b-1) Check the back pressure to see if the replenishment pressure is not too low, leading to cavitation of the motor.</p>
6 . Unusual heat	a) Is the fluid arriving to the motor already hot?	<p>a-1) Check if a cooler is required or, if there is one, if it is well dimensioned.</p> <p>a-2) If there is a cooler, check if it is working (example for water cooler : is the water flow open or sufficient).</p> <p>a-3) Check if the hydraulic circuit is not bringing back the flow directly to the inlet port. Doing so, it would create a small closed circuit not able to cool down the fluid.</p> <p>a-4) Check the quality of the fluid.</p> <p>a-5) Check the velocity of the fluid (6 m/s max.).</p> <p>a-6) Check the filtration unit, its capacity.</p> <p>a-7) Check if the heat does not come from an open bypass valve.</p>
	b) Is the fluid heating up when going through the motor?	<p>b-1) Check the speed of rotation versus the catalogue values.</p> <p>b-2) Check the pressure rating.</p> <p>b-3) Check the fluid type.</p> <p>b-4) Check the viscosity.</p>
7 . Shaft end leakage	a) Is it leaking when pressurized?	<p>a-1) Check that the shaft bearing is not damaged (dark grease leaking out of the ball bearing).</p> <p>a-2) Check that the drain line is not too much pressurized, which could have destroyed the shaft seal inside the motor (fluid leaking outside the shaft bearing race).</p> <p>a-3) Check that the environment, the fluid temperature and viscosity are appropriate (melted grease due to too high temperature or oil leakage due to a burned shaft seal).</p> <p>a-4) Check if there is no high overshoot at start-up that would create a high instant internal leakage.</p> <p>a-5) Check, when using a "quick coupling connector" for the drain line, that it is correctly locked.</p> <p>a-6) Check the alignment of the shafts.</p>
	b) Is it leaking when standing still?	<p>b-1) Check that the shaft bearing is not damaged (dark grease leaking out of the ball bearing).</p> <p>b-2) Check that the drain line is not too much pressurized, which could have destroyed the shaft seal inside the motor (fluid leaking outside the shaft bearing journal).</p> <p>b-3) Check that the environment, the fluid temperature and viscosity are appropriate (melted grease due to too high temperature or oil leakage due to a burned shaft seal).</p>



WARNING – USER RESPONSIBILITY

FAILURE OR IMPROPER SELECTION OR IMPROPER USE OF THE PRODUCTS DESCRIBED HEREIN OR RELATED ITEMS CAN CAUSE DEATH, PERSONAL INJURY AND PROPERTY DAMAGE.

This document and other information from Parker-Hannifin Corporation, its subsidiaries and authorized distributors provide product or system options for further investigation by users having technical expertise.

The user, through its own analysis and testing, is solely responsible for making the final selection of the system and components and assuring that all performance, endurance, maintenance, safety and warning requirements of the application are met. The user must analyze all aspects of the application, follow applicable industry standards, and follow the information concerning the product in the current product catalog and in any other materials provided from Parker or its subsidiaries or authorized distributors.

To the extent that Parker or its subsidiaries or authorized distributors provide component or system options based upon data or specifications provided by the user, the user is responsible for determining that such data and specifications are suitable and sufficient for all applications and reasonably foreseeable uses of the components or systems.

Offer of Sale

Please contact your Parker representation for a detailed "Offer of Sale".

Parker Worldwide

AE – UAE, Dubai
Tel: +971 4 8127100
parker.me@parker.com

AR – Argentina, Buenos Aires
Tel: +54 3327 44 4129

AT – Austria, Wiener Neustadt
Tel: +43 (0)2622 23501-0
parker.austria@parker.com

AT – Eastern Europe, Wiener Neustadt
Tel: +43 (0)2622 23501 900
parker.easteurope@parker.com

AU – Australia, Castle Hill
Tel: +61 (0)2-9634 7777

AZ – Azerbaijan, Baku
Tel: +994 50 2233 458
parker.azerbaijan@parker.com

BE/LU – Belgium, Nivelles
Tel: +32 (0)67 280 900
parker.belgium@parker.com

BR – Brazil, Cachoeirinha RS
Tel: +55 51 3470 9144

BY – Belarus, Minsk
Tel: +375 17 209 9399
parker.belarus@parker.com

CA – Canada, Milton, Ontario
Tel: +1 905 693 3000

CH – Switzerland, Etoy
Tel: +41 (0) 21 821 02 30
parker.switzerland@parker.com

CL – Chile, Santiago
Tel: +56 2 623 1216

CN – China, Shanghai
Tel: +86 21 2899 5000

CZ – Czech Republic, Klecany
Tel: +420 284 083 111
parker.czechrepublic@parker.com

DE – Germany, Kaarst
Tel: +49 (0)2131 4016 0
parker.germany@parker.com

DK – Denmark, Ballerup
Tel: +45 43 56 04 00
parker.denmark@parker.com

ES – Spain, Madrid
Tel: +34 902 330 001
parker.spain@parker.com

FI – Finland, Vantaa
Tel: +358 (0)20 753 2500
parker.finland@parker.com

FR – France, Contamine s/Arve
Tel: +33 (0)4 50 25 80 25
parker.france@parker.com

GR – Greece, Athens
Tel: +30 210 933 6450
parker.greece@parker.com

HK – Hong Kong
Tel: +852 2428 8008

HU – Hungary, Budapest
Tel: +36 1 220 4155
parker.hungary@parker.com

IE – Ireland, Dublin
Tel: +353 (0)1 466 6370
parker.ireland@parker.com

IN – India, Mumbai
Tel: +91 22 6513 7081-85

IT – Italy, Corsico (MI)
Tel: +39 02 45 19 21
parker.italy@parker.com

JP – Japan, Fujisawa
Tel: +81 (0)4 6635 3050

KR – South Korea, Seoul
Tel: +82 2 559 0400

KZ – Kazakhstan, Almaty
Tel: +7 7272 505 800
parker.easteurope@parker.com

LV – Latvia, Riga
Tel: +371 6 745 2601
parker.latvia@parker.com

MX – Mexico, Apodaca
Tel: +52 81 8156 6000

MY – Malaysia, Shah Alam
Tel: +60 3 7849 0800

NL – The Netherlands, Oldenzaal
Tel: +31 (0)541 585 000
parker.nl@parker.com

NO – Norway, Ski
Tel: +47 64 91 10 00
parker.norway@parker.com

NZ – New Zealand, Mt Wellington
Tel: +64 9 574 1744

PL – Poland, Warsaw
Tel: +48 (0)22 573 24 00
parker.poland@parker.com

PT – Portugal, Leca da Palmeira
Tel: +351 22 999 7360
parker.portugal@parker.com

RO – Romania, Bucharest
Tel: +40 21 252 1382
parker.romania@parker.com

RU – Russia, Moscow
Tel: +7 495 645-2156
parker.russia@parker.com

SE – Sweden, Spånga
Tel: +46 (0)8 59 79 50 00
parker.sweden@parker.com

SG – Singapore
Tel: +65 6887 6300

SK – Slovakia, Banská Bystrica
Tel: +421 484 162 252
parker.slovakia@parker.com

SL – Slovenia, Novo Mesto
Tel: +386 7 337 6650
parker.slovenia@parker.com

TH – Thailand, Bangkok
Tel: +662 717 8140

TR – Turkey, Istanbul
Tel: +90 216 4997081
parker.turkey@parker.com

TW – Taiwan, Taipei
Tel: +886 2 2298 8987

UA – Ukraine, Kiev
Tel: +380 44 494 2731
parker.ukraine@parker.com

UK – United Kingdom, Warwick
Tel: +44 (0)1926 317 878
parker.uk@parker.com

US – USA, Cleveland (industrial)
Tel: +1 216 896 3000

US – USA, Lincolnshire (mobile)
Tel: +1 847 821 1500

VE – Venezuela, Caracas
Tel: +58 212 238 5422

ZA – South Africa, Kempton Park
Tel: +27 (0)11 961 0700
parker.southafrica@parker.com

www.parker.com/vanepump

European Product Information Centre
Free phone: 00 800 27 27 5374
(from AT, BE, CH, CZ, DE, EE, ES, FI, FR, IE, IL, IS, IT, LU, MT, NL, NO, PT, SE, SK, UK)

