



Catalog 3900 USA



April 2022

PDF Update: September 11, 2024

Quick Coupling Products

Quick Coupling Division Locations



Minneapolis, MN



Grantsburg, WI



Chetek, WI



Union City, PA



WARNING

FAILURE OR IMPROPER SELECTION OR IMPROPER USE OF THE PRODUCTS DESCRIBED HEREIN OR RELATED ITEMS CAN CAUSE DEATH, PERSONAL INJURY AND PROPERTY DAMAGE.

- This document and other information from Parker-Hannifin Corporation, its subsidiaries and authorized distributors provide product or system options for further investigation by users having technical expertise.
- The user, through its own analysis and testing, is solely responsible for making the final selection of the system and components and assuring that all performance, endurance, maintenance, safety and warning requirements of the application are met. The user must analyze all aspects of the application, follow applicable industry standards, and follow the information concerning the product in the current product catalog and in any other materials provided from Parker or its subsidiaries or authorized distributors.
- To the extent that Parker or its subsidiaries or authorized distributors provide component or system options based upon data or specifications provided by the user, the user is responsible for determining that such data and specifications are suitable and sufficient for all applications and reasonably foreseeable uses of the components or systems.



Dave Reede Photo

111 Breakwater Cove
Winnipeg, MB R3X 1G3

Phone: 204 553 7445

E-Mail: dave@davereedphoto.mb.ca

www.davereedphoto.mb.ca

The excellent agricultural photography in this Pioneer catalog has been provided and authorized by Canadian photographer Dave Reede.

Dave is a stock and assignment photographer. Although he photographs a variety of subject matter, he is well known for his images of agriculture and farm life. He has been passionately photographing agriculture since 1986 when he arrived on the Canadian Prairies. Dave has been documenting some farm operations for the past twenty years. His unique style of agriculture photography is sought after by many of North America's well-known companies and organizations in the agriculture sector. His agriculture imagery is also used world-wide on an ongoing basis, for uses ranging from editorial to major advertising campaigns. Dave is also an accomplished photographer of the landscape and outdoor recreation.

Whether riding on top of a combine to get a different view, shooting from a variety of stepladders, or diving out of the way of an oncoming combine, Dave creates images with creativity and impact. Over the years Dave has worked diligently to get a unique, in-depth coverage of all aspects of prairie agriculture, including farm life, crops, equipment, harvest, chemical application, agricultural landscapes and farmers.

Thanks Dave for your special touch on this catalog.



Table Of Contents

Pioneer has been “The Farmer’s Choice” for more than 70 years, and it is the world leader in quick coupling products for the agricultural industry.

These products are manufactured in state-of-the-art manufacturing plants using the latest technologies to provide you with products of the highest quality and durability.

Pioneer offers the widest range of quick couplings on the market, and has a product for nearly every agricultural application.

Quick Couplings

Agricultural Couplings and Accessories

8010 Series	2
4000 Series	3
4200 Series	6
6600 Series	8
8200 Series	11
8450 Series	13
9200 Series	14
9500 Series	17
5000 Series	18
Clamps.....	20
Agricultural QC Adapters	21
Original Equipment Products.....	23
OEM Aftermarket	26
Retail Products.....	44

Hydraulic Couplings

3000 Series	49
FF/FC Series	51
FEM/FEC Series.....	55
FS Series	59
ST Series	62
1163 Series	65

Pneumatic Couplings

Pneumatic Industrial Interchange Nipples.....	66
20 Series	69
Rectus 25 Series (formerly RF Series).....	72
Rectus 21, 23, 30 Series (formerly HF Series).....	75
UC Series (Universal).....	78
E-z-mate Series	79

Check Valves

DT Series.....	81
----------------	----

Appendix

Safety Guide	86
Fluid Compatibility Chart.....	88
Offer of Sale	93



The 8010 Series is the standard male tip of the agricultural industry, developed and proven by Pioneer in over 70 years of farm service. These nipples will connect with all 1/2" body size 4000, 4200, 5000, 6600, 8200, 8450, and 9200 series couplers. Tips are offered in three valve styles; ball, poppet, and DC (connect under pressure) poppet. The DC version allows connection under system pressure on the coupler side and residual pressure (up to 3000 psi) on the nipple side.

Features:

- Meets dimensional requirements of ISO 5675
- DC poppet style offers connect under pressure option
- Poppet style valve prevents uncoupled leakage of hydraulic fluid
- Hardened locking ball groove prevents Brinelling
- Shielded valve and positive valve stop eliminates flow checking
- Protective zinc plating with clear trivalent chromate finish

Applications include:

- Tractors
- Implements
- Agricultural attachments

8010 Series Universal Nipple							
Body Size	Nipple Part Number	Port End	Valve Type	Length	Largest Diameter	Wrench Flats	Weight (lbs.)
1/2	8010-4	1/2-14 NPTF	Ball	1.95	1.23	1.06	0.20
1/2	8010-4P	1/2-14 NPTF	Poppet	1.95	1.23	1.06	0.20
1/2	8010-5	3/4-14 NPTF	Ball	2.14	1.44	1.25	0.25
1/2	8010-5P	3/4-14 NPTF	Poppet	2.14	1.44	1.25	0.25
1/2	8010-15	3/4-16 ORB	Ball	1.95	1.23	1.06	0.20
1/2	8010-15P	3/4-16 ORB	Poppet	1.95	1.23	1.06	0.20
1/2	8010-16	7/8-14 ORB	Ball	1.95	1.23	1.06	0.25
1/2	8010-16P	7/8-14 ORB	Poppet	1.95	1.23	1.06	0.25
1/2	8010-20PM	M22 X 1.5	Poppet	2.14	1.23	1.06	0.25
1/2	8010-29BSPP	1/2-14 BSPP	Ball	1.95	1.18	1.06	0.25

8010 Series Connect-Under-Pressure Nipple*							
Body Size	Nipple Part Number	Port End	Valve Type	Length	Largest Diameter	Wrench Flats	Weight (lbs.)
1/2	8010-4P-DC	1/2-14 NPTF	Poppet	1.95	1.23	1.06	0.20
1/2	8010-15P-DC	3/4-16 O-Ring Boss	Poppet	1.95	1.23	1.06	0.25

* Not for use with 9200 Series Couplers

8010 Series Specifications				
Body Size	Rated Flow	Rated Pressure	Temperature	Poppet Seal Material
1/2	12 gpm	3000 psi	-40° F to +250° F	Nitrile

8010 Series Dust Cap			
Body Size	Dust Cap	Color/Material	Weight (lbs.)
1/2	5209-4M	Black Rubber	.04
1/2	5209-4M-BU	Blue Rubber	.04
1/2	5209-4M-GR	Green Rubber	.04
1/2	5209-4M-RE	Red Rubber	.04
1/2	5209-4M-YE	Yellow Rubber	.04





The 4000 Series brings to the industry a proven design for use on agricultural machinery and other rugged applications.

Features:

- Accepts ISO 5675 universal tips
- Basic operation where coupler sleeve is manually retracted to allow connection with male tip
- Critical parts are induction hardened
- Ball and poppet valve options
- Protective zinc plating with clear trivalent chromate finish

Applications include:

- Hydraulic Loaders
- Add-on hydraulic circuits
- Hydraulic tools
- Snow plow attachments

4000 Series Specifications:						
Body Size	Rated Flow (gpm)	Rated Pressure (psi)	Temperature	Body Material	Sleeve Type	Seal Material
1/4	3	3000	-40° F to +250° F	Steel	Manual Connect	Nitrile
3/8	6					
1/2	12					
3/4	28					
1	50					

Performance:

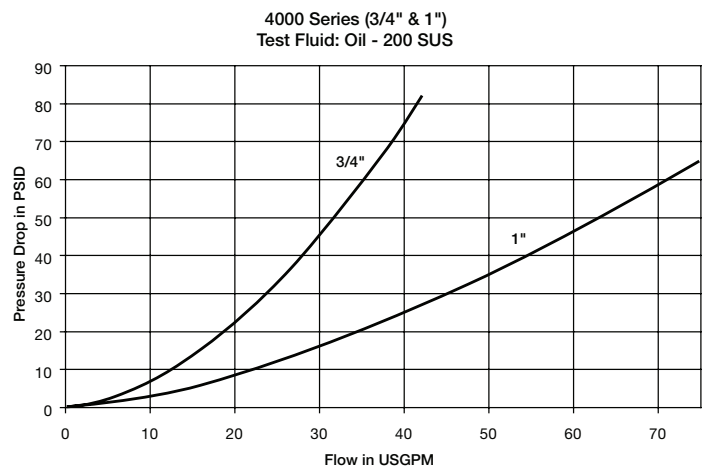
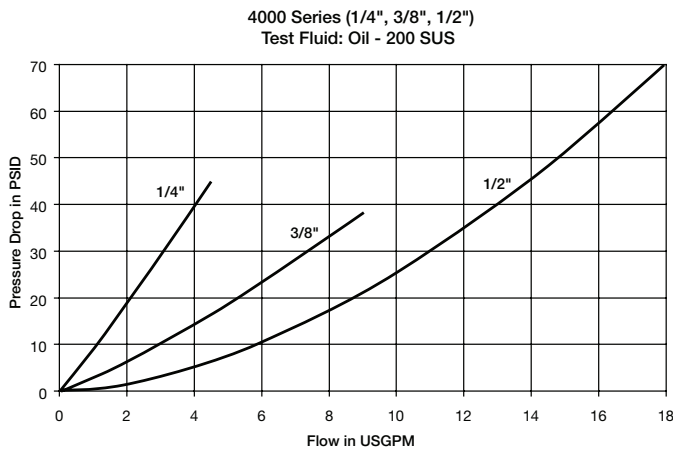



4000 Series Couplers



Body Size	Coupler Part Number	Port End	Valve Type	Length	Largest Diameter	Wrench Flats	Weight (lbs.)	Complete Coupling Part Number
1/4	4050-2P	1/4-18 NPTF	Poppet	2.18	1.06	0.88	0.24	4000-2P
1/4	4050-2P-T8M	3/4-16 ORB (Male)	Poppet	1.80	1.06	0.88	0.21	-
1/4	4050-T6	9/16-18 ORB	Poppet	2.18	1.06	0.88	0.27	-
1/4	4050P-T6*	9/16-18 ORB	Poppet	2.43	1.33	0.88	0.33	-
3/8	4050-3P	3/8-18 NPTF	Poppet	2.31	1.33	0.94	0.51	4000-3P
1/2	4050-4	1/2-14 NPTF	Ball	2.60	1.50	1.06	0.58	4000-4
1/2	4050-4P	1/2-14 NPTF	Poppet	2.60	1.50	1.06	0.58	4000-4P
1/2	4050-5	3/4-14 NPTF	Ball	2.69	1.50	1.13	0.71	4000-5
1/2	4050-5P	3/4-14 NPTF	Poppet	2.69	1.50	1.13	0.71	4000-5P
1/2	4050-15	3/4-16 ORB	Ball	2.81	1.50	1.06	0.64	4000-15
1/2	4050-15P	3/4-16 ORB	Poppet	2.81	1.50	1.06	0.64	4000-15P
1/2	4050-16	7/8-14 ORB	Ball	2.75	1.50	1.06	0.59	4000-16
1/2	4050-16P	7/8-14 ORB	Poppet	2.75	1.50	1.06	0.59	4000-16P
1/2	4050-29BSPP	1/2-14 BSPP	Ball	2.68	1.50	1.06	0.59	-
3/4	4150-5	3/4-14 NPTF	Ball	3.06	1.87	1.38	1.00	4100-5
1	4050-6P	1-11 1/2 NPTF	Poppet	3.84	2.08	1.63	1.89	4000-6P

* Special Push/Pull Sleeve

8010 Series Nipples



Poppet Ball Valve



See page A-2 for additional ISO 5675 tip options.

Body Size	Nipple Part Number	Port End	Valve Type	Length	Largest Diameter	Wrench Flats	Weight (lbs.)	Complete Coupling Part Number
1/4	4010-2P	1/4-18 NPTF	Poppet	1.48	0.87	0.75	0.08	4000-2P
1/4	4010-T6	9/16-18 ORB	Poppet	1.60	0.87	0.75	0.09	-
3/8	4010-3P	3/8-18 NPTF	Poppet	1.60	1.08	0.94	0.16	4000-3P
1/2	8010-4	1/2-14 NPTF	Ball	1.95	1.23	1.06	0.20	4000-4
1/2	8010-4P	1/2-14 NPTF	Poppet	1.95	1.23	1.06	0.20	4000-4P
1/2	8010-5	3/4-14 NPTF	Ball	2.14	1.44	1.25	0.25	4000-5
1/2	8010-5P	3/4-14 NPTF	Poppet	2.14	1.44	1.25	0.25	4000-5P
1/2	8010-15	3/4-16 ORB	Ball	1.95	1.23	1.06	0.20	4000-15
1/2	8010-15P	3/4-16 ORB	Poppet	1.95	1.23	1.06	0.20	4000-15P
1/2	8010-16	7/8-14 ORB	Ball	1.95	1.23	1.06	0.25	4000-16
1/2	8010-16P	7/8-14 ORB	Poppet	1.95	1.23	1.06	0.25	4000-16P
1/2	8010-29BSPP	1/2-14 BSPP	Ball	1.95	1.23	1.06	0.25	-
3/4	4110-5	3/4-14 NPTF	Ball	1.81	1.52	1.31	0.50	4100-5
1	4010-6P	1-11 1/2 NPTF	Poppet	2.79	1.88	1.63	0.62	4000-6P





4050 Series Replacement O-Rings			
Body Size	Material	Part Number	Durometer
1/4	Nitrile	50001-113-0260	90
3/8	Nitrile	50001-116-0260	90
1/2	Nitrile	50001-211-0260	90
3/4	Nitrile	50001-215-0010	70
1	Nitrile	50001-218-0260	90

4000 Series Dust Plugs and Caps				
Body Size	Dust Plug	Color/Material	Dust Cap	Weight (lbs.)
1/4	5205-2M	Black Rubber	5209-2M	.02
3/8	5205-3M	Black Rubber	5209-3M	.03
1/2	5205-4M	Black Rubber	5209-4M	.04
1/2	5205-4M-BU	Blue Rubber	5209-4M-BU	.04
1/2	5205-4M-GR	Green Rubber	5209-4M-GR	.04
1/2	5205-4M-RE	Red Rubber	5209-4M-RE	.04
1/2	5205-4M-YE	Yellow Rubber	5205-4M-YE	.04
1/2	5005-4	Steel w/Chain	5009-4	.21
3/4	5205-5M	Black Rubber	5209-5M	.05
1	5205-6M	Black Rubber	5209-6M	.06





The 4200 Series brings to the industry a proven design for use on agricultural machinery and other rugged applications where a breakaway feature is desirable.

Features:

- Accepts ISO 5675 universal tips
- Grooves in sleeve to accommodate retaining rings for bulkhead mounting
- One-handed push-to-connect operation when coupler is clamp mounted
- 1/2" body size couplers are compatible with 5001-4 and 5006-4 breakaway clamps
- Critical parts are induction hardened
- Ball and poppet valve options
- Protective zinc plating with clear trivalent chromate finish

Applications include:

- Hydraulic Loaders
- Add-on hydraulic circuits
- Implement breakaway
- Hydraulic tools

4200 Series Specifications:

Body Size	Rated Flow (gpm)	Rated Pressure (psi)	Temperature	Body Material	Sleeve Type	Seal Material
3/8	6	3000	-40° F to +250° F	Steel	Push/Pull/ Breakaway	Nitrile
1/2	12					

Performance:

4200 Series (3/8" & 1/2")
Test Fluid: Oil - 200 SUS

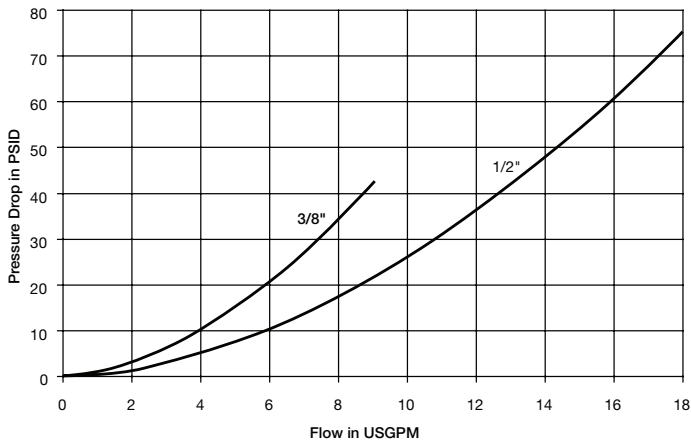



4200 Series Couplers



Body Size	Coupler Part Number	Port End	Valve Type	Length	Largest Diameter	Wrench Flats	Weight (lbs.)	Complete Coupling Part Number
3/8	4250-3P	3/8-18 NPTF	Poppet	2.31	1.31	0.81	0.39	4200-3P
1/2	4250-4	1/2-14 NPTF	Ball	2.68	1.50	0.94	0.55	4200-4
1/2	4250-4P	1/2-14 NPTF	Poppet	2.68	1.50	0.94	0.55	4200-4P
1/2	4250-15	3/4-16 ORB	Ball	2.68	1.50	0.94	0.55	4200-15
1/2	4250-15P	3/4-16 ORB	Poppet	2.68	1.50	0.94	0.55	4200-15P

8010 Series Nipples



See page A-2 for additional ISO 5675 tip options.

Body Size	Nipple Part Number	Port End	Valve Type	Length	Largest Diameter	Wrench Flats	Weight (lbs.)	Complete Coupling Part Number
3/8	4010-3P	3/8-18 NPTF	Poppet	1.60	1.08	0.94	0.16	4200-3P
1/2	8010-4	1/2-14 NPTF	Ball	1.95	1.23	1.06	0.20	4200-4
1/2	8010-4P	1/2-14 NPTF	Poppet	1.95	1.23	1.06	0.20	4200-4P
1/2	8010-15	3/4-16 ORB	Ball	2.06	1.23	1.06	0.20	4200-15
1/2	8010-15P	3/4-16 ORB	Poppet	2.06	1.23	1.06	0.20	4200-15P

4200 Series Accessories



Body Size	Part Number	Clamp Type	Weight (lbs.)
1/2	5001-4	Single	.66
1/2	5006-4	Double	.81

4200 Series Dust Plugs and Caps



Body Size	Dust Plug	Color/Material	Dust Cap	Weight (lbs.)
3/8	5205-3M	Black Rubber	5209-3M	.03
1/2	5205-4M	Black Rubber	5209-4M	.04
1/2	5205-4M-BU	Blue Rubber	5209-4M-BU	.04
1/2	5205-4M-GR	Green Rubber	5209-4M-GR	.04
1/2	5205-4M-RE	Red Rubber	5209-4M-RE	.04
1/2	5205-4M-YE	Yellow Rubber	5205-4M-YE	.04
1/2	5005-4	Steel w/Chain	5009-4	.21

4250 Series Replacement O-Rings

Body Size	Material	Part Number	Durometer
3/8	Nitrile	50001-116-0260	90
1/2	Nitrile	50001-211-0260	90





The 6600 Series are versatile for use in a wide range of hydraulic applications where fluid lines require connection and disconnection for equipment operation or maintenance

Features:

- Accepts ISO 7241-1, Series A compliant nipples
- Poppet valves and a metal perch to maintain valve alignment and prevent flow checking
- Coupler sleeve and nipple body are hardened to be damage resistant
- Standard end configurations include female pipe and straight thread ORB
- Protective zinc plating with clear trivalent chromate finish

Applications include:

- Snow plows
- Truck trailer connections
- Mobile applications
- Attachments

6600 Series Specifications:

Body Size	Rated Flow (gpm)	Rated Pressure (psi)	Temperature	Body Material	Sleeve Type	Seal Material
1/4	0.8	5000	-40° F to +250° F	Steel	Manual Connect	Nitrile
3/8	6	4000				
1/2	12	4000				
3/4	28	4000				
1	50	4000				

Performance:

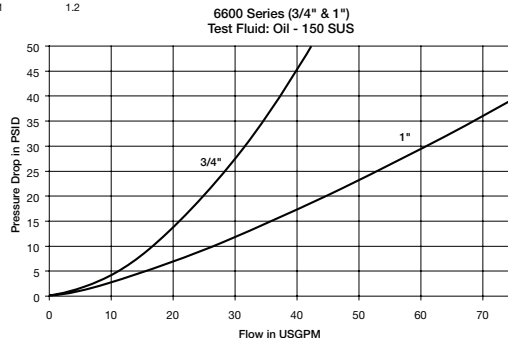
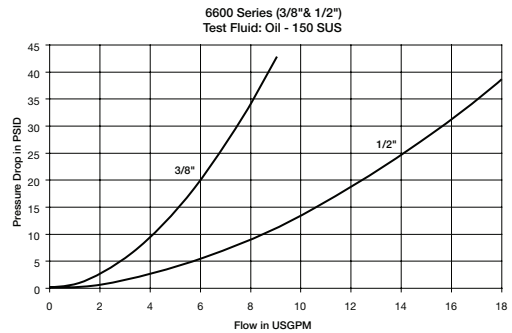
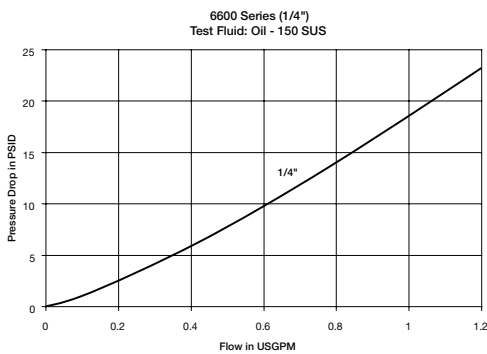



6600 Series Couplers



Body Size	Coupler Part Number	Port End	Valve Type	Length	Largest Diameter	Wrench Flats	Weight (lbs.)
1/4	6601-2-4	1/8 -27 NPTF	Poppet	1.85	1.08	0.88	0.27
1/4	6601-4-4	1/4 -18 NPTF	Poppet	1.85	1.08	0.88	0.26
3/8	6601-6-6	3/8 -18 NPTF	Poppet	2.18	1.27	1.06	0.39
3/8	6608-6-6	9/16 -18 ORB	Poppet	2.18	1.27	1.06	0.38
1/2	6601-8-10	1/2 -14 NPTF	Poppet	2.75	1.52	1.25	0.67
1/2	6601-12-10	3/4 -14 NPTF	Poppet	2.88	1.52	1.38	0.71
1/2	6608-8-10	3/4 -16 ORB	Poppet	2.74	1.52	1.25	0.67
1/2	6608-10-10	7/8 -14 ORB	Poppet	2.79	1.52	1.25	0.64
1/2	6608-12-10	1 1/16 -12 ORB	Poppet	3.01	1.52	1.38	0.77
3/4	6601-12-12	3/4 -14 NPTF	Poppet	3.36	1.90	1.62	1.31
3/4	6608-12-12	1 1/16 -12 ORB	Poppet	3.35	1.90	1.62	1.31
1	6601-16-16	1-11 1/2 NPTF	Poppet	4.11	2.14	1.88	1.93
1	6608-16-16	1 5/16 - 12 ORB	Poppet	4.11	2.14	1.88	1.75

6600 Series Nipples



Body Size	Nipple Part Number	Port End	Valve Type	Length	Largest Diameter	Wrench Flats	Weight (lbs.)
1/4	6602-2-4	1/8 -27 NPTF	Poppet	1.41	0.65	0.56	0.05
1/4	6602-4-4	1/4 -18 NPTF	Poppet	1.41	0.87	0.75	0.07
3/8	6602-6-6	3/8 -18 NPTF	Poppet	1.63	1.01	0.88	0.11
3/8	6610-6-6	9/16 -18 ORB	Poppet	1.63	1.01	0.88	0.13
1/2	6602-8-10	1/2 -14 NPTF	Poppet	2.08	1.23	1.06	0.21
1/2	6602-12-10	3/4 -14 NPTF	Poppet	2.30	1.59	1.38	0.33
1/2	6610-8-10	3/4 -16 ORB	Poppet	2.08	1.23	1.06	0.22
1/2	6610-10-10	7/8 -14 ORB	Poppet	2.08	1.30	1.12	0.21
1/2	6610-12-10	1 1/16 -12 ORB	Poppet	2.30	1.59	1.38	0.33
3/4	6602-12-12	3/4 - 14 NPTF	Poppet	2.55	1.59	1.38	0.49
3/4	6610-12-12	1 1/16 -12 ORB	Poppet	2.55	1.59	1.38	0.47
1	6602-16-16	1-11 1/2 NPTF	Poppet	3.10	1.88	1.62	0.75
1	6610-16-16	1 5/16 -12 ORB	Poppet	3.10	2.17	2.08	0.72

6600 Series Replacement Parts	1/4	3/8	1/2	3/4	1
O-Rings - Nitrile	50001-112-0010	50001-115-0010	50001-211-0010	50001-123-0010	50001-126-0010
Back-up Rings	4118006	4118005	50-140-4	4138001	4148002

1/8"	1/4"	3/8"	1/2"	5/8"	3/4"	1"	1-1/4"	1-1/2"
------	------	------	------	------	------	----	--------	--------



6600 Series Dust Caps and Plugs



Body Size	Dust Plug (Coupler)	Color/Material	Dust Cap (Nipple)	Weight (lbs.)
1/4	H1-65M	Black Rubber	H1-66M	.02
3/8	TR-37	Black Rubber	TR-37	.04
1/2	5205-4M	Black Rubber	5209-4M	.04
3/4	6659-12M	Black Rubber	6657-12M	.06
1	6659-16M	Black Rubber	6657-16M	.08





Pioneer's 8200 Series unique valve design allows connection while either or both the coupler and nipple are under pressure. Valves in both halves remain closed, opening only when system pressure has been relieved on the female body and then reapplied. This pressure sequence may be done with either an open center or a closed center hydraulic system that has a control valve.

Features:

- Accepts ISO 5675 universal tips
- Connect under system pressure on the coupler side and residual pressure on the nipple side
- Sleeve designed to accommodate bracket mounting
- One-handed push-to-connect operation when coupler is clamp mounted
- 1/2" body size couplers are compatible with 5001-4 and 5006-4 breakaway clamps
- Critical parts are induction hardened
- Protective zinc plating with clear trivalent chromate finish

Applications include:

- Tractors
- Mid-sized agricultural equipment
- Agricultural attachments requiring breakaway

8200 Series Specifications

Body Size	Rated Flow	Rated Pressure	Temperature	Body Material	Sleeve Type	Seal Material
1/2	12 gpm	3000 psi	-40° F to +250° F	Steel	Push-pull/break away	Nitrile



Performance

8200 Series (1/2")
Test Fluid: Oil - 200 SUS

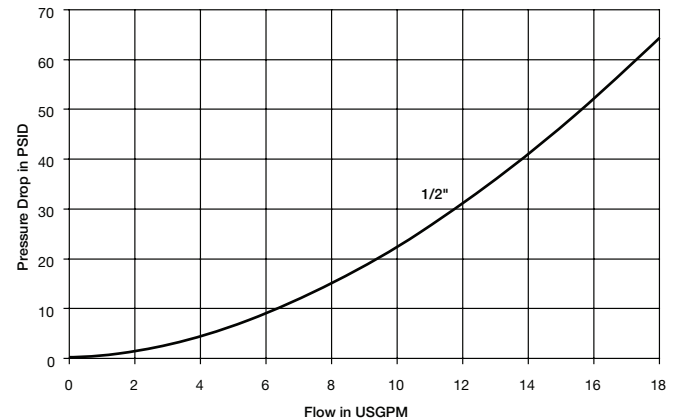



8200 Series Couplers - Female Thread



Body Size	Coupler Part Number	Port End	Valve Type	Length	Largest Diameter	Wrench Flats	Weight (lbs.)	Complete Coupling Part Number
1/2	8250-4	1/2-14 NPSF	Poppet	3.29	1.50	0.87	0.63	8200-4
1/2	8250-15	3/4-16 ORB	Poppet	3.29	1.50	0.87	0.63	8200-15
1/2	8250-16	7/8-14 ORB	Poppet	3.29	1.50	0.87	0.63	8200-16

8010 Series Nipples - Female Thread



Poppet



See page A-2 for additional ISO 5675 tip options.

Body Size	Coupler Part Number	Port End	Valve Type	Length	Largest Diameter	Wrench Flats	Weight (lbs.)	Complete Coupling Part Number
1/2	8010-4	1/2-14 NPTF	Ball	1.95	1.23	1.06	0.20	8200-4
1/2	8010-4P	1/2-14 NPTF	Poppet	1.95	1.23	1.06	0.20	-
1/2	8010-15	3/4 -16 ORB	Ball	1.95	1.23	1.06	0.20	8200-15
1/2	8010-15P	3/4 -16 ORB	Poppet	1.95	1.23	1.06	0.20	-
1/2	8010-16	7/8 -14 ORB	Ball	1.95	1.23	1.06	0.25	8200-16
1/2	8010-16P	7/8 -14 ORB	Poppet	1.95	1.23	1.06	0.25	-

8200 Series Replacement Parts

Body Size	Part Number	Description	Material
1/2	50005-211-0200	O-Ring	Nitrile

8200 Series Dust Caps and Plugs



Body Size	Dust Plug (Coupler)	Color/Material	Dust Cap (Nipple)	Weight (lbs.)
1/2	5205-4M	Black Rubber	5209-4M	.04
1/2	5205-4	Steel w/Chain	5209-4	.21
1/2	5205-4M-BU	Blue Rubber	5209-4M-BU	.04
1/2	5205-4M-GR	Green Rubber	5209-4M-GR	.04
1/2	5205-4M-RE	Red Rubber	5205-4M-RE	.04
1/2	5005-4M-YE	Yellow Rubber	5009-4M-YE	.04



reapplied. This pressure sequence may be done with either an open center or a closed center hydraulic system that has a control valve. The enclosed outer housing allows all connecting motion to be internal thereby preventing dust and dirt build-up around the sleeve mechanism. Suitable for rigid mount or use with a breakaway clamp.

Features:

- Accepts ISO 5675 universal tips
- Straight thread ORB fitting end allows direct mounting to a control valve or rigid tubing
- Outer housing keeps dust and dirt away from the sleeve mechanism
- Connect under system pressure on the coupler side and on the nipple side
- One-handed push-to-connect operation when coupler is clamp or rigid mounted
- Couplers are compatible with 5006-4 breakaway clamps
- Protective zinc plating with clear trivalent chromate finish

Pioneer's 8450 Series unique valve design allows connection while either or both the coupler and nipple are under pressure. Valves in both halves remain closed, opening only when system pressure has been relieved on the female body and then

Applications include:

- Tractors
- Mid-sized agricultural equipment

8450 Series Specifications

Body Size	Rated Flow	Rated Pressure	Temperature	Body Material	Sleeve Type	Seal Material
1/2"	12 gpm	3000 psi	-40° F to +250° F	Steel	Rigid Mount	Nitrile
Connect Force			Disconnect Force			
70 lbs. max at 0 psi		100 lbs. max at 3000 psi	40 lbs. min at 0 psi		165 lbs. max at 3000 psi	

8450 Series Couplers



Body Size	Coupler Part Number	Port End	Valve Type	Flats	Sleeve Diameter	Clamp to Use	Dust Plug
1/2	8450-16	7/8-14 ORB (Female)	Poppet	1.38	1.50	5006-4	8405-4 or 8407-4
1/2	8450-16M	7/8-14 ORB (Male)	Poppet	1.38	1.50	5006-4	8405-4 or 8407-4

8010 Series Nipples



Poppet



Ball Valve

[See page A-2 for additional ISO 5675 tip options.](#)

Body Size	Coupler Part Number	Port End	Valve Type	Length	Largest Diameter	Wrench Flats	Weight (lbs.)
1/2	8010-16	7/8-14 ORB (Female)	Ball	1.95	1.23	1.06	0.25
1/2	8010-16P	7/8-14 ORB (Female)	Poppet	1.95	1.23	1.06	0.25

8450 Series Dust Caps and Plugs



Dust Cap for Nipple	5209-4M
Dust Cover for Coupler	8511-022 Automatic
Dust Plug for Coupler	8512-030 Standard



The 9200 Series coupler allows zero pressure connection and disconnection while either or both the coupler and nipple are under pressure. A lever operated cam locks both coupler and nipple valves in the open or closed position. "Closed", the flow is shut off at the coupler, allowing easy, zero pressure connect and disconnect. Valves in the "Open" position are locked in place and unaffected by hydraulic surges. Valves will automatically close if the coupling is accidentally disconnected.

Features:

- Accepts ISO 5675 universal tips
- Premier connect under pressure coupling
- Locked valves prevent flow checking
- Color coded levers to identify raise and lower lines
- Couplers are compatible with 9006-4 double breakaway clamp
- Protective zinc plating with clear trivalent chromate finish

Applications include:

- Tractors
- Implements
- Agricultural attachments requiring breakaway

9200 Series Specifications:

Body Size	Rated Flow	Rated Pressure	Temperature	Body Material	Sleeve Type	Seal Material
1/2	12 gpm	3000 psi	-40° F to +250° F	Steel	Double Acting	Nitrile

Performance:

9200 Series (1/2")
Test Fluid: Oil - 200 SUS

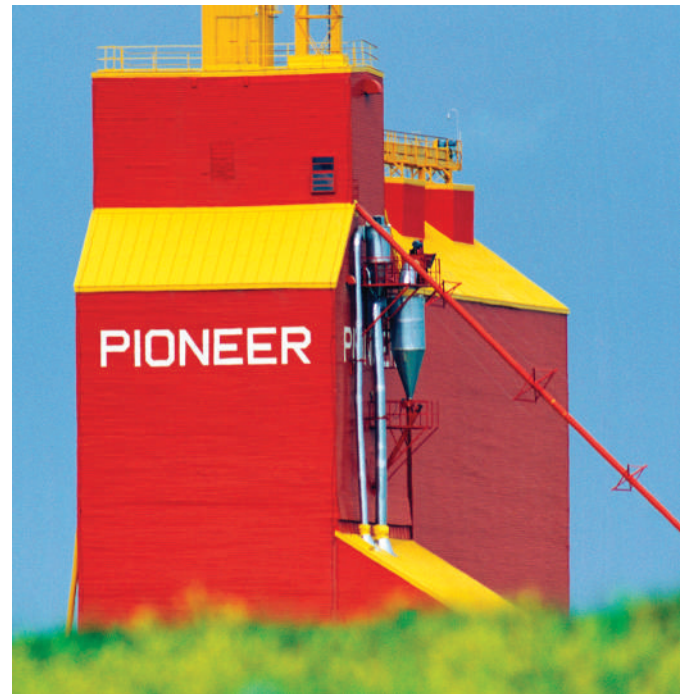
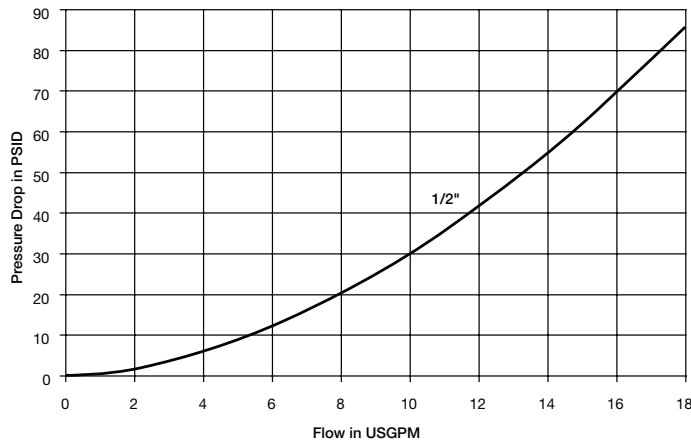



9200 Series Couplers

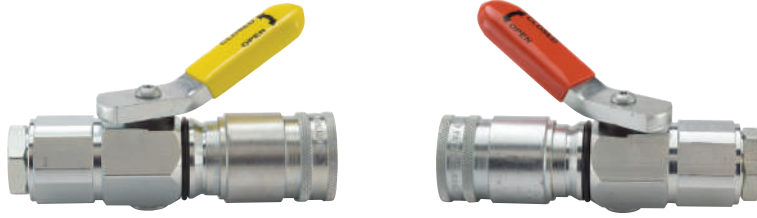

Body Size	Coupler Part Number	Port End	Valve Type	Orientation	Length	Largest Diameter	Wrench Flats	Weight (lbs.)
1/2	9250-4L	1/2-14 NPTF	Poppet	Left hand – yellow grip	5.37	1.50	1.13	2.02
1/2	9250-4L-UPC (bar coded for retail)	1/2-14 NPTF	Poppet	Left hand – yellow grip	5.37	1.50	1.13	1.92
1/2	9250-4R	1/2-14 NPTF	Poppet	Right hand – red grip	5.37	1.50	1.13	1.92
1/2	9250-4R-UPC (bar coded for retail)	1/2-14 NPTF	Poppet	Right hand – red grip	5.37	1.50	1.13	1.95
1/2	9250-4-320*	1/2-14 NPTF	Poppet	Left hand – yellow grip	5.37	1.50	1.13	1.98
1/2	9250-6-320*	9/16-18 UNF	Poppet	Left hand – yellow grip	5.37	1.50	1.13	2.06
1/2	9250-15L	3/4-16 UNF	Poppet	Left hand – yellow grip	5.37	1.50	1.13	1.92
1/2	9250-15R	3/4-16 UNF	Poppet	Right hand – red grip	5.37	1.50	1.13	1.92
1/2	9250-15-320*	3/4-16 UNF	Poppet	Left hand – yellow grip	5.37	1.50	1.13	2.06
1/2	9250-16L	7/8-14 UNF	Poppet	Left hand – no grip	5.37	1.50	1.13	1.88
1/2	9250-16L-YE	7/8-14 UNF	Poppet	Left hand – yellow grip	5.37	1.50	1.13	1.89
1/2	9250-16R	7/8-14 UNF	Poppet	Right hand – no grip	5.37	1.50	1.13	1.88
1/2	9250-16R-RE	7/8-14 UNF	Poppet	Right hand – red grip	5.37	1.50	1.13	1.89
1/2	9250-16-320*	7/8-14 UNF	Poppet	Left hand – yellow grip	5.37	1.50	1.13	2.06
1/2	9250-334**	9/16-18 UNF	Poppet	Left hand – yellow grip	5.37	1.50	1.13	2.15

* -320 indicates lower sleeve spring force for easier connection when coupler is not mounted in a clamp.

** -334 couplers connect with 1/4" ISO 7241-B series nipples.

8010 Series Nipples



Poppet



Ball Valve

See page A-2 for additional ISO 5675 tip options.

Body Size	Coupler Part Number	Port End	Valve Type	Length	Largest Diameter	Wrench Flats	Weight (lbs.)
1/4	H2-63-T6*	9/16-18 ORB	Poppet	1.54	1.01	0.88	0.10
1/2	8010-4	1/2-14 NPTF	Ball	1.95	1.23	1.06	0.20
1/2	8010-4P	1/2-14 NPTF	Poppet	1.95	1.23	1.06	0.20
1/2	8010-15	3/4-16 ORB	Ball	1.95	1.23	1.06	0.20
1/2	8010-15P	3/4-16 ORB	Poppet	1.95	1.23	1.06	0.20
1/2	8010-16	7/8-14 ORB	Ball	1.95	1.23	1.06	0.25
1/2	8010-16P	7/8-14 ORB	Poppet	1.95	1.23	1.06	0.25

* Connects with 9250-334 couplers





9200 Series Replacement Parts

Body Size	Part Number	Description	Weight (lbs.)
1/2	50001-211-0260	Interface O-Ring	.01
1/2	92-805-L4	Replacement Lever (Left hand)	.23
1/2	92-805-R4	Replacement Lever (Right hand)	.23
1/2	92-806-4	Replacement Yellow Grip (Left hand)	.01
1/2	92-807-4	Replacement Red Grip (Right hand)	.01
1/2	92-813-4	Replacement Black Grip (Right hand)	.01
1/2	92-814-L4	Replacement Cam Stop (Left hand)	.01
1/2	92-814-R4	Replacement Cam Stop (Right hand)	.01
1/2	92-906-4A	Wave Washer	.01

9200 Series Accessories



Body Size	Part Number	Clamp Type
1/2	9006-4	Breakaway - double
1/2	9507-4-1H	Automatic Dust Cover

NOTE: 9507-4-1H automatic dust cover cannot be used without the 9006-4 clamp.

9200 Series Dust Caps and Plugs

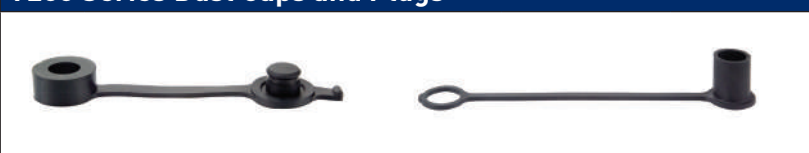

Body Size	Coupler Dust Cover	Color/Material	Nipple Dust Cap	Weight (lbs.)
1/2	9507-4-1	Black Rubber	5209-4M	.04

NOTE: 9507-4-1 rubber dust cover can be used with or without the 9006-4 clamp.





9500 Series Kits combines two color coded 9250 couplers with a 9006-4 clamp and dust protection. The dust covers automatically close when the male tip is removed and are color coordinated with the coupler lever handles to easily identify raise and lower lines. The 9502 Series Kits are preassembled and ready for use. 9250 couplers accept 8010 (ISO 5675) tips and are not included with the kit.

Kit contents:

- (1) 9250 Coupler (right hand orientation)
- (1) 9250 Coupler (left hand orientation)
- (1) 9006-4 Clamp Assembly
- (1) 9507-4-1H Automatic Dust Cover Assembly



Open Position



9250 Series

By turning the rugged, color-coded lever to "Open" you lock open the valves in both the female body and the male tip, so they are unaffected by rapid variations in fluid flow.

Turning the lever to Open without a male tip in place will not result in oil flow. The 9250 Series design prevents this from happening.

Valves will close automatically in the case of a breakaway.

Closed Position



9250 Series

In the Closed position the 9250 shuts off oil flow at the remote outlet. This allows for easy, sprayless, zero-pressure connecting or disconnecting and for additional safety when working on an implement.

Levers are color-coded to identify Raise and Lower lines.

Body Size	Part Number	Port End	Description	Rated Pressure (psi)	Sleeve Diameter	Flats	Clamp	Dust Cover
1/2	9500-4	1/2-14 NPTF	Kit	3000	1.50	1.13	9006-4	9507-4-1H
1/2	9500-16	7/8-14 ORB	Kit	3000	1.50	1.13	9006-4	9507-4-1H
1/2	9502-4	1/2-14 NPTF	Kit (assembled)	3000	1.50	1.13	9006-4	9507-4-1H





The 5000 Series is an economical coupling that can be connected under pressure where tools can be used to make the connection. The coupler and nipple are connected and then the valves are opened from tightening the threaded union on the back of the coupler body. Unscrewing the body threads will permit the valves to close and the coupler sleeve can be retracted to release the nipple.

Features:

- Accepts ISO 5675 universal tips
- Manual, threaded actuation, connect under pressure coupling
- Protective zinc plating with clear trivalent chromate finish

Applications include:

- Lubrication systems
- Hydraulic tools
- Attachments

5000 Series Specifications

Body Size	Rated Flow	Rated Pressure	Temperature	Body Material	Sleeve Type	Seal Material
1/2	12 gpm	2500 psi	-40° F to +250° F	Steel	Single Acting	Nitrile

Performance:

5000 Series (1/2")
 Test Fluid: Oil - 200 SUS

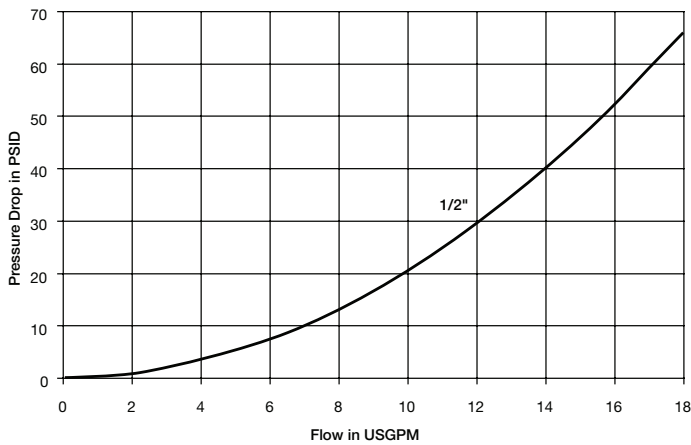



5000 Series Couplers



Body Size	Coupler Part Number	Port End	Valve Type	Length	Largest Diameter	Wrench Flats	Weight (lbs.)	Complete Coupling Part Number
1/2	5050-4	1/2-14 NPTF	Ball	2.88	1.52	1.25	2.58	5000-4

8010 Series Nipples



Ball Valve

See page A-2 for additional ISO 5675 tip options.

Body Size	Coupler Part Number	Port End	Valve Type	Length	Largest Diameter	Wrench Flats	Weight (lbs.)	Complete Coupling Part Number
1/2	8010-4	1/2-14 NPTF	Ball	1.95	1.23	1.06	0.20	5000-4
1/2	8010-15	3/4-16 ORB	Ball	1.95	1.23	1.06	0.20	-
1/2	8010-16	7/8-14 ORB	Ball	1.95	1.23	1.06	0.25	-

5000 Replacement Parts

1/2

O-Rings - Nitrile	50001-211-0260
-------------------	----------------

5000 Series Dust Caps and Plugs



Body Size	Dust Plugs (Coupler)	Color/Material	Dust Cap (Nipple)	Weight (lbs.)
3/8	5205-3M	Black Rubber	5209-3M	.03
1/2	5205-4M	Black Rubber	5209-4M	.04
1/2	5205-4M-BU	Blue Rubber	5209-4M-BU	.04
1/2	5205-4M-GR	Green Rubber	5209-4M-GR	.04
1/2	5205-4M-RE	Red Rubber	5209-4M-RE	.04
1/2	5205-4M-YE	Yellow Rubber	5205-4M-YE	.04
1/2	5005-4	Steel w/Chain	5009-4	.21

1/8"

1/4"

3/8"

1/2"

5/8"

3/4"

1"

1-1/4"

1-1/2"

5001-4 Single breakaway clamp

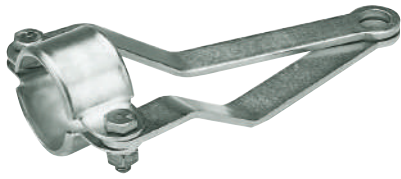

Designed for use with all Pioneer couplers having a 1-1/2" diameter sleeve (1/2" body size). Yokes and braces are heavy duty metal stampings.

5006-4 Double breakaway clamp



Designed for use with all Pioneer couplers having a 1-1/2" diameter sleeve (1/2" body size). Yokes and braces are heavy duty metal stampings.

9006-4 Double breakaway clamp



Designed for use with 9250 lever couplers. Steel material bar with heavy duty diecast yoke.



Catalog 3900 - Agricultural Quick Coupling Adapters

Pioneer adapters shown here provide the most reliable and exacting interchange in the industry.

How To Connect Using An Adapter

Step 1 Relieve trapped pressure in the implement line.

Step 2 Connect male tip on the implement line into the adapter.

Step 3 Connect the Adapter into the female body.

To Disconnect: Reverse the above procedure: first disengage adapter from female body, then male tip from adapter.



	Part Number	Adapts This Style Of Male Tip	To This Female Body
	4060-4	Pioneer Style	John Deere Old Style
	4065-4	John Deere Old Style	Pioneer Style
	4065-4L	John Deere Old Style	John Deere 50 Series Ford/ISO Pioneer 9250
	4067-4	John Deere Old Style	International Harvester Old Style
	4068-4	John Deere Old Style	J I Case Old Style
	4070-4	Pioneer Style	International Harvester Old Style
	4075-4	International Harvester Old Style	Pioneer Style
	4075-4L	International Harvester Old Style	John Deere 50 Series Ford/ISO Pioneer 9250
	4076-4	International Harvester Old Style	John Deere Old Style
	4080-4	Pioneer Style	J I Case Old Style
	4085-4	J I Case Old Style	Pioneer Style



Catalog 3900 - Agricultural Quick Coupling Adapters

To select the proper Pioneer adapter:

Locate your tractor coupler along the left vertical column. Then locate your implement nipple along the top horizontal column. Now follow these two rows inward until they intersect at the correct adapter. For example: The proper adapter to connect a tractor with a Pioneer coupler to an implement with a J.I. Case nipple would be a 4085-4.

 Male Tips  Female Bodies	John Deere 	Pioneer ISO Tip 	International Harvester 	J.I. Case (old) 
John Deere (old) 	NO ADAPTER REQUIRED	4060-4 	4076-4 	N/A
John Deere (new) 	4065-4L 	NO ADAPTER REQUIRED	4075-4L 	N/A
International Harvester (old) 	4067-4 	4070-4 	NO ADAPTER REQUIRED	N/A
J.I. Case (old) 	4068-4 	4080-4 	N/A	NO ADAPTER REQUIRED
J.I. Case (new) 	4065-4L 	NO ADAPTER REQUIRED	4075-4L 	N/A
Pioneer* 	4065-4 	NO ADAPTER REQUIRED	4075-4 	4085-4 
Parker/Pioneer 60 Series 	N/A	4069-4 	N/A	N/A

* Pioneer Couplers include: 4000, 4200, 6600, 8200, 8450, 9200, and 5000 Series



Original Equipment Products



Pioneer offers the most complete line of products in the industry.

Interchangeable Products For:

Quick Couplings



SM-502-8FP, Male Tip - replaces 4610-4. Connects with Allis-Chalmers 255018 and similar couplers. Has positive sealing poppet valve. Case hardened for wear resistance, zinc plated for corrosion protection.



5080-4, Male Tip. Connects with J I Case A28542 and similar couplers. Has positive sealing poppet valve and shielded valve retainer to prevent flow checking. Case hardened and zinc plated for long service.



8010-4P, Male Tip. Connects with Ford and similar couplers. Has positive sealing poppet valve.



*** 5060-4, Male Tip.** Fits John Deere AR47331 sleeve-type female bodies. Has durable chrome alloy precision ball valve. Induction hardened at the locking groove to minimize brinelling, and zinc plated for corrosion protection.



*** 5060-15, Male Tip.** Also fits John Deere AR47331 (See 5060-4), but has 3/4-16 O-ring boss thread.



4056-4. Connects with John Deere AR30210 and Pioneer 5060-4 male tips. Interchange for John Deere AR47331. Has a single acting sleeve and will connect only after trapped pressure has been released.



4056-15. Connects with John Deere AR30210 and Pioneer 5060-15 male tips. Inter-change for John Deere AR47331 coupler. Has single-acting sleeve.

Allis-Chalmers				
Product Description	Pioneer Part Number	O.E.M. Part Number	Port End	Rated (psi) Pressure
Allis-Chalmers Old Style Male Tip	SM-502-8FP	247336	1/2-14 NPTF	3000

J I Case				
Product Description	Pioneer Part Number	O.E.M. Part Number	Port End	Rated (psi) Pressure
J I Case Old Style Male Tip	5080-4	A160884	1/2-14 NPTF	3000

Ford				
Product Description	Pioneer Part Number	O.E.M. Part Number	Port End	Rated (psi) Pressure
Ford	8010-4P	D-3NN-B964A	1/2-14 NPTF	3000

John Deere				
Product Description	Pioneer Part Number	O.E.M. Part Number	Port End	Rated (psi) Pressure
John Deere Male Tip	5060-4	RE-11447	1/2-14 NPTF	3000
John Deere Male Tip	5060-15	AR30210 (old) AR93819 (new)	3/4-16 ORB	3000
John Deere Female Tip	4056-4	N.A.	1/2-14 NPTF	3000
John Deere Female Tip	4056-15	AR47331 (old) RE15361 (new)	3/4-16 ORB	3000



5070-4, Male Tip. Fits I-H 544788R1 and Pioneer 4057-4 female bodies. Ball style valving. Heat treated and zinc plated for resistance to wear and corrosion.



5070-16, Male Tip. Also fits I-H 544788R1 and Pioneer 4057-4 female bodies. Ball style valving, heat treated and zinc plated for resistance to wear and corrosion. 7/8 -14 O-ring boss thread.



5077-4, Male Tip. Fits I-H 395150-R1 (gold style) coupler. Positive sealing poppet valve. Heat treated and zinc plated for resistance to wear and corrosion.



5077-16, Male Tip. Also fits I-H 395150-R1 (See 5077-4), but has 7/8 -14 O-ring boss thread. Notched hex for easy identification.



4057-4, coupler. Connects with I-H 544787R91 and Pioneer 5070-4 male tips. Interchange for I-H 544788R1. Has single-acting sleeve; trapped pressure must be released to make connection. Precision ball-check valving. Zinc plated.



8010 Series Universal Male Tip. The standard male tip of the agricultural industry, Rugged, reliable ball valve and induction-hardened locking ball groove. Shielded valve plus valve stop eliminates flow checking when used with connect-under-pressure type couplers. Tapered hex design for easy identification.

International Harvester (currently Case New Holland)				
Product Description	Pioneer Part Number	O.E.M. Part Number	Port End	Rated (psi) Pressure
I H Male Tip	5070-4	B91308	1/2-14 NPTF	3000
I H Male Tip	5070-16	544787R91	7/8-14 ORB	3000
I H Male Tip	5077-4	395151R1	1/2-14 NPTF	3000
I H Male Tip	5077-16	395149R1	7/8-14 ORB	3000
I H Female Body	4057-4	544788R1	1/2-14 NPTF	3000

Other Tractor Manufacturer Specifications				
Product Description	Pioneer Part Number	O.E.M. Part Number	Port End	Rated (psi) Pressure
Massey-Ferguson Male Tip	8010-4	242678M91	1/2 NPTF	3000
Massey-Ferguson Male Tip	8010-15	1026700M91	3/4-16 O-Ring Boss	3000





Replacement Cartridge for John Deere Lever Operated Hydraulic Couplers

These replacement breakaway coupling cartridges are the next generation in Pioneer coupling technology.

All moving components are within the original hydraulic coupler casting. These castings also have self contained oil spillage, and integrated dust protection. All casting couplings provide an emergency breakaway feature as well as allowing you to connect under residual pressure.

This item is used on on the following models

John Deere: Series 7, Series 8 and Series 9 Tractors

This cartridge is equivalent to **John Deere #RE256693**.

Ordering Information

The 0510-007 replacement coupling cartridge is available in two packaging formats. You can order individually bagged, or in the Valu-Pak clamshell for retail display.



Specifications			
Body Size	Part Number	Description	Pressure Rating (psi)
1/2	0510-007	Individual Cartridge (Bagged)	3000 PSI
1/2	VP0510-007-CS	Individual Cartridge (Clamshell)	3000 PSI
1/2	0307-041	Cartridge Interface Seal Kit	N/A
1/2	0101-031	Casting Seal Kit	N/A



Replacement Cartridge for John Deere Lever Operated Hydraulic Couplers

These replacement breakaway coupling cartridges are the next generation in Pioneer coupling technology.

All moving components are within the original hydraulic coupler casting. These castings also have self contained oil spillage, and integrated dust protection. All casting couplings provide an emergency breakaway feature as well as allowing you to connect under residual pressure.

This item is used on on the following models

John Deere: Series 8 and Series 9 Tractors

This cartridge is equivalent to **John Deere #RE52981**.

Ordering Information

The 0002-076 replacement coupling cartridge is available in two packaging formats. You can order individually bagged, or in the Valu-Pak clamshell for retail display.

Specifications

Body Size	Part Number	Description	Pressure Rating (psi)
1/2	0002-076	Individual Cartridge (Bagged)	3000 PSI
1/2	VP0002-076-CS	Individual Cartridge (Clamshell)	3000 PSI
1/2	0307-041	Cartridge Interface Seal Kit	N/A
1/2	9003-091	Casting Seal Kit	N/A





Replacement Cartridge for John Deere Hydraulic Couplers

These replacement breakaway coupling cartridges are the next generation in Pioneer coupling technology.

All moving components are within the original hydraulic coupler casting. These castings also have self contained oil spillage, and integrated dust protection. All casting couplings provide an emergency breakaway feature, as well as allowing you to connect when both the tractor and the implement are under pressure.

This item is used on the following models

John Deere: Series 7 Tractors

This cartridge is equivalent to **John Deere #RE43891**.

Ordering Information

The DR10006 replacement coupling cartridge is available in two packaging formats. You can order individually bagged, or in the Valu-Pak clamshell for retail display.

Specifications			
Body Size	Part Number	Description	Pressure Rating (psi)
1/2	DR10006	Individual Cartridge (Bagged)	3000 PSI
1/2	0307-041	Cartridge Interface Seal Kit	N/A
1/2	9003-091	Casting Seal Kit	N/A

Note: This coupler connects with all Pioneer 1/2" 8010 Series ISO 5675 male tips.



Replacement Power Beyond Rigid Mount Coupler for John Deere Tractors

This product features a design that will not connect to a pressurized male tip protecting sensitive tractor components.

It can be mounted directly to the valve or rigid tubing, eliminating the need for hose assemblies and breakaway clamps.

The enclosed outer housing prevents dust and dirt build up. All moving components are internal. All rigid mount couplings provide an emergency breakaway feature.

This item is used on on the following models

John Deere: Series 7, Series 8 and Series 9 Tractors

This coupling is equivalent to John Deere #RE345116

Technical Information

Thread Port: M27 x 2 (ISO 6149)
 Overall Length: 3.88" (98.5 mm)
 Pressure Rating: 3,000 PSI (207 bar)
 Rated Flow: 19.8 GPM (75 L/min)
 Interface: Connects with Pioneer 8010 (ISO 5675) 1/2" male tips



Specifications			
Body Size	Part Number	Description	Pressure Rating (psi)
1/2	RSD-501-27MM-SSD	Rigid Mount	3000 PSI
1/2	RM5DC-01	Dust Cap	N/A





Replacement Power Beyond Rigid Mount Coupler for John Deere Tractors

This product features a design that will not connect to a pressurized male tip protecting sensitive tractor components.

It can be mounted directly to the valve or rigid tubing, eliminating the need for hose assemblies and breakaway clamps.

The enclosed outer housing prevents dust and dirt build up. All moving components are internal. All rigid mount couplings provide an emergency breakaway feature.

This item is used on on the following models

John Deere: Series 5, Series 6, Series 7, Series 8 and Series 9 Tractors

This coupling is equivalent to John Deere #RE322903 and substitutes previous parts #RE219422, #RE55859 and #RE161000

Technical Information

- Thread Port: M22 x 1.5 (ISO 6149)
- Overall Length: 4.26" (108.4 mm)
- Pressure Rating: 3,000 PSI (207 bar)
- Rated Flow: 19.8 GPM (75 L/min)
- Interface: Connects with Pioneer 8010 (ISO 5675) 1/2" male tips

Specifications

Body Size	Part Number	Description	Pressure Rating (psi)
1/2	RSD-501-22MM-SSD	Rigid Mount	3000 PSI
1/2	RM5DC-01	Dust Cap	N/A



Replacement Rigid Mount Coupler for John Deere, Massey-Ferguson and Challenger Tractors

This product features a design that permits connection while the implement is under pressure.

It can be mounted directly to the valve or rigid tubing, eliminating the need for hose assemblies and breakaway clamps.

The enclosed outer housing prevents dust and dirt build up. All moving components are internal. All rigid mount couplings provide an emergency breakaway feature.

This item is used on on the following models

John Deere: Series 5, Series 6 and Series 7 Tractors

This coupling is equivalent to John Deere #AL200979 and substitutes previous part #AL166181

Massey-Ferguson: 2000 and 5000 Series Tractors

Challenger: MT4 and MT5 Series Tractors

This coupling is equivalent to Massey-Ferguson/Challenger 3905722M91

Technical Information

Thread Port: M22 x 1.5 (ISO 6149)

Overall Length: 4.54" (115.3 mm)

Pressure Rating: 3,000 PSI (207 bar)

Rated Flow: 19.8 GPM (75 L/min)

Interface: Connects with Pioneer 8010 (ISO 5675) 1/2" male tips



Specifications

Body Size	Part Number	Description	Pressure Rating (psi)
1/2	RSD-501-22MM-L103	Rigid Mount	3000 PSI
1/2	RM5DC-01	Dust Cap	N/A





Replacement Rigid Mount Coupler for John Deere Tractors

This product features a design that permits connection while the implement is under pressure.

It can be mounted directly to the valve or rigid tubing, eliminating the need for hose assemblies and breakaway clamps.

The enclosed outer housing prevents dust and dirt build up. All moving components are internal. All rigid mount couplings provide an emergency breakaway feature.

This item is used on on the following models

John Deere: Series 5, Series 6 and Series 7 Tractors

This coupling is equivalent to John Deere #SJ11129 and substitutes previous part #RE219420 and #SJ30426

Technical Information

Thread Port: 13/16-16UN O-Ring Face Seal
 Overall Length: 4.28" (108.6 mm)
 Pressure Rating: 3,000 PSI (207 bar)
 Rated Flow: 19.8 GPM (75 L/min)
 Interface: Connects with Pioneer 8010 (ISO 5675) 1/2" male tips

Specifications

Body Size	Part Number	Description	Pressure Rating (psi)
1/2	RSD-501-8MS	Rigid Mount	3000 PSI
1/2	RM5DC-01	Dust Cap	N/A



Non-Spill Breakaway Coupling Helps Reduce Hydraulic Motor Seal Failures



The FRM-371-22MM-1146 (Formerly 0309-131) non spill coupler features flush face valving and is designed for use on case drain lines, which are required on air seeder applications. This coupling's unique interface prevents standard Pioneer ISO male tips from being connected in error.

This rigid mount coupler features a breakaway mechanism that will separate when a 45 lbs. linear force is applied, or when pressures in the case drain line exceeds 200 PSI.

When used in conjunction with Pioneer male tip 0303-050, it provides double protection against damage to hydraulic components.

This item is used on on the following models

John Deere: Series 5, Series 6 and Series 7, Series 8 and Series 9 Tractors

This item is equivalent to **John Deere #TA19919** and substitutes previous part **#RE584722** and **#RE222718**

Ordering Information

The FRM-371-22MM-1146 is available in standard distributor packaging of 10 pieces, or individually in the VP clam shell pack

* Note: Do not use the Pioneer FEM-372 in this application

The special 0303-050 pressure relieving male tip can be used on air seeders of any makes to prevent motor seal damage. Please contact Pioneer if you have questions about your application or the components used on a specific tractor make or model.

Specifications			
Body Size	Part Number	Description	Pressure Rating (psi)
3/8"	FRM-371-22MM-1146	Distributor Pack (10 per box)	100 PSI
3/8"	VPFRM-371-22MM-1146-CS	Individual Male Tip (Clamshell)	100 PSI





Self Relieving Tip Reduces Hydraulic Motor Seal Failures

Although this male tip looks very similar to the standard 3/8" FF or FEM series coupling products, it features one of the most unique designs to be released from engineering.

The air seeder market was facing challenges of hydraulic motor seals failing due to thermal expansion and improperly connected case drain lines. In the event that an end user forgets to connect this coupling to a return-to-tank line, the poppet valve opens at 10 psi and vents trapped oil to atmosphere. This prevents the motor seal from failing, avoiding costly downtime situations during planting season.

This item is used on the following models

John Deere: Planters, Air Seeders, Series 6, Series 7 and Series 9 Tractors

This item is equivalent to **John Deere #AA59671**.

Ordering Information

The 0303-050 is available in standard distributor packaging of 10 pieces, or individually in the VP clam shell pack.

Note: Do not use the standard Pioneer FF-372-* or FEM-372-* products in this application.

This pressure relieving tip can also be used on air seeders of any make to prevent motor seal damage. Please contact Pioneer if you have questions about your application or the coupler used on a specific tractor make or model.

Specifications

Body Size	Part Number	Description	Pressure Rating (psi)
3/8	0303-050	Distributor Pack (10 per box)	3000 PSI
3/8	VP0303-050-CS	Individual Male Tip (Clamshell)	3000 PSI



Prevent Reverse Flow rom Damaging Hydraulic Motors and Equipment



This specially designed ISO-5675 (ISO 7241-1, Series A) male tip connects with OEM tractor motor return couplers and hydraulic circuits. Please consult the owners manual for your tractor or equipment before installing this product. Failure to connect to a proper port could lead to damaged equipment. Motor return ports (sometimes labeled with an "R") and case drain lines are different, so make sure this product is plumbed correctly.

This product is used on the motor return line of the circuit. An internal check valve prevents reverse flow and damage to hydraulic motors and equipment. This tip will also vent to atmosphere if pressure exceeds 15 psid to prevent hydraulic motor seal damage when disconnected.

This item is commonly used on air seeders, drills and planters, but it is also found on other hydraulic circuits or applications.

This male tip has a 3/4"-16 ORB (-8) thread and is rated to 30 gpm.

This item is used on the following models

John Deere: Multiple Planters, Air Seeders and Implements

This item is equivalent to **John Deere #AA59411**

Ordering Information

The 0304-170 is available in a distributor pack of 50 pieces, or individually in the VP clam shell package.

Note: This part will vent fluid to atmosphere if pressure in the line exceeds 15 psid when disconnected. This is a function of this product. Do not attempt to stop flow with your hand! Hydraulic fluid injection is very dangerous. Seek immediate medical attention if injected.

Specifications

Body Size	Part Number	Description	Pressure Rating (psi)
1/2	0304-170	Distributor Pack (50 per box)	3000 PSI





Repair and Replace Individual Components on the John Deere® Combine Single Point Multi-Couplings

Parker is the market leader in this multi-coupling design, and revolutionized the single point connection on implement and harvesting equipment.

- Direct identical replacement for OEM equipment
- Cartridges to service both the header and combine coupling sides
- Available in 3/8" and 1/2" body size

Ordering Information

Specifications		
Part Number	Description	OEM Number
0004-042	Header - 3/8" Coupling	AH225668
0004-044	Header - 1/2" Coupling	AH225669
0003-110	Combine - 3/8" Coupling	AH225670
0003-093	Combine - 1/2" Coupling	AH225671
0006-052	All Function Header Coupling	AH166991
0006-052-20	Reel Fore & Reel Aft, Corn Header Plate Adj.	AH166993
0509-037	Dust Plug Inserts	H206826
50023-125-2010	Retaining Rings for 0004-042 & 0004-044	H178181
0101-064	Service Tool for Combine Couplings	AH201808
0004-042-KITS	3/8 Seal Kit for 0004-042	AH225672
0004-044-KITS	1/2" Seal Kit for 0004-044	AH225673



ISO 5675 Universal Male Tip for John Deere Equipment



The DR10008 male tip is manufactured to meet the original John Deere dimensional specifications, and has a slightly smaller hex size than a standard Pioneer tip.

- Meets all ISO 5675 dimensional specifications
- Induction hardened ball locking groove to prevent brinelling and increase life
- Shielded valve and valve stop eliminates flow checking
- Leak-free poppet valve design
- Protective zinc plating with clear trivalent chromate finish

This item is used on the following models

John Deere: Multiple Tractors, Harvesters, Planters and Combines

This male tip is equivalent to **John Deere AR94522**.

Ordering Information

The DR10008 is available in two packaging formats. Available in bulk packages of 25, or individually in the Valu-Pak clam shell.

Specifications

Body Size	Part Number	Thread	Pressure Rating (psi)
1/2"	DR10008	3/4-16 Female ORB	3000 PSI





Replacement Coupler for John Deere Lawn & Turf Equipment

The 4050-2P-T8M coupler is a durable proven design in the lawn and turf market. This coupler features a poppet valve that provides a 'bubble tight' seal when disconnected.

The accessory hydraulic circuits on this equipment are commonly used for snow blowers, loaders, blades, rotary brooms, and other 3-point attachments.

This item is used on the following models

John Deere: X500, X700 and X900 Series Lawn and Garden Tractor Attachments

This coupling is equivalent to **John Deere #AM115139**.

Note: This product may also be used on additional models.

Ordering Information

Specifications			
Body Size	Part Number	Description	Pressure Rating (psi)
1/4	4050-2P-T8M	1/4" Pioneer Coupler with a Male 3/4-16UNF Thread	3000 PSI

Note: This coupler connects with Pioneer part numbers 4010-2P or 4010-T6.



Eliminate the Need for Adapters for Your 4000 Series John Deere Tractors

The Pioneer DR10010 cartridge conversion kit is designed to convert John Deere 4000 Series tractors for use with ISO 5675 Pioneer style tips.

Upgrading your tractor with this conversion kit will eliminate the need for adapters. You will no longer need to adapt implements using the ISO male tips to the old style John Deere coupling interface.

- Easy push/pull operation
- Reduced pressure drop for longer system life
- Simple and fast installation
- Protective zinc plating with clear trivalent chromate finish

This item is used on the following models

This kit is equivalent to **John Deere RE206778**.

Ordering Information

This kit contains the components to convert two original John Deere couplings. (All of the components pictured above are included in the kit.)



Specifications			
Body Size	Part Number	Thread	Pressure Rating (psi)
1/2	DR10010	Kit	3000 PSI





Replacement Cartridge for Case I-H Hydraulic Couplers

These replacement breakaway coupling cartridges are the next generation in Pioneer coupling technology.

All moving components are within the original OEM hydraulic coupler casting. These castings also have self contained oil spillage, and integrated dust protection. All casting couplings provide an emergency breakaway feature as well as allowing you to connect under residual pressure.

This item is used on on the following models

CNH: Magnum and Quadtrac Steiger Tractors

This coupling is equivalent to Case I-H #84262367 and substitutes previous parts #86026209, #275182A1, #275182A2, #321623A1, #321623A2, #47881535, #87773784, #87775632, #87776294, #93328C1, #93328C2, #93328C3, #719646016 and #719648016

Ordering Information

The Pioneer CH20001 replacement coupling cartridge is available in two packaging formats. You can order individually bagged, or in the Valu-Pak clamshell for retail display.

Specifications

Body Size	Part Number	Description	Pressure Rating (psi)
1/2	CH20001	Individual Cartridge (Bagged)	3000 PSI
1/2	0307-041	Cartridge Interface Seal Kit	N/A
1/2	9003-091	Casting Seal Kit	N/A
1/2	8503-059*	Square Wire Spring	N/A
1/2	8503-060*	Retraining Ring	N/A

* Note: These items are only required if damaged or lost.





Replacement Rigid Mount Coupler for Case I-H Tractors

This product features a design that permits connection while both the tractor and implement are under pressure.

They can be mounted directly to a valve or rigid tubing, eliminating the need for hose assemblies and breakaway clamps. These are a push-to-connect and pull-to-disconnect design.

The enclosed outer housing prevents dust and dirt build up. All moving components are internal. All rigid mount couplings provide an emergency breakaway feature, as well as allowing you to connect under residual pressure.

This item is used on on the following models

CNH: Magnum Tractors

This coupling is equivalent to **Case I-H #195315A2**

Technical Information

Thread Port: M22 x 1.5 Male (ISO 6149-2)

Overall Length: 4.11" (104.4 mm)

Pressure Rating: 3,000 PSI (Connect under pressure to 3,000 PSI)

Rated Flow: 33 GPM

Interface: Connects with Pioneer 8010 (ISO 5675) 1/2" male tips

Specifications			
Body Size	Part Number	Description	Pressure Rating (psi)
1/2	CH20005	Individual Cartridge (Bagged)	3000 PSI
1/2	0307-031	Repair Kit with Instructions	N/A
1/2	8512-030	Dust Cap	N/A

Ordering Information

The Pioneer CH20005 replacement coupler is available in two packaging formats. You can order in the standard box quantity, or in the Valu-Pak clamshell for retail display.



Replacement Power Beyond Rigid Mount Coupler for Case I-H Tractors

It can be mounted directly to the valve or rigid tubing, eliminating the need for hose assemblies and breakaway clamps.

The enclosed outer housing prevents dust and dirt build up. All moving components are internal. All rigid mount couplings provide an emergency breakaway feature.

This item is used on on the following models

CNH: Magnum and Quadtrac Steiger Tractors

This coupling is equivalent to Case I-H #298291A1

Technical Information

Thread Port: M27 x 2 (ISO 6149)
 Overall Length: 3.95" (100.3 mm)
 Pressure Rating: 2900 PSI (200 bar)
 Rated Flow: 28.0 GPM (106 L/min)
 Interface: Connects with ISO 7241-1, Series A Pioneer 6600 3/4" male tips

Specifications

Body Size	Part Number	Description	Pressure Rating (psi)
3/4	9712-015	Rigid Mount	2900 PSI
3/4	9804-038	Dust Cap	N/A



State-of-the-Art Coupler Features Rigid Mounting and Connect/Disconnect Under Pressure



The Pioneer 0312-001 rigid mount coupler features a patented design that permits connection while both the coupler and male tip are under pressure.

These couplers can be mounted directly to a valve or rigid tubing, eliminating the need for hose assemblies and break-away clamps.

- Easy push/pull connection and disconnection under system pressure
- Enclosed outer housing prevents dust and dirt build up
- This coupler accepts all Pioneer 8010 Series or ISO 5675 male tips
- Protective zinc plating with clear trivalent chromate finish

This item is used on the following models

Kubota: L Series Tractor Loader Backhoe

This coupling is equivalent to **Kubota 3A111-82011**.

Ordering Information

The 0312-001 is available in two packaging formats. Available in packages of five, or individually in the Valu-Pak clam shell for retail displays.

Specifications			
Body Size	Part Number	Thread	Pressure Rating (psi)
1/2	0312-001	7/8-14UNF-2B	3000 PSI
1/2	VP0312-001-CS	7/8-14UNF-2B	3000 PSI





8500-4 Century II Break-Away Kit

Contains 8200 Series couplings and accessories.

For connections having pressure on either tractor side or implement lines, or both.

8500-4 kit contains:

- (2) 8250-4 female bodies
- (2) 5205-4M dust plugs
- (2) 8010-4 male tips
- (2) 5209-4M dust caps
- (1) 5006-4 clamp



8700 Series ISO Conversion Kit

Upgrade International Harvester tractors to accept ISO male tips models 1971 to 1983.

- Converts lever style tractors to accept ISO interchange male tips
- Easy push/pull connect and disconnection
- Reduced pressure drop – longer system life
- Simple, fast installation
- Dust cap keeps dust and dirt out



9500-4 Lever Break-Away Kit

Contains 9200 Series couplers and accessories.

For connect and disconnect at zero pressure, even with pressurized lines.

9500-4 kit contains:

- (2) 9250 female bodies
- (1) 9507-4-1H automatic dust cover
- (1) 9006-4 double breakaway clamp



NEW 9502-4 Kit

Contains fully assembled 9200 Series couplers with accessories in retail friendly packaging.

For connect and disconnect at zero pressure, even with pressurized lines.

9502-4.1.1 kit contains:

- (2) 9250 female bodies
- (1) 9507-4-1H automatic dust cover
- (1) 9006-4 double breakaway clamp



Pioneer’s Merchandising Boxes provide an effective point of purchase display for our products. Pioneer’s most common products are shipped and displayed in the same convenient packaging. Simply fold the top of the box and you have an instant display card – complete with product description and part number.

Male Tips		
8010-4MB	1/2" Male Tip 1/2" NPTF	10
8010-4PMB	1/2" Male Tip (Poppet Valve) 1/2" NPTF	10
5060-4MB	1/2" John Deere Male Tip 1/2" NPTF	10
Quick Coupling Adapters		
4060-4MB	Pioneer Male Tip to John Deere Female Body	5
Female Quick Couplers		
4050-4MB	1/2" Female Body 1/2" NPTF	5
4250-4MB	1/2" Female Body 1/2" NPTF	5
8250-4MB	1/2" Female Body 1/2" NPTF	5
Quick Coupling Sets		
4000-4MB	1/2" Complete Coupling 1/2" NPTF	5
4200-4MB	1/2" Complete Coupling 1/2" NPTF	5



Dimensions:
22 1/2" x 26 3/4" x 14"
Products not included



**K404-EX Overhead Extension
Color Coded
Dust Caps and Plugs**
Products not included

Color coded dust caps and plugs are perfect for preventing mismatched connections. They also prevent contamination and protect couplers and nipples from damage. Simply match the color to the original equipment manufacturer.

Maximize Your Profits and Increase Sales

For nearly 20 years the K404 gravity feed display has been a favorite marketing tool for the Pioneer retail segment, allowing you to maximize profits from a minimal amount of space.

As the hydraulic market continues to evolve, so do the coupling requirements of the agricultural customer. This attractive full color merchandising display will put today's most popular coupling products in front of your customer.

The new colorful decal will assist you in making the correct product choice for your customer's application.

Gravity Feed Counter Display Features:

- Thirteen merchandise slots for increased visibility of Pioneer's most active and profitable products
- Full color laminated decal with specifications, photos and the features and benefits of each product.
- Expandable to include the K404-EX color coded dust caps and plugs for maintaining proper connections.
- Expanded product offering that includes the popular FEM Series skid loader couplings.



K404 Gravity Feed Display
Products not included

This time proven sales tool will help you maximize your profits from counter sales. This is a great opportunity to put a product in your customer's hand. Quality and durability make these products 'The Farmers Choice'.

Gravity Display and Accessories

Part No.	Description	Qty
K404	Gravity Display Wire Rack	1
K404-DECAL	Decal	1
K404-EX	Overhead Extension	1

Parts for Overhead Extension (K404-EX) - Order Separately

Part No.	Color	Description	Qty
5205-4M	Black	Dust Plug	16
5209-4M	Black	Dust Cap	16
5205-4M-BU	Blue	Dust Plug	8
5209-4M-BU	Blue	Dust Cap	8
5205-4M-GR	Green	Dust Plug	16
5209-4M-GR	Green	Dust Cap	16
5205-4M-RE	Red	Dust Plug	8
5209-4M-RE	Red	Dust Cap	8
5205-4M-YE	Yellow	Dust Plug	8
5209-4M-YE	Yellow	Dust Cap	8

Parts for Display (K404) - Order Separately

Part No.	Description	Qty
8010-4	ISO Tip, 1/2" NPT, Ball Valve	10
8010-4P	ISO Tip, 1/2" NPT, Poppet Valve	10
8010-4P-DC	ISO Tip, 1/2" NPT, Pressure Release	10
DR10008	John Deere Style ISO Tip	10
5060-4	John Deere Old Style Tip, 1/2" NPT	10
5060-15	John Deere Old Style Tip, 3/4" ORB	10
4050-4	ISO Coupler, Single Acting Sleeve	5
4250-4	ISO Coupler, Double Acting Sleeve	5
8250-4	ISO Coupler, Connect-Under-Pressure	5
FEM-501-8FP-NL	Skid Steer/Construction Coupler, 1/2" NPT	5
FEM-502-8FP	Skid Steer/Construction Nipple, 1/2" NPT	5
4060-4	Pioneer to John Deere Old Style Adapter	5
4065-4	John Deere Old Style to Pioneer Adapter	5

Packaging That's Better Than Ever

Look at these advantages:

- Valu-Pak is compact – takes less room. Hangs easily from peg board.
- Clear blister-pac reveals enclosed product and protects it from dust, dirt and thread damage.
- Valu-Pak is environmentally friendly. Package is reusable and recyclable.
- Products displayed in Valu-Pak provide a well organized stock, better inventory control and less opportunity for theft.
- Package includes product part number, description, and bar code.



For the latest list of all available Valu-Pak products, please consult the Pioneer Price List.

IS05675 Male Tips		
Part No.	Description	Port Size
VP8010-4-CS	1/2" Male Ball Tip	1/2" NPTF
VP8010-4P-CS	1/2" Male Poppet Tip	1/2" NPTF
VP8010-4P-DC-CS	1/2" Male Decompression Poppet Tip	1/2" NPTF
VP8010-15-CS	1/2" Male Ball Tip	3/4" ORB
VP8010-15P-DC-CS	1/2" Male Decompression Poppet Tip	3/4" ORB
VP4110-5-CS	3/4" Male Ball Tip	3/4" NPTF
VP4010-6P-CS	1" Male Poppet Tip	1-11 1/2" NPTF
VP5209-4M-CS	1/2" Black Dust Cap for Tip (package of 2)	N/A
VP5209-4M-GR-CS	1/2" Green Dust Cap for Tip (package of 2)	N/A
VP5209-4M-RE-CS	1/2" Red Dust Cap for Tip (package of 2)	N/A
VP5209-4M-BU-CS	1/2" Blue Dust Cap for Tip (package of 2)	N/A
VP5209-4M-YE-CS	1/2" Yellow Dust Cap for Tip (package of 2)	N/A
IS05675 Female Couplers		
VP4050-4-CS	1/2" Female Ball Coupler	1/2" NPTF
VP4050-4P-CS	1/2" Female Poppet Coupler	1/2" NPTF
VP4250-4-CS	1/2" Female Ball Coupler	1/2" NPTF
VP4250-4P-CS	1/2" Female Poppet Coupler	1/2" NPTF
VP8250-4-CS	1/2" Female Ball Coupler	1/2" NPTF
VP5050-4-CS	1/2" Female Ball Coupler Connect Under Pressure	1/2" NPTF
VP4150-5-CS	3/4" Female Ball Coupler	3/4" NPTF
VP4050-6P-CS	1" Female Poppet Coupler	1-11 1/2" NPTF
VP2-211N0552-90-CS	1/2" Interface O-Rings for 1/2" ISO5675 Couplers (5 pack)	N/A
VP5205-4M-CS	1/2" Black Dust Plug for Coupler (package of 2)	N/A
VP5205-4M-GR-CS	1/2" Green Dust Plug for Coupler (package of 2)	N/A
VP5205-4M-RE-CS	1/2" Red Dust Plug for Coupler (package of 2)	N/A
VP5205-4M-BU-CS	1/2" Blue Dust Plug for Coupler (package of 2)	N/A
VP5205-4M-YE-CS	1/2" Yellow Dust Plug for Coupler (package of 2)	N/A
5006-4	1/2" Breakaway Clamp for 4200 & 8200 Series Couplers	N/A
IS05675 Quick Coupling Sets		
VP4000-2P-CS	1/4" Complete Poppet Coupling Set	1/4" NPTF
VP4000-3P-CS	3/8" Complete Poppet Coupling Set	3/8" NPTF
VP4000-4-CS	1/2" Complete Ball Coupling Set	1/2" NPTF
VP4000-4P-CS	1/2" Complete Poppet Coupling Set	1/2" NPTF
VP4000-5P-CS	1/2" Complete Ball Poppet Coupling Set	3/4" NPTF
VP4200-4-CS	1/2" Complete Ball Coupling Set	1/2" NPTF
VP4200-4P-CS	1/2" Complete Poppet Coupling Set	1/2" NPTF
VP5000-4-CS	1/2" Complete Ball Coupling Connect Under Pressure Set	1/2" NPTF
VP8200-4-CS	1/2" Complete Ball Poppet Coupling Set	1/2" NPTF



ISO 16028 Flat Face Quick Couplings

Part No.	Description	Port Size
VPFEM-501-10FO-NL-CS	1/2" Female Non-Spill Coupler	7/8" ORB
VPFEM-501-8FP-NL-CS	1/2" Female Non-Spill Coupler	1/2" NPT
VPFEM-501-12FO-NL-CS	1/2" Female Non-Spill Coupler	1-1/16" ORB
VPFEM-502-10FO-CS	1/2" Male Non-Spill Tip	7/8" ORB
VPFEM-502-8FP-CS	1/2" Male Non-Spill Tip	1/2" NPT
VPFEM-502-12FO-CS	1/2" Male Non-Spill Tip	1-1/16" ORB

Quick Coupling Adapters

Part No.	Description	Port Size
VP4060-4-CS	1/2" Pioneer Male Tip to John Deere Female Coupler	N/A
VP4065-4-CS	1/2" John Deere Male Tip to Pioneer Female Coupler	N/A
VP4070-4-CS	1/2" Pioneer Male Tip to Inter. Harvester Female Coupler	N/A

Pioneer OEM Specials

Part No.	Description	Port Size
VPFRM-371-22MM-1146-CS	3/8" John Deere Female Non-Spill Coupler #TA19919	M22x1.5
VP0002-076-CS	1/2" John Deere Female Cartridge #RE52981	N/A
VP0510-007-CS	1/2" John Deere Female Cartridge #RE577560	N/A
VP5060-4-CS	1/2" John Deere Male Ball Tip #RE11447	1/2" NPT
VP5060-15-CS	1/2" John Deere Male Ball Tip #AR93819/AR30210	3/4" ORB
VP0303-050-CS	1/2" John Deere Non-Spill Male Tip #AA59671	3/4" ORB
VPCH20001-CS	1/2" Case-IH Female Cartridge #86026209	N/A
VP5070-4-CS	1/2" Case-IH Male Ball Tip #544788R1	1/2" NPT
VP0312-001-CS	1/2" Kubota Female Rigid Mount Coupler #3A111-82011	3/4" ORB
VP3000-3-CS	3/8" Complete Coupling Screw to Connect Set for Hose Crimpers	3/8" NPTF

*For the latest list of all available Valu-Pak products, please consult the Pioneer Price List.



The 3000 Series coupling are designed for high pressure applications. The coupler sleeve and nipple body must be manually threaded together to make the connection.

Features:

- Manual threaded connection and actuation
- Hard, chrome alloy ball valves
- Polyurethane interface seal resists high pressure extrusion
- Threaded retainer provides a positive valve stop
- Protective zinc plating with clear trivalent chromate finish

Applications include:

- Hydraulic rams
- Portable hydraulic tools
- Crimping equipment

3000 Series Specifications						
Body Size	Rated Flow (gpm)	Rated Pressure (psi)	Temperature	Body Material	Sleeve Type	Seal Material
1/4	3	10,000	-22° F to +230° F	Steel	Thread to connect	Polyurethane
3/8	6			Steel	Thread to connect	Polyurethane

Performance:

3000 Series (1/4", 3/8")
Test Fluid: Oil - 200 SUS

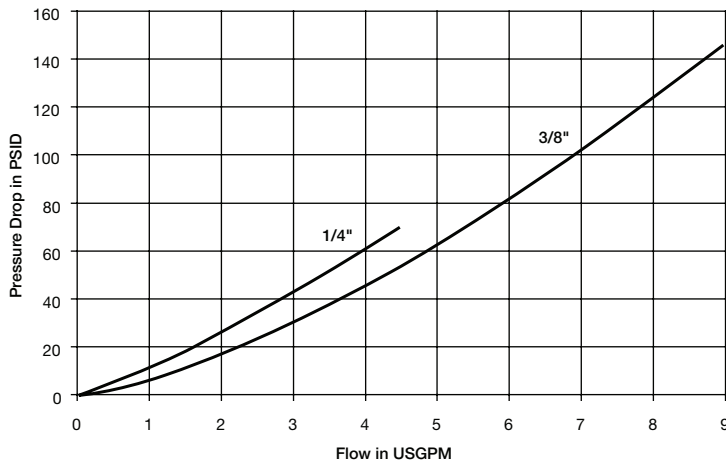



3000 Series Couplers



Body Size	Coupler Part Number	Port End	Valve Type	Length	Largest Diameter	Wrench Flats	Weight (lbs.)
1/4	3050-2	1/4-18 NPTF (Male)	Ball	2.38	1.13	0.81	0.25
3/8	3050-3	3/8-18 NPTF (Male)	Ball	2.38	1.38	1.00	0.49
3/8	3050-3-231	3/8-18 NPTF (Female)	Ball	2.38	1.38	1.00	0.49

3000 Series Nipples



Body Size	Coupler Part Number	Port End	Valve Type	Length	Largest Diameter	Wrench Flats	Weight (lbs.)
1/4	3010-2	1/4-18 NPTF (Female)	Ball	1.29	1.13	0.88	0.14
3/8	3010-3	3/8-18 NPTF (Female)	Ball	1.58	1.25	0.94	0.23
3/8	3010-3-230	3/8-18 NPTF (Male)	Ball	2.31	1.25	1.00	0.30

3000 Series Replacement O-Rings

Body Size	Material	Part Number	Durometer
1/4	Polyurethane	50001-114-0296	90
3/8	Polyurethane	50001-210-0296	90

3000 Series Dust Caps and Plugs



Body Size	Dust Cap (Nipple)	Color/Material	Dust Plug (Coupler)	Weight (lbs.)
1/4	3009-2	Steel	3005-2	.02
3/8	3009-3	Steel	3005-3	.04





FF Series couplings eliminate spillage and air inclusion when connecting and disconnecting. The sleeve locking mechanism prevents accidental disconnection. 3/8" body size complies with Hydraulic Tool Manufacturers Association standards. FC nipples provide a connect-under-pressure option for trapped pressures up to 3000 psi on the nipple side.

Features

- Flush, non-spill valving
- Hardened steel sleeves and nipple bodies
- Locking sleeve
- Sleeve-Lok design now standard
- Blow-out resistant seal
- Connect-under-pressure FC nipple option
- Standard zinc plating

Applications include:

- Hydraulic tools
- Mobile equipment
- Industrial hydraulics

Performance

FF Series (1/4", 3/8", 1/2")
Test Fluid: Oil - 200 SUS

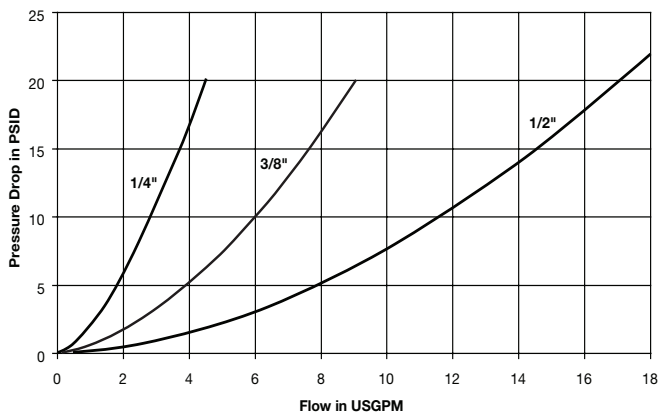

FF Series (3/4" & 1")
Test Fluid: Oil - 200 SUS

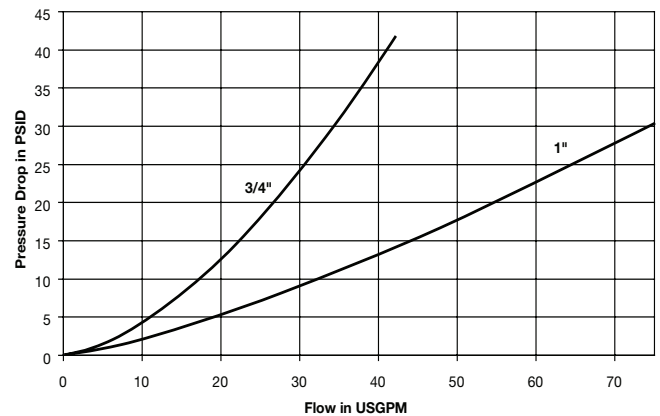

FF Series Specifications

Body Size	Rated Pressure (psi)	Rated Flow (gpm)	Temperature Range	Spillage (ml) max. per disconnect	Air Inclusion (ml) max. per connect	Body Material	Sleeve Type	Seal Material
1/4	5000	3	-40° to +250°F	.015	.020	Steel	Push to Connect	Nitrile/ Polyurethane
3/8	5000	6		.015	.020			
1/2	3000	12		.080	.070			
3/4	3000	28		.150	.100			
1	3000	50		.200	.150			





FF Series Couplers

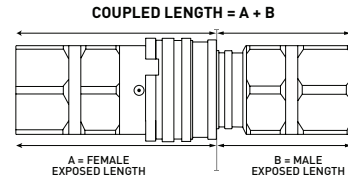

Body Size	Coupler Part Number	Port End	Length	Coupled Length	Largest Diameter	Wrench Flats	Weight (lbs.)
1/4	FF-251-4FP	1/4-18 NPSF	1.79		1.06	25 mm	0.23
1/4	FF-251-4MP	1/4-18 NPTF	1.84		1.06	25 mm	0.24
1/4	FF-251-6FO	9/16-18 UNF	1.91		1.06	25 mm	0.23
3/8	FEM-371-6FP	3/8-18 NPTF	3.06	5.02	1.26	30 mm	0.77
3/8	FEM-371-8FP	1/2-14 NPTF	3.17	5.23	1.26	30 mm	0.75
3/8	FEM-371-6FB	3/8-19 BSPP	3.06	5.02	1.31	30 mm	0.75
3/8	FEM-371-8FB	G1/2 BSPP	3.17	5.23	1.31	30 mm	0.75
3/8	FEM-371-8FO	3/4-16 UNF	3.06	5.02	1.26	30 mm	0.74
1/2	FF-501-8FP	1/2-14 NPSF	3.25		1.53	36 mm	1.18
1/2	FF-501-10FO	7/8-14 UNF	3.07		1.53	36 mm	1.075
3/4	FF-751-12FP	3/4-14 NPSF	3.50		1.94	45 mm	1.84
3/4	FF-751-12FO	1 1/16-12 UNF	3.75		1.94	45 mm	1.93
1	FF-1001-16FP	1-11 1/2NPSF	4.14		2.25	48 mm	2.64
1	FF-1001-16FO	1 5/16-12UNF	4.24		2.25	48 mm	2.68

FF Series Nipples

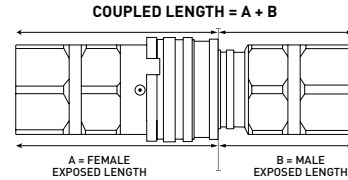

Body Size	Nipple Part Number	Port End	Length	Coupled Length	Exposed Length*	Largest Diameter	Wrench Flats	Weight (lbs.)
1/4	FF-252-4FP	1/4-18 NPSF	1.66		1.15	1.06	25 mm	0.16
1/4	FF-252-4MP	1/4-18 NPTF	1.72		1.18	1.06	25 mm	0.26
1/4	FF-252-6FO	9/16-18 UNF	1.66		1.15	1.06	25 mm	0.16
3/8	FEM-372-6FP	3/8-18 NPTF	2.59	5.02		1.26	30 mm	0.48
3/8	FEM-372-8FP	1/2-14 NPSF	2.69	5.23		1.26	30 mm	0.48
3/8	FEM-372-6FB	3/8-19 BSPP	2.59	5.02		1.26	30 mm	0.48
3/8	FEM-372-8FB	G1/2 BSPP	2.69	5.22		1.26	30 mm	0.47
3/8	FEM-372-8FO	3/4-16 UNF	2.59	5.02		1.26	30 mm	0.45
1/2	FF-502-8FP	1/2-14 NPSF	3.13		2.11	1.57	36 mm	0.87
1/2	FF-502-10FO	7/8-14 UNF	2.95		2.07	1.57	36 mm	0.77
3/4	FF-752-12FP	3/4-14 NPSF	3.38		2.47	1.73	45 mm	1.00
3/4	FF-752-12FO	1 1/16-12 UNF	3.58		2.47	1.73	45 mm	1.02
1	FF-1002-16FP	1-11 1/2 NPSF	3.85		2.60	2.17	48 mm	1.60
1	FF-1002-16FO	1 5/16-12UNF	3.85		2.60	2.17	48 mm	1.70

Standard Port Configurations: **FP** - Female Pipe Thread **FO** - Female Straight Thread
MP - Male Pipe Thread **FB** - Female British Standard Pipe Parallel

* This dimension represents the portion of the nipple that is exposed when the nipple and coupler are connected.



Optional Seal Materials:

(add code to part number)

Code	Description	Part Number Example
suffix -E5	Ethylene Propylene seal material (EPR)	FF-501-8FP-E5
suffix -E4	Fluorocarbon seal material	FF-501-8FP-E4

Optional seals include O-ring & Back-Up Ring, not Anti-Blow Out bonded seal. Contact QCD for availability and additional options. To select proper seal materials, see Fluid Compatibility Chart or contact QCD.

FF Series Repair Kits

1/4" Nipple	FF-252-KIT	FF-252-KIT-E4	FF-252-KIT-E5
3/8" Nipple	FF-372-KIT	FF-372-KIT-E4	FF-372-KIT-E5
1/2" Nipple	FF-502-KIT	FF-502-KIT-E4	FF-502-KIT-E5
3/4" Nipple	FF-752-KIT	FF-752-KIT-E4	FF-752-KIT-E5
1" Nipple	FF-1002-KIT	FF-1002-KIT-E4	FF-1002-KIT-E5

Dust Caps - FF Series

	Body Size	Coupler Dust Cap - Rubber	Nipple Dust Cap - Rubber
	1/4	FR-25	FR-25
3/8	NR-50	NR-37	
1/2	FR-501	FR-502	
3/4	FR-751	FR-752	
1	FR-1001	FR-1002	





Connect Under Pressure Operation

FC Series products operate slightly different from traditional non-spill couplings. With no pressure in the coupler and up to 3000 PSI of trapped pressure in the nipple, begin to couple the mating halves. Delay momentarily during connection to allow trapped pressure to equalize with the mating half before completing the connection.

FC Series nipples provide a connect-under-pressure option for trapped pressures up to 3000 psi on the nipple side.

Features:

- Connect-under-pressure nipple
- Flush, non-spill valving
- Hardened locking surface
- Blow-out resistant seal
- Protective zinc plating with clear trivalent chromate finish

Applications include:

- Hydraulic tools

FC Series Specifications

Body Size	Rated Pressure (psi)	Rated Connect-Under-Pressure Capability	Rated Flow (gpm)	Spillage (ml) max. per disconnect	Air Inclusion (ml) max. per connect
3/8	3000	3000	6	.015	.020
1/2	3000	3000	12	.020	.070
3/4	3000	1500	26	.150	.100

Performance

FC Series (3/8", 1/2", 3/4")
Test Fluid: Oil - 200 SUS

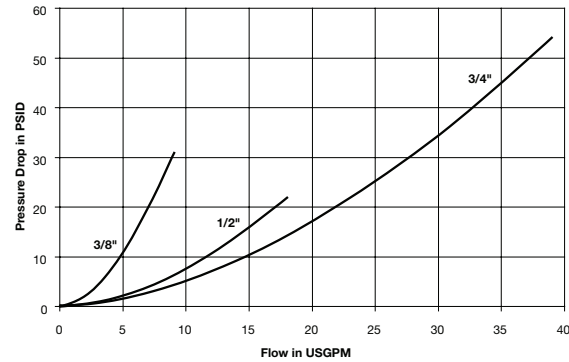

FC Series Connect Under Pressure Nipples



Body Size	Part Number	Mating Half	Port End	Length	Exposed Length*	Largest Diameter	Wrench Flats	Weight (lbs.)
3/8	FC-372-6FP	FF-371	3/8-18 NPSF	3.30	2.58	1.16	1.062	0.45
3/8	FC-372-8FO	FF-371	3/4-16 UNF	3.30	2.58	1.16	1.062	0.42
3/8	FC-372-8FP	FF-371	1/2-14 NPSF	3.30	2.58	1.16	1.062	0.42
1/2	FC-502-8FP	FF-501	1/2-14 NPSF	3.46	2.65	1.22	1.125	0.53
1/2	FC-502-10FO	FF-501	7/8-14 UNF	3.46	2.65	1.22	1.125	0.52
3/4	FC-752-12FO	FF-751	1 1/16-12 UNF	4.81	3.72	1.65	1.500	1.32
3/4	FC-752-12FP	FF-751	3/4-14 NPSF	4.81	3.72	1.65	1.500	1.34

Standard Port Configurations: **FP** - Female Pipe Thread **FO** - Female Straight Thread

* This dimension represents the portion of the nipple that is exposed when the nipple and coupler are connected.



FEM Series couplings meet or exceed ISO 16028 design and performance requirements. The flush valves eliminate spillage and air inclusion when connecting and disconnecting. Coupler and nipple bodies have a modular design with increased flexibility for end port options. FEC nipples provide a connect-under-pressure option for trapped residual pressure.

Features

- Flush, non-spill valving
- Global interchangeability with other ISO 16028 compliant couplings
- Hardened nipple bodies
- Sleeve-Lok design standard
- Connect-under-pressure FEC nipple option
- Protective zinc nickel plating

Applications include:

- Skid loader attachments
- Hydraulic tools

Materials of Construction

Body: Steel

Finish: 1/4", 5/8", 1" - Zinc with Clear Trivalent Chromate
3/8", 1/2", 3/4" - Zinc Nickel

Valve: Flush face valving

Seal: Polyurethane and Nitrile

Performance

FEM Series (1/4", 3/8" & 1/2")
Test Fluid: Oil - 150 SUS

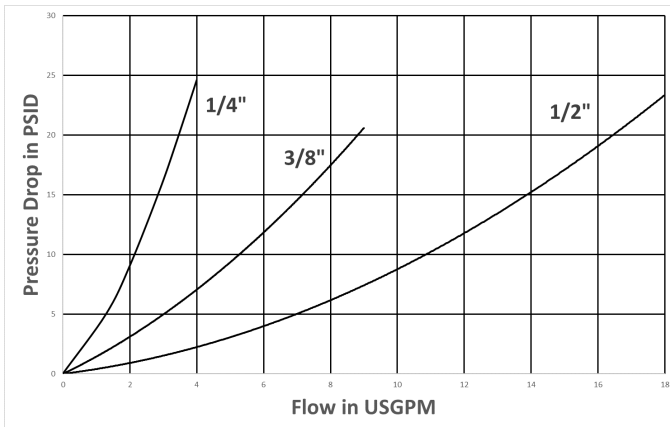

FEM Series (5/8", 3/4" & 1")
Test Fluid: Oil - 150 SUS

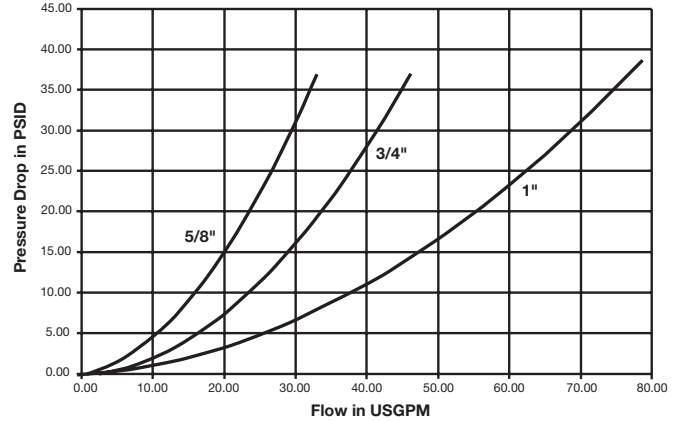

FEM Series Specifications

Body Size	Rated Pressure (psi)	Rated Flow (gpm)	Temperature Range	Spillage (ml) max. per disconnect	Air Inclusion (ml) max. per connect	Body Material	Sleeve Type	Seal Material
1/4	4568	3	-40° to +250°F	.015	.020	Steel	Push to Connect	Polyurethane and Nitrile
3/8	5000	6		.015	.020			
1/2	5000	12		.020	.070			
5/8	3625	20		.030	.070			
3/4	5000	26		.150	.100			
1	2900	50		.200	.150			





FEM Series Couplers

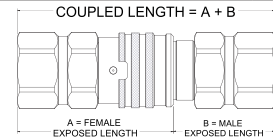
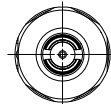
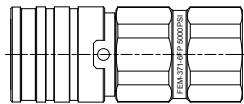

Body Size	Coupler Part Number	Port End	Length	Coupled Length (when connected to corresponding nipple)	Largest Diameter	Wrench Flats	Weight (lbs.)
1/4	FEM-251-4FP	1/4-18 NPTF	1.96	3.98	1.16	27mm	0.52
1/4	FEM-251-6FO	9/16-18 UNF	2.08	4.06	1.16	27mm	0.51
3/8	FEM-371-6FP	3/8-18 NPTF	3.06	5.02	1.26	30 mm	0.77
3/8	FEM-371-8FO	3/4-16 UNF	3.06	5.02	1.26	30 mm	0.74
3/8	FEM-371-8FB	G1/2 BSPP	3.17	5.23	1.31	30 mm	0.75
1/2	FEM-501-8FP	1/2-14 NPTF	3.26	5.74	1.59	36 mm	1.22
1/2	FEM-501-8FO	3/4-16 UNF	3.26	5.74	1.59	36 mm	1.22
1/2	FEM-501-8FB	G1/2 BSPP	3.07	5.35	1.59	36 mm	1.14
1/2	FEM-501-10FO	7/8-14 UNF	3.08	5.38	1.59	36 mm	1.12
1/2	FEM-501-12FO	1 1/16-12 UNF	3.26	5.74	1.59	36 mm	1.11
1/2	FEM-501-12FB	G3/4 BSPP	3.25	5.71	1.59	36 mm	1.14
5/8	FEM-621-12FO	1 1/16-12 UNF	3.70	5.64	1.69	40 mm	1.34
3/4	FEM-751-12FP	3/4-14 NPTF	3.88	6.17	1.97	46 mm	2.04
3/4	FEM-751-12FO	1 1/16-12 UNF	4.04	6.48	1.97	46 mm	2.10
1	FEM-1001-16FP	1-11 1/2-NPTF	4.21	6.79	2.36	55 mm	3.08
1	FEM-1001-16FO	1 5/16-12 UNF	4.21	6.79	2.36	55 mm	3.03

FEM Series Couplers - 90 Degree

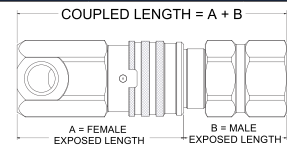
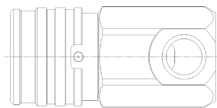

Body Size	Coupler Part Number	Port End	Length	Coupled Length (when connected to corresponding nipple)	Largest Diameter	Wrench Flats	Weight (lbs.)
1/2	FEM-501-C6FP	3/8-18 NPTF	3.26	5.74	1.59	32 mm	1.187
1/2	FEM-501-C8FO	3/4-16 ORB	3.25	5.71	1.59	36 mm	1.187

FEM Series Couplers - Bulkhead

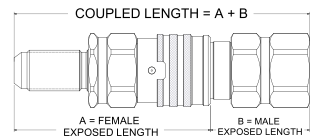
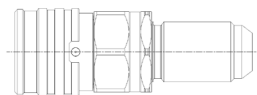

Body Size	Coupler Part Number	Port End	Length	Coupled Length (when connected to corresponding nipple)	Largest Diameter	Wrench Flats	Weight (lbs.)
1/2	FEM-501-10BMF	7/8-14 UNF	4.02	6.32	1.54	32 mm	1.07
1/2	FEM-501-10BMS	1-14 UNS	4.02	6.32	1.59	36 mm	1.16

Code	Description	Part Number Example
suffix -E5	Ethylene Propylene seal material (EPR)	FEM-501-8FP-E5
suffix -E4	Fluorocarbon seal material	FEM-501-8FP-E4

Contact QCD for availability and additional options.

To select proper seal materials, see Fluid Compatibility Chart or contact QCD.





FEM Series Nipples

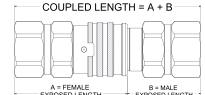
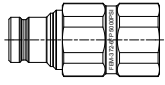

Body Size	Nipple Part Number	Port End	Length	Coupled Length (when connected to corresponding coupler)	Largest Diameter	Wrench Flats	Weight (lbs.)
1/4	FEM-252-4FP	1/4-18 NPTF	1.71	3.98	0.96	22 mm	0.20
1/4	FEM-252-6FO	9/16-18 UNF	1.95	4.06	0.96	22 mm	0.19
3/8	FEM-372-6FP	3/8-18 NPTF	2.59	5.02	1.26	30 mm	0.48
3/8	FEM-372-8FO	3/4-16 UNF	2.59	5.02	1.26	30 mm	0.45
3/8	FEM-372-8FB	G1/2 BSPP	2.69	5.22	1.26	30 mm	0.47
1/2	FEM-502-8FP	1/2-14 NPTF	3.13	5.74	1.57	36 mm	0.84
1/2	FEM-502-8FO	3/4-16 UNF	3.13	5.74	1.57	36 mm	0.85
1/2	FEM-502-8FB	G1/2 BSPP	2.95	5.35	1.57	36 mm	0.77
1/2	FEM-502-10FO	7/8-14 UNF	2.95	5.38	1.57	36 mm	0.75
1/2	FEM-502-12FO	1 1/16-12 UN	3.13	5.74	1.57	36 mm	0.74
1/2	FEM-502-12FB	G3/4 BSPP	3.13	5.71	1.57	36 mm	0.76
5/8	FEM-622-12FO	1 1/16-12 UN	3.09	5.64	1.57	36 mm	0.72
3/4	FEM-752-12FP	3/4-14 NPTF	3.17	6.17	1.97	46 mm	1.35
3/4	FEM-752-12FO	1-1/16 12 UN	3.33	6.48	1.97	46 mm	1.42
1	FEM-1002-16FP	1-11 1/2 NPTF	3.85	6.79	2.36	55 mm	1.94
1	FEM-1002-16FO	1-5/16 12 UN	3.85	6.79	2.36	55 mm	1.90

FEM Series Nipples - 90 Degree

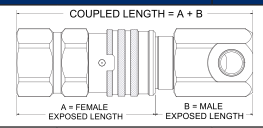
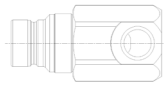

Body Size	Coupler Part Number	Port End	Length	Coupled Length (when connected to corresponding nipple)	Largest Diameter	Wrench Flats	Weight (lbs.)
1/2	FEM-502-C6FP	3/8-18 NPTF	3.13	5.74	1.57	36 mm	.82
1/2	FEM-502-C8FO	3/4-16 ORB	3.13	5.71	1.57	36 mm	.82

FEM Series Nipples - Bulkhead

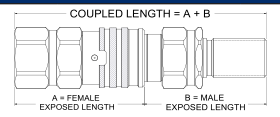

Body Size	Nipple Part Number	Port End	Length	Coupled Length (when connected to corresponding nipple)	Largest Diameter	Wrench Flats	Weight (lbs.)
1/2	FEM-502-10BMF	7/8-14 UNF	3.85	7.24	1.38	31.75 mm	.84
1/2	FEM-502-10BMS	1-14 UNS	3.85	7.24	1.38	31.75 mm	.84

Dust Caps - FEM Series



Body Size	Nipple Dust Cap	Coupler Dust Cap	Material	Body Size	Nipple Dust Cap	Coupler Dust Cap	Material
1/4	CFE-252-PN	PFE-251-PN	PVC	5/8	CFE-622-PN	PFE-621-PN	PVC
3/8	CFE-372-PN	PFE-371-PN	PVC	3/4	CFE-752-PN	PFE-751-PN	PVC
1/2	CFE-502-PN	PFE-501-PN	PVC	1	CFE-1002-PN	PFE-1001-PN	PVC

Standard Port Configurations: FP - Female Pipe Thread FO - Female Straight Thread BMF - Bulkhead Flare BMS - Bulkhead Face Seal
 FB - Female British Standard Parallel Pipe Other Fitting Port Configurations available upon request.

* This dimension represents the portion of the nipple that is exposed when the nipple and coupler are connected.



Applications

Parker FEC Series nipple provide connect-under-pressure capability with up to 3000 PSI of trapped pressure in the nipple and are ideal for applications where residual pressure makes reconnect difficult. Utilized primarily in the construction equipment market, FEC Series products are commonly found on hydraulic attachments used in skid steer applications. The FEC Series mates with the FEM Series interface ISO 16028 couplers.

Features:

- Connect-Under-Pressure nipple
- Hardened locking surface
- Steel construction, Chromium-6 Free plating for corrosion resistance
- Anti blowout bonded nipple seal
- Flush face valving

Connect Under Pressure Operation

FEC Series products operate slightly different from traditional non-spill couplings. With no pressure in the coupler and up to 3000 PSI of trapped pressure in the nipple, begin to couple the mating halves. Delay momentarily during connection to allow trapped pressure to equalize with the mating half before completing the connection.

Performance

FEC Series (1/2", 5/8", 3/4")
Test Fluid: Oil - 200 SUS

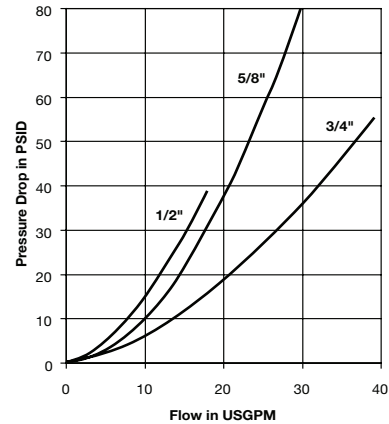

FEC Series Specifications					
Body Size	Rate Pressure (psi)	Rated Connect-Under-Pressure Capability	Rated Flow (gpm)	Spillage (ml) max. per disconnect	Air Inclusion (ml) max. per connect
1/2	3625	3000	12	.020	.070
5/8	3625	1700	20	.003	.070
3/4	5000	1500	26	.150	.100

FEC Series Connect Under Pressure Nipples

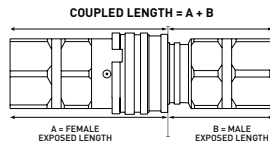

Body Size	Part Number	Mating Half	Port End	Length	Coupled Length (when connected to corresponding nipple)	Largest Diameter	Wrench Flats
1/2	FEC-502-8FP	FEM-501	1/2-14 NPTF	3.50	5.82	1.22	1.125
1/2	FEC-502-10FO	FEM-501	7/8-14 UNF	3.50	5.82	1.22	1.125
1/2	FEC-502-12FO	FEM-501	1 1/16-12 UNF	3.79	6.36	1.65	1.500
5/8	FEC-622-12FO	FEM-621	1 1/16-12 UN	3.39	5.94	1.65	1.500
3/4	FEC-752-12FO	FEM-751	1 1/16-12 UN	4.56	7.72	1.96	1.81

Standard Port Configurations: **FP** - Female Pipe Thread **FO** - Female Straight Thread

* This dimension represents the portion of the nipple that is exposed when the nipple and coupler are connected.



FS Series dry disconnect couplings are ideal for closed system transfer and dispensing of chemicals and other fluids. The flush valves eliminate spillage and air inclusion when connecting and disconnecting to result in minimal environmental contamination.

Features:

- Flush, non-spill valves enable ease of cleaning
- 316 stainless steel material for chemical compatibility
- Push to connect operation
- Fluorocarbon standard seal material with options available

Applications include:

- Chemical dispensing systems
- Chemical processing
- Food processing
- Corrosive media transfer

Materials of Construction

- Machined Parts:** Stainless Steel, AISI type 316
Springs: Stainless Steel, AISI type 316.
Locking Balls: 1/4" - 302 SS;
 3/8" - 1" - Tungsten Carbide
Backup Washers: PTFE
Elastomer Seals: Fluorocarbon is standard.
 Wide range is available.

Specifications					
Body Size	Rated Pressure (psi)	Rated Flow (gpm)	Spillage (ml) max. per disconnect	Air Inclusion (ml) max. per connect	CV
1/4	2000	3	.015	.010	0.90
3/8	2000	6	.015	.020	1.80
1/2	2000	12	.020	.070	3.00
3/4	2000	28	.150	.100	7.00
1	2000	50	.250	.182	10.1

Temperature Range (continuous)		
Part No. Seal Suffix	Seal Compound	Temp° F Rating
None*	Fluorocarbon	-15 to 400
E5	Ethylene Propylene (EPR)	-65 to 300
E1	Nitrile	-40 to 250
E35	Perfluoroelastomer (Contact Factory)	-20 to 600

*Fluorocarbon is standard seal.

Performance Flow Data

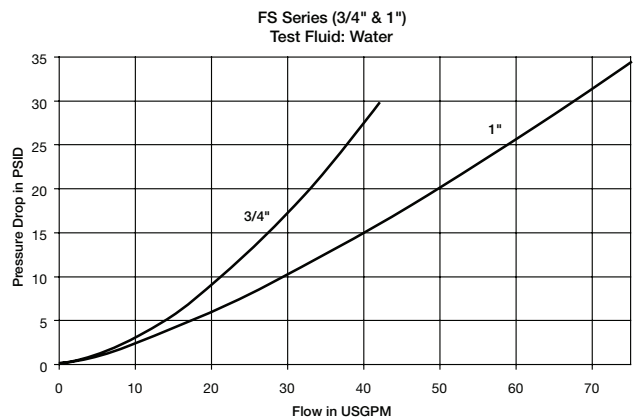
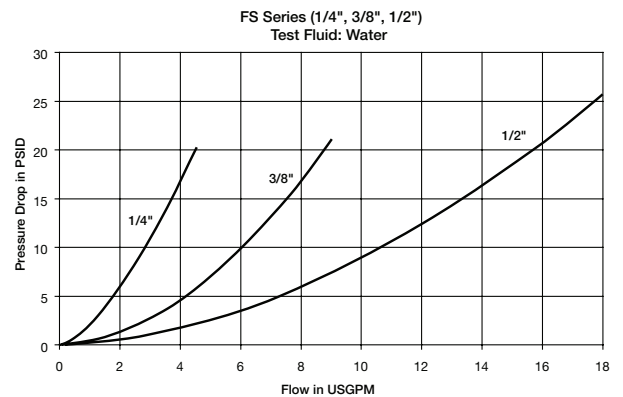



FS Series Couplers - Female Pipe Thread



Body Size	Coupler Part Number	Port End	Length	Largest Diameter	Wrench Flats	Weight (lbs.)
1/4	FS-251-4FP	1/4-18 NPT	1.79	1.06	1.00	0.25
1/4	FS-251-4MP	1/4-18 NPTF	2.00	1.06	1.00	0.25
1/4	FS-251-6FO	9/16-18UNF	1.92	1.06	1.00	0.24
3/8	FS-371-6FP	3/8-18 NPT	2.52	1.30	1.06	0.58
3/8	FS-371-8FO	3/4-16 UNF	2.83	1.30	1.06	0.63
1/2	FS-501-8FP	1/2-14 NPT	2.74	1.58	1.38	0.92
1/2	FS-501-10FO	7/8-14 UNF	2.86	1.58	1.38	0.96
3/4	FS-751-12FP	3/4-14 NPT	3.63	1.99	1.75	2.00
3/4	FS-751-12FO	1-1/16-12 UNF	3.73	1.99	1.75	2.04
1	FS-1001-16FP	1-11 1/2 NPT	4.14	2.25	1.87	2.76
1	FS-1001-16FO	1-15/16-12 UNF	4.24	2.25	1.87	2.80

FS Series Nipples - Female Pipe Thread



Body Size	Coupler Part Number	Port End	Length	Largest Diameter	Wrench Flats	Weight (lbs.)
1/4	FS-252-4FP	1/4-18 NPT	1.66	1.06	1.00	0.18
1/4	FS-252-4MP	1/4-18 NPT	1.87	1.06	1.00	0.18
1/4	FS-252-6FO	9/16-18 UNF	1.78	1.06	1.00	0.17
3/8	FS-372-6FP	3/8-18 NPT	2.31	1.08	0.94	0.26
3/8	FS-372-8FO	3/4-16 UNF	2.45	1.30	1.06	0.30
1/2	FS-502-8FP	1/2-14 NPT	2.75	1.58	1.12	0.44
1/2	FS-502-10FO	7/8-14 UNF	2.85	1.58	1.12	0.48
3/4	FS-752-12FP	3/4-14 NPT	3.38	1.99	1.50	1.02
3/4	FS-752-12FO	1-1/16-12 UNF	3.38	1.65	1.50	1.14
1	FS-1002-16FP	1-11 1/2 NPT	3.89	2.17	1.87	1.60
1	FS-1002-16FO	1-5/16 12 UNF	3.89	2.17	1.87	1.64

Standard Port Configurations: FP - Female Pipe Thread MP - Male Pipe Thread FO - Female Straight Thread

Dust Caps - FS Series



Body Size	Coupler Dust Cap-Rubber	Nipple Dust Cap-Rubber
1/4	FR-25	FR-25
3/8	NR-50	NR-37
1/2	FR-501	FR-502
3/4	FR-751	FR-752
1	FR-1001	FR-1002



FS Series Repair Kits

Repair kits are available for both coupler and nipple half of FS coupling. Kits include replacement elastomer seals, valve assembly and instructions to perform rebuild. Spline tool must be ordered separately to accomplish coupler half repair. Other tools required: Vise, Allen Wrench and Open End Wrench.

FS Repair Kits		
TOOL Spline tool for Coupler Repair	Replacement Seals	
	No Suffix	Fluorocarbon Seals
	E5	Ethylene Propylene (EPR)
	E35	Perfluoroelastomer (Contact Factory for Seal Options).

Nipple Repair Kits			
1/4	FS-252-KIT	FS-252-KIT-E5	-
3/8	FS-372-KIT	FS-372-KIT-E5	-
1/2	FS-502-KIT	FS-502-KIT-E5	-
3/4	FS-752-KIT	FS-752-KIT-E5	-
1	FS-1002-KIT	FS-1002-KIT-E5	-

Coupler Repair Kits			
1/4	N/A	N/A	N/A
3/8	FS 371-KIT	FS 371-ES	FF/FS 371-TOOL
1/2	FS-501-KIT	FS-501-KIT-E5	FS-501-TOOL
3/4	FS-751-KIT	FS-751-KIT-E5	FF/FS-751-TOOL
1	FS-1001-KIT	FS-1001-KIT-E5	FF/FS-751-TOOL



Quick Couplings



ST Series non-valved couplings provide maximum flow and low pressure drop. The smooth, open bore allows easy cleaning in applications where the same lines are used for more than one media.

Features

- Steel nipples are case hardened for resistance to Brinelling
- Functionally interchanges with similar straight-through design couplings
- Standard Nitrile seals
- Material options available

Applications:

- High pressure water
- Steam washers
- Carpet cleaners



Specifications

Body Size	Rated Pressure (psi) Brass Coupler/Nipple	Rated Pressure (psi) Brass Coupler/Steel Nipple	Rated Pressure (psi) SS Coupler/Nipple	Temperature Range (standard seals)	Rated Flow
1/8	2500	2600	4200	-40° to +250° F	3
1/4	5200	5500	6700		6
3/8	2700	3500	5500		12
1/2	2200	2700	3000		12
3/4	1700	2700	3000		28
1	1200	2000	1700		50
1-1/4	1700	-	-		76
1-1/2	1400	-	-		100

Performance

ST Series (1/8", 1/4", 3/8", 1/2")
Test Fluid: Oil - 150 SUS

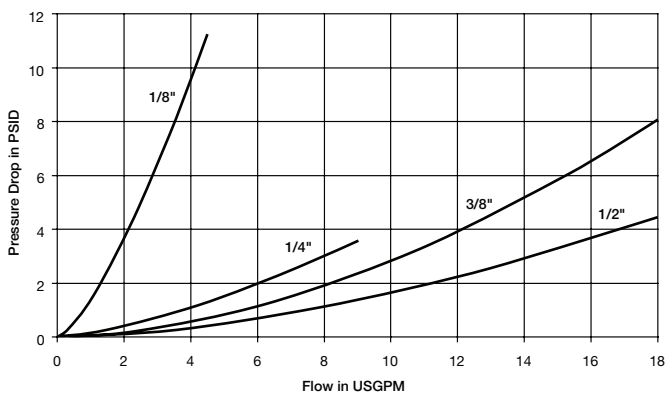

ST Series (3/4", 1", 1-1/4")
Test Fluid: Oil - 150 SUS

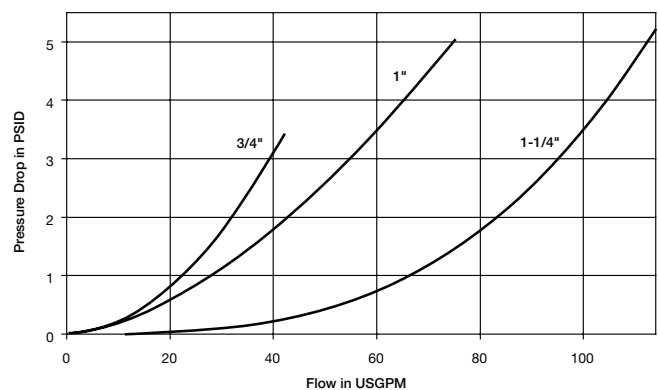



ST Series Couplers - Female Pipe Thread



Body Size	Brass Part Number	303 Stainless Part Number	Port End	Length	Largest Diameter	Wrench Flats	Brass Weight (lbs.)	Stainless Weight (lbs.)
1/8	BST-1	SST-1	1/8-27 NPTF	1.06	0.69	0.56	0.06	0.05
1/4	BST-2	SST-2	1/4-18 NPTF	1.54	0.94	0.81	0.17	0.15
3/8	BST-3	SST-3	3/8-18 NPTF	1.64	1.16	1.00	0.26	0.24
1/2	BST-4	SST-4	1/2-14 NPTF	1.98	1.30	1.13	0.59	0.37
3/4	BST-6	SST-6	3/4-14 NPTF	2.15	1.66	1.44	0.62	0.57
1	BST-8	SST-8	1-11 1/2 NPTF	2.43	2.02	1.75	0.99	0.93
1-1/4	BST-10	-	1 1/4-11 1/2 NPTF	2.44	2.51	2.00	1.38	-
1-1/2	BST-12	-	1 1/2-11 1/2 NPTF	2.88	3.00	2.50	2.43	-

ST Series Couplers - Male Pipe Thread



Body Size	Brass Part Number	303 Stainless Part Number	Port End	Length	Largest Diameter	Wrench Flats	Brass Weight (lbs.)	Stainless Weight (lbs.)
1/8	BST-1M	SST-1M	1/8-27 NPTF	1.06	0.69	0.56	0.05	0.05
1/4	BST-2M	SST-2M	1/4-18 NPTF	1.69	0.94	0.81	0.13	0.16
3/8	BST-3M	SST-3M	3/8-18 NPTF	1.75	1.16	1.00	0.25	1.16
1/2	BST-4M	SST-4M	1/2-14 NPTF	1.94	1.30	1.13	0.34	1.30
3/4	BST-6M	SST-6M	3/4-14 NPTF	2.17	1.66	1.44	-	1.66
1	BST-8M	SST-8M	1-11 1/2 NPTF	2.53	2.02	1.75	0.85	2.02





ST Series Nipples- Female Pipe Thread



Body Size	Brass Part Number	Weight. (lbs.)	Steel Part Number	Weight. (lbs.)	303 Stainless Part Number	Weight. (lbs.)	Length	Largest Diameter	Wrench Flats
1/8	BST-N1	0.03	ST-N1	0.03	SST-N1	0.02	0.98	0.65	0.56
1/4	BST-N2	0.07	ST-N2	0.07	SST-N2	0.07	1.46	0.87	0.75
3/8	BST-N3	0.12	ST-N3	0.11	SST-N3	0.11	1.62	1.59	0.08
1/2	BST-N4	0.23	ST-N4	0.21	SST-N4	0.21	1.85	1.30	1.13
3/4	BST-N6	0.33	ST-N6	0.32	SST-N6	0.32	2.15	1.59	1.38
1	BST-N8	0.52	ST-N8	0.49	SST-N8	0.48	2.35	1.88	1.63
1-1/4	BST-N10	0.85	-	-	-	-	2.38	2.31	2.00
1-1/2	BST-N12	1.45	-	-	-	-	2.81	2.74	2.38

ST Series Nipples- Male Pipe Thread



Body Size	Brass Part Number	Weight. (lbs.)	Steel Part Number	Weight. (lbs.)	303 Stainless Part Number	Weight. (lbs.)	Length	Largest Diameter	Wrench Flats
1/8	BST-N1M	0.02	ST-N1	0.02	SST-N1	0.02	1.04	0.51	0.44
1/4	BST-N2M	0.06	ST-N2	0.05	SST-N2	0.05	1.53	0.65	0.56
3/8	BST-N3M	0.08	ST-N3	0.07	SST-N3	0.08	1.69	0.79	0.69
1/2	BST-N4M	0.15	ST-N4	0.13	SST-N4	0.13	1.94	1.01	0.88
3/4	BST-N6M	0.23	ST-N6	0.21	SST-N6	0.22	2.19	1.23	1.06
1	BST-N8M	0.46	ST-N8	0.43	SST-N8	0.43	2.51	1.59	1.38
1-1/4	BST-N10M	0.96	-	-	-	-	2.85	2.17	1.88
1-1/2	BST-N12M	1.46	-	-	-	-	3.25	2.45	2.13





Pioneer Water Service Quick Couplings add convenience and efficiency wherever water hoses are frequently connected and disconnected. The durable 4-ball locking mechanism provides a secure connection.

Features:

- Brass and stainless steel construction
- Nitrile seals

Applications include:

- Garden hoses
- Wash down systems
- Mobile water tank lines

Specifications			
Body Size	Rated Pressure (psi)	Rated Flow (gpm)	Temperature Range (std seals)
3/4	200	28	-40° to +250° F

Coupler					
Body Size	Coupler Part Number	Port End	Length	Largest Diameter	Weight (lbs.)
3/4	1163-60	3/4-11 1/2 NH	1.16	1.21	0.12

Nipple					
Body Size	Coupler Part Number	Port End	Overall Length	Exposed Length	Weight (lbs.)
3/4	1163-61	3/4-11 1/2 NH	1.25	0.50	0.08





Pioneer Industrial Interchange Nipples are compatible for use with 20 Series, HF Series, Universal or E-z-mate couplers. The standard male tip of the pneumatic industry, these nipples are interchangeable with similar nipples manufactured to the same requirements.

Features:

- Conforms to A-A-59439 (MIL-C-4109F, ISO 6150-B) requirements for global interchangeability
- Hardened wear points and load-bearing areas
- Unvalved style nipple mates with valved couplers

Applications include:

- Air compressors
- Pneumatic tools
- Drop-down air lines

Nipples- Female Pipe Thread



Body Size	Part Number Brass	Part Number Steel	Port End	Length	Largest Diameter	Wrench Flats	Weight (lbs.)
1/4	-	H1C	1/8-27 NPTF	1.48	0.58	0.50	0.03
1/4	BH3C	H3C	1/4-18 NPTF	1.56	0.72	0.62	0.05
1/4	-	H3C-E	3/8-18 NPTF	1.60	0.94	0.81	0.08
3/8	-	H1E	1/4-18 NPTF	1.60	0.72	0.62	0.06
3/8	BH3E	H3E	3/8-18 NPTF	1.69	0.94	0.81	0.10
3/8	-	H3E-F	1/2-14 NPTF	1.84	1.16	1.00	0.13
1/2	-	H1F	3/8-18 NPTF	2.03	0.94	0.81	0.12
1/2	BH3F	H3F	1/2-14 NPTF	2.20	1.16	1.00	0.19
1/2	-	H3F-G	3/4-14 NPTF	2.30	1.44	1.25	0.26
3/4	-	H3G-F	1/2-14 NPTF	2.22	1.16	1.00	0.23
3/4	-	H3G	3/4-14 NPTF	2.18	1.44	1.25	0.34
3/4	-	H3G-J	1-11 1/2 NPTF	2.41	1.80	1.63	0.47





Nipples- Male Pipe Thread



Body Size	Part Number Brass	Part Number Steel	Port End	Length	Largest Diameter	Wrench Flats	Weight (lbs.)
1/4	-	H0C	1/8-27 NPTF	1.68	0.58	0.50	0.05
1/4	BH2C	H2C	1/4-18 NPTF	1.66	0.65	0.56	0.06
1/4	-	H2C-E	3/8-18 NPTF	1.90	0.80	0.69	0.07
3/8	-	H00E	1/8-27 NPTF	1.68	0.72	0.62	0.08
3/8	-	H0E	1/4-18 NPTF	1.90	0.72	0.62	0.08
3/8	BH2E	H2E	3/8-18 NPTF	1.90	0.80	0.69	0.09
3/8	-	H2E-F	1/2-14 NPTF	2.03	1.02	0.88	0.15
1/2	-	H0F	3/8-18 NPTF	2.20	0.79	0.69	0.16
1/2	BH2F	H2F	1/2-14 NPTF	2.35	1.01	0.88	0.18
1/2	-	H2F-G	3/4-14 NPTF	2.40	1.22	1.06	0.24
3/4	-	H2G-F	1/2-14 NPTF	2.32	1.16	1.00	0.22
3/4	BH2G	H2G	3/4-14 NPTF	2.28	1.22	1.06	0.28
3/4	-	H2G-J	1-11 1/2 NPTF	2.56	1.52	1.31	0.36

Nipples- Standard Hose Barb



Body Size	Part Number Steel	Hose I.D.	Length	Largest Diameter	Weight (lbs.)
1/4	H8C	1/4	1.72	0.46	0.04
1/4	H8C-D	5/16	1.96	0.50	0.04
1/4	H9C	3/8	1.96	0.50	0.05
3/8	H5E	3/8	1.85	0.59	0.07
3/8	H6E	1/2	2.09	0.68	0.08
1/2	H4F	3/8	2.36	0.66	0.10
1/2	H5F	1/2	2.36	0.66	0.11
1/2	H5F-G	3/4	2.95	0.87	0.18
3/4	H5G-F	1/2	2.47	0.93	0.19
3/4	H5G	3/4	3.00	0.93	0.25
3/4	H5G-J	1	3.24	1.24	0.36





Nipples- Push-Lok Hose Barb*



Body Size	Part Number Steel	Hose I.D.	Length	Largest Diameter	Weight (lbs.)
1/4	H8CP	1/4	1.74	0.69	0.04
1/4	H9CP	3/8	1.96	0.86	0.05
3/8	H4EP	1/4	1.87	0.69	0.06
3/8	H5EP	3/8	2.02	0.86	0.07
3/8	H6EP	1/2	2.21	0.97	0.09
1/2	H4FP	3/8	2.36	0.86	0.11
1/2	H5FP	1/2	2.48	0.97	0.11
1/2	H6FP	5/8	2.95	1.14	0.14

* Push-Lok hose barbs are designed for use with Parker Push-Lok hose and do not require clamps.





20 Series Pneumatic Couplers mate with Industrial Interchange nipples, the standard male tip of the pneumatic industry. Available options include Sleeve-Lok, stainless steel locking balls and springs, and grip-ring sleeve.

Features:

- Mates with Industrial Interchange nipples manufactured to A-A-59439 (MIL-C-4109F, ISO 6150-B) global standards
- 1/4" body size has a brass body and steel valve, 3/8" body size has all steel construction
- Standard seal is Nitrile

Applications:

- Air compressors
- Pneumatic tools
- Water
- Grease
- Paint

Performance 20 Series (1/4", 3/8", 1/2" sizes)

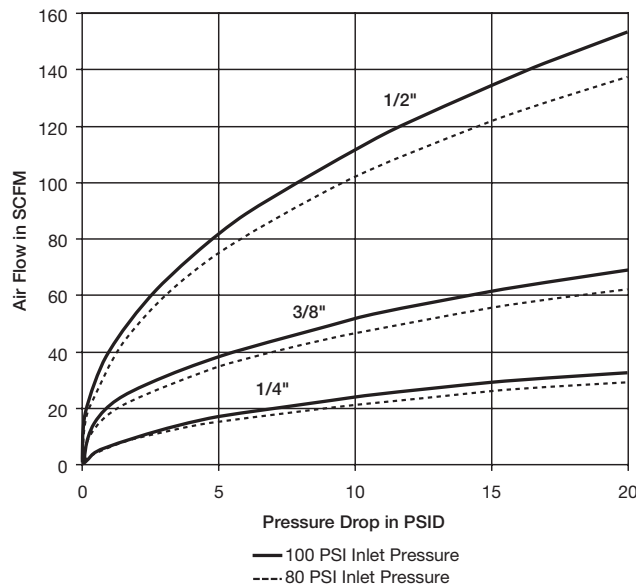

20 Series Specifications

Body Size	Rate Pressure (psi)	Temperature Range (standard seals)	Locking Device	Vacuum Data (in. hg)	Disconnected (coupler only)	Connected
1/4	300	-40° to +250° F	4 balls	-	Not Recommended	27.4
3/8	300		8 balls	-		27.4
1-2	300		8 balls	-		27.4





Couplers- Female Pipe Thread



Body Size	Part Number Brass	Part Number Steel	Port End	Length	Largest Diameter	Wrench Flats	Weight (lbs.)
1/4	B23A	-	1/8-27 NPTF	1.83	0.90	0.75	0.20
1/4	B23	-	1/4-18 NPTF	1.83	0.90	0.75	0.19
1/4	B23E	-	3/8-18 NPTF	1.95	0.94	0.81	0.20
3/8	-	25C	1/4-18 NPTF	2.22	1.06	0.88	0.30
3/8	B25	25	3/8-18 NPTF	2.28	1.06	0.88	0.32
3/8	-	25F	1/2-14 NPTF	2.55	1.16	1.00	0.34
1/2	-	17E	3/8-18 NPTF	2.74	1.19	1.00	0.46
1/2	B17	17	1/2-14 NPTF	2.96	1.19	1.00	0.50
1/2	-	17G	3/4-14 NPTF	3.19	1.44	1.25	0.56

Couplers- Male Pipe Thread



Body Size	Part Number Brass	Part Number Steel	Port End	Length	Largest Diameter	Wrench Flats	Weight (lbs.)
1/4	B22A	-	1/8-27 NPTF	1.89	0.90	0.75	0.20
1/4	B22	-	1/4-18 NPTF	2.05	0.90	0.75	0.19
1/4	B22E	-	3/8-18 NPTF	2.08	0.94	0.75	0.20
3/8	-	24C	1/4-18 NPTF	2.36	1.06	0.88	0.30
3/8	B24	24	3/8-18 NPTF	2.39	1.06	0.88	0.32
3/8	-	24F	1/2-14 NPTF	2.55	1.16	0.88	0.34
1/2	-	16E	3/8-18 NPTF	2.93	1.19	1.00	0.46
1/2	B16 *	16	1/2-14 NPTF	3.08	1.19	1.00	0.50
1/2	-	16G	3/4-14 NPTF	3.21	1.30	1.13	0.56

* Coupler has brass body and steel sleeve.





Couplers- Standard Hose Barb



Body Size	Part No. Brass	Part No. Steel	Hose I.D.	Length	Largest Diameter	Wrench Flats	Weight (lbs.)
1/4	B20-3B	-	1/4	2.49	0.90	0.75	0.18
1/4	B20-4B	-	5/16	2.49	0.90	0.75	0.18
1/4	B20-5B	-	3/8	2.49	0.90	0.75	0.18
3/8	-	24-5B	3/8	2.86	1.06	0.88	0.27
3/8	-	24-6B	1/2	3.08	1.06	0.88	0.28
1/2	-	16-5B	3/8	3.37	1.19	1.00	0.41
1/2	-	16-6B	1/2	3.62	1.19	1.00	0.43
1/2	-	16-7B	3/4	3.96	1.19	1.00	0.48

Couplers- Push-Lok Hose Barb



Body Size	Part No. Brass	Part No. Steel	Hose I.D.	Length	Largest Diameter	Wrench Flats	Weight (lbs.)
1/4	B20-3BP	-	1/4	2.32	0.90	0.75	0.18
1/4	B20-4BP	-	3/8	2.47	0.90	0.75	0.19
3/8	-	24-5BP	3/8	2.86	1.06	0.88	0.27
1/2	-	16-5BP	3/8	3.37	1.19	1.00	0.41
1/2	-	16-6BP	1/2	3.62	1.19	1.00	0.43

* Push-Lok hose barbs are designed for use with Parker Push-Lok hose and do not require clamps.

NOTE: See Table of Contents for pneumatic Industrial Interchange nipples used with 20 Series couplers.





Rectus 25 Series Pneumatic Couplers are designed to increase flow and reduce pressure drop through the coupling. Rectus 25 nipples have up to 2-1/2 times larger flow area than standard industrial interchange nipples. The increased flow results in greater tool efficiency and decreased air costs. Couplers are nickel plated brass and nipples are steel.

Features:

- Aerodynamic valve design
- Flow rates on 1/4" is greater than many 3/8" body size couplers
- Integral sleeve guard protects against accidental disconnection
- Functionally interchanges with a common high-flow European design. 1/4 Rectus 25 interchanges with CEJN 320.
- Standard seal is Nitrile

Applications include:

- Air compressors
- Pneumatic tools
- Drop-down air lines

Performance Rectus 25 Series (1/4" body size)
with 1/4" Female NPSF

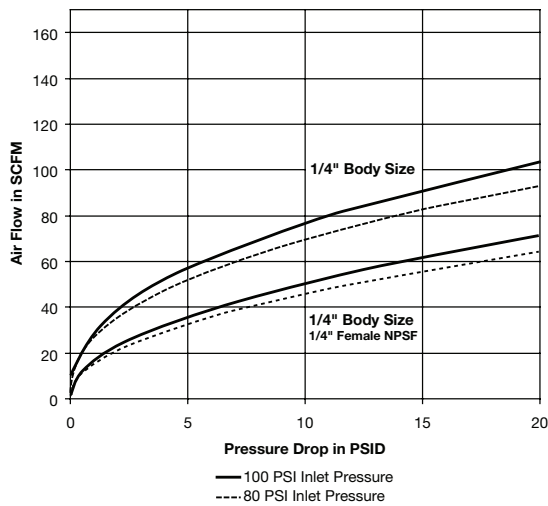

RF Series Specifications

Body Size	Rated Pressure (psi)	Temperature Range (standard seals)	Locking Device	Vacuum Data (in. HG)	Disconnected (coupler only)	Connected
1/4	300	-4° to +212° F	4 balls	-	Not Recommended	Not Recommended



Couplers- Female Pipe Thread



Body Size	New Part No. Nickel Plated Brass	Old Part No.	Port End	Length	Largest Diameter	Wrench Flats	Weight (lbs.)
1/4	25KAIN13MPN	RF-251-4FP	1/4-18 NPSF	2.19	0.99	0.81	0.26
1/4	25KAIN17MPN	RF-251-6FP	3/8-18 NPSF	2.34	0.99	0.81	0.27

Couplers- Male Pipe Thread



Body Size	New Part No. Nickel Plated Brass	Old Part No.	Port End	Length	Largest Diameter	Wrench Flats	Weight (lbs.)
1/4	25KAAN13MPN	RF-251-4MP	1/4-18 NPTF	2.34	0.99	0.81	0.24
1/4	25KAAN17MPN	RF-251-6MP	3/8-18 NPTF	2.37	0.99	0.81	0.25

Couplers- Standard Hose Barb



Body Size	New Part No. Nickel Plated Brass	Old Part No.	Hose I.D.	Length	Largest Diameter	Wrench Flats	Weight (lbs.)
1/4	25KATF06MPN	RF-251-4HB	1/4	2.81	0.99	0.81	0.26
1/4	25KATF10MPN	RF-251-6HB	3/8	2.81	0.99	0.81	0.27

Couplers- Push-Lok Hose Barb



Body Size	New Part No. Nickel Plated Brass	Old Part No.	Hose I.D.	Length	Largest Diameter	Wrench Flats	Weight (lbs.)
1/4	25KATP06MPN	RF-251-4PL	1/4	2.64	0.99	0.81	0.26
1/4	25KATP10MPN	RF-251-6PL	3/8	2.78	0.99	0.81	0.27





Nipples- Female Pipe Thread



Body Size	New Part No. Steel	Old Part No.	Port End	Length	Largest Diameter	Wrench Flats	Weight (lbs.)
1/4	25SFIN13SXZ	RF-254-4FP	1/4-18 NPTF	1.45	0.72	0.62	0.06
1/4	25SFIN17SXZ	RF-254-6FP	3/8-18 NPTF	1.50	0.94	0.81	0.09

Nipples- Male Pipe Thread



Body Size	New Part No. Steel	Old Part No.	Port End	Length	Largest Diameter	Wrench Flats	Weight (lbs.)
1/4	25SFAN13SXZ	RF-254-4MP	1/4-18 NPTF	1.60	0.65	0.56	0.05
1/4	25SFAN17SXZ	RF-254-6MP	3/8-18 NPTF	1.67	0.75	0.69	0.08

Nipples- Standard Hose Barb



Body Size	New Part No. Steel	Old Part No.	Hose I.D.	Length	Largest Diameter	Weight (lbs.)
1/4	25SFTF06SXZ	RF-254-4HB	1/4	1.66	0.50	0.04
1/4	25SFTF10SXZ	RF-254-6HB	3/8	1.66	0.50	0.05

Nipples- Push-Lok Hose Barb



Body Size	New Part No. Steel	Old Part No.	Hose I.D.	Length	Largest Diameter	Weight (lbs.)
1/4	25SFTP06SXN	RF-254-4PL	1/4	1.69	0.50	0.04
1/4	25SFTP10SXN	RF-254-6PL	3/8	1.83	0.50	0.05



Push-to-connect sleeve, single shut off



Rectus 21, 23, 30 Series Pneumatic Quick Couplers connect with Industrial Interchange nipples, the standard male tip of the pneumatic industry. The 1/8" and 1/4" couplers have nickel plated brass construction, a corrosion resistant valve, stainless steel locking balls and a stainless steel valve spring. The 3/8" couplers have nickel plated steel construction, a corrosion resistant valve, stainless steel locking pins and a stainless steel valve spring.

Features:

- Integral sleeve guard protects against accidental disconnection
- Push-to-connect operation
- Slim profile
- Optional heavy duty version in solid steel

Applications include:

- Air compressors
- Pneumatic tools
- Drop-down air lines

Performance

Rectus 21, 23, 30 Series (1/8" & 1/4" sizes)

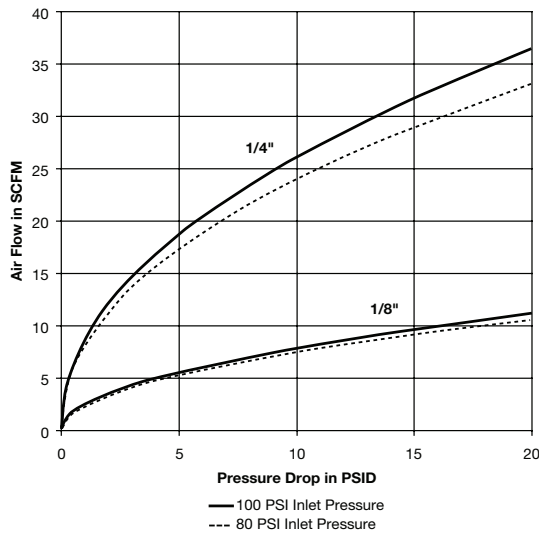

Rectus 21, 23, 30 Series (3/8" sizes)

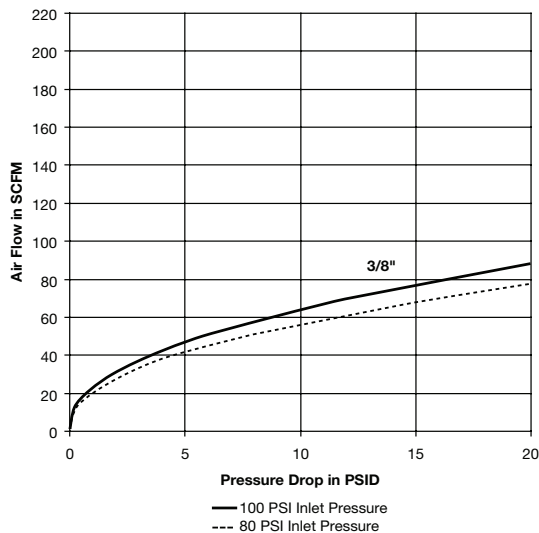

HF Series Specifications

Body Size	1/8	1/4	3/8
Rated Pressure (psi)	250	300	300
Temperature Range (std seals)	-4° to +212° F		
Locking Device	5 balls	4 balls	6 balls
Force required to connect (lbs.)	Less than 10		
Vacuum Data (in. Hg.)			
Disconnected (coupler only)	Not Recommended		
Connected	—	27.4	27.4





1/8" Body Size Couplers - Female Pipe Thread



Body Size	New Part No. Brass	Old Part No. Brass	Thread Size	Length	Largest Diameter	Wrench Flats	Weight (lbs.)
1/8	21KAIN10MPN	HF-121-2FP	1/8-27 NPTF	1.42	0.63	0.55	0.06
1/8	21KAIN13MPN	HF-121-4FP	1/4-18 NPTF	1.81	0.63	0.67	0.10

1/8" Body Size Couplers - Male Pipe Thread



Body Size	New Part No. Brass	Old Part No. Brass	Thread Size	Length	Largest Diameter	Wrench Flats	Weight (lbs.)
1/8	21KAAN10MPN	HF-121-2MP	1/8-27 NPTF	1.50	0.63	0.55	0.06
1/8	21KAAN13MPN	HF-121-4MP	1/4-18 NPTF	1.61	0.63	0.55	0.07

1/8" Body Size Nipples - Female Pipe Thread



Body Size	New Part No. Brass	Old Part No. Brass	Thread Size	Length	Largest Diameter	Wrench Flats	Weight (lbs.)
1/8	21SFIN10MXN	HF-124-2FP	1/8-27 NPTF	1.08	0.58	0.50	0.03
1/8	21SFIN13MXN	HF-124-4FP	1/4-18 NPTF	1.34	0.78	0.67	0.07

1/8" Body Size Nipples - Male Pipe Thread



Body Size	New Part No. Brass	Old Part No. Brass	Thread Size	Length	Largest Diameter	Wrench Flats	Weight (lbs.)
1/8	21SFAN10MXN	HF-124-2MP	1/8-27 NPTF	1.06	0.51	0.44	0.03
1/8	21SFAN13MXN	HF-124-4MP	1/4-18 NPTF	1.25	0.63	0.56	0.05



Push-to-connect sleeve, single shut off

1/4, 3/8" Body Size Couplers - Female Pipe Thread



Body Size	New Part No. Nickel Plated Brass	New Part No. Nickel Plated Steel	Old Part No. Brass	Thread Size	Length	Largest Diameter	Wrench Flats	Weight (lbs.)
1/4	23KAIN13MPN	-	HF-251-4FP	1/4-18 NPSF	2.19	0.99	0.81	0.26
1/4	23KAIN17MPN	-	HF-251-6FP	3/8-18 NPSF	2.34	0.99	0.81	0.27
3/8	-	30KAIN13SPN	HF-371-4FP	1/4-18 NPSF	2.33	1.07	0.94	0.33
3/8	-	30KAIN17SPN	HF-371-6FP	3/8-18 NPSF	2.33	1.07	0.94	0.31
3/8	-	30KAIN21SPN	HF-371-8FP	1/2-14 NPTF	2.49	1.07	1.00	0.35

1/4, 3/8" Body Size Couplers - Male Pipe Thread



Body Size	New Part No. Nickel Plated Brass	New Part No. Nickel Plated Steel	Old Part No. Brass	Thread Size	Length	Largest Diameter	Wrench Flats	Weight (lbs.)
1/4	23KAAN13MPN	-	HF-251-4MP	1/4-18 NPTF	2.34	0.99	0.81	0.25
1/4	23KAAN17MPN	-	HF-251-6MP	3/8-18 NPTF	2.37	0.99	0.81	0.26
3/8	-	30KAAN13SPN	HF-371-4MP	1/4-18 NPTF	2.49	1.07	0.94	0.32
3/8	-	30KAAN17SPN	HF-371-6MP	3/8-18 NPTF	2.52	1.07	0.94	0.3
3/8	-	30KAAN21SPN	HF-371-8MP	1/2-14 NPTF	2.68	1.07	0.94	0.33

1/4, 3/8" Body Size Couplers - Standard Hose Barb



Body Size	New Part No. Nickel Plated Brass	New Part No. Nickel Plated Steel	Old Part No. Brass	Hose I.D.	Length	Largest Diameter	Wrench Flats	Weight (lbs.)
1/4	23KATF06MPN	-	HF-251-4HB	1/4	2.81	0.99	0.81	0.26
1/4	23KATF09MPN	-	HF-251-6HB	3/8	2.81	0.99	0.81	0.27
3/8	-	30KATF10SPN	HF-371-6HB	3/8	3.02	1.07	0.94	0.31
3/8	-	30KAAN21SPN	HF-371-8HB	1/2	3.02	1.07	0.94	0.34

1/4, 3/8" Body Size Couplers - Push-Lok Hose Barb*



Body Size	New Part No. Nickel Plated Brass	New Part No. Nickel Plated Steel	Old Part No. Brass	Hose I.D.	Length	Largest Diameter	Wrench Flats	Weight (lbs.)
1/4	23KATP06MPN	-	HF-251-4PL	1/4	2.64	0.99	0.81	0.26
1/4	23KATP10MPN	-	HF-251-6PL	3/8	2.78	0.99	0.81	0.27
3/8	-	30KATP10SPN	HF-371-6PL	3/8	3.02	1.07	0.94	0.33
3/8	-	30KATP13SPN	HF-371-8PL	1/2	3.07	1.07	0.94	0.31

* Push-Lok hose barbs are designed for use with Parker Push-Lok hose and do not require clamps.



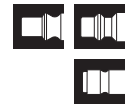

UC Series Pneumatic Quick Couplers connect with Industrial Interchange, 10 series (Tru-Flate), and 50 series (ARO 210) style nipples. While the best performance is obtained by matching like series couplers and nipples, the Universal Coupler permits multiple series nipples to mate with one coupler.

Features:

- Sleeve guard protects against accidental disconnection
- Push-to-connect operation
- Brass construction
- One coupler connects with three nipple styles

Applications include:

- Air compressors
- Pneumatic tools
- Drop-down air lines

Performance

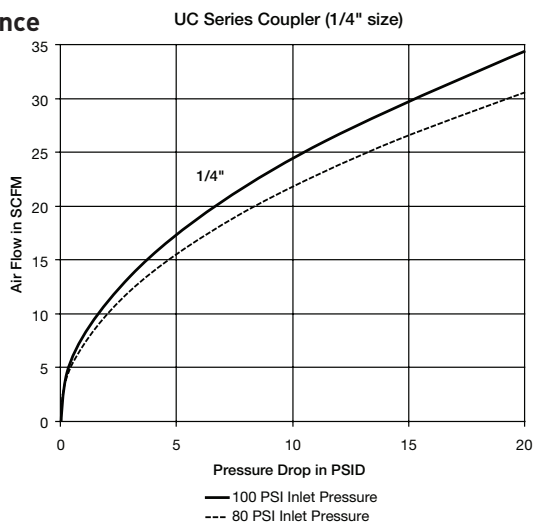

UC Series Specifications

Body Size	Rated Pressure (psi)	Temperature Range (Nitrile seats)	Locking Device	Vacuum Service
1/4	150	-40° to +250° F	4 balls	Not Recommended

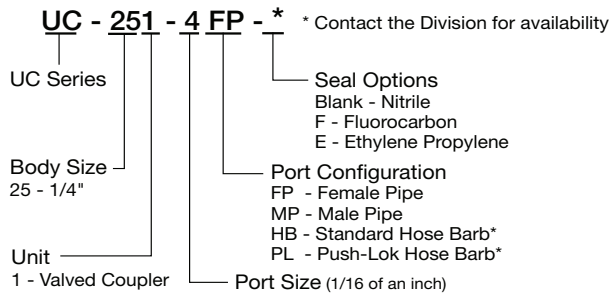

Couplers - Female Pipe Thread



Body Size	Part No. Brass	Port End	Length	Largest Diameter	Wrench Flats	Weight (lbs.)
1/4	UC-251-4FP	1/4-18 NPSF	2.06	0.98	0.81	0.23
1/4	UC-251-6FP	3/8-18 NPSF	2.21	0.98	0.81	0.23

Couplers - Male Pipe Thread



Body Size	Part No. Brass	Port End	Length	Largest Diameter	Wrench Flats	Weight (lbs.)
1/4	UC-251-4MP	1/4-18 NPTF	2.21	0.81	0.98	0.22
1/4	UC-251-6MP	3/8-18 NPTF	2.24	0.81	0.9	0.23



Performance

E-z-mate Series (1/4" & 3/8" sizes)

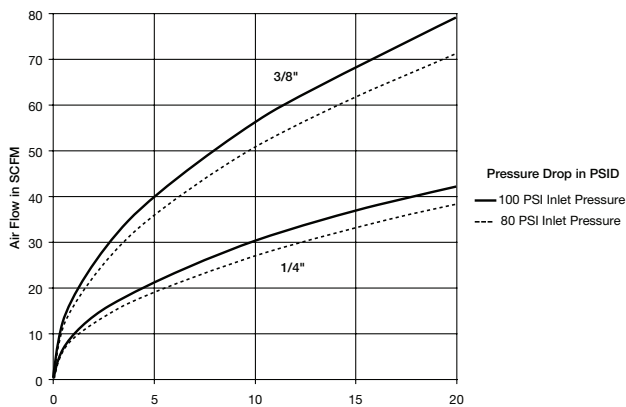

E-z-mate Series (1/2" & 3/4" sizes)

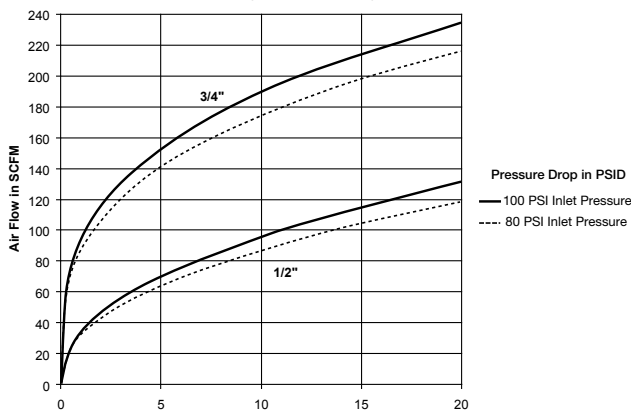

E-z-mate Series are exhaust type quick couplers that are designed to safely relieve air pressure prior to disconnection. When the locking sleeve is moved to shut off air flow, it automatically vents downstream allowing for disconnection at zero pressure and eliminating the risk of "hose whip".

Features:

- Self-locking valve sleeve protects against accidental disconnection
- Push-to-connect operation
- Meets ISO 4414 requirements for a controlled pressure release system

Applications include:

- Pneumatic tools
- Drop-down air lines

Operation

Parker E-z-mate couplings combine push-to-connect, exhaust-style action with a self-locking valve sleeve to guard against accidental disconnection. Simply follow the direction of the On-Off arrow stamped on the valve sleeve. It's that easy.

To connect, push the nipple into the coupler. The black locking sleeve automatically slides forward securely locking the nipple in place. No air is allowed to flow through the coupling at this point. The valve sleeve is then rotated clockwise (when viewed from the coupler port end) to open flow and automatically engage the sleeve-lock mechanism.

To disconnect, rotate the valve sleeve counter clockwise (when viewed from the coupler end). The flow of air through the coupling will be shut off and all downstream air is vented to the atmosphere. The locking sleeve may now be retracted and the nipple removed. Lubricate sleeve as part of periodic maintenance to coupler.

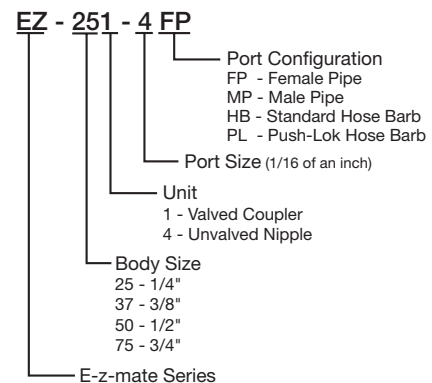

E-z mate Series Specifications				
Body Size	1/4	3/8	1/2	3/4
Rated Pressure (psi)	300			
Temperature Range (std seals)	-40° to +250° F			
Locking Device	4 balls	4 balls	6 balls	8 balls
Force required to connect (lbs.)	Less than 10			
Vacuum Service	Not Recommended			



Couplers - Female Pipe Thread



Body Size	Part No. Steel	Port End	Length	Largest Diameter	Wrench Flats	Weight (lbs.)
1/4	EZ-251-4FP	1/4-18 NPTF	2.25	1.00	0.75	0.25
1/4	EZ-251-6FP	3/8-18 NPTF	2.68	1.01	0.88	0.29
3/8	EZ-371-6FP	3/8-18 NPTF	2.53	1.18	0.88	0.38
3/8	EZ-371-8FP	1/2-14 NPTF	3.00	1.30	1.12	0.50
1/2	EZ-501-8FP	1/2-14 NPTF	3.01	1.38	1.12	0.65
1/2	EZ-501-12FP	3/4-14 NPTF	3.44	1.59	1.38	0.70
3/4	EZ-751-12FP	3/4-14 NPTF	3.01	1.57	1.38	0.76
3/4	EZ-751-16FP	1-11 1/2 NPTF	3.52	1.80	1.56	0.92

Couplers - Male Pipe Thread



Body Size	Part No. Steel	Port End	Length	Largest Diameter	Wrench Flats	Weight (lbs.)
1/4	EZ-251-4MP	1/4-18 NPTF	2.85	1.00	0.75	0.30
1/4	EZ-251-6MP	3/8-18 NPTF	2.87	1.00	0.75	0.31
3/8	EZ-371-6MP	3/8-18 NPTF	3.10	1.18	0.88	0.44
1/2	EZ-501-8MP	1/2-14 NPTF	3.62	1.38	1.12	0.73
3/4	EZ-751-12MP	3/4-14 NPTF	4.04	1.57	1.38	0.90

Couplers - Standard Hose Barb



Body Size	Part No. Steel	Hose I.D.	Length	Largest Diameter	Wrench Flats	Weight (lbs.)
1/4	EZ-251-4HB	1/4	3.20	1.00	0.75	0.28
1/4	EZ-251-6HB	3/8	3.20	1.00	0.75	0.29
3/8	EZ-371-6HB	3/8	3.43	1.18	0.88	0.42
1/2	EZ-501-8HB	1/2	4.06	1.40	1.12	0.70

Couplers - Push-Lok Hose Barb*



Body Size	Part No. Steel	Hose I.D.	Length	Largest Diameter	Wrench Flats	Weight (lbs.)
1/4	EZ-251-4PL	1/4	3.03	1.00	0.75	0.28
1/4	EZ-251-6PL	3/8	3.18	1.00	0.75	0.29
3/8	EZ-371-6PL	3/8	3.38	1.18	0.88	0.42
1/2	EZ-501-8PL	1/2	3.91	1.38	1.12	0.70

* Push-Lok hose barbs are designed for use with Parker Push-Lok hose and do not require clamps.

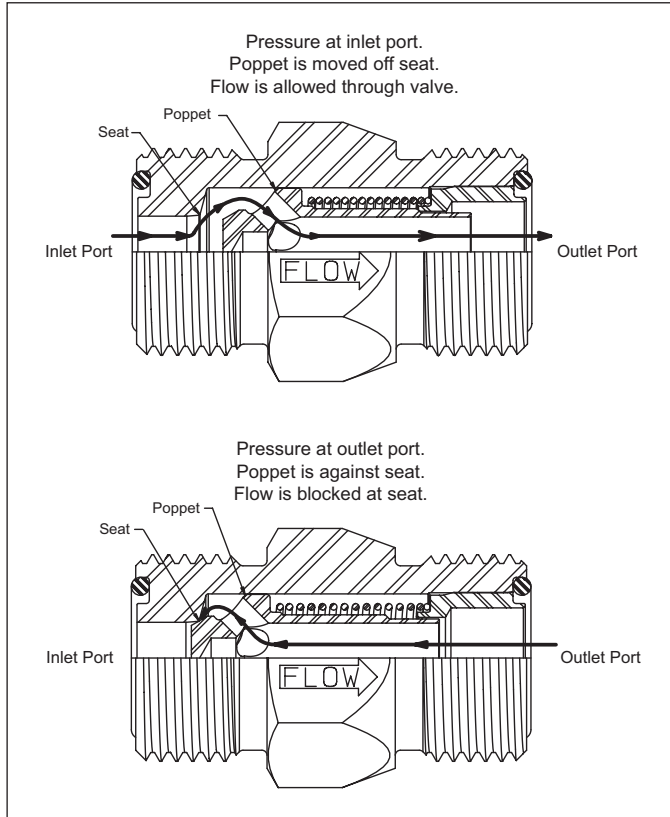
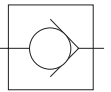

Features

Parker's Check Valves employ several unique features that insure years of trouble-free operation.

Crack Pressure

Crack pressure refers to the amount of fluid pressure in the free flow direction required to move the poppet off the seat. The normal crack pressure setting is 5 PSI; however, other crack pressures are available to allow the check valve to perform special circuit functions, or operate under unique conditions.

Check valves are not field repairable or adjustable. Crack pressure settings are made at the factory only.

Specifications				
Series	Body Size (in.)	Material	Rated Pressure (psi)	Crack Pressure Range (psi)
DT Series	1/4 - 1 1/4	Steel	5000	5-200

DT Series Pressure Table (psi)				
Body Size	Max Rated Pressure	MF (Male JIC 37)	MO (SAE O-Ring Boss)	MS (Male Seal-Lok)
1/4	5000	5000	5000	5000
3/8	5000	5000	5000	5000
1/2	5000	4500	5000	5000
5/8	5000	3500	5000	5000
3/4	5000	3500	5000	5000
1	5000	3000	5000	5000
1 1/4	4000	2500	4000	4000

Applications

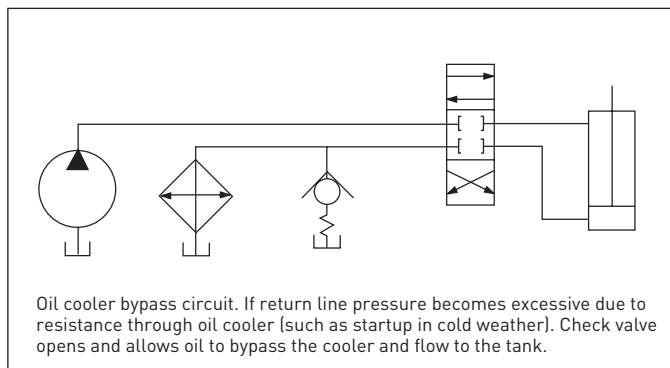
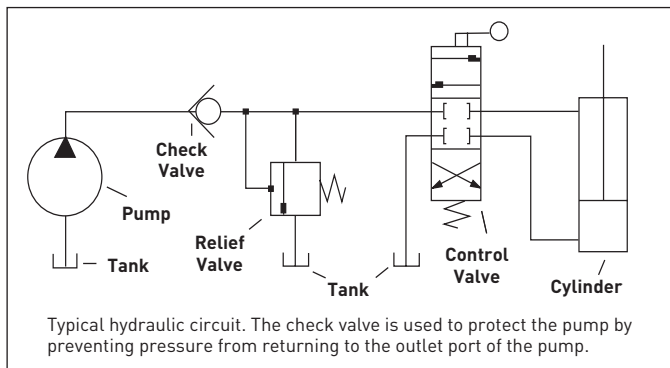

DT Series Installation Assembly Torque (ft-lbs)			
Body Size	MF (Male JIC 37)	MO (SAE O-Ring Boss)	MS (Male Seal-Lok)
1/4	Refer to Parker TFD Catalog 4300 for torque recommendation	13.3 +10% / -0%	Refer to Parker TFD Catalog 4300 for torque recommendation
3/8		22.1 +10% / -0%	
1/2		62.6 +10% / -0%	
5/8		84.8 +10% / -0%	
3/4		125.3 +10% / -0%	
1		199 +10% / -0%	
1 1/4		210 +10% / -0%	



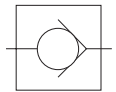

Parker DT Series Check Valves Offer the Features of a Compact Body Size, and 5000 PSI Maximum Operating Pressure

The DT Series check valves utilize the dependable, internal design features found in Parker check valves, but with the added benefit and convenience of compact design. Sizes are available from 1/4" to 1-1/4" with six different Fitting Styles.

The DT Series expands Parker's high quality product line of versatile and efficient check valves.



Features

1. Compact Design. Easy to plumb into tight circuits.
2. All steel construction. No internal gaskets or seals to wear out.
3. One-piece body eliminates threads and seals that may be potential leakage points.
4. Smooth flow stream. Poppet spring is isolated from flow stream.
5. Variety of end fittings.
6. Optional crack pressures available from 1 to 200 PSI.
7. Chromium-6 Free plated exterior finish.
8. Nitrile O-Ring included on MO and MS fittings.
9. Captive O-Ring Groove is standard on MS end fittings.

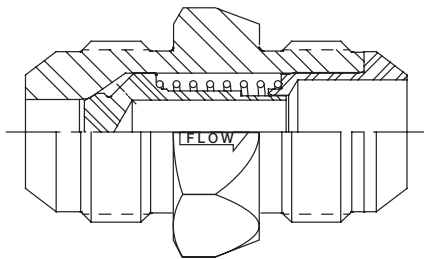

DT-MFMF

Male Flare 37° JIC Inlet to Male Flare 37° JIC Outlet

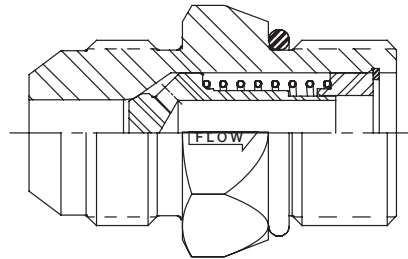

DT-MFMO

Male Flare 37° JIC Inlet to Male O-Ring Boss Outlet

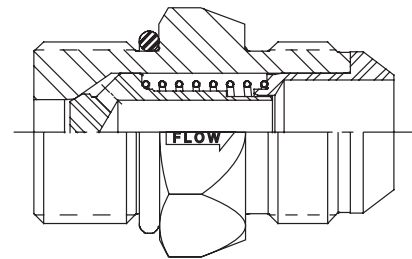

DT-MOMF

Male O-Ring Boss Inlet to Male Flare 37° JIC Outlet

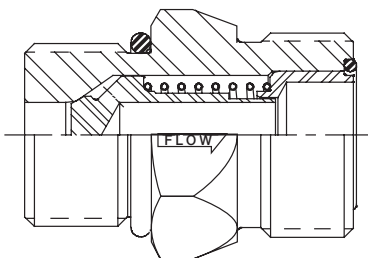

DT-MOMS

Male O-Ring Boss Inlet to Male Seal-Lok® Outlet

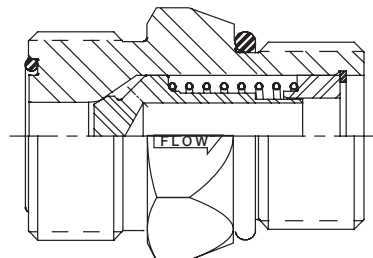

DT-MSMO

Male Seal-Lok® Inlet to Male O-Ring Boss Outlet

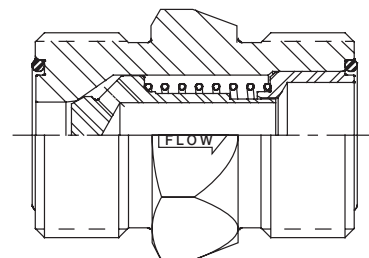

DT-MSMS

Male Seal-Lok® Inlet to Male Seal-Lok® Outlet

Flow Control / Check Valves

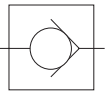

DT-MFMF Male Flare 37° JIC Inlet to Male Flare 37° JIC Outlet



Body Size	Part Number	Inlet Port End	Outlet Port End	Inlet Port Length	Hex	Outlet Port Length	Wrench Flats	Standard Crack Pressure (psi)
3/8	DT-370-MFMF-**	9/16-18 UNF	9/16-18 UNF	0.56	0.44	0.56	0.75	1, 5, 65
1/2	DT-500-MFMF-**	3/4-16 UNF	3/4-16 UNF	0.66	0.50	0.66	0.88	5, 65
5/8	DT-620-MFMF-**	7/8-14 UNF	7/8-14 UNF	0.76	0.50	0.76	1.06	5
3/4	DT-750-MFMF-**	1-1/16- 12 UN	1-1/16- 12 UN	0.86	0.50	0.86	1.25	1, 5, 65
1	DT-1000-MFMF-**	1-5/16- 12 UN	1-5/16- 12 UN	0.91	0.62	0.91	1.50	5, 65
1 1/4	DT-1250-MFMF-**	1-5/8 - 12 UN	1-5/8 - 12 UN	0.96	1.06	0.96	1.88	1, 5 psi

DT-MFMO Male Flare 37° JIC Inlet to Male O-Ring Boss Outlet



Body Size	Part Number	Inlet Port End	Outlet Port End	Inlet Port Length	Hex	Outlet Port Length	Wrench Flats	Standard Crack Pressure (psi)
1/4	DT-250-MFMO-**	7/16-20 UNF	0.55	0.44	0.43	7/16-20 UNF	0.62	5
3/8	DT-370-MFMO-**	9/16-18 UNF	0.56	0.44	0.47	9/16-18 UNF	0.75	1, 5, 65
1/2	DT-500-MFMO-**	3/4-16 UNF	0.66	0.50	0.55	3/4-16 UNF	0.88	5, 65
5/8	DT-620-MFMO-**	7/8-14 UNF	0.76	0.50	0.63	7/8-14 UNF	1.06	5
3/4	DT-750-MFMO-**	1-1/16 - 12 UN	0.86	0.50	0.73	1-1/16 - 12 UN	1.25	1, 5, 65
1	DT-1000-MFMO-**	1-5/16 - 12 UN	0.91	0.62	0.73	1-5/16 - 12 UN	1.50	5, 65
1 1/4	DT-1250-MFMO-**	1-5/8 - 12 UN	0.96	1.06	0.73	1-5/8 - 12 UN	1.88	1, 5

DT-MOMF Male O-Ring Boss Inlet to Male Flare 37° JIC Outlet



Body Size	Part Number	Inlet Port End	Outlet Port End	Inlet Port Length	Hex	Outlet Port Length	Wrench Flats	Standard Crack Pressure (psi)
1/4	DT-250-MOMF-**	7/16-20 UNF	0.43	0.44	0.55	7/16-20 UNF	0.62	5
3/8	DT-370-MOMF-**	9/16-18 UNF	0.47	0.44	0.56	9/16-18 UNF	0.75	1, 5, 65
1/2	DT-500-MOMF-**	3/4-16 UNF	0.55	0.5	0.66	3/4-16 UNF	0.88	5, 65
5/8	DT-620-MOMF-**	7/8-14 UNF	0.63	0.5	0.76	7/8-14 UNF	1.06	5
3/4	DT-750-MOMF-**	1-1/16 - 12 UN	0.73	0.5	0.86	1-1/16 - 12 UN	1.25	1, 5, 65
1	DT-1000-MOMF-**	1-5/16 - 12 UN	0.73	0.62	0.91	1-5/16 - 12 UN	1.5	5, 65
1 1/4	DT-1250-MOMF-**	1-5/8 - 12 UN	0.73	1.06	0.96	1-5/8 - 12 UN	1.88	1, 5

1/8"	1/4"	3/8"	1/2"	5/8"	3/4"	1"	1-1/4"	1-1/2"
------	------	------	------	------	------	----	--------	--------

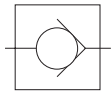

DT-MOMS Male O-Ring Boss Inlet to Male Seal-Lok® Outlet



Body Size	Part Number	Inlet Port End	Outlet Port End	Inlet Port Length	Hex	Outlet Port Length	Wrench Flats	Standard Crack Pressure (psi)
1/4	DT-250-MOMS-**	7/16-20 UNF	0.43	0.45	0.39	9/16-18 UNF	0.62	5
3/8	DT-370-MOMS-**	9/16-18 UNF	0.47	0.44	0.44	11/16-16 UN	0.75	1, 5, 65
1/2	DT-500-MOMS-**	3/4-16 UNF	0.55	0.5	0.51	13/16-16 UN	0.88	5, 65
5/8	DT-620-MOMS-**	7/8-14 UNF	0.63	0.5	0.62	1-14 UNS	1.06	5
3/4	DT-750-MOMS-**	1-1/16 - 12 UN	0.73	0.5	0.68	1-3/16 - 12 UN	1.25	1, 5, 65
1	DT-1000-MOMS-**	1-5/16 - 12 UN	0.73	0.62	0.7	1-7/16 - 12 UN	1.5	5, 65
1 1/4	DT-1250-MOMS-**	1-5/8 - 12 UN	0.73	1.06	0.7	1-11/16 - 12 UN	1.88	1, 5

DT-MSMO Male Seal-Lok® Inlet to Male O-Ring Boss Outlet



Body Size	Part Number	Inlet Port End	Outlet Port End	Inlet Port Length	Hex	Outlet Port Length	Wrench Flats	Standard Crack Pressure (psi)
3/8	DT-370-MSMO-**	11/16-16 UN	0.44	0.44	0.47	9/16-18 UNF	0.75	1, 5, 65
1/2	DT-500-MSMO-**	13/16-16 UN	0.51	0.5	0.55	3/4-16 UNF	0.88	5, 65
5/8	DT-620-MSMO-**	1-14 UNS	0.62	0.49	0.63	7/8-14 UNF	1.06	5
3/4	DT-750-MSMO-**	1-3/16 - 12 UN	0.68	0.5	0.73	1-1/16 - 12 UN	1.25	1, 5, 65
1	DT-1000-MSMO-**	1-7/16 - 12 UN	0.7	0.62	0.73	1-5/16 - 12 UN	1.5	5, 65
1 1/4	DT-1250-MSMO-**	1-11/16 - 12 UN	0.7	1.06	0.73	1-5/8 - 12 UN	1.88	1,

DT-MSMS Male Seal-Lok® Inlet to Male Seal-Lok® Outlet



Body Size	Part Number	Inlet Port End	Outlet Port End	Inlet Port Length	Hex	Outlet Port Length	Wrench Flats	Standard Crack Pressure (psi)
3/8	DT-370-MSMS-**	11/16-16 UN	0.44	0.44	0.44	11/16-16 UN	0.75	1, 5, 65
1/2	DT-500-MSMS-**	13/16-16 UN	0.51	0.5	0.51	13/16-16 UN	0.88	5, 65
5/8	DT-620-MSMS-**	1-14 UNS	0.62	0.5	0.62	1-14 UNS	1.06	5
3/4	DT-750-MSMS-**	1-3/16 - 12 UN	0.68	0.5	0.68	1-3/16 - 12 UN	1.25	1, 5, 65
1	DT-1000-MSMS-**	1-7/16 - 12 UN	0.7	0.62	0.7	1-7/16 - 12 UN	1.5	5, 65
1 1/4	DT-1250-MSMS-**	1-11/16 - 12 UN	0.7	1.06	0.7	1-11/16 - 12 UN	1.88	1, 5

Flow Control / Check Valves

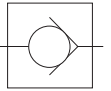

Flow Data

DT Series (1/4" & 3/8")
Test Fluid: Oil - 200 SUS

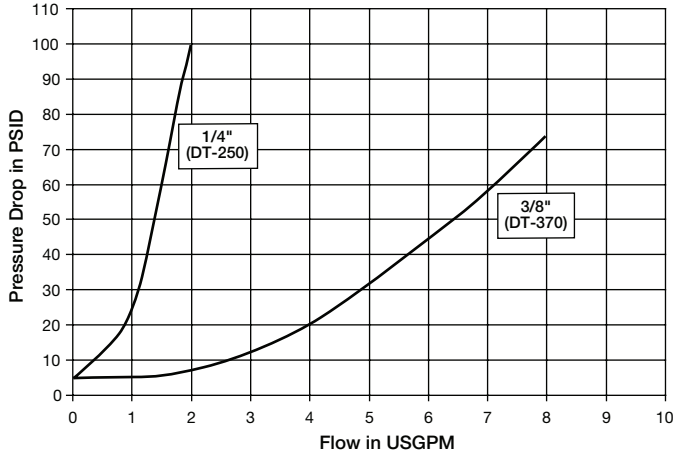

DT Series (1/2", 5/8" & 3/4")
Test Fluid: Oil - 200 SUS

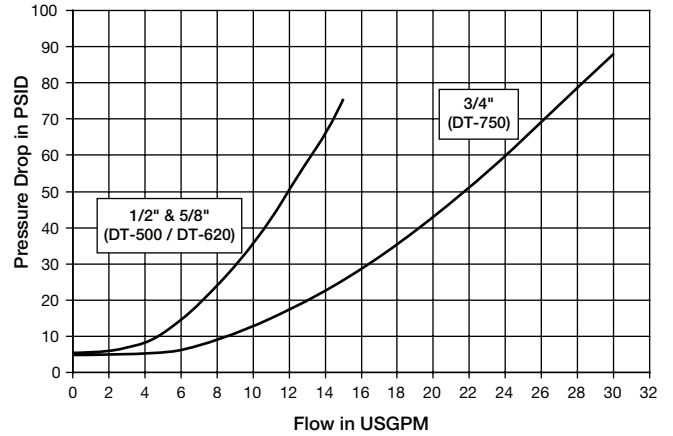

DT Series (1" & 1-1/4")
Test Fluid: Oil - 200 SUS

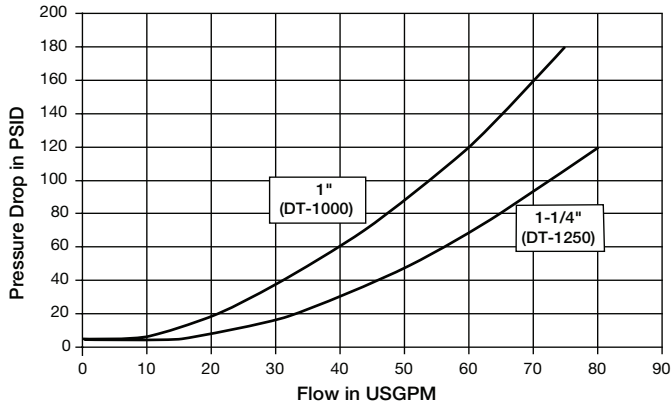

Flow Control / Check Valves

Ordering Information

DT - XXX - XXXX - XX

Series

Crack Pressure

- 1 = 1 psi
- 5 = 5 psi
- 65 = 65 psi

Other Crack Pressures up to 200 PSI in 5 PSI increments are available. Contact the Division for price and delivery on non-standard crack pressures.

Size	Series
1/4"	250
3/8"	370
1/2"	500
5/8"	620
3/4"	750
1"	1000
1 1/4"	1250

Fitting Style	
MFMF	Male Flare Inlet to Male Flare Outlet
MFMO	Male Flare Inlet to Male O-Ring Boss Outlet
MOMF	Male O-Ring Boss Inlet to Male Flare Outlet
MOMS	Male O-Ring Boss Inlet to Male Face Seal Outlet
MSMO	Male Face Seal Inlet to Male O-Ring Boss Outlet
MSMS	Male Face Seal Inlet to Male Face Seal Outlet





SAFETY GUIDE FOR SELECTING AND USING QUICK COUPLING DIVISION PRODUCTS AND RELATED ACCESSORIES



DANGER: Failure or improper selection or improper use of Quick Coupling Division (QCD) products and related accessories can cause death, personal injury, and property damage. Possible consequences of failure or improper selection or improper use of QCD products or related accessories include but are not limited to:

- Couplings or parts thrown off at high speed.
- High velocity fluid discharge.
- Explosion or burning of the conveyed fluid.
- Contact with suddenly moving or falling objects that are to be held in position or moved by the conveyed fluid.
- Dangerously whipping hose.
- Contact with conveyed fluids that may be hot, cold, toxic, or otherwise injurious.
- Sparking or explosion while paint or flammable liquid spraying.

Before selecting or using any Parker quick action couplings or related accessories, it is important that you read and follow the following instructions.

No product from the Quick Coupling Division is approved for in-flight aerospace applications. For products used in in-flight aerospace applications, please contact Parker Aerospace Group.

1.1 Scope: This safety guide provides instructions for selecting and using (including installing, connecting, disconnecting, and maintaining) QCD products and related accessories. This safety guide is a supplement to and is to be used with, the specific Parker publications for the specific QCD products and related accessories being considered for use.

1.2 Fail-Safe: QCD products or the hose they are attached to can fail without warning for many reasons. Design all systems and equipment in a fail-safe mode, so failure of the QCD product or hose will not endanger persons or property.

1.3 Distribution: Provide a copy of this safety guide to each person responsible for selecting or using QCD products. Do not select or use QCD products without thoroughly reading and understanding this safety guide as well as the specific Parker publications for the products considered or selected.

1.4 User Responsibility: Due to the wide variety of operating conditions and uses for QCD products, Parker and its distributors do not represent or warrant any particular QCD product suitable for any specific end use system. This safety guide does not analyze all technical parameters that must be considered in selecting a product. The user, through its own analysis and testing, is solely responsible for:

- Making the final selection of QCD products.
- Assuring the user's requirements are met and the use presents no health or safety hazards.
- Providing all appropriate health and safety warnings on the equipment on which the QCD products are used.

1.5 Additional Questions: Call the appropriate Parker customer service department if you have any questions or require any additional information. For the telephone numbers of the appropriate customer service department, see the Parker publication for the product being considered or used.

2.0 QCD PRODUCT SELECTION INSTRUCTIONS

2.1 Pressure: QCD product selection must be made so the published rated pressure is equal to or greater than the maximum system pressure. Surge pressures in the system higher than the rated pressure will shorten the QCD products' life. Do not confuse burst pressure or other pressure values with rated pressure and do not use burst pressure or other pressure values for this purpose.

2.2 Fluid Compatibility: QCD product selection must assure compatibility of the products' materials of construction with the fluid media being used.

2.3 Temperature: Be certain fluid and ambient temperatures, both steady and transient, do not exceed the limitations of the QCD product. Use caution and proper PPE when handling QCD products heated or cooled by the media they are conducting or by their environment.

2.4 Size: Transmission of power by means of pressurized liquid varies with pressure and flow. The size of the QCD product and other components of the system must be adequate pressure losses to a minimum and avoid damage due to heat generation or excessive fluid velocity.

2.5 Pressurized Connect or Disconnect: If connecting or disconnecting under pressure is a requirement, use only quick couplings designed for that purpose. The rated operating pressure of a quick action coupling may not be the pressure at which it may be safely connected or disconnected.

2.6 Environment: Care must be taken to ensure QCD products are either compatible with or protected from the environment (that is, surrounding conditions) to which they are exposed. Environmental conditions including but not limited to ultraviolet radiation, ozone, moisture, water, salt water, chemicals, and air pollutants can cause degradation and premature failure.

2.7 Locking Means: Ball locking quick couplings can unintentionally disconnect if they are dragged over obstructions on the end of a hose or if the sleeve is bumped or moved enough to cause disconnect. Sleeves designed with flanges to provide better ripping for oily or gloved hands are especially susceptible to accidental disconnect and should not be used where these conditions exist. Sleeve lock or union (threaded) sleeve designs should be considered where there is a potential for accidental disconnect.

2.8 Mechanical Loads: External forces can significantly reduce QCD product life or cause failure. Mechanical loads which must be considered include excessive tensile or side loads, and vibration. Unusual applications may require special testing prior to QCD product selection.



SAFETY GUIDE FOR SELECTING AND USING QUICK COUPLING DIVISION PRODUCTS AND RELATED ACCESSORIES



2.9 Specifications and Standards: When selecting QCD products, government, industry, and Parker specifications must be reviewed and followed where applicable.

2.10 Vacuum: Not all QCD products are suitable or recommended for vacuum service. QCD products used for vacuum applications must be selected to ensure the product will withstand the vacuum and pressure of the system.

2.11 Fire Resistant Fluids: Some fire-resistant fluids require seals other than the standard nitrile used in many QCD products.

2.12 Radiant Heat: QCD product can be heated to destruction or loss of sealing integrity without contact by nearby items such as hot manifolds or molten metal. The same heat source may then initiate a fire. This can occur despite the presence of cool air around the QCD product.

2.13 Welding and Brazing: Heating of plated parts, including QCD products and port adapters, above 450°F (232°C) such as during welding, brazing, or soldering may emit deadly gases and may cause permanent product damage.

3.0 QUICK ACTION COUPLING INSTALLATION INSTRUCTIONS

3.1 Pre-Installation Inspection: Before installing a QCD product, visually inspect it and check for correct style, body material, seal material, and catalog number. Before final installation, coupling halves should be connected and disconnected with a sample of the mating half with which they will be used.

3.2 Quick Coupling Halves from Other Manufacturers: If a quick coupling assembly is made up of one Parker half and one half from another manufacturer, the lowest pressure rating of the two halves should not be exceeded.

3.3 Fitting Installation: Use a thread sealant, lubricant, or a combination of both when assembling pipe thread joints on QCD products. Be sure the sealant is compatible with the system fluid or gas. To avoid system contamination, use a liquid or paste type sealant rather than a tape style. Use the flats provided to hold QCD product when installing fittings. Do not use pipe wrenches or a vice on other parts of the product to hold it when installing or removing fittings as damage or loosening of threaded assembly joints in the product could result. Do not apply excessive torque to taper pipe threads because cracking or splitting of the female component can result.

3.4 Caps and Plugs: Use dust caps and plugs when quick couplings are not coupled to exclude dirt and contamination and to protect critical surfaces from damage.

3.5 Quick Coupling Location: Locate quick couplings where they can be reached for connect or disconnect without exposing the operator to slipping, falling, getting sprayed, or coming in contact with hot or moving parts.

3.6 Hose Whips: Use a hose whip (a short length of hose between the tool and the coupling half) instead of rigidly mounting a coupling half on hand tools or other devices. This reduces the potential for coupling damage if the tool is dropped and provides some isolation from mechanical vibration which could cause unintended disconnection.

4.0 QCD PRODUCT MAINTENANCE INSTRUCTIONS

4.1 Even with proper selection and installation, QCD product life may be significantly reduced without a maintenance program. Frequency should be determined by the severity of the application and risk potential. A maintenance program must be established and followed by the user and must include the following as a minimum:

4.2 Visual Inspection of QCD Product: Any of the following conditions require immediate shut down and replacement of the QCD product:

- Cracked, damaged, or corroded product.
- Leaks at the fitting, valve or mating seal.
- Broken mounting hardware, especially breakaway clamps.

4.3 Visual Inspection Other: The following items must be tightened, repaired or replaced as required:

- Leaking seals or port connections.
- Excess dirt buildup on the quick coupling locking mechanism or on the interface area of either coupling half
- Clamps, guards, and shields.
- System fluid level, fluid type and any air entrapment.

4.4 Functional Test: Operate the system at maximum operating pressure and check for possible malfunctions and leaks. Personnel must avoid potentially hazardous areas while testing and using the system.

4.5 Replacement Intervals: Specific replacement intervals must be considered based on previous service life, government, or industry recommendations, or when failures could result in unacceptable downtime, damage, or injury risk. See instruction 1.2 above.

Additional copies of the preceding safety information can be ordered by requesting "Safety Guide for Selecting and Using QCD Product and Related Accessories," Parker Publication DS6013.

Contact Parker's Quick Coupling Division, Minneapolis, MN.

Fluid Compatibility Chart

Codes

The following seal compound and body material compatibility chart is provided as an aid in selecting a specific synthetic rubber compound or body material for a particular application. Operating and environmental conditions must be considered when making the selection of a quick coupling.

Refer to the appropriate section of the catalog for Ordering Information for Seal Codes for specific products.

To indicate a special material just add the appropriate code letter as a suffix to the catalog number of the coupler.

It is not necessary to use the code "STD" as the standard Nitrile seal will be used when another code is not used.

For recommendations for media not listed below, please contact your Parker representative or the factory.

Note

This chart is intended as a guide only and is not be considered as a recommendation to use Parker quick action couplings in a specific application or with a specific fluid, other factors that must be considered include but are not limited to: fluid and ambient temperature, system pressure, both operating and peak, frequency of connect and disconnect, and applicable standards or regulations.

CODES: 1 = Satisfactory 2 = Fair 3 = Not Recommended 4 = Insufficient Data Available

MEDIA	BODY MATERIAL				SEAL MATERIAL			
	Brass	Steel	316 S.S.	303 S.S.	Nitrile	E.P.	Fluorocarbon	Neoprene
3M FC-75	4	4	4	4	1	1	2	1
ACETAMIDE	4	4	1	2	1	1	3	1
ACETIC ACID (5%)	3	3	1	1	2	1	1	1
ACETONE	1	2	1	1	3	1	3	3
ACETOPHENONE	2	2	2	1	3	1	3	3
ACETYL ACETONE	2	2	2	2	3	1	3	3
ACETYL CHLORIDE	4	2	2	2	3	3	1	3
ACETYLENE	3	2	1	1	1	1	1	2
AIR (200 DEGREES F.)	1	2	1	1	1	1	1	1
AIR (300 DEGREES F.)	1	2	1	1	2	2	1	2
AIR (400 DEGREES F.)	1	2	1	1	3	3	1	3
ALUMINUM ACETATE	4	4	4	4	2	1	3	2
ALUMINUM BROMIDE	4	4	4	4	1	1	1	1
ALUMINUM CHLORIDE (10%)	3	3	3	3	1	1	1	1
ALUMINUM CHLORIDE (100%)	3	2	2	2	1	1	1	1
ALUMINUM FLOURIDE	3	3	3	3	1	1	1	1
ALUMINUM NITRATE	3	3	2	2	1	1	1	1
ALUMINUM SALTS	4	4	4	4	1	1	1	1
ALUMINUM SULPHATE	2	3	2	3	1	1	1	1
ALUMS (NH ₃ ,Cr,K)	4	4	4	4	1	1	3	1
AMMONIA (ANHYDROUS)	3	2	1	1	2	1	3	1
AMMONIA (COLD, GAS)	3	2	4	1	1	1	3	1
AMMONIA (HOT, GAS)	3	2	4	1	3	2	3	2
AMMONIUM CARBONATE	3	2	3	3	3	1	1	1
AMMONIUM CHLORIDE	3	3	2	3	1	1	1	1
AMMONIUM HYDROXIDE	3	3	1	2	3	1	3	1
AMMONIUM NITRATE	3	3	1	1	1	1	4	1
AMMONIUM PERSULFATE SOLUTION	3	3	1	2	3	1	4	4
AMMONIUM PHOSPHATE (MONO-, DI-, TRI-BASIC)	3	3	3	2	1	1	4	1
AMMONIUM SALTS	4	4	4	4	1	1	3	1
AMMONIUM SULFATE	3	3	2	3	1	1	3	1
AMYL BORATE	4	4	4	4	1	3	1	1
AMYL CHLORIDE	4	2	1	1	4	3	1	3
AMYL CHLORONAPHTHALENE	4	4	4	4	3	3	1	3
AMYL NAPHTHALENE	4	4	4	4	3	3	1	3
ANIMAL OIL (LARD OIL)	2	2	2	2	1	2	1	2
AROCLOR 1248	2	3	3	3	3	2	1	3
AROCLOR 1254	2	3	3	3	3	2	1	3
AROCLOR 1260	2	3	3	3	1	4	1	1
AROMATIC FUEL (50%)	4	4	4	4	2	3	1	3
ARSENIC ACID	3	3	1	1	1	1	1	1
ASPHALT	3	3	1	1	2	3	1	2
ASTM OIL, NO. 1	1	1	1	1	1	3	1	1
ASTM OIL, NO. 2	1	1	1	1	1	3	1	2

Fluid Compatibility Chart

CODES: 1 = Satisfactory 2 = Fair 3 = Not Recommended 4 = Insufficient Data Available

MEDIA	BODY MATERIAL				SEAL MATERIAL			
	Brass	Steel	316 S.S.	303 S.S.	Nitrile	E.P.	Fluorocarbon	Neoprene
ASTM OIL, NO. 3	1	1	1	1	1	3	1	3
ASTM OIL, NO. 4	1	1	1	1	2	3	1	3
ASTM REFERENCE FUEL A	3	2	1	1	1	3	1	2
ASTM REFERENCE FUEL B	3	2	1	1	1	3	1	3
ASTM REFERENCE FUEL C	3	2	1	1	2	3	1	3
AUTOMOTIVE BRAKE FLUID	4	4	4	4	3	1	3	2
BARIUM CHLORIDE	3	3	2	3	1	1	1	1
BARIUM HYDROXIDE	3	2	2	3	1	1	1	1
BARIUM SALTS	4	4	4	4	1	1	1	1
BARIUM SULFIDE	3	2	3	3	1	1	1	1
BEER	3	3	1	1	1	1	1	1
BEET SUGAR LIQUORS	3	3	1	1	1	1	1	2
BENZALDEHYDE	3	3	2	3	3	1	3	3
BENZENE	3	2	3	3	3	3	1	3
BENZENESULFONIC ACID (10%)	3	3	3	3	3	3	1	2
BENZINE	4	4	4	4	1	3	1	2
BENZOIC ACID	3	3	3	3	3	3	1	3
BENZYL ALCOHOL	4	3	1	2	3	2	1	2
BENZYL CHLORIDE	3	3	2	3	3	3	1	3
BLEACH LIQUOR	4	4	4	4	3	1	1	2
BORAX	3	2	3	3	2	1	1	3
BORDEAUX MIXTURE	4	4	4	4	2	1	1	2
BORIC ACID	3	3	2	3	1	1	1	1
BRAKE FLUID (NON-PETROLEUM)	4	4	4	4	3	1	3	2
BRINE (SODIUM CHLORIDE)	3	3	1	1	1	1	1	1
BROMINE	4	4	4	4	3	3	1	3
BROMINE WATER	4	4	4	4	3	2	1	3
BUNKER OIL	4	4	4	4	1	3	1	3
BUTADIENE (MONOMER)	3	2	1	2	3	3	1	3
BUTANE	3	1	1	1	1	3	1	1
BUTANE (2,2, & 2,3-DIMETHYL)	4	4	4	4	1	3	1	2
BUTANOL (BUTYL ALCOHOL)	2	1	1	1	1	2	1	1
BUTTER - ANIMAL FAT	2	3	1	2	1	1	1	2
BUTYL BUTYRATE	4	4	4	4	3	1	1	3
BUTYL STEARATE	4	4	4	4	2	3	1	3
CALCINE LIQUORS	4	4	4	4	1	1	1	4
CALCIUM ACETATE	4	4	4	4	2	1	3	2
CALCIUM BISULFITE	3	3	2	3	2	1	2	2
CALCIUM CARBONATE	3	2	3	2	1	1	1	1
CALCIUM CHLORIDE	3	3	2	3	1	1	1	1
CALCIUM HYDROXIDE	3	3	2	3	1	1	1	1
CALCIUM HYPOCHLORITE	3	3	2	3	2	1	1	2
CALCIUM SALTS	4	4	4	4	1	1	1	1
CALCIUM SULFIDE	3	3	2	2	1	1	1	1
CALICHE LIQUORS	4	4	4	4	1	1	1	1
CANE SUGAR LIQUORS	4	2	1	1	1	1	1	1
CARBON BISULPHIDE	4	4	4	4	3	3	1	3
CARBON DIOXIDE	1	2	1	1	1	1	1	1
CARBON DISULFIDE	2	2	2	2	3	3	1	3
CARBON MONOXIDE	1	1	1	1	1	1	1	2
CARBON TETRACHLORIDE	2	3	1	3	2	3	1	3
CARBONIC ACID	3	3	1	2	2	1	1	1
CASTOR OIL	1	1	1	1	1	2	1	1
CELLUGUARD	4	4	4	4	1	1	1	1
CELLULUBE (NOW FYRQUEL)	4	4	4	4	3	1	1	3
CHINA WOOD OIL (TUNG OIL)	2	2	1	1	1	3	1	2
CHLORINATED SALT BRINE	4	4	4	4	3	3	1	3
CHLORINATED SOLVENTS	4	4	4	4	3	3	1	3
CHLORO BENZENE	3	3	2	3	3	3	1	3
CHLOROBUTADIENE	4	4	4	4	3	3	1	3
CHLOROFORM	3	2	2	1	3	3	1	3
CHLORPHENOL	4	4	4	4	3	3	1	3
COCONUT OIL	4	4	4	4	1	3	1	3
COPPER CHLORIDE	4	4	4	4	1	1	1	2
COPPER SALTS	4	4	4	4	1	1	1	1
COPPER SULFATE	3	3	2	3	1	1	1	1

Fluid Compatibility Chart

CODES: 1 = Satisfactory 2 = Fair 3 = Not Recommended 4 = Insufficient Data Available

MEDIA	BODY MATERIAL				SEAL MATERIAL			
	Brass	Steel	316 S.S.	303 S.S.	Nitrile	E.P.	Fluorocarbon	Neoprene
CORN OIL	2	1	1	1	1	3	1	3
COTTONSEED OIL	3	2	1	2	1	3	1	3
CREOSOLS	3	2	1	2	3	3	1	3
CREOSOTE	3	3	2	1	1	3	1	2
CRESYLIC ACID	4	2	1	2	3	3	1	3
CRUDE OIL	3	2	1	1	2	3	1	3
CUTTING OIL	4	1	1	1	1	3	1	2
DECANE	4	4	4	4	1	3	1	3
DENATURED ALCOHOL	4	4	4	4	1	1	1	1
DETERGENT, WATER SOLUTION	3	3	1	1	1	1	1	2
DIESEL FUEL	1	1	1	1	1	3	1	3
DIETHYLENE GLYCOL	3	1	1	1	1	1	1	1
DIMETHYL FORMAMIDE	4	4	1	1	2	1	3	3
DOW CHEMICAL HD50-4	4	4	4	4	4	1	3	2
DOW CORNING 200, 510, 550	4	4	4	4	2	1	1	1
DOWTHERM A,E	3	1	2	2	3	3	1	3
ETHANOL	1	3	3	3	3	1	3	1
ETHYL CHLORIDE	2	3	1	3	1	3	1	3
ETHYL HEXANOL	4	4	4	4	1	1	1	1
ETHYLENE DICHLORIDE	3	3	1	2	3	3	1	3
ETHYLENE GLYCOL	2	2	1	2	1	1	1	1
FATTY ACIDS	3	3	1	2	2	3	1	2
FREON 11	1	4	4	4	2	3	2	3
FREON 12	1	1	3	1	2	3	1	1
FREON 22	1	3	1	1	3	3	3	1
FREON 134a	1	1	1	1	2	1	4	1
FUEL OIL	3	1	1	1	1	3	1	2
GALLIC ACID	3	3	2	2	2	2	1	2
GAS, LIQUID, PROPANE (LPG)	1	3	1	1	1	3	1	2
GAS, NATURAL	2	3	1	1	1	3	1	1
GASOLINE	1	2	1	1	3	3	1	3
GELATIN	3	3	1	1	1	1	1	1
GLUCOSE	1	1	1	1	1	1	1	1
GLYCERINE (GLYCEROL)	2	1	1	1	1	1	1	1
GLYCOLS	3	2	2	2	1	1	3	1
GREEN SULFATE LIQUOR	3	3	3	3	2	1	1	2
GULF - FR FLUID (EMULSION)	4	4	4	4	1	3	1	2
GULF - FR FLUID G	4	4	4	4	1	1	1	1
GULF - FR FLUID P	4	4	4	4	3	2	2	3
HELIUM	1	1	1	1	1	1	1	1
HEPTANE	1	1	1	1	1	3	1	2
HYDRAULIC OIL (PETROLEUM BASE)	1	1	1	1	1	3	1	1
HYDRAULIC OIL (WATER BASE)	4	1	1	1	2	1	3	2
HYDRAZINE	4	3	1	1	2	1	3	2
HYDROGEN GAS	2	2	1	1	1	1	1	1
HYDROLUBE	4	4	4	4	1	1	1	2
ISO OCTANE	1	1	1	1	1	3	1	2
ISOBUTYL ALCOHOL	4	4	1	1	2	1	1	1
ISOPROPYL ALCOHOL	1	1	2	1	2	1	1	2
ISOPROPYL ETHER	1	1	1	1	2	3	3	3
JP3 AND JP4	1	1	1	1	1	3	1	3
KEROSENE	1	1	1	1	1	3	1	2
LARD, ANIMAL FAT	1	1	1	1	1	2	1	2
LINSEED OIL	3	1	1	1	1	3	1	3
LUBRICATING OIL SAE 10, 20, 30, 40, 50	1	1	1	1	1	3	1	2
MAGNESIUM SALTS	4	4	4	4	1	1	1	1
MAGNESIUM SULPHATE	3	3	2	2	1	1	1	1
MERCURY	3	3	1	1	1	1	1	1
METHANE	1	3	1	1	1	3	1	2
METHANOL	1	1	1	1	1	1	3	1
METHYL BROMIDE	4	1	1	1	2	3	1	3
METHYL CHLORIDE (DRY)	2	3	1	1	3	3	1	3
METHYL CHLORIDE (WET)	1	3	1	3	3	3	1	3
METHYL ETHER	4	4	4	4	1	3	1	3
METHYL ETHYL KETONE (MEK)	1	1	1	1	3	1	3	3
MIL-F-81912 (JP-9)	1	1	1	1	3	3	1	3

Appendix

Fluid Compatibility Chart

CODES: 1 = Satisfactory 2 = Fair 3 = Not Recommended 4 = Insufficient Data Available

MEDIA	BODY MATERIAL				SEAL MATERIAL			
	Brass	Steel	316 S.S.	303 S.S.	Nitrile	E.P. Fluorocarbon	Neoprene	
MIL-H-5606	1	1	1	1	1	3	1	2
MIL-H-6083	1	1	1	1	1	3	1	1
MIL-H-7083	1	1	1	1	1	1	2	2
MIL-H-8446 (MLO-8515)	2	1	1	1	2	3	1	1
MIL-L-2104 & 2104B	1	1	1	1	1	3	1	2
MIL-L-7808	3	2	1	1	2	3	1	3
MILK	2	1	1	1	1	1	1	1
MINERAL OILS	1	1	1	1	1	3	1	2
MLO-7277 AND MLO-7557	2	1	1	1	3	3	1	3
MOBILE HF	1	1	1	1	1	3	1	2
MONOMETHYL HYDRAZINE	4	4	4	4	2	1	4	2
NAPHTHA (COAL OR PETROLEUM)	2	1	2	2	2	3	1	3
NAPHTHALENE	2	1	2	2	3	3	1	3
NAPHTHENIC ACID	2	1	2	2	2	3	1	3
NEATSFOOT OIL	4	4	4	4	1	2	1	3
NICKEL, ACETATE	3	2	1	1	2	1	3	2
NICKEL CHLORIDE	3	3	2	2	1	1	1	2
NICKEL SALTS	4	4	4	4	1	1	1	2
NICKEL SULFATE	3	3	1	1	1	1	1	1
NITROGEN	1	1	1	1	1	1	1	1
NITROUS OXIDE	2	2	2	1	1	4	4	4
OCTYL ALCOHOL	1	1	1	1	2	3	1	2
OLIVE OIL	2	1	1	1	1	2	1	2
ORTHO-DICHLOROBENZENE	2	2	2	2	3	3	1	3
OXALIC ACID	3	3	2	1	2	1	1	2
OXYGEN (200-400 DEGREES F.)	1	1	1	1	3	3	2	3
OXYGEN, COLD	1	1	1	1	2	1	1	1
OZONE	3	3	1	1	3	1	1	3
PALMITIC ACID	1	2	1	1	1	2	1	2
PARA-DICHLOROBENZENE	2	1	1	2	3	3	1	3
PARKER O LUBE	1	1	1	1	1	3	1	1
PEANUT OIL	2	1	1	1	1	3	1	3
PENTANE (2-3-METHYL, & 2-4 DIMETHYL)	2	2	2	2	1	3	1	2
PERCHLORIC ACID -2N	3	3	2	2	3	2	1	2
PERCHLOROETHYLENE	3	2	2	2	2	3	1	3
PETROLATUM	1	1	1	1	1	3	1	2
PETROLEUM OIL, BELOW 250 DEGREES F.	1	1	1	1	1	3	1	2
PHENOL	1	1	1	1	3	3	1	3
PHOSPHORIC ACID (3 MOLAR)	3	3	2	2	1	1	1	2
PHOSPHORIC ACID (CONCENTRATED)	3	3	2	2	3	1	1	3
PHOSPHOROUS TRICHLORIDE	3	3	1	1	3	1	1	3
PICRIC ACID, MOLTEN	3	3	2	2	2	2	1	2
PICRIC ACID, WATER SOLUTION	3	3	2	2	1	1	1	1
PINE OIL	2	2	1	2	1	3	1	3
PLATING SOLUTIONS (CHROME)	1	3	1	1	4	1	1	3
PLATING SOLUTIONS (OTHER)	4	1	1	1	1	1	1	3
PNEUMATIC SERVICE	1	1	1	1	1	1	1	1
POTASSIUM ACETATE	2	1	2	2	2	1	3	2
POTASSIUM CHLORIDE	3	3	1	2	1	1	1	1
POTASSIUM CYANIDE	3	2	2	2	1	1	1	1
POTASSIUM DICHROMATE	3	1	2	2	1	1	1	1
POTASSIUM HYDROXIDE (50%)	3	2	1	2	2	1	3	2
POTASSIUM NITRATE	2	1	1	1	1	1	1	1
POTASSIUM SALTS	4	4	4	4	1	1	1	1
POTASSIUM SULFATE	3	2	1	1	1	1	1	1
PRL-HIGH TEMP. HYDR. OIL	4	4	4	4	2	3	1	2
PRODUCER GAS	2	1	1	1	1	3	1	2
PROPANE	1	3	1	1	1	3	1	2
PROPYL ACETATE	3	1	1	1	3	2	3	3
PROPYL ALCOHOL	1	1	1	1	1	1	1	1
PROPYLENE	1	1	1	1	3	3	1	3
PYDRAUL 10E	3	1	1	1	3	1	3	3
PYDRAUL A-200, C SERIES	3	1	1	1	3	3	1	3
PYDRAUL, 3 SERIES	3	1	1	1	3	1	1	3
PYROGARD 42, 43, 53, 55 (PHOSPHATE ESTER)	4	4	4	4	3	1	1	3

Fluid Compatibility Chart

CODES: 1 = Satisfactory 2 = Fair 3 = Not Recommended 4 = Insufficient Data Available

MEDIA	BODY MATERIAL				SEAL MATERIAL			
	Brass	Steel	316 S.S.	303 S.S.	Nitrile	E.P.	Fluorocarbon	Neoprene
PYROGARD D	4	4	4	4	1	3	3	2
SEA WATER (SALT WATER)	2	3	1	1	1	1	1	2
SHELL IRUS 905	4	4	4	4	1	3	1	2
SILICONE GREASES	1	1	1	1	1	1	1	1
SILVER NITRATE	3	3	1	2	2	1	1	1
SKYDROL 500, TYPE 2	3	1	1	1	3	1	3	3
SKYDROL 7000, TYPE 2	3	1	1	1	3	1	2	3
SOAP SOLUTIONS	3	3	1	1	1	1	1	2
SODIUM ACETATE	1	1	1	1	2	1	3	2
SODIUM BICARBONATE (BAKING SODA)	2	2	1	1	1	1	1	1
SODIUM BISULPHATE OR BISULPHITE	3	3	2	1	1	1	1	1
SODIUM BORATE	3	2	2	2	1	1	1	1
SODIUM CARBONATE (SODA ASH)	4	1	1	1	1	1	1	1
SODIUM CHLORIDE	3	2	2	2	1	1	1	1
SODIUM CYANIDE	3	1	1	1	1	1	4	1
SODIUM HYDROXIDE (CAUSTIC SODA, LYE)	3	2	1	2	2	1	2	2
SODIUM HYDROXIDE, 50%	3	3	1	2	2	1	2	2
SODIUM METAPHOSPHATE	2	1	2	2	1	1	1	2
SODIUM NITRATE	3	2	1	1	2	1	4	2
SODIUM PERBORATE	3	3	1	1	2	1	1	2
SODIUM PEROXIDE	3	1	2	2	2	1	1	2
SODIUM PHOSPHATES	1	3	2	1	1	1	1	2
SODIUM SALTS	4	4	4	4	1	1	1	2
SODIUM SULFATE	3	2	1	1	1	1	1	1
SODIUM SULFIDE AND SULFITE	3	3	2	3	1	1	1	1
SODIUM THIOSULFATE	3	3	1	2	2	1	1	1
SOYBEAN OIL	2	1	1	1	1	3	1	3
STANNOUS CHLORIDE (15%)	3	3	2	3	1	1	1	1
STEAM, BELOW 400 DEGREEES F.	1	3	1	1	3	1*	3	3
STODDARD SOLVENT	2	1	1	1	1	3	1	2
SUCROSE SOLUTIONS	1	1	1	1	1	1	1	2
SULFUR	2	1	1	1	3	1	1	1
SULFUR LIQUORS	1	1	1	1	2	2	1	2
SULFUR (MOLTEN)	3	3	1	1	3	3	1	3
SULFUR DIOXIDE (DRY)	3	1	1	3	3	1	3	3
SULFUR TRIOXIDE (DRY)	2	2	2	3	3	2	1	3
SUNSAFE	3	1	1	1	1	3	1	2
TANNIC ACID (10%)	1	3	2	3	1	1	1	2
TAR, BITUMINOUS	2	1	1	1	2	3	1	3
TARTARIC ACID	2	3	3	2	1	2	1	2
TERPINEOL	4	4	4	4	2	3	1	3
TERTIARY BUTYL ALCOHOL	1	1	1	1	2	2	1	2
TETRACHLOROETHANE	4	2	1	2	3	3	1	3
TETRACHLOROETHYLENE	3	2	2	4	3	3	1	3
TETRAETHYL LEAD	1	1	1	1	2	3	1	2
TETRAETHYL LEAD (BLEND)	1	1	1	1	2	3	1	3
TITANIUM TETRACHLORIDE	2	1	2	3	2	3	1	3
TOLUENE	1	1	1	1	3	3	1	3
TRANSFORMER OIL	1	1	1	1	1	3	1	2
TRANSMISSION FLUID (TYPE A)	1	1	1	1	1	3	1	2
TRICHLOROETHANE	4	2	1	4	3	3	1	3
TRICHLOROETHYLENE	3	2	2	2	3	3	1	3
TRICRESYL PHOSPHATE	4	1	2	2	3	1	2	3
TURBINE OIL #15 (MIL-L-7808A)	4	2	1	1	2	3	1	3
TURPENTINE	3	2	1	1	1	3	1	3
VARNISH	1	1	1	1	2	3	1	3
WATER	1	3	1	1	1	1	2	2
WHISKEY	1	3	1	1	1	1	1	1
WINE	1	3	1	1	1	1	1	1
WOOD OIL	4	2	1	1	1	3	1	2
XYLENE	1	2	1	1	3	3	1	3
ZINC SULFATE	3	3	2	2	1	1	1	1

Appendix

PARKER-HANNIFIN CORPORATION

OFFER OF SALE

The goods, services or work (referred to as the "Products") offered by Parker-Hannifin Corporation, its subsidiaries, groups, divisions, and authorized distributors ("Seller") are offered for sale at prices indicated in the offer, or as may be established by Seller. The offer to sell the Products and acceptance of Seller's offer by any customer ("Buyer") is contingent upon, and will be governed by all of the terms and conditions contained in this Offer of Sale. Buyer's order for any Products specified in Buyer's purchase document or Seller's offer, proposal or quote ("Quote") attached to the purchase order, when communicated to Seller verbally, or in writing, shall constitute acceptance of this offer.

1. Definitions. As used herein, the following terms have the meanings indicated.

"Buyer" means any customer receiving a Quote for Products.
"Buyer's Property" means any tools, patterns, drawings, designs, specifications materials, equipment, or information furnished by Buyer, or which are or become Buyer's property.

"Confidential Information" means any technical, commercial, or other proprietary information of Seller, including, without limitation, pricing, technical drawings or prints and/or part lists, which has been or will be disclosed, delivered, or made available, whether directly or indirectly, to Buyer.

"Goods" means any tangible part, system or component to be supplied by Seller.
"Intellectual Property Rights" means any patents, trademarks, copyrights, trade dress, trade secrets or similar rights.

"Products" means the Goods, Services and/or Software as described in a Quote.
"Quote" means the offer or proposal made by Seller to Buyer for the supply of Products.

"Seller" means Parker-Hannifin Corporation, including all divisions, subsidiaries and businesses selling Products under these Terms.

"Seller's IP" means patents, trademarks, copyrights, or other intellectual property rights relating to the Products, including without limitation, names, designs, images, drawings, models, software, templates, information, any improvements or creations or other intellectual property developed prior to or during the relationship contemplated herein.

"Services" means any services to be provided by Seller.

"Software" means any software related to the Goods, whether embedded or separately downloaded.

"Special Tooling" means equipment acquired by Seller or otherwise owned by Seller necessary to manufacture Goods, including but not limited to tools, jigs, and fixtures.

"Terms" means the terms and conditions of this Offer of Sale.

2. Terms. All sales of Products by Seller will be governed by, and are expressly conditioned upon Buyer's assent to, these Terms. These Terms are incorporated into any Quote provided by Seller to Buyer. Buyer's order for any Products whether communicated to Seller verbally, in writing, by electronic data interface or other electronic commerce, shall constitute acceptance of these Terms. Seller objects to any contrary or additional terms or conditions of Buyer. Reference in Seller's order acknowledgement to Buyer's purchase order or purchase order number shall in no way constitute an acceptance of any of Buyer's terms or conditions of purchase. Any Quote made by Seller to Buyer shall be considered a firm and definite offer and shall not be deemed to be otherwise despite any language on the face of the Quote. Seller reserves all rights to accept or reject any purported acceptance by Buyer to Seller's Quote if such purported acceptance attempts to vary the terms of the Quote. If Seller ships Products after Buyer issues an acceptance to the Quote, any additional or different terms proposed by Buyer will not become part of the parties' business relationship unless agreed to in a writing that is signed by an authorized representative of Seller, excluding email correspondence. If the transaction proceeds without such agreement on the part of Seller, the business relationship will be governed solely by these Terms and the specific terms in Seller's Quote.

3. Price; Payment. The Products set forth in the Quote are offered for sale at the prices indicated in the Quote. Unless otherwise specifically stated in the Quote, prices are valid for thirty (30) days and do not include any sales, use, or other taxes or duties. Seller reserves the right to modify prices for any reason and at any time by giving ten (10) days prior written notice. Unless otherwise specified by Seller, all prices are F.C.A. Seller's facility (INCOTERMS 2020). All sales are contingent upon credit approval and full payment for all purchases is due thirty (30) days from the date of invoice (or such date as may be specified in the Quote). Under any circumstances, Buyer may not withhold or suspend payment of any amounts due and payable as a deduction, set-off or recoupment of any amount, claim or dispute with Seller. Unpaid invoices beyond the specified payment date incur interest at the rate of 1.5% per month or the maximum allowable rate under applicable law. Seller reserves the right to require advance payment or provision of securities for first and subsequent deliveries if there is any doubt, in Seller's sole determination, regarding the Buyer's creditworthiness or for other business reasons. If the requested advance payment or securities are not provided to Seller's satisfaction, Seller reserves the right to suspend performance or reject the purchase order, in whole or in part, without prejudice to Seller's other rights or remedies, including the right to full compensation. Seller may revoke or shorten any payment periods previously granted in Seller's sole determination. The rights and remedies herein reserved to Seller are cumulative and in addition to any other or further rights and remedies available at law or in equity. No waiver by Seller of any breach by Buyer of any provision of these terms will constitute a waiver by Seller of any other breach of such provision.

4. Shipment; Delivery; Title and Risk of Loss. All delivery dates are approximate, and Seller is not responsible for damages or additional costs resulting from any delay. All deliveries are subject to our ability to procure materials from our suppliers. Regardless of the manner of shipment, delivery occurs and title and risk of loss or damage pass to Buyer, upon placement of the Products with the carrier at Seller's facility. Unless otherwise agreed prior to shipment and for domestic delivery locations only, Seller will select and arrange, at Buyer's sole expense, the carrier and means of delivery. When Seller selects and arranges

the carrier and means of delivery, freight and insurance costs for shipment to the designated delivery location will be prepaid by Seller and added as a separate line item to the invoice. Buyer shall be responsible for any additional shipping charges incurred by Seller due to Buyer's acts or omissions. Buyer shall not return or repackage any Products without the prior written authorization from Seller, and any return shall be at the sole cost and expense of Buyer.

5. Warranty. The warranty for the Products is as follows:

(i) Goods are warranted against defects in material or workmanship for a period of twelve (12) months from the date of delivery or 2,000 hours of use, whichever occurs first; (ii) Services shall be performed in accordance with generally accepted practices and using the degree of care and skill that is ordinarily exercised and customary in the field to which the Services pertain and are warranted for a period of six (6) months from the date of completion of the Services; and (iii) Software is only warranted to perform in accordance with applicable specifications provided by Seller to Buyer for ninety (90) days from the date of delivery or, when downloaded by a Buyer or end-user, from the date of the initial download. All prices are based upon the exclusive limited warranty stated above, and upon the following disclaimer: EXEMPTION CLAUSE; DISCLAIMER OF WARRANTY, CONDITIONS, REPRESENTATIONS: THIS WARRANTY IS THE SOLE AND ENTIRE WARRANTY, CONDITION, AND REPRESENTATION, PERTAINING TO PRODUCTS. SELLER DISCLAIMS ALL OTHER WARRANTIES, CONDITIONS, AND REPRESENTATIONS, WHETHER STATUTORY, EXPRESS OR IMPLIED, INCLUDING BUT NOT LIMITED TO THOSE RELATING TO DESIGN, NONINFRINGEMENT, MERCHANTABILITY, AND FITNESS FOR A PARTICULAR PURPOSE. SELLER DOES NOT WARRANT THAT THE SOFTWARE IS ERROR-FREE OR FAULT-TOLERANT, OR THAT BUYER'S USE THEREOF WILL BE SECURE OR UNINTERRUPTED, UNLESS OTHERWISE AUTHORIZED IN WRITING BY SELLER, THE SOFTWARE SHALL NOT BE USED IN CONNECTION WITH HAZARDOUS OR HIGH-RISK ACTIVITIES OR ENVIRONMENTS. EXCEPT AS EXPRESSLY STATED HEREIN, ALL PRODUCTS ARE PROVIDED "AS IS".

6. Claims; Commencement of Actions. Buyer shall promptly inspect all Products upon receipt. No claims for shortages will be allowed unless reported to Seller within ten (10) days of delivery. Buyer shall notify Seller of any alleged breach of warranty within thirty (30) days after the date the non-conformance is or should have been discovered by Buyer. Any claim or action against Seller based upon breach of contract or any other theory, including tort, negligence, or otherwise must be commenced within twelve (12) months from the date of the alleged breach or other alleged event, without regard to the date of discovery.

7. LIMITATION OF LIABILITY. IN THE EVENT OF A BREACH OF WARRANTY, SELLER WILL, AT ITS OPTION, REPAIR OR REPLACE THE NON-CONFORMING PRODUCTS, RE-PERFORM THE SERVICES, OR REFUND THE PURCHASE PRICE PAID WITHIN A REASONABLE PERIOD OF TIME. IN NO EVENT IS SELLER LIABLE FOR ANY SPECIAL, INDIRECT, INCIDENTAL OR CONSEQUENTIAL DAMAGES INCLUDING ANY LOSS OF REVENUE OR PROFITS, WHETHER BASED IN CONTRACT, TORT OR OTHER LEGAL THEORY. IN NO EVENT SHALL SELLER'S LIABILITY UNDER ANY CLAIM MADE BY BUYER EXCEED THE PURCHASE PRICE PAID FOR THE PRODUCTS.

8. Confidential Information. Buyer acknowledges and agrees that Confidential Information has been and will be received in confidence and will remain the property of Seller. Buyer further agrees that it will not use Seller's Confidential Information for any purpose other than for the benefit of Seller and shall return all such Confidential Information to Seller within thirty (30) days upon request.

9. Loss to Buyer's Property. Buyer's Property will be considered obsolete and may be destroyed by Seller after two (2) consecutive years have elapsed without Buyer ordering the Products manufactured using Buyer's Property. Also, Seller shall not be responsible for any loss or damage to Buyer's Property while it is in Seller's possession or control.

10. Special Tooling. Seller may impose a tooling charge for any Special Tooling. Special Tooling shall be and remain Seller's property. In no event will Buyer acquire any interest in the Special Tooling, even if such Special Tooling has been specially converted or adapted for manufacture of Goods for Buyer and notwithstanding any charges paid by Buyer. Unless otherwise agreed, Seller has the right to alter, discard or otherwise dispose of any Special Tooling or other property owned by Seller in its sole determination at any time.

11. Security Interest. To secure payment of all sums due from Buyer, Seller retains a security interest in all Products delivered to Buyer and, Buyer's acceptance of these Terms is deemed to be a Security Agreement under the Uniform Commercial Code. Buyer authorizes Seller as its attorney to execute and file on Buyer's behalf all documents Seller deems necessary to perfect Seller's security interest.

12. User Responsibility. Buyer, through its own analysis and testing, is solely responsible for making the final selection of the Products and assuring that all performance, endurance, maintenance, safety and warning requirements of the application of the Products are met. Buyer must analyze all aspects of the application and follow applicable industry standards, specifications, and any technical information provided with the Quote or the Products, such as

Seller's instructions, guides and specifications. If Seller provides options of or for Products based upon data or specifications provided by Buyer, Buyer is responsible for determining that such data and specifications are suitable and sufficient for all applications and reasonably foreseeable uses of the Products. In the event Buyer is not the end-user of the Products, Buyer will ensure such end-user complies with this paragraph.

13. Use of Products, Indemnity by Buyer. Buyer shall comply with all instructions, guides and specifications provided by Seller with the Quote or the Products. If Buyer uses or resells the Products in any way prohibited by Seller's instructions, guides or specifications, or Buyer otherwise fails to comply with Seller's instructions, guides and specifications, Buyer acknowledges that any such use, resale, or non-compliance is at Buyer's sole risk. Further, Buyer shall indemnify, defend, and hold Seller harmless from any losses, claims, liabilities, damages, lawsuits, judgments and costs (including attorney fees and defense costs), whether for personal injury, property damage, intellectual property infringement or any other claim, arising out of or in connection with: (a) improper selection, design, specification, application, or any misuse of Products; (b) any act or omission, negligent or otherwise, of Buyer; (c) Seller's use of Buyer's Property; (d) damage to the Products from an external cause, repair or attempted repair by anyone other than Seller, failure to follow instructions, guides and specifications provided by Seller, use with goods not provided by Seller, or opening, modifying, deconstructing, tampering with or repackaging the Products; or (e) Buyer's failure to comply with these Terms, including any legal or administrative proceedings, collection efforts, or other actions arising from or relating to such failure to comply. Seller shall not indemnify Buyer under any circumstance except as otherwise provided in these Terms.

14. Cancellations and Changes. Buyer may not cancel or modify, including but not limited to movement of delivery dates for the Products, any order for any reason except with Seller's written consent and upon terms that will indemnify, defend and hold Seller harmless against all direct, incidental and consequential loss or damage and any additional expense. Seller, at any time, may change features, specifications, designs and availability of Products.

15. Assignment. Buyer may not assign its rights or obligations without the prior written consent of Seller.

16. Force Majeure. Seller is not liable for delay or failure to perform any of its obligations by reason of any events or circumstances beyond its reasonable control. Such circumstances include without limitation: accidents, labor disputes or stoppages, government acts or orders, acts of nature, pandemics, epidemics, other widespread illness, or public health emergency, cyber related disruptions, cyber-attacks, ransomware sabotage, delays or failures in delivery from carriers or suppliers, shortages of materials, sudden increases in the price of raw material or components, shutdowns or slowdowns affecting the supply of raw materials or components, or the transportation thereof, oil shortages or oil price increases, energy crisis, energy or fuel interruption, war (whether declared or not) or the serious threat of same, riots, rebellions, acts of terrorism, embargoes, fire or any reason whether similar to the foregoing or otherwise. Seller will resume performance as soon as practicable after the event of force majeure has been removed. All delivery dates affected by an event of force majeure shall be tolled for the duration of such event of force majeure and rescheduled for mutually agreed dates as soon as practicable after the event of force majeure ceases to exist. The right to allocate capacity is in the Seller's sole discretion. An event of force majeure shall not include financial distress, insolvency, bankruptcy, or other similar conditions affecting one of the parties, affiliates and/or sub-contractors. An event of force majeure in the meaning of these Terms means any circumstances beyond Seller's control that permanently or temporarily hinders performance, even where that circumstance was already foreseen. Buyer shall not be entitled to cancel any orders following its claim of an event of force majeure.

17. Waiver and Severability. Failure to enforce any provision of these Terms will not invalidate that provision; nor will any such failure prejudice either party's right to enforce that provision in the future. Invalidation of any provision of these Terms shall not invalidate any other provision herein and, the remaining provisions will remain in full force and effect.

18. Duration. Unless otherwise stated in the Quote, any agreement governed by or arising from these Terms shall: (a) be for an initial duration of one (1) year; and (b) shall automatically renew for successive one-year terms unless terminated by Buyer with at least 180-days written notice to Seller or if Seller terminates the agreement pursuant to Section 19 of these Terms.

19. Termination. Seller may, without liability to Buyer, terminate any agreement governed by or arising from these Terms for any reason and at any time by giving Buyer thirty (30) days prior written notice. Seller may immediately terminate, in writing, if Buyer: (a) breaches any provision of these Terms, (b) becomes or is deemed insolvent, (c) appoints or has appointed a trustee, receiver or custodian for all or any part of Buyer's property, (d) files a petition for relief in bankruptcy on its own behalf, or one is filed against Buyer by a third party, (e) makes an assignment for the benefit of creditors; or (f) dissolves its business or liquidates all or a majority of its assets.

20. Ownership of Rights. Buyer agrees that (a) Seller (and/or its affiliates) owns or is the valid licensee of Seller's IP and (b) the furnishing of information, related documents or other materials by Seller to Buyer does not grant or transfer any ownership interest or license in or to Seller's IP to Buyer, unless expressly agreed in writing. Without limiting the foregoing, Seller retains ownership of all

Software supplied to Buyer. In no event shall Buyer obtain any greater right in and to the Software than a right in a license limited to the use thereof and subject to compliance with any other terms provided with the Software. Buyer further agrees that it will not, directly or through intermediaries, reverse engineer, decompile, or disassemble any Software (including firmware) comprising or contained within a Product, except and only to the extent that such activity may be expressly permitted, either by applicable law or, in the case of open source software, the applicable open source license.

21. Indemnity for Infringement of Intellectual Property Rights. Seller is not liable for infringement of any Intellectual Property Rights except as provided in this Section. Seller will defend at its expense and will pay the cost of any settlement or damages awarded in an action brought against Buyer based on a third-party claim that one or more of the Products infringes the Intellectual Property Rights of a third party in the country of delivery of the Products by Seller to Buyer. Seller's obligation to defend and indemnify Buyer is contingent on Buyer notifying Seller within ten (10) days after Buyer becomes aware of any such claim, and Seller having sole control over the defense of the claim including all negotiations for settlement or compromise. If one or more Products is subject to such a claim, Seller may, at its sole expense and option, procure for Buyer the right to continue using the Products, replace or modify the Products to render them non-infringing, or offer to accept return of the Products and refund the purchase price less a reasonable allowance for depreciation. Seller has no obligation or liability for any claim of infringement: (i) arising from information provided by Buyer (including Seller's use of Buyer's Property); or (ii) directed to any Products for which the designs are specified in whole or part by Buyer; or (iii) resulting from the modification, combination or use in a system of any Products. The foregoing provisions of this Section constitute Seller's sole and exclusive liability and Buyer's sole and exclusive remedy for claims of infringement of Intellectual Property Rights.

22. Governing Law. These Terms, the terms of any Quote, and the sale and delivery of all Products are deemed to have taken place in, and shall be governed and construed in accordance with, the laws of the State of Ohio, as applicable to contracts executed and wholly performed therein and without regard to conflicts of laws principles. Buyer irrevocably agrees and consents to the exclusive jurisdiction and venue of the courts of Cuyahoga County, Ohio with respect to any dispute, controversy or claim arising out of or relating to the sale and delivery of the Products.

23. Entire Agreement. These Terms, along with the terms set forth in the Quote, forms the entire agreement between the Buyer and Seller and constitutes the final, complete and exclusive expression of the terms of sale and purchase. In the event of a conflict between any term set forth in the Quote and these Terms, the terms set forth in the Quote shall prevail. All prior or contemporaneous written or oral agreements or negotiations with respect to the subject matter shall have no effect. No modification to these Terms will be binding on Seller unless agreed to in a writing that is signed by an authorized representative of Seller, excluding email correspondence, 'clickwrap' or other purported electronic assent to different or additional terms. Sections 2-25 of these Terms shall survive termination or cancellation of any agreement governed by or arising from these Terms.

24. No 'Wrap' Agreements/No Authority to Bind. Seller's clicking any buttons or any similar action, such as clicking "I Agree" or "Confirm," to utilize Buyer's software or webpage for the placement of orders, is NOT an agreement to Buyer's Terms and Conditions. NO EMPLOYEE, AGENT OR REPRESENTATIVE OF SELLER HAS THE AUTHORITY TO BIND SELLER BY THE ACT OF CLICKING ANY BUTTON OR SIMILAR ACTION ON BUYER'S WEBSITE OR PORTAL.

25. Compliance with Laws. Buyer agrees to comply with all applicable laws, regulations, and industry and professional standards, including those of the United States of America, and the country or countries in which Buyer may operate, including without limitation the U.S. Foreign Corrupt Practices Act ("FCPA"), the U.S. Anti-Kickback Act ("Anti-Kickback Act"), U.S. and E.U. export control and sanctions laws ("Export Laws"), the U.S. Food Drug and Cosmetic Act ("FDCA"), and the rules and regulations promulgated by the U.S. Food and Drug Administration ("FDA"), each as currently amended. Buyer agrees to indemnify, defend, and hold harmless Seller from the consequences of any violation of such laws, regulations and standards by Buyer, its employees or agents. Buyer represents that it is familiar with all applicable provisions of the FCPA, the Anti-Kickback Act, Export Laws, the FDCA and the FDA and certifies that Buyer will adhere to the requirements thereof and not take any action that would make Seller violate such requirements. Buyer represents and agrees that Buyer will not make any payment or give anything of value, directly or indirectly, to any governmental official, foreign political party or official thereof, candidate for foreign political office, or commercial entity or person, for any improper purpose, including the purpose of influencing such person to purchase Products or otherwise benefit the business of Seller. Buyer further represents and agrees that it will not receive, use, service, transfer or ship any Products from Seller in a manner or for a purpose that violates Export Laws or would cause Seller to be in violation of Export Laws. Buyer agrees to promptly and reliably provide Seller all requested information or documents, including end-user statements and other written assurances, concerning Buyer's ongoing compliance with Export Law.

Pioneer has been “The Farmer’s Choice” Since 1949

The Pioneer brand represents quality and value, and has become the product of choice for farmers around the globe. The original Pioneer quick coupling design is still the standard today.



Parker Hannifin Corporation
Pioneer Products Group
8145 Lewis Road
Minneapolis, MN 55427

763-544-7781
fax: 763-544-3418
www.parker.com



Catalog 3900 April 2022