

Air Preparation Products
14 Series Products

14F Particulate Filters	D2-D3
10F Coalescing Filters	D4-D5
14R Regulators	D6-D7
14E Filter / Regulators	D8-D9
04L Lubricators	D10-D11
14A / 14G Combinations	D12-D13

D

**14 Series
Products**



14F Particulate Filters – Miniature

- Excellent water removal efficiency
- Unique deflector plate that creates swirling of the air stream ensuring maximum water and dirt separation
- Easily disassembled for servicing without the use of tools
- 5 micron element standard
- Interchangeable twist and automatic pulse drains
- 1/8" & 1/4" ports (NPT, BSPP & BSPT)

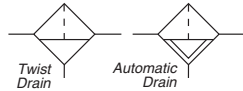

Port size	Description †	Part number
1/8"	Poly bowl, twist drain	14F01BB
1/8"	Metal bowl, twist drain	14F03BB
1/8"	Poly bowl, auto pulse drain	14F05BB
1/8"	Metal bowl, auto pulse drain	14F07BB
1/4"	Poly bowl, twist drain	14F11BB
1/4"	Metal bowl, twist drain	14F13BB
1/4"	Poly bowl, auto pulse drain	14F15BB
1/4"	Metal bowl, auto pulse drain	14F17BB

† For polycarbonate bowl, see caution in Engineering Section A.

Operating information

Supply pressure (max):		
Plastic bowl		0 to 150 psig (0 to 10.3 bar)
Metal bowl		0 to 250 psig (0 to 17.2 bar)
Auto pulse drain		10 to 250 psig (0.7 to 17.2 bar)
Operating temperature:		
Plastic bowl		32°F to 125°F (0°C to 52°C)
Metal bowl		32°F to 175°F (0°C to 80°C)
Auto pulse drain		125°F (52°C) or less
Flow capacity†:		
High flow	1/8"	22 scfm (10.4 dm ³ /s, ANR)
	1/4"	24 scfm (11.3 dm ³ /s, ANR)
Bowl capacity:		1 oz.
Auto pulse drain tube barb		1/8 inch
Weight:		0.41 lb (0.18 kg)

† scfm = Standard cubic feet per minute at 90 psig inlet and 5 psig pressure drop.

Ordering information:

14F 1 1 B B

Port Size	
1/8 inch	0
1/4 inch	1

Port Type	
Blank	NPT
1	BSPP
2	BSPT

Bowl Options	
Poly bowl, twist drain	1
Poly bowl, auto pulse drain	5
Metal bowl, twist drain	3
Metal bowl, auto pulse drain	7

Engineering Level	
B	Current

Element	
A	40 Micron
B	5 Micron
Z	Adsorber

Most popular.



For inventory, lead times, and kit lookup, visit www.pdnplu.com

Miniature Particulate Filters

Material Specifications

Body	Zinc
Transparent bowl	Polycarbonate
Metal bowl without sight gauge	Zinc
Deflector, element holder & baffle	Plastic
Twist drain, body & stem	Plastic
Twist drain, seals	Nitrile
Auto pulse drain, piston & seals	Nitrile
Auto pulse drain, stem, seat, adaptor & washers	Aluminum
Element	Plastic
Adsorber (optional)	Activated charcoal
Seals	Nitrile

Repair and Service Kits

Poly bowl / auto pulse drain	PS408BP
Poly bowl / twist drain	PS404P
Metal bowl / auto pulse drain	PS451BP
Metal bowl / twist drain	PS447BP
40 Micron element	PS401P
5 Micron element	PS403P
5 Micron cartridge kit	PS407P
Adsorber element	PS452P
Mounting bracket kit	PS417BP

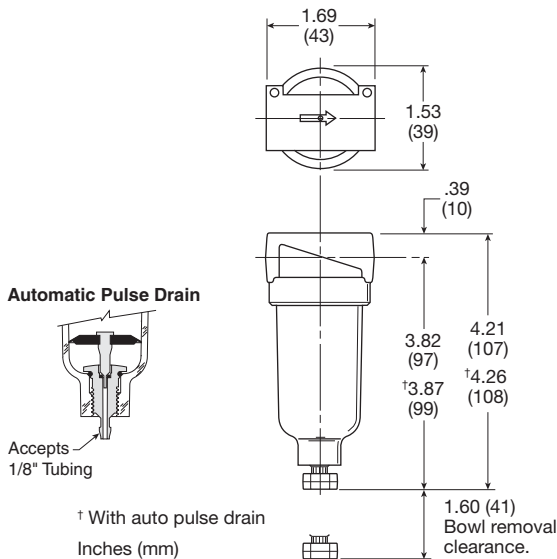

Air Preparation Products

14 Series

Flow Charts

14F 1/8" Particulate Filter

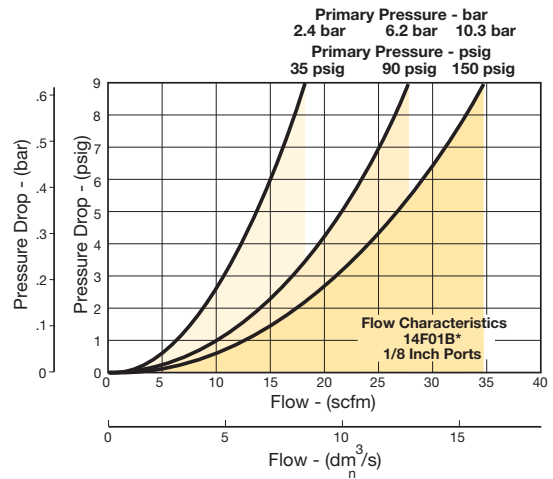

14F 1/4" Particulate Filter

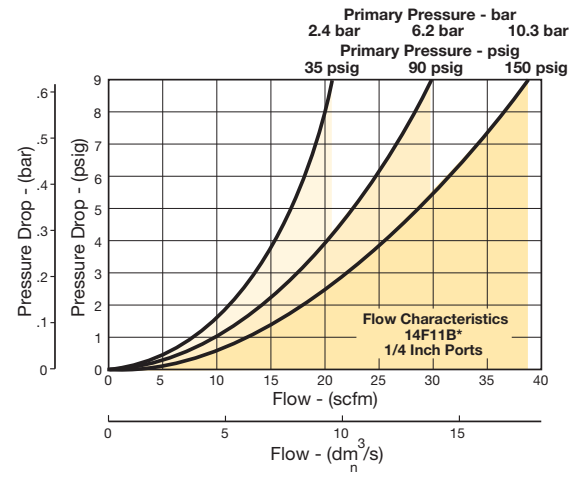

D

14 Series
Products

Filters

Coalescers

Regulators

Filter /
Regulators

Lubricators

Combinations



For inventory, lead time, and kit lookup, visit www.pdnplu.com

10F Coalescing Filters – Miniature

- Removes liquid aerosols and sub-micron particles.
- Liquids gravitate to the bottom of the element and will not re-enter the airstream.
- Oil free air for critical applications, such as air gauging and pneumatic instrumentation and controls.
- Interchangeable twist and automatic pulse drains.
- Grade 6 element, 99.97% DOP efficiency
- 1/8", 1/4" ports (NPT, BSPP, BSPT)

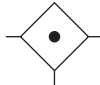

Port size	Description ‡	Part number
1/8"	Poly bowl, twist drain	10F01ED
1/8"	Metal bowl, twist drain	10F03ED
1/8"	Poly bowl, auto pulse drain	10F05ED
1/8"	Metal bowl, auto pulse drain	10F07ED
1/4"	Poly bowl, twist drain	10F11ED
1/4"	Metal bowl, twist drain	10F13ED
1/4"	Poly bowl, auto pulse drain	10F15ED
1/4"	Metal bowl, auto pulse drain	10F17ED

Standard part numbers shown bold, with Grade 6 Elements (for Grade 10 Elements, replace "E" with "H" in the 6th position). For other models refer to ordering information below.

‡ For polycarbonate bowl, see caution in Engineering Section A.

Operating information

Supply pressure (max):		
Plastic bowl		0 to 150 psig (0 to 10.3 bar)
Metal bowl		0 to 250 psig (0 to 17.2 bar)
Auto pulse drain		10 to 250 psig (0.7 to 17.2 bar)
Operating pressure drop:		
Normal		2 psig (0.14 bar)
Max recommended		10 psig (0.7 bar)
(Element should be replaced)		
Operating temperature:		
Plastic bowl		32°F to 125°F (0°C to 52°C)
Metal bowl		32°F to 175°F (0°C to 80°C)
Auto pulse drain		125°F (52°C) or less
Flow capacity†:	Grade 6	1/8" 17 scfm (8 dm ³ /s, ANR)
	(0.01 micron)	1/4" 20 scfm (9.4 dm ³ /s, ANR)
	Grade 10	1/8" 19 scfm (9 dm ³ /s, ANR)
	(1.0 micron)	1/4" 24 scfm (11.3 dm ³ /s, ANR)
Bowl capacity:		1 oz.
Auto pulse drain tube barb		1/8 inch
Weight:		0.41 lb (0.18 kg)
† scfm = Standard cubic feet per minute at 90 psig inlet and 5 psig pressure drop.		

Ordering information:

10F	1	1	E	D	 																					
<table border="1"> <thead> <tr><th>Port Size</th></tr> </thead> <tbody> <tr><td>1/8 inch</td><td>0</td></tr> <tr><td>1/4 inch</td><td>1</td></tr> </tbody> </table>		Port Size	1/8 inch	0	1/4 inch	1	<table border="1"> <thead> <tr><th>Bowl Options</th></tr> </thead> <tbody> <tr><td>Poly bowl, twist drain</td><td>1</td></tr> <tr><td>Poly bowl, auto pulse drain</td><td>5</td></tr> <tr><td>Metal bowl, twist drain</td><td>3</td></tr> <tr><td>Metal bowl, auto pulse drain</td><td>7</td></tr> </tbody> </table>		Bowl Options	Poly bowl, twist drain	1	Poly bowl, auto pulse drain	5	Metal bowl, twist drain	3	Metal bowl, auto pulse drain	7	<table border="1"> <thead> <tr><th>Port Type</th></tr> </thead> <tbody> <tr><td>Blank</td><td>NPT</td></tr> <tr><td>1</td><td>BSPP</td></tr> <tr><td>2</td><td>BSPT</td></tr> </tbody> </table>		Port Type	Blank	NPT	1	BSPP	2	BSPT
Port Size																										
1/8 inch	0																									
1/4 inch	1																									
Bowl Options																										
Poly bowl, twist drain	1																									
Poly bowl, auto pulse drain	5																									
Metal bowl, twist drain	3																									
Metal bowl, auto pulse drain	7																									
Port Type																										
Blank	NPT																									
1	BSPP																									
2	BSPT																									
			<table border="1"> <thead> <tr><th>Engineering Level</th></tr> </thead> <tbody> <tr><td>D</td><td>Current</td></tr> </tbody> </table>			Engineering Level	D	Current																		
Engineering Level																										
D	Current																									
			<table border="1"> <thead> <tr><th>Element</th></tr> </thead> <tbody> <tr><td>E</td><td>Grade 6</td></tr> <tr><td>H</td><td>Grade 10</td></tr> </tbody> </table>			Element	E	Grade 6	H	Grade 10																
Element																										
E	Grade 6																									
H	Grade 10																									

Most popular.



For inventory, lead times, and kit lookup, visit www.pdnplu.com

Miniature Coalescing Filters

Material Specifications

Body	Zinc
Transparent bowl	Polycarbonate
Metal bowl without sight gauge	Zinc
Twist drain, body & stem	Plastic
Twist drain, seals	Nitrile
Auto pulse drain, piston & seals	Nitrile
Auto pulse drain, stem, seat, adaptor & washers	Aluminum
Element holder	Plastic
Element	Borosilicate & felt glass fibers
Seals	Nitrile

Repair and Service Kits

Poly bowl / auto pulse drain kit	PS408BP
Poly bowl / twist drain kit	PS404P
Metal bowl / auto pulse drain kit	PS451BP
Metal bowl / twist drain kit	PS447BP
Grade 6 element (standard)	PS446P
Grade 10 element (optional)	PS456P
Mounting bracket kit	PS417BP

Automatic Pulse Drain

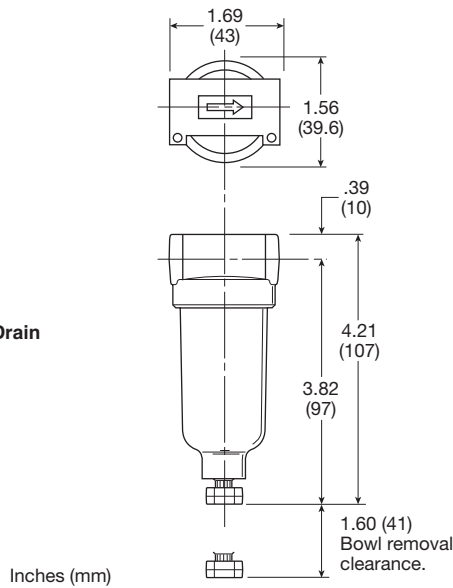
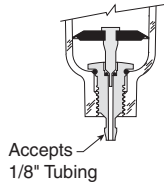

Air Preparation Products 14 Series

Flow Charts

Grade 6 Element

10F 1/8" Coalescing Filter

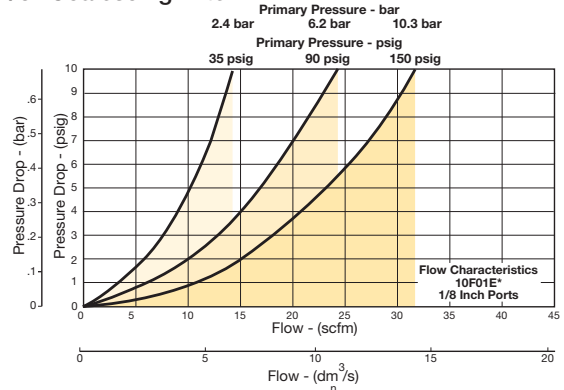

10F 1/4" Coalescing Filter

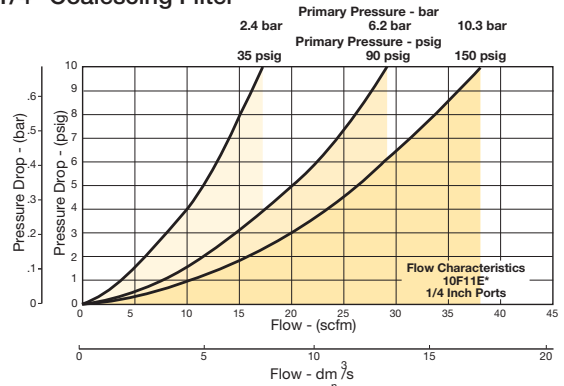

Grade 10 Element

10F 1/8" Coalescing Filter

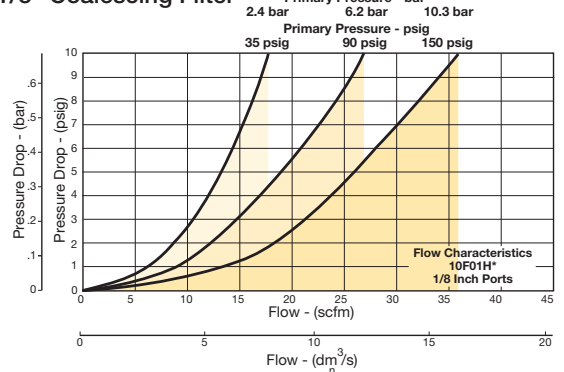

10F 1/4" Coalescing Filter

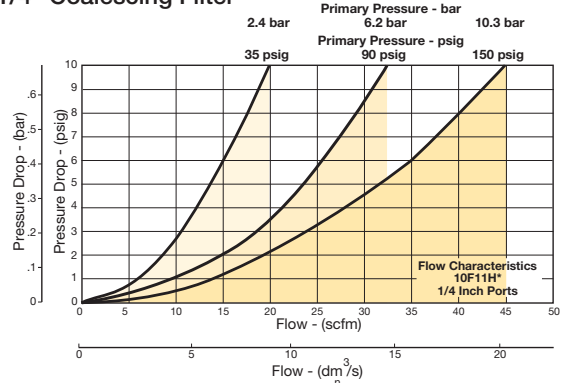

D

14 Series
Products

Filters

Coalescers

Regulators

Filter /
Regulators

Lubricators

Combinations



For inventory, lead time, and kit lookup, visit www.pdnplu.com

Miniature Regulators

14R Regulators – Miniature

- Unbalanced poppet standard
- Solid control piston with lip seal for extended life
- Non-rising adjusting knob
- Compact design
- Very easy to service
- 1/8", 1/4" ports (NPT, BSPP, BSPT)

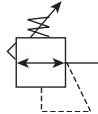

Port size	Description	Part number
1/8"	Without gauge	14R013FC
1/8"	With gauge	14R018FC
1/4"	Without gauge	14R113FC
1/4"	With gauge	14R118FC

NOTE: 1.218 Dia. (31 mm) hole required for panel mounting.

Operating information

Supply pressure (max):	0 to 300 psig (0 to 20.7 bar)
Secondary pressure ranges	
Standard	2 to 125 psig (0 to 8.6 bar)
Medium	1 to 60 psig (0 to 4.1 bar)
Medium	1 to 30 psig (0 to 2.1 bar)
Low	1 to 15 psig (0 to 1 bar)
Operating temperature:	32°F to 125°F (0°C to 52°C)
Low temperature	-4°F to 125°F (-20°C to 52°C)
Flow capacity†:	
High flow	1/8" 13 scfm (6.1 dm ³ /s, ANR)
1/4"	15 scfm (7.1 dm ³ /s, ANR)
Gauge ports (2):	1/8 or 1/4 inch
Weight:	0.3 lb (0.14 kg)

† scfm = Standard cubic feet per minute at 100 psig inlet, 90 psig no flow secondary setting and 10 psig pressure drop.

Ordering information:

14R
1
13
F
C

<table border="1" style="width: 100%; border-collapse: collapse;"> <thead> <tr> <th colspan="2">Port Size</th> </tr> </thead> <tbody> <tr> <td>1/8 inch pipe, 1/8 inch gauge port</td> <td>0</td> </tr> <tr> <td>1/4 inch pipe, 1/8 inch gauge port</td> <td>1</td> </tr> <tr> <td>1/4 inch pipe, 1/4 inch gauge port</td> <td>B</td> </tr> <tr> <td>1/8 inch pipe, no gauge port</td> <td>C</td> </tr> <tr> <td>Manifold mounting</td> <td>M</td> </tr> </tbody> </table>	Port Size		1/8 inch pipe, 1/8 inch gauge port	0	1/4 inch pipe, 1/8 inch gauge port	1	1/4 inch pipe, 1/4 inch gauge port	B	1/8 inch pipe, no gauge port	C	Manifold mounting	M	<table border="1" style="width: 100%; border-collapse: collapse;"> <thead> <tr> <th colspan="2">Port Type</th> </tr> </thead> <tbody> <tr> <td>Blank</td> <td>NPT</td> </tr> <tr> <td>1</td> <td>BSPP</td> </tr> <tr> <td>2</td> <td>BSPT</td> </tr> </tbody> </table>	Port Type		Blank	NPT	1	BSPP	2	BSPT	<table border="1" style="width: 100%; border-collapse: collapse;"> <thead> <tr> <th colspan="2">Preset / Pressure Limited</th> </tr> </thead> <tbody> <tr> <td>Blank</td> <td>None</td> </tr> <tr> <td>XXX*</td> <td>Preset pressure</td> </tr> <tr> <td>XXX*</td> <td>Pressure limited</td> </tr> </tbody> </table> <p style="font-size: small;">* Available preset / pressure limited range, 10 to 90 psig in 5 psig increments. For higher pressures, contact factory. (Example: 065 = 65 psig)</p>	Preset / Pressure Limited		Blank	None	XXX*	Preset pressure	XXX*	Pressure limited	<table border="1" style="width: 100%; border-collapse: collapse;"> <thead> <tr> <th colspan="2">Engineering Level</th> </tr> </thead> <tbody> <tr> <td>C</td> <td>Current</td> </tr> </tbody> </table>	Engineering Level		C	Current																																					
Port Size																																																																								
1/8 inch pipe, 1/8 inch gauge port	0																																																																							
1/4 inch pipe, 1/8 inch gauge port	1																																																																							
1/4 inch pipe, 1/4 inch gauge port	B																																																																							
1/8 inch pipe, no gauge port	C																																																																							
Manifold mounting	M																																																																							
Port Type																																																																								
Blank	NPT																																																																							
1	BSPP																																																																							
2	BSPT																																																																							
Preset / Pressure Limited																																																																								
Blank	None																																																																							
XXX*	Preset pressure																																																																							
XXX*	Pressure limited																																																																							
Engineering Level																																																																								
C	Current																																																																							
<table border="1" style="width: 100%; border-collapse: collapse;"> <thead> <tr> <th colspan="4">Pressure Range</th> </tr> <tr> <th colspan="2">Yellow Knob</th> <th colspan="2">Black Knob</th> </tr> </thead> <tbody> <tr> <td colspan="4" style="text-align: center;">Without gauge</td> </tr> <tr> <td>30 psig</td> <td>10</td> <td>30 psig</td> <td>B0</td> </tr> <tr> <td>60 psig</td> <td>11</td> <td>60 psig</td> <td>B1</td> </tr> <tr> <td>15 psig</td> <td>12</td> <td>15 psig</td> <td>B2</td> </tr> <tr> <td>125 psig</td> <td>13</td> <td>125 psig</td> <td>B3</td> </tr> <tr> <td colspan="4" style="text-align: center;">With gauge*</td> </tr> <tr> <td>30 psig</td> <td>15</td> <td>30 psig</td> <td>B5</td> </tr> <tr> <td>60 psig</td> <td>16</td> <td>60 psig</td> <td>B6</td> </tr> <tr> <td>15 psig</td> <td>17</td> <td>15 psig</td> <td>B7</td> </tr> <tr> <td>125 psig</td> <td>18</td> <td>125 psig</td> <td>B8</td> </tr> </tbody> </table> <p style="font-size: x-small;">* Not available with BSPP or BSPT port types.</p>	Pressure Range				Yellow Knob		Black Knob		Without gauge				30 psig	10	30 psig	B0	60 psig	11	60 psig	B1	15 psig	12	15 psig	B2	125 psig	13	125 psig	B3	With gauge*				30 psig	15	30 psig	B5	60 psig	16	60 psig	B6	15 psig	17	15 psig	B7	125 psig	18	125 psig	B8	<table border="1" style="width: 100%; border-collapse: collapse;"> <thead> <tr> <th colspan="2">Relief</th> </tr> </thead> <tbody> <tr> <td>F</td> <td>Relieving</td> </tr> <tr> <td>G</td> <td>Non-relieving</td> </tr> <tr> <td>H</td> <td>Low temp. relieving</td> </tr> <tr> <td>J</td> <td>Low temp. non-relieving</td> </tr> </tbody> </table>	Relief		F	Relieving	G	Non-relieving	H	Low temp. relieving	J	Low temp. non-relieving	<table border="1" style="width: 100%; border-collapse: collapse;"> <thead> <tr> <th colspan="2">Options</th> </tr> </thead> <tbody> <tr> <td>Blank</td> <td>No options</td> </tr> <tr> <td>L †</td> <td>Preset non-adjustable</td> </tr> <tr> <td>p †</td> <td>Preset adjustable</td> </tr> <tr> <td>S †</td> <td>Pressure limiter max. adjustable</td> </tr> <tr> <td>T †</td> <td>Pressure limiter max. non-adjustable</td> </tr> </tbody> </table> <p style="font-size: x-small;">† Inlet pressure is 100 psig. For other pressures contact factory.</p>	Options		Blank	No options	L †	Preset non-adjustable	p †	Preset adjustable	S †	Pressure limiter max. adjustable	T †	Pressure limiter max. non-adjustable
Pressure Range																																																																								
Yellow Knob		Black Knob																																																																						
Without gauge																																																																								
30 psig	10	30 psig	B0																																																																					
60 psig	11	60 psig	B1																																																																					
15 psig	12	15 psig	B2																																																																					
125 psig	13	125 psig	B3																																																																					
With gauge*																																																																								
30 psig	15	30 psig	B5																																																																					
60 psig	16	60 psig	B6																																																																					
15 psig	17	15 psig	B7																																																																					
125 psig	18	125 psig	B8																																																																					
Relief																																																																								
F	Relieving																																																																							
G	Non-relieving																																																																							
H	Low temp. relieving																																																																							
J	Low temp. non-relieving																																																																							
Options																																																																								
Blank	No options																																																																							
L †	Preset non-adjustable																																																																							
p †	Preset adjustable																																																																							
S †	Pressure limiter max. adjustable																																																																							
T †	Pressure limiter max. non-adjustable																																																																							

Spring Type by Preset / Limited Pressure:
 For Preset / Limited Pressure 10 to 25 use 30 psi spring
 For Preset / Limited Pressure 26 to 50 use 60 psi spring
 For Preset / Limited Pressure 51 to 90 use 125 psi spring

Most popular.



For inventory, lead times, and kit lookup, visit www.pdnplu.com

Miniature Regulators

14 Series

Material Specifications

Adjusting nut	Brass
Adjusting stem & spring	Steel
Body	Zinc
Bonnet, seat, piston & valve poppet	Plastic
Seals	Nitrile

Repair and Service Kits

Bonnet assembly kit	L01369
Bonnet tamperproof kit	P01265
30 psig gauge, 1/8" NPT (0 to 2.1 bar)	K4515N18030
60 psig gauge, 1/8" NPT (0 to 4.1 bar)	K4515N18060
160 psig gauge, 1/8" NPT (0 to 11.0 bar)	K4515N18160
60 psig gauge, 1/4" NPT (0 to 4.1 bar)	K4520N14060
160 psig gauge, 1/4" NPT (0 to 11.0 bar)	K4520N14160
Mounting bracket kit* (includes panel mount nut)	PS417BP
Plastic panel mount nuts*	P78652
Metal panel mount nuts*	P01531
Unbalanced non-relieving, poppet / piston kit	PS428P
Unbalanced relieving, poppet / piston kit	PS426P
1-15 psig spring (yellow)	P01176
1-30 psig spring (black)	P01175
1-60 psig spring (white)	P01174
2-125 psig spring (gold)	P01173

* Tighten panel mount nut 2.8 to 3.4 Nm (25 to 30 in-lbs) of torque.

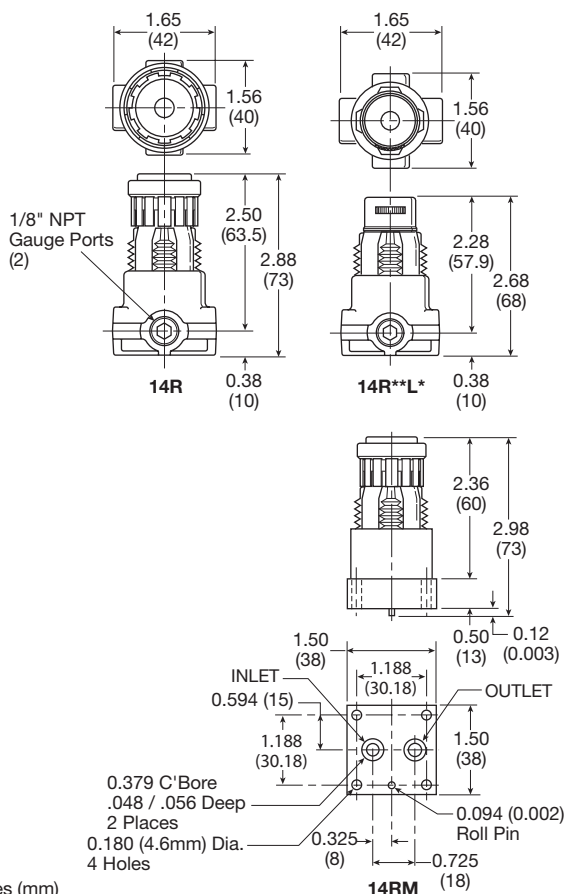

Inches (mm)

Flow Charts

14R 1/8" Ports

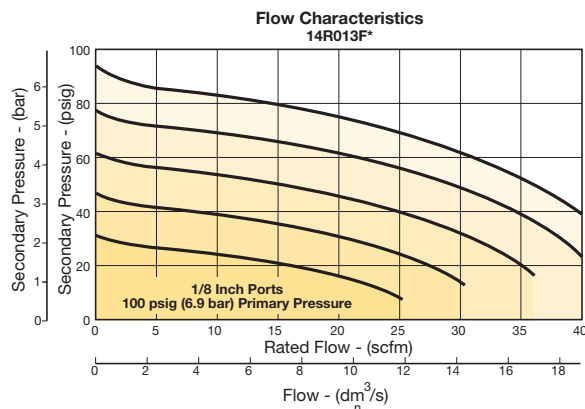

14R 1/4" Ports

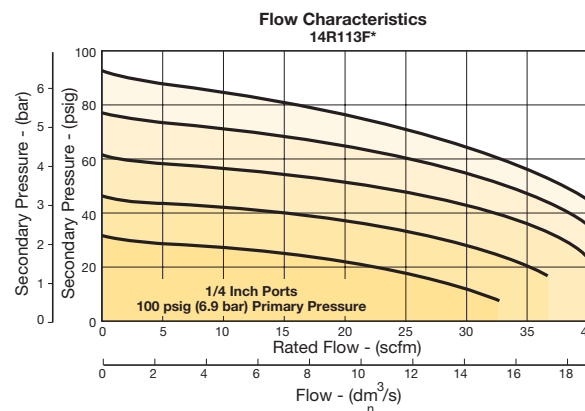

WARNING

Product rupture can cause serious injury.
Do not connect regulator to bottled gas.
Do not exceed Maximum primary pressure rating.

CAUTION:

REGULATOR PRESSURE ADJUSTMENT – The working range of knob adjustment is designed to permit outlet pressures within their full range. Pressure adjustment beyond this range is also possible because the knob is not a limiting device. This is a common characteristic of most industrial regulators, and limiting devices may be obtained only by special design. For best performance, regulated pressure should always be set by increasing the pressure up to the desired setting.



For inventory, lead time, and kit lookup, visit www.pdnplu.com

D
14 Series Products
Filters
Coalescers
Regulators
Filter / Regulators
Lubricators
Combinations

14E Filter / Regulator – Miniature

- Excellent water removal efficiency
- Unbalanced poppet standard
- Solid control piston for extended life
- Space saving package offers both filter and regulator features in one integral unit
- Non-rising adjustment knob
- Two full flow 1/8" gauge ports
- 1/8", 1/4" ports (NPT, BSPP, BSPT)

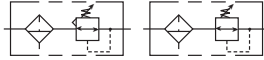

Port size	Description †	Part number
1/8"	Poly bowl, twist drain	14E01B13FC
1/8"	Metal bowl, twist drain	14E03B13FC
1/8"	Poly bowl, auto pulse drain	14E05B13FC
1/8"	Metal bowl, auto pulse drain	14E07B13FC
1/4"	Poly bowl, twist drain	14E11B13FC
1/4"	Metal bowl, twist drain	14E13B13FC
1/4"	Poly bowl, auto pulse drain	14E15B13FC
1/4"	Metal bowl, auto pulse drain	14E17B13FC

† For polycarbonate bowl, see caution in Engineering Section A.
NOTE: 1.218 Dia. (31 mm) hole required for panel mounting.

Operating information

Supply pressure (max):		
Plastic bowl		0 to 150 psig (0 to 10.3 bar)
Metal bowl		0 to 250 psig (0 to 17.2 bar)
Secondary pressure ranges		
Standard		2 to 125 psig (0 to 8.6 bar)
Medium		1 to 30 psig (0 to 2.1 bar)
Medium		1 to 60 psig (0 to 4.1 bar)
Low		1 to 15 psig (0 to 1 bar)
Operating temperature:		
Plastic bowl		32°F to 125°F (0°C to 52°C)
Metal bowl		32°F to 175°F (0°C to 80°C)
Flow capacity†:		
High flow	1/8"	16 scfm (7.6 dm³/s, ANR)
	1/4"	18 scfm (8.5 dm³/s, ANR)
Bowl capacity:		1 oz.
Auto pulse drain tube barb		1/8 inch
Gauge ports (2):		1/8 inch (can be used as additional full flow)
Weight:		0.4 lb (0.18 kg)

† scfm = Standard cubic feet per minute at 100 psig inlet and 10 psig pressure drop.

Ordering information:

14E

Port Size	
1/8 inch	0
1/4 inch	1

1

Bowl Options	
Poly bowl, twist drain	1
Poly bowl, auto pulse drain	5
Metal bowl, twist drain	3
Metal bowl, auto pulse drain	7

1

Element	
40 Micron	A
5 Micron	B
Adsorber	Z

B

13

Pressure Range	Without gauge	With gauge*
30 psig	10	30 psig 15
60 psig	11	60 psig 16
15 psig	12	15 psig 17
125 psig	13	125 psig 18

F

Relief	
F	Relieving
G	Non-relieving
H*	Low temp. relieving

* Twist drain only.

C

Engineering Level	
C	Current

Port Type

Blank	NPT
1	BSPP
2	BSPT

Preset / Pressure Limited

Blank	None
XXX*	Preset pressure
XXX*	Pressure limited

* Available preset / pressure limited range, 10 to 90 psig in 5 psig increments. For higher pressures, contact factory.
(Example: 065 = 65 psig)

Spring Type by Preset / Limited Pressure:

- For Preset / Limited Pressure 10 to 25 use 30 psi spring
- For Preset / Limited Pressure 26 to 50 use 60 psi spring
- For Preset / Limited Pressure 51 to 90 use 125 psi spring

* Not available with BSPP or BSPT port types.

† Inlet pressure is 100 psig. For other pressures contact factory.

Most popular.



For inventory, lead times, and kit lookup, visit www.pdnplu.com

Miniature Filter / Regulators

Material Specifications

Adjusting nut	Brass
Adjusting stem & spring	Steel
Body	Zinc
Bonnet, knob, seat, piston, holder & deflector	Plastic
Transparent bowl	Polycarbonate
Metal bowl (without sight gauge)	Zinc
Twist drain, body & stem	Plastic
Twist drain, seals	Nitrile
Auto pulse drain, piston & seals	Nitrile
Auto pulse drain, stem, seat, adaptor & washers	Aluminum
5 Micron elements (standard)	Plastic
40 Micron elements (optional)	Plastic
Adsorber elements (optional)	Activated charcoal
Seals	Nitrile

Repair and Service Kits

Bonnet tamperproof kit	P01265
Poly bowl / auto drain	PS408BP
Poly bowl / twist drain	PS404P
Metal bowl / auto drain	PS451BP
Metal bowl / twist drain	PS447BP
40 micron element	PS401P
5 micron element	PS403P
Adsorber element	PS452P
30 psig (0 to 2.1 bar), gauge	K4515N18030
60 psig (0 to 4.1 bar), gauge	K4515N18060
160 psig (0 to 11.0 bar), gauge	K4515N18160
Mounting bracket kit* (includes panel mount nut)	PS417BP
Panel mount nut*	P78652
Unbalanced, non-relieving	PS428P
Unbalanced, relieving	PS426P
1- 15 psig spring (yellow)	P01176
1- 30 psig spring (black)	P01175
1- 60 psig spring (white)	P01174
2- 125 psig spring (gold)	P01173

*Tighten panel mount nut 2.8 to 3.4 Nm (25 to 30 in-lbs) of torque.

WARNING

Product rupture can cause serious injury. Do not connect regulator to bottled gas. Do not exceed Maximum primary pressure rating.

CAUTION:

REGULATOR PRESSURE ADJUSTMENT – The working range of knob adjustment is designed to permit outlet pressures within their full range. Pressure adjustment beyond this range is also possible because the knob is not a limiting device. This is a common characteristic of most industrial regulators, and limiting devices may be obtained only by special design. For best performance, regulated pressure should always be set by increasing the pressure up to the desired setting.

Air Preparation Products 14 Series

Flow Charts

14E 1/8" Filter / Regulator

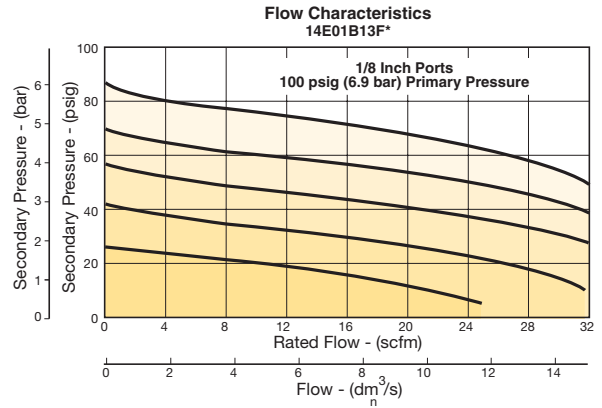

14E 1/4" Filter / Regulator

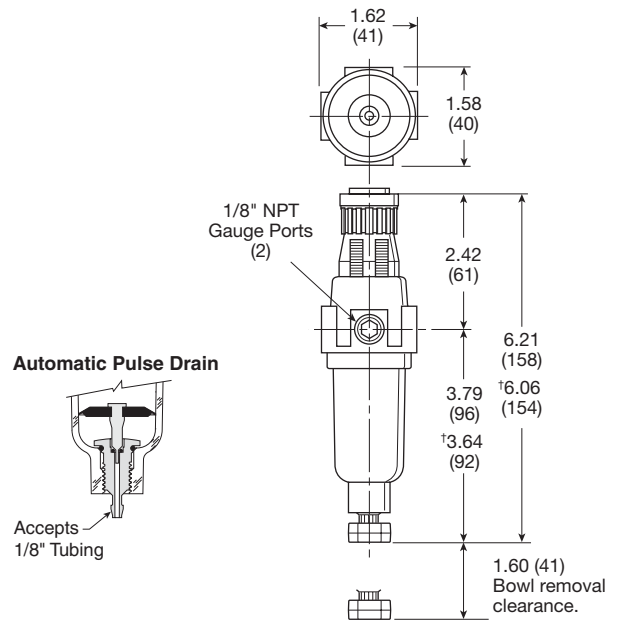
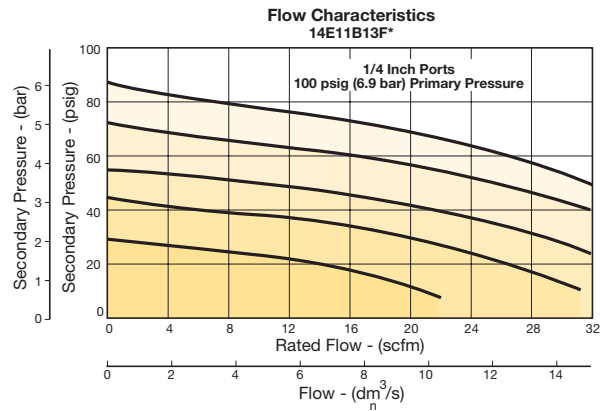

† With auto drain
Inches (mm)



For inventory, lead time, and kit lookup, visit www.pdnplu.com

04L Mist Lubricators – Miniature

- Proportional oil delivery over a wide range of air flows
- Precision needle valve assures repeatable oil delivery and provides simple adjustment of delivery rate
- Ideal for low and high flow applications with changing air flow
- Transparent sight dome for 360° visibility
- Integral 1/8", 1/4" ports (NPT, BSPP, BSPT)



Port size	Description ‡	Part number
1/8"	Poly bowl, no drain	04L00GB
1/8"	Metal bowl, no sight gauge, twist drain	04L03GB
1/4"	Poly bowl, no drain	04L10GB
1/4"	Metal bowl, no sight gauge, twist drain	04L13GB

‡ For polycarbonate bowl and sight dome, see caution in Engineering Section A.

Operating information

Supply pressure (max):		
Plastic bowl		0 to 150 psig (0 to 10.3 bar)
Metal bowl		0 to 250 psig (0 to 17.2 bar)
Operating temperature:		
Plastic bowl		32°F to 125°F (0°C to 52°C)
Metal bowl		32°F to 175°F (0°C to 80°C)
Flow capacity†:		
High flow	1/8"	20 scfm (9.4 dm ³ /s, ANR)
	1/4"	20 scfm (9.4 dm ³ /s, ANR)
Minimum flow		0.5 scfm (0.24 dm ³ /s, ANR) at 100 psig (6.9 bar)
Bowl capacity:		1 oz.
Weight:		0.4 lb (0.18 kg)

† scfm = Standard cubic feet per minute at 90 psig inlet and 5 psig pressure drop.

Ordering information:

04L	1	0	G	B	 												
<table border="1"> <thead> <tr><th>Port Size</th></tr> </thead> <tbody> <tr><td>1/8 inch</td></tr> <tr><td>1/4 inch</td></tr> </tbody> </table>		Port Size	1/8 inch	1/4 inch	<table border="1"> <tbody> <tr><td>0</td></tr> <tr><td>1</td></tr> </tbody> </table>	0	1	<table border="1"> <thead> <tr><th>Port Type</th></tr> </thead> <tbody> <tr><td>Blank</td></tr> <tr><td>1</td></tr> <tr><td>2</td></tr> </tbody> </table>		Port Type	Blank	1	2	<table border="1"> <thead> <tr><th>Engineering Level</th></tr> </thead> <tbody> <tr><td>B</td></tr> <tr><td>Current</td></tr> </tbody> </table>	Engineering Level	B	Current
Port Size																	
1/8 inch																	
1/4 inch																	
0																	
1																	
Port Type																	
Blank																	
1																	
2																	
Engineering Level																	
B																	
Current																	
<table border="1"> <thead> <tr><th>Bowl Options</th></tr> </thead> <tbody> <tr><td>Poly bowl, no drain</td></tr> <tr><td>Poly bowl, twist drain</td></tr> <tr><td>Metal bowl, no sight gauge, twist drain</td></tr> </tbody> </table>		Bowl Options	Poly bowl, no drain	Poly bowl, twist drain	Metal bowl, no sight gauge, twist drain	<table border="1"> <tbody> <tr><td>0</td></tr> <tr><td>1</td></tr> <tr><td>3</td></tr> </tbody> </table>	0	1	3	<table border="1"> <thead> <tr><th>Body</th></tr> </thead> <tbody> <tr><td>G</td></tr> <tr><td>No fill plug</td></tr> </tbody> </table>		Body	G	No fill plug			
Bowl Options																	
Poly bowl, no drain																	
Poly bowl, twist drain																	
Metal bowl, no sight gauge, twist drain																	
0																	
1																	
3																	
Body																	
G																	
No fill plug																	

Suggested Lubricant **F442 Oil**
 Petroleum based oil of 100 to 200 SUS viscosity at 100°F (38°C) and an aniline point greater than 200°F (93°C)
 (DO NOT USE OILS WITH ADDITIVES, COMPOUNDED OILS CONTAINING SOLVENTS, GRAPHITE, DETERGENTS, OR SYNTHETIC OILS.)

 Most popular.



For inventory, lead times, and kit lookup, visit www.pdnplu.com

D
 14 Series Products
 Filters
 Coalescers
 Regulators
 Filter / Regulators
 Lubricators
 Combinations

Miniature Mist Lubricators

Material Specifications

Body	Zinc
Transparent bowls	Polycarbonate
Metal bowl (without sight gauge)	Zinc
Drains, twist – body & nut	Plastic
Seals	Nitrile
Sight dome	Polycarbonate

Repair and Service Kits

Poly bowl / no drain kit	PS421P
Poly bowl / twist drain kit	PS420P
Metal bowl / twist drain (no sight gauge) kit	PS447BP
Mounting bracket kit	PS419
Oil (1 quart)	F442001
Oil (1 gallon)	F442002
Oil (12 quart case)	F442003
Oil (4 gallon case)	F442005

Air Preparation Products 14 Series

Flow Charts

04L 1/8" Lubricator

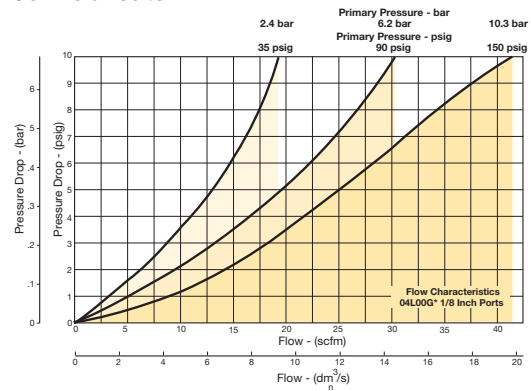

04L 1/4" Lubricator

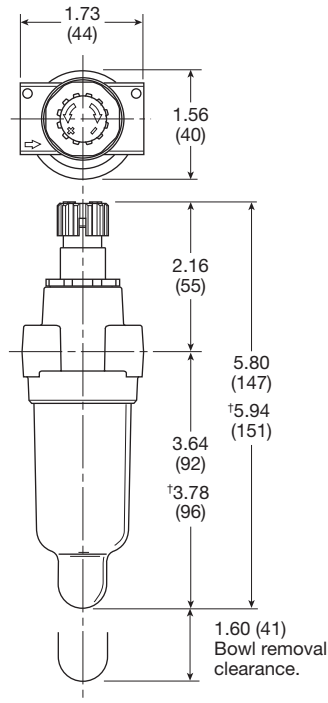
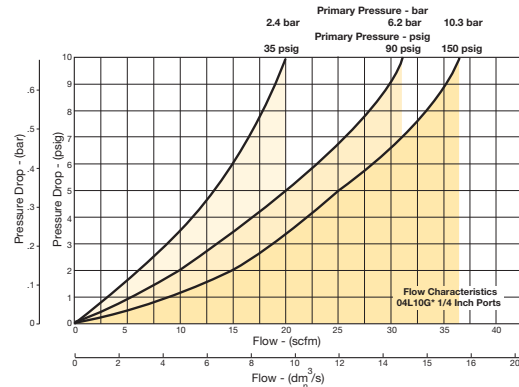

Inches (mm)

D
14 Series
Products

Filters

Coalescers

Regulators

Filter /
Regulators

Lubricators

Combinations



For inventory, lead time, and kit lookup, visit www.pdnplu.com

Close Nipped Combinations

14A / 14G Close Nipped Combinations – Miniature

Close Nipped Combinations – 14 Miniature Series

- Regulator can be mounted with knob in up or down position
- 5 micron filter element standard, 40 micron optional
- Manual twist drain
- Relieving regulator

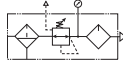

Close Nipped Combinations

	Port size	Bowl type ‡	Element type	Filter drain type	Relief type	Lubricator drain type	Part number (NPT)
14G	1/8"	Poly	5 micron	Twist	Relieving	None	14G01B13F0GD
	1/4"	Poly	5 micron	Twist	Relieving	None	14G11B13F0GD
14A	1/8"	Poly	5 micron	Twist	Relieving	None	14A01B13F0GF
	1/4"	Poly	5 micron	Twist	Relieving	None	14A11B13F0GF

‡ For polycarbonate bowl, see caution in Engineering Section A.

Ordering information:

14A 1 1 B 13 F 0 G *

Series	Engineering Level
3-Unit 14A	D 14G current
2-Unit 14G	F 14A current

Port Size	Lubricator Body Options
1/8 inch 0	G No fill plug
1/4 inch 1	

Filter Bowl Options	Lubricator Bowl Options
Poly bowl, twist drain 1	0 Poly bowl, no drain
Poly bowl, auto pulse drain 5	1 Poly bowl, twist drain
Metal bowl, twist drain 3	3 Metal bowl, twist drain
Metal bowl, auto pulse drain 7	

Filter Element	Relief
40 Micron A	F Relieving
5 Micron B	G Non-relieving

Pressure Range			
Without gauge		With gauge	
10	30 psig	15	30 psig
11	60 psig	16	60 psig
12	15 psig	17	15 psig
13	125 psig	18	125 psig

Most popular.



For inventory, lead times, and kit lookup, visit www.pdnplu.com

Close Nipped Combinations

14G (Close nipped 2-unit)

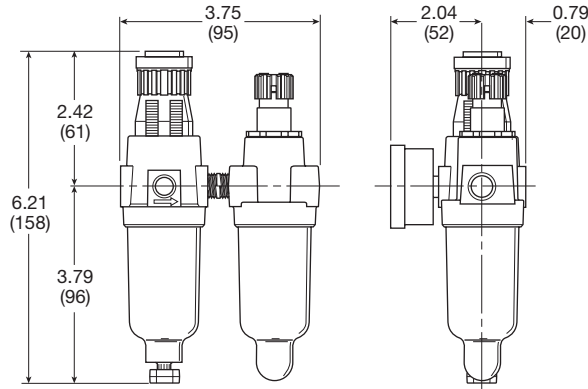

Inches (mm)

14A (Close nipped 3-unit)

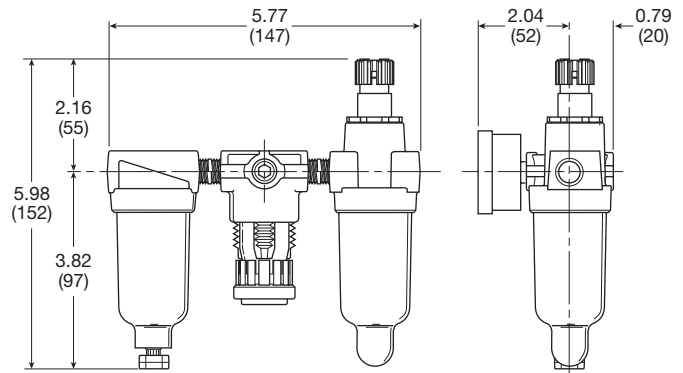

⚠ WARNING

**Product rupture can cause serious injury.
Do not connect regulator to bottled gas.
Do not exceed Maximum primary pressure rating.**

Service kits

Mounting bracket, 14E, 14F, 14R	PS417BP
Mounting bracket, 04L	PS419

CAUTION:

REGULATOR PRESSURE ADJUSTMENT – The working range of knob adjustment is designed to permit outlet pressures within their full range. Pressure adjustment beyond this range is also possible because the knob is not a limiting device. This is a common characteristic of most industrial regulators, and limiting devices may be obtained only by special design. For best performance, regulated pressure should always be set by increasing the pressure up to the desired setting.

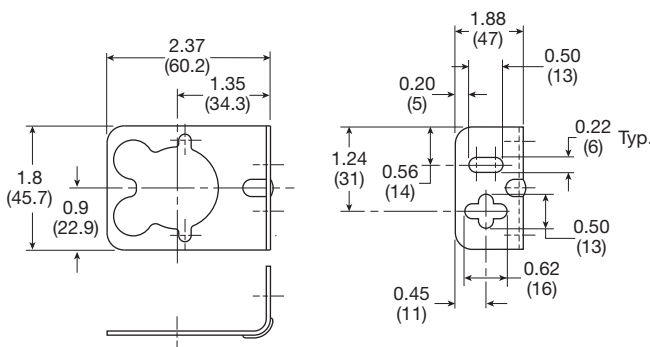

Inches (mm)

PS417BP - 10F, 14F, 14R, 14E
(Includes panel mount nut)

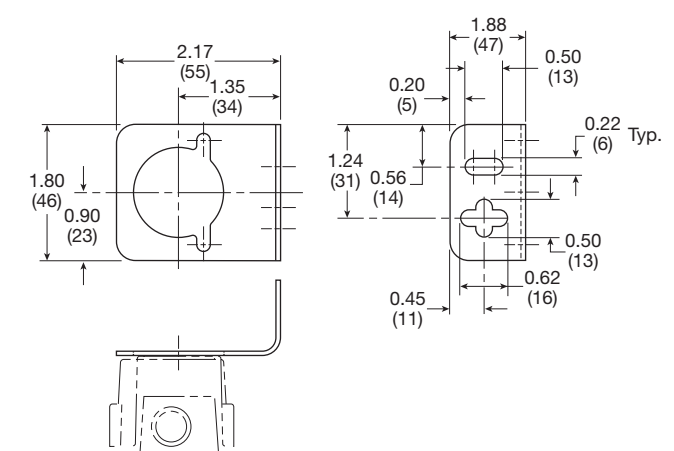

Inches (mm)

PS419 - 04L

D

14 Series
Products

Filters

Coalescers

Regulators

Filter /
Regulators

Lubricators

Combinations



For inventory, lead time, and kit lookup, visit www.pdnplu.com

Safety Guide For Selecting And Using Pneumatic Division Products And Related Accessories

WARNING:

FAILURE OR IMPROPER SELECTION OR IMPROPER USE OF PNEUMATIC DIVISION PRODUCTS, ASSEMBLIES OR RELATED ITEMS ("PRODUCTS") CAN CAUSE DEATH, PERSONAL INJURY, AND PROPERTY DAMAGE. POSSIBLE CONSEQUENCES OF FAILURE OR IMPROPER SELECTION OR IMPROPER USE OF THESE PRODUCTS INCLUDE BUT ARE NOT LIMITED TO:

- Unintended or mistimed cycling or motion of machine members or failure to cycle
- Work pieces or component parts being thrown off at high speeds.
- Failure of a device to function properly for example, failure to clamp or unclamp an associated item or device.
- Explosion
- Suddenly moving or falling objects.
- Release of toxic or otherwise injurious liquids or gasses.

Before selecting or using any of these Products, it is important that you read and follow the instructions below.

1. GENERAL INSTRUCTIONS

- 1.1. Scope:** This safety guide is designed to cover general guidelines on the installation, use, and maintenance of Pneumatic Division Valves, FRLs (Filters, Pressure Regulators, and Lubricators), Vacuum products and related accessory components.
- 1.2. Fail-Safe:** Valves, FRLs, Vacuum products and their related components can and do fail without warning for many reasons. Design all systems and equipment in a fail-safe mode, so that failure of associated valves, FRLs or Vacuum products will not endanger persons or property.
- 1.3 Relevant International Standards:** For a good guide to the application of a broad spectrum of pneumatic fluid power devices see: ISO 4414:1998, Pneumatic Fluid Power – General Rules Relating to Systems. See www.iso.org for ordering information.
- 1.4. Distribution:** Provide a copy of this safety guide to each person that is responsible for selection, installation, or use of Valves, FRLs or Vacuum products. Do not select, or use Parker valves, FRLs or vacuum products without thoroughly reading and understanding this safety guide as well as the specific Parker publications for the products considered or selected.
- 1.5. User Responsibility:** Due to the wide variety of operating conditions and applications for valves, FRLs, and vacuum products Parker and its distributors do not represent or warrant that any particular valve, FRL or vacuum product is suitable for any specific end use system. This safety guide does not analyze all technical parameters that must be considered in selecting a product. The user, through its own analysis and testing, is solely responsible for:
 - Making the final selection of the appropriate valve, FRL, Vacuum component, or accessory.
 - Assuring that all user's performance, endurance, maintenance, safety, and warning requirements are met and that the application presents no health or safety hazards.
 - Complying with all existing warning labels and / or providing all appropriate health and safety warnings on the equipment on which the valves, FRLs or Vacuum products are used; and,
 - Assuring compliance with all applicable government and industry standards.
- 1.6. Safety Devices:** Safety devices should not be removed, or defeated.
- 1.7. Warning Labels:** Warning labels should not be removed, painted over or otherwise obscured.
- 1.8. Additional Questions:** Call the appropriate Parker technical service department if you have any questions or require any additional information. See the Parker publication for the product being considered or used, or call 1-800-CPARKER, or go to www.parker.com, for telephone numbers of the appropriate technical service department.

2. PRODUCT SELECTION INSTRUCTIONS

- 2.1. Flow Rate:** The flow rate requirements of a system are frequently the primary consideration when designing any pneumatic system. System components need to be able to provide adequate flow and pressure for the desired application.
- 2.2. Pressure Rating:** Never exceed the rated pressure of a product. Consult product labeling, Pneumatic Division catalogs or the instruction sheets supplied for maximum pressure ratings.
- 2.3. Temperature Rating:** Never exceed the temperature rating of a product. Excessive heat can shorten the life expectancy of a product and result in complete product failure.
- 2.4. Environment:** Many environmental conditions can affect the integrity and suitability of a product for a given application. Pneumatic Division products are designed for use in general purpose industrial applications. If these products are to be used in unusual circumstances such as direct sunlight and/or corrosive or caustic environments, such use can shorten the useful life and lead to premature failure of a product.
- 2.5. Lubrication and Compressor Carryover:** Some modern synthetic oils can and will attack nitrile seals. If there is any possibility of synthetic oils or greases migrating into the pneumatic components check for compatibility with the seal materials used. Consult the factory or product literature for materials of construction.
- 2.6. Polycarbonate Bowls and Sight Glasses:** To avoid potential polycarbonate bowl failures:
 - Do not locate polycarbonate bowls or sight glasses in areas where they could be subject to direct sunlight, impact blow, or temperatures outside of the rated range.
 - Do not expose or clean polycarbonate bowls with detergents, chlorinated hydro-carbons, ketones, esters or certain alcohols.
 - Do not use polycarbonate bowls or sight glasses in air systems where compressors are lubricated with fire resistant fluids such as phosphate ester and di-ester lubricants.



2.7. Chemical Compatibility: For more information on plastic component chemical compatibility see Pneumatic Division technical bulletins Tec-3, Tec-4, and Tec-5

- 2.8. Product Rupture:** Product rupture can cause death, serious personal injury, and property damage.
- Do not connect pressure regulators or other Pneumatic Division products to bottled gas cylinders.
 - Do not exceed the maximum primary pressure rating of any pressure regulator or any system component.
 - Consult product labeling or product literature for pressure rating limitations.

3. PRODUCT ASSEMBLY AND INSTALLATION INSTRUCTIONS

- 3.1. Component Inspection:** Prior to assembly or installation a careful examination of the valves, FRLs or vacuum products must be performed. All components must be checked for correct style, size, and catalog number. DO NOT use any component that displays any signs of nonconformance.
- 3.2. Installation Instructions:** Parker published Installation Instructions must be followed for installation of Parker valves, FRLs and vacuum components. These instructions are provided with every Parker valve or FRL sold, or by calling 1-800-CPARKER, or at www.parker.com.
- 3.3. Air Supply:** The air supply or control medium supplied to Valves, FRLs and Vacuum components must be moisture-free if ambient temperature can drop below freezing

4. VALVE AND FRL MAINTENANCE AND REPLACEMENT INSTRUCTIONS

- 4.1. Maintenance:** Even with proper selection and installation, valve, FRL and vacuum products service life may be significantly reduced without a continuing maintenance program. The severity of the application, risk potential from a component failure, and experience with any known failures in the application or in similar applications should determine the frequency of inspections and the servicing or replacement of Pneumatic Division products so that products are replaced before any failure occurs. A maintenance program must be established and followed by the user and, at minimum, must include instructions 4.2 through 4.9.
- 4.2. Installation and Service Instructions:** Before attempting to service or replace any worn or damaged parts consult the appropriate Service Bulletin for the valve or FRL in question for the appropriate practices to service the unit in question. These Service and Installation Instructions are provided with every Parker valve and FRL sold, or are available by calling 1-800-CPARKER, or by accessing the Parker web site at www.parker.com.
- 4.3. Lockout / Tagout Procedures:** Be sure to follow all required lockout and tagout procedures when servicing equipment. For more information see: OSHA Standard – 29 CFR, Part 1910.147, Appendix A, The Control of Hazardous Energy – (Lockout / Tagout)
- 4.4. Visual Inspection:** Any of the following conditions requires immediate system shut down and replacement of worn or damaged components:
- Air leakage: Look and listen to see if there are any signs of visual damage to any of the components in the system. Leakage is an indication of worn or damaged components.
 - Damaged or degraded components: Look to see if there are any visible signs of wear or component degradation.
 - Kinked, crushed, or damaged hoses. Kinked hoses can result in restricted air flow and lead to unpredictable system behavior.
 - Any observed improper system or component function: Immediately shut down the system and correct malfunction.
 - Excessive dirt build-up: Dirt and clutter can mask potentially hazardous situations.

Caution: Leak detection solutions should be rinsed off after use.

- 4.5. Routine Maintenance Issues:**
- Remove excessive dirt, grime and clutter from work areas.
 - Make sure all required guards and shields are in place.
- 4.6. Functional Test:** Before initiating automatic operation, operate the system manually to make sure all required functions operate properly and safely.
- 4.7. Service or Replacement Intervals:** It is the user's responsibility to establish appropriate service intervals. Valves, FRLs and vacuum products contain components that age, harden, wear, and otherwise deteriorate over time. Environmental conditions can significantly accelerate this process. Valves, FRLs and vacuum components need to be serviced or replaced on routine intervals. Service intervals need to be established based on:
- Previous performance experiences.
 - Government and / or industrial standards.
 - When failures could result in unacceptable down time, equipment damage or personal injury risk.
- 4.8. Servicing or Replacing of any Worn or Damaged Parts:** To avoid unpredictable system behavior that can cause death, personal injury and property damage:
- Follow all government, state and local safety and servicing practices prior to service including but not limited to all OSHA Lockout Tagout procedures (OSHA Standard – 29 CFR, Part 1910.147, Appendix A, The Control of Hazardous Energy – Lockout / Tagout).
 - Disconnect electrical supply (when necessary) before installation, servicing, or conversion.
 - Disconnect air supply and depressurize all air lines connected to system and Pneumatic Division products before installation, service, or conversion.
 - Installation, servicing, and / or conversion of these products must be performed by knowledgeable personnel who understand how pneumatic products are to be applied.
 - After installation, servicing, or conversions air and electrical supplies (when necessary) should be connected and the product tested for proper function and leakage. If audible leakage is present, or if the product does not operate properly, do not put product or system into use.
 - Warnings and specifications on the product should not be covered or painted over. If masking is not possible, contact your local representative for replacement labels.

4.9. Putting Serviced System Back into Operation: Follow the guidelines above and all relevant Installation and Maintenance Instructions supplied with the valve FRL or vacuum component to insure proper function of the system.

Part Number
Index

Safety Guide

Offer of Sale

Part Number Index,
Safety Guide, Offer of Sale



For inventory, lead time, and kit lookup, visit www.pdnplu.com

PARKER-HANNIFIN CORPORATION
OFFER OF SALE

1. **Definitions.** As used herein, the following terms have the meanings indicated.

Buyer:	means any customer receiving a Quote for Products from Seller.
Goods:	means any tangible part, system or component to be supplied by the Seller.
Products:	means the Goods, Services and/or Software as described in a Quote provided by the Seller.
Quote:	means the offer or proposal made by Seller to Buyer for the supply of Products.
Seller:	means Parker-Hannifin Corporation, including all divisions and businesses thereof.
Services:	means any services to be supplied by the Seller.
Software:	means any software related to the Products, whether embedded or separately downloaded.
Terms:	means the terms and conditions of this Offer of Sale or any newer version of the same as published by Seller electronically at www.parker.com/saleterms .

2. **Terms.** All sales of Products by Seller are contingent upon, and will be governed by, these Terms and, these Terms are incorporated into any Quote provided by Seller to any Buyer. Buyer's order for any Products whether communicated to Seller verbally, in writing, by electronic data interface or other electronic commerce, shall constitute acceptance of these Terms. Seller objects to any contrary or additional terms or conditions of Buyer. Reference in Seller's order acknowledgement to Buyer's purchase order or purchase order number shall in no way constitute an acceptance of any of Buyer's terms of purchase. No modification to these Terms will be binding on Seller unless agreed to in writing and signed by an authorized representative of Seller.

3. **Price; Payment.** The Products set forth in Seller's Quote are offered for sale at the prices indicated in Seller's Quote. Unless otherwise specifically stated in Seller's Quote, prices are valid for thirty (30) days and do not include any sales, use, or other taxes or duties. Seller reserves the right to modify prices at any time to adjust for any raw material price fluctuations. Unless otherwise specified by Seller, all prices are F.C.A. Seller's facility (INCOTERMS 2010). All sales are contingent upon credit approval and payment for all purchases is due thirty (30) days from the date of invoice (or such date as may be specified in the Quote). Unpaid invoices beyond the specified payment date incur interest at the rate of 1.5% per month or the maximum allowable rate under applicable law.

4. **Shipment; Delivery; Title and Risk of Loss.** All delivery dates are approximate. Seller is not responsible for damages resulting from any delay. Regardless of the manner of shipment, delivery occurs and title and risk of loss or damage pass to Buyer, upon placement of the Products with the shipment carrier at Seller's facility. Unless otherwise agreed, Seller may exercise its judgment in choosing the carrier and means of delivery. No deferment of shipment at Buyer's request beyond the respective indicated shipping date will be made except on terms that will indemnify, defend and hold Seller harmless against all loss and additional expense. Buyer shall be responsible for any additional shipping charges incurred by Seller due to Buyer's acts or omissions.

5. **Warranty.** The warranty related to the Products is as follows: (i) Goods are warranted against defects in material or workmanship for a period of twelve (12) months from the date of delivery or 2,000 hours of use, whichever occurs first; (ii) Services shall be performed in accordance with generally accepted practices and using the degree of care and skill that is ordinarily exercised and customary in the field to which the Services pertain and are warranted for a period of six (6) months from the completion of the Services by Seller; and (iii) Software is only warranted to perform in accordance with applicable specifications provided by Seller to Buyer for ninety (90) days from the date of delivery or, when downloaded by a Buyer or end-user, from the date of the initial download. All prices are based upon the exclusive limited warranty stated above, and upon the following disclaimer:

DISCLAIMER OF WARRANTY: THIS WARRANTY IS THE SOLE AND ENTIRE WARRANTY PERTAINING TO PRODUCTS. SELLER DISCLAIMS ALL OTHER WARRANTIES, EXPRESS AND IMPLIED, INCLUDING DESIGN, NONINFRINGEMENT, MERCHANTABILITY, AND FITNESS FOR A PARTICULAR PURPOSE. SELLER DOES NOT WARRANT THAT THE SOFTWARE IS ERROR-FREE OR FAULT-TOLERANT, OR THAT BUYER'S USE THEREOF WILL BE SECURE OR UNINTERRUPTED. BUYER AGREES AND ACKNOWLEDGES THAT UNLESS OTHERWISE AUTHORIZED IN WRITING BY SELLER THE SOFTWARE SHALL NOT BE USED IN CONNECTION WITH HAZARDOUS OR HIGH RISK ACTIVITIES OR ENVIRONMENTS. EXCEPT AS EXPRESSLY STATED HEREIN, ALL PRODUCTS ARE PROVIDED "AS IS".

6. **Claims; Commencement of Actions.** Buyer shall promptly inspect all Products upon receipt. No claims for shortages will be allowed unless reported to the Seller within ten (10) days of delivery. Buyer shall notify Seller of any alleged breach of warranty within thirty (30) days after the date the non-conformance is or should have been discovered by Buyer. Any claim or action against Seller based upon breach of contract or any other theory, including tort, negligence, or otherwise must be commenced within twelve (12) months from the date of the alleged breach or other alleged event, without regard to the date of discovery.

7. **LIMITATION OF LIABILITY.** IN THE EVENT OF A BREACH OF WARRANTY, SELLER WILL, AT ITS OPTION, REPAIR OR REPLACE THE NON-CONFORMING PRODUCT, RE-PERFORM THE SERVICES, OR REFUND THE PURCHASE PRICE PAID WITHIN A REASONABLE PERIOD OF TIME. IN NO EVENT IS SELLER LIABLE FOR ANY SPECIAL, INDIRECT, INCIDENTAL OR CONSEQUENTIAL DAMAGES ARISING OUT OF, OR AS THE RESULT OF, THE SALE, DELIVERY, NON-DELIVERY, SERVICING, NON-COMPLETION OF SERVICES, USE, LOSS OF USE OF, OR INABILITY TO USE THE PRODUCTS OR ANY PART THEREOF, LOSS OF DATA, IDENTITY, PRIVACY, OR CONFIDENTIALITY, OR FOR ANY CHARGES OR EXPENSES OF ANY NATURE INCURRED WITHOUT SELLER'S WRITTEN CONSENT, WHETHER BASED IN CONTRACT, TORT OR OTHER LEGAL THEORY. IN NO EVENT SHALL SELLER'S LIABILITY UNDER ANY CLAIM MADE BY BUYER EXCEED THE PURCHASE PRICE PAID FOR THE PRODUCTS.

8. **Loss to Buyer's Property.** Any designs, tools, patterns, materials, drawings, confidential information or equipment furnished by Buyer or any other items which are or become Buyer's property, will be considered obsolete and may be destroyed by Seller after two (2) consecutive years have elapsed without Buyer ordering the Products manufactured using such property. Seller shall not be responsible for any loss or damage to such property while it is in Seller's possession or control.

9. **Special Tooling.** Special Tooling includes but is not limited to tooling, jigs, fixtures and associated manufacturing equipment acquired or necessary to manufacture Products. A tooling charge may be imposed for any Special Tooling. Such Special Tooling shall be and remain Seller's property notwithstanding payment of any charges by Buyer. In no event will Buyer acquire any interest in Special Tooling belonging to Seller that is utilized in the manufacture of the Products, even if such Special Tooling has been specially converted or adapted for such manufacture and notwithstanding any charges paid by Buyer. Unless otherwise agreed, Seller has the right to alter, discard or otherwise dispose of any Special Tooling or other property in its sole discretion at any time.

10. **Security Interest.** To secure payment of all sums due, Seller retains a security interest in all Products delivered to Buyer and, Buyer's acceptance of these Terms is deemed to be a Security Agreement under the Uniform Commercial Code. Buyer authorizes Seller as its attorney to execute and file on Buyer's behalf all documents Seller deems necessary to perfect its security interest.

11. **User Responsibility.** The Buyer through its own analysis and testing, is solely responsible for making the final selection of the Products and assuring that all performance, endurance, maintenance, safety and warning requirements of the application of the Products are met. The Buyer must analyze all aspects of the application and follow applicable industry standards, specifications, and other technical information provided with the Product. If Seller provides Product options based upon data or specifications provided by the Buyer, the Buyer is responsible for determining that such data and specifications are suitable and sufficient for all applications and reasonably foreseeable uses of the Products. In the event the Buyer is not the end-user, Buyer will ensure such end-user complies with this paragraph.

12. **Use of Products; Indemnity by Buyer.** Buyer shall comply with all instructions, guides and specifications provided by Seller with the Products. **Unauthorized Uses.** If Buyer uses or resells the Products for any uses prohibited in Seller's instructions, guides or specifications, or Buyer otherwise fails to comply with Seller's instructions, guides and specifications, Buyer acknowledges that any such use, resale, or non-compliance is at Buyer's sole risk. Buyer shall indemnify, defend, and hold Seller harmless from any losses, claims, liabilities, damages, lawsuits, judgments and costs (including attorney fees and defense costs), whether for personal injury, property damage, intellectual property infringement or any other claim, brought by or incurred by Buyer, Buyer's employees, or any other person, arising out of: (a) improper selection, application, design, specification or other misuse of Products provided by Seller; (b) any act or omission, negligent or otherwise, of Buyer; (c) Seller's use of patterns, tooling, equipment, plans, drawings, designs or specifications or other information or things furnished by Buyer; (d) damage to the Products from an external cause, repair or attempted repair by anyone other than Seller, failure to follow instructions, guides and specifications provided by Seller, use with goods not provided by Seller, or opening, modifying, deconstructing or tampering with the Products for any reason; or (e) Buyer's failure to comply with these Terms. Seller shall not indemnify Buyer under any circumstance except as otherwise provided in these Terms.

13. **Cancellations and Changes.** Buyer may not cancel or modify any order for any reason, except with Seller's written consent and upon terms that will indemnify, defend and hold Seller harmless against all direct, incidental and consequential loss or damage. Seller, at any time, may change Product features, specifications, designs and availability.

14. **Limitation on Assignment.** Buyer may not assign its rights or obligations without the prior written consent of Seller.

15. **Force Majeure.** Seller does not assume the risk and is not liable for delay or failure to perform any of Seller's obligations by reason of events or circumstances beyond its reasonable control ("Events of Force Majeure"). Events of Force Majeure shall include without limitation: accidents, strikes or labor disputes, acts of any government or government agency, acts of nature, delays or failures in delivery from carriers or suppliers, shortages of materials, or any other cause beyond Seller's reasonable control.

16. **Waiver and Severability.** Failure to enforce any provision of these Terms will not invalidate that provision; nor will any such failure prejudice Seller's right to enforce that provision in the future. Invalidation of any provision of these Terms by legislation or other rule of law shall not invalidate any other provision herein and, the remaining provisions will remain in full force and effect.

17. **Termination.** Seller may terminate any agreement governed by or arising from these Terms for any reason and at any time by giving Buyer thirty (30) days prior written notice. Seller may immediately terminate, in writing, if Buyer: (a) breaches any provision of these Terms (b) appoints a trustee, receiver or custodian for all or any part of Buyer's property (c) files a petition for relief in bankruptcy on its own behalf, or one filed by a third party (d) makes an assignment for the benefit of creditors; or (e) dissolves its business or liquidates all or a majority of its assets.

18. **Ownership of Software.** Seller retains ownership of all Software supplied to Buyer hereunder. In no event shall Buyer obtain any greater right in and to the Software than a right in the nature of a license limited to the use thereof and subject to compliance with any other terms provided with the Software.

19. **Indemnity for Infringement of Intellectual Property Rights.** Seller is not liable for infringement of any patents, trademarks, copyrights, trade dress, trade secrets or similar rights ("Intellectual Property Rights") except as provided in this Section. Seller will defend at its expense and will pay the cost of any settlement or damages awarded in an action brought against Buyer based on a third party claim that one or more of the Products sold hereunder infringes the Intellectual Property Rights of a third party in the country of delivery of the Products by the Seller to the Buyer. Seller's obligation to defend and indemnify Buyer is contingent on Buyer notifying Seller within ten (10) days after Buyer becomes aware of any such claim, and Seller having sole control over the defense of the claim including all negotiations for settlement or compromise. If one or more Products sold hereunder is subject to such a claim, Seller may, at its sole expense and option, procure for Buyer the right to continue using the Products, replace or modify the Products so as to render them non-infringing, or offer to accept return of the Products and refund the purchase price less a reasonable allowance for depreciation. Seller has no obligation or liability for any claim of infringement: (i) arising from information provided by Buyer; or (ii) directed to any Products provided hereunder for which the designs are specified in whole or part by Buyer; or (iii) resulting from the modification, combination or use in a system of any Products provided hereunder. The foregoing provisions of this Section constitute Seller's sole and exclusive liability and Buyer's sole and exclusive remedy for such claims of infringement of Intellectual Property Rights.

20. **Governing Law.** These Terms and the sale and delivery of all Products are deemed to have taken place in, and shall be governed and construed in accordance with, the laws of the State of Ohio, as applicable to contracts executed and wholly performed therein and without regard to conflicts of laws principles. Buyer irrevocably agrees and consents to the exclusive jurisdiction and venue of the courts of Cuyahoga County, Ohio with respect to any dispute, controversy or claim arising out of or relating to the sale and delivery of the Products.

21. **Entire Agreement.** These Terms, along with the terms set forth in the main body of any Quote, forms the entire agreement between the Buyer and Seller and constitutes the final, complete and exclusive expression of the terms of sale. In the event of a conflict between any term set forth in the main body of a Quote and these Terms, the terms set forth in the main body of the Quote shall prevail. All prior or contemporaneous written or oral agreements or negotiations with respect to the subject matter shall have no effect. These Terms may not be modified unless in writing and signed by an authorized representative of Seller.

22. **Compliance with Laws.** Buyer agrees to comply with all applicable laws, regulations, and industry and professional standards, including those of the United States of America, and the country or countries in which Buyer may operate, including without limitation the U.S. Foreign Corrupt Practices Act ("FCPA"), the U.S. Anti-Kickback Act ("Anti-Kickback Act"), U.S. and E.U. export control and sanctions laws ("Export Laws"), the U.S. Food Drug and Cosmetic Act ("FDCA"), and the rules and regulations promulgated by the U.S. Food and Drug Administration ("FDA"), each as currently amended. Buyer agrees to indemnify, defend, and hold harmless Seller from the consequences of any violation of such laws, regulations and standards by Buyer, its employees or agents. Buyer acknowledges that it is familiar with all applicable provisions of the FCPA, the Anti-Kickback Act, Export Laws, the FDCA and the FDA and certifies that Buyer will adhere to the requirements thereof and not take any action that would make Seller violate such requirements. Buyer represents and agrees that Buyer will not make any payment or give anything of value, directly or indirectly, to any governmental official, foreign political party or official thereof, candidate for foreign political office, or commercial entity or person, for any improper purpose, including the purpose of influencing such person to purchase Products or otherwise benefit the business of Seller. Buyer further represents and agrees that it will not receive, use, service, transfer or ship any Product from Seller in a manner or for a purpose that violates Export Laws or would cause Seller to be in violation of Export Laws.