

CPS Continuous Position Sensors

Value Proposition

Many applications require more than just end of stroke sensing of an actuator, but traditional methods of continuous sensing are expensive to implement. Parker's CPS (Continuous Position Sensing) series of the P8S sensor family enables quick precise and contactless continuous position sensing of a piston in standard acutators. This offers an outstanding price/performance ratio.

Product Overview

P8S Continuous Position Sensors detect continuously the position of the piston of pneumatic actuators using a direct, non-contact technology along the length of the sensors, measuring ranges from 32 to 256 mm. They can be mounted in T-slots without the need for additional accessories for cylinders build with common T-slots dimensions. Mounting on other cylinder types ie round cylinders type is possible with adaptors. The sensor settings can be adjusted during installation and during operation later on, using a teach button or, depending on the variant, using IO-Link.

The sensors continuously supply data via analogue outputs or IO-Link. Analogue position sensors, for current or voltage, have a voltage output of 0 V ... 10 V as well as a current output of 4 mA ... 20 mA. It enables flexible machine concepts and making it possible to solve tasks in areas such as quality monitoring and process control in conjunction with pneumatic cylinders. This continuous transfer of position data upgrades the functionality of the pneumatic cylinders by making them more intelligent and as a result, more versatile.

Technical Data

Cylinder type:	Profile with T-slot
Installation:	Drop in, fixed by allen key 1,5 mm
Measuring range:	32 to 256 mm depending on type ¹⁾
Housing length:	45 to 269 mm depending on type
Output Function:	Analog IO-Link
Analog output (voltage):	0 to 10 V -
Analog output (current):	4 to 20 mA -
Teach-in:	Yes
Enclosure rating:	IP67 (according to EN 60529)
Supply Voltage: ²⁾	15 to 30 V DC
Power consumption: ³⁾	<= 22 mA (analogue) <= 25 ma (IO-Link)
Max load resistance: ⁴⁾	<= 500 Ω
Min load resistance: ⁵⁾	<= 2 kΩ
Protection class:	III
Time delay before availability:	1,5 s
Required magnetic field sensitivity:	3 mT / -2 mT (analog) 3 mT (IO-Link)
Resolution: ⁶⁾	0,03% full scale range (max >=0,05 mm)
Linearity error: ⁷⁾	0,3 mm
Repeat accuracy: ⁸⁾	0,06% full scale range (>= 0,1 mm)
Sampling rate: ⁹⁾	1 ms
Indication LED color:	Yellow (analog)
Reserve polarity protection:	Yes (analog)
Short circuit protection:	Yes (analog)
Ambient operating temperature range:	-20 to +70 °C (PUR cable)
Shock and vibration resistance:	30 g 11 ms / 10 ... 55 Hz, 1 mm
EMC: ¹⁰⁾	According to EN 60947-5-2
International standard:	CE C UL US CCC (not applicable) RoHs IO-Link
UL file No:	On request
Housing material:	Plastic polyamid PA12
Screw material:	Stainless steel
Cable material:	PUR (Polyurethane)
Conductor cross-section:	0,08 mm ²
Connector:	M12 (IO-Link) or M8 (analog)



- ¹⁾ ± 1 mm
- ²⁾ Reverse-polarity protected, operation in short-circuit protected network: max. 8 A.
- ³⁾ Without load
- ⁴⁾ Power output, at 24 V
- ⁵⁾ Voltage output
- ⁶⁾ FSR: Full Scale Range; max. measuring range.
- ⁷⁾ At 25 °C, linearity error (maximum deviation) depending on response curve and minimal deviation function.
- ⁸⁾ At 25 °C, repeatability magnet movement in one direction.
- ⁹⁾ Only in standard mode, not in IO-Link mode.
- ¹⁰⁾ The analogue measured value can deviate under transient conditions.

Selection Guide

Drop-in Sensors

Solid State / Reed Sensors

Weld Immune Sensors

Cordset / Connect Block

Proximity Sensors

CPS Smart Sensing

Electronic Sensors



For inventory, lead time, and kit lookup, visit www.pdnplu.com

Ordering Information

Drop in T-slot, Turn, Screw, it's done

Output	Measuring length	Configuration option	Part number	Weight [g]	For product series
Analog	32 mm	Teach Button	P8SAGACHA	16	With T-slot groove *
	64 mm		P8SAGACHB	26	
	128 mm		P8SAGACHD	46	
	192 mm		P8SAGACHF	66	
	256 mm		P8SAGACHH	86	
IO-Link	32 mm	Teach Button or IO-Link parameter	P8SAGHMHA	20	With T-slot groove *
	64 mm		P8SAGHMHB	30	
	128 mm		P8SAGHMHD	50	
	192 mm		P8SAGMHMF	70	
	256 mm		P8SAGMHMH	90	

* Required magnetic field sensitivity: 3mT / -2 mT (Analog) / 3mT (IO-Link)

Note:

PUR cable with M12 (IO-Link) or M8 (Analog) male connector knurled nut, 4-pin, 0,3 meter length. Please consult Parker Pneumatic Division for measuring range 96, 160 & 224 mm.

P8S Sensor

			Part number	
L1	L2 *	L3	Analog	IO-Link
45	32	40	P8SAGACHA	P8SAGHMHA
77	64	72	P8SAGACHB	P8SAGHMHB
141	128	136	P8SAGACHD	P8SAGHMHD
205	192	200	P8SAGACHF	P8SAGMHMF
269	256	264	P8SAGACHH	P8SAGMHMH

*L2 equal to the measuring range

Note:

PUR cable with M12 (IO-Link) or M8 (Analog) male connector knurled nut, 4-pin, 0,3 meter length. Please consult Parker Pneumatic Division for measuring range 96, 160 & 224 mm.

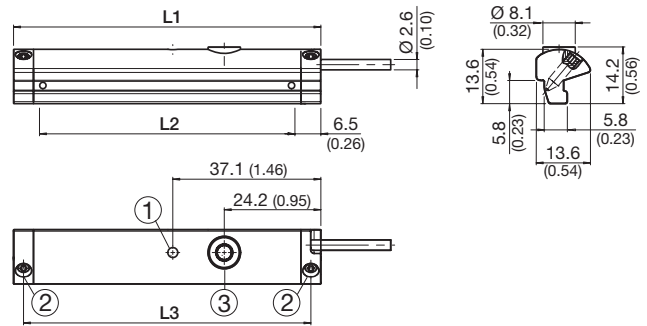

- ① Function indicator
- ② Fixing screw
- ③ Teach-in button

Dimensions in mm (inch)

Connection type and diagram

IO Link version

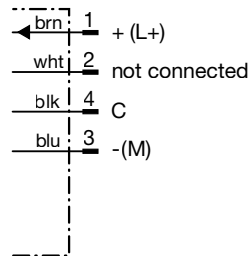

PUR 0.3 meter length with M12 male connector knurled nut, 4-pin

Analog version

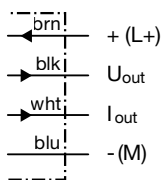

PUR 0.3 meter length with M8 male connector knurled nut, 4-pin

Without Adaptor

Direct drop-in T-slot
T-slot dimensions [mm ± 0.1]

- A 5.55
- B 3.40
- C 6.80
- D 4.80

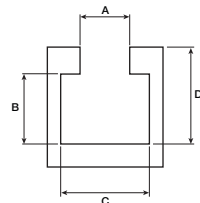

- 1) Pivot sensor into the slot
- 2) Teach the CPS unit the desired measuring range
- 3) Tighten set screws

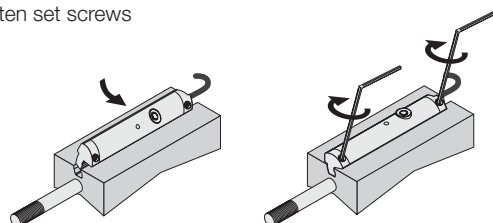

Mountings

All mountings can be moved on the cylinder body before screwing in place and then putting sensors in the slots. Dimensions in mm (inch)

Parker Cylinder Series	Mounting Bracket
P1A (ISO 6432)	P8S-TMC0+
P1D (ISO 6431)	None
P1D (Tie-Rod)	P8S-TMAOX
OSP (Rodless)	Consult factory
P1P (Compact)	None
P5T (Thrust)	None
4MA (NFPA)	None
4MA (6"-8" bore)	P8S-TMAOX
SRM (Round)	P8S-TMC0+

- + Use "1" for bore size under 1-1/8" (32mm)
- Use "2" for 1-1/8" (32mm) to 2-1/2" (63mm)
- Use "3" for 3" (80mm) to 4" (100mm)
- ** Parker recommends to use 2 mounting brackets for CPS 64mm and longer

P8S-TMC01, 02 & 03

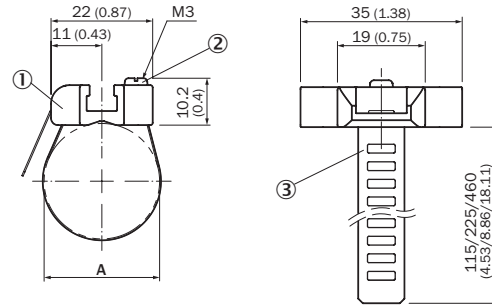

- ① Sensor adapter with T-Slot
- ② Fixing screw
- ③ Strap

P8S-TMAOX

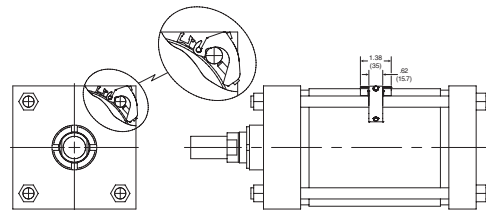

Tie Rod Bracket Assembly is necessary for Global and Mini-Global Sensor installation on all tie rod construction cylinders. This includes all Intermediate Trunnion mounts (Style DD or MT4); and all 6"-8" bore Sensors and bracket assemblies must be ordered separately.

Part number P8S-TMAOX fits 1-1/2" to 8" bores and 32-200mm bores for Global Sensors

M8 Female Cables

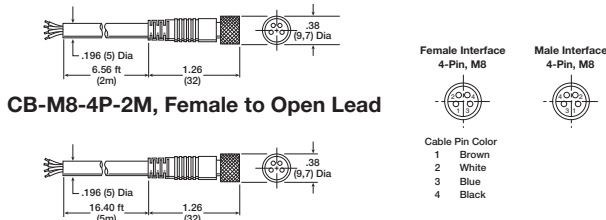

CB-M8-4P-2M, Female to Open Lead

CB-M8-4P-5M, Female to Open Lead

Connector	Contacts	Length	Cover	Part number
M8 female	4	2m	PUR	CB-M8-4P-2M
M8 female	4	5m	PUR	CB-M8-4P-5M

M12 A-code Cables

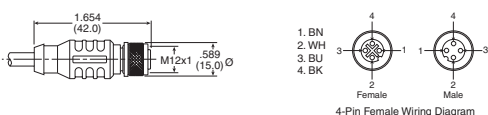

RKC Female Sockets

Description	Part number
4-pin female to flying lead cable, PVC	RKC 4.4T-*
4-pin female to 4-pin male cable, PVC	RKC 4.4T-*-RSC 4.4T

Where * = 1, 2, 4 meter standard lengths



For inventory, lead time, and kit lookup, visit www.pdnplu.com

Selection Guide
 Drop-in Sensors
 Solid State / Reed Sensors
 Weld Immune Sensors
 Cordset / Connect Block
 Proximity Sensors
 CPS Smart Sensing
 Electronic Sensors