



Excellence Through Innovation

PGI International, Ltd.
16101 Vallen Drive—Houston, Texas 77041
(713) 466-0056 or (800) 231-0233
www.pgiint.com

Form IOM-HE-PF1, Rev. 02

Installation, Operation & Maintenance Instructions for Hot-Shot Heated Enclosures with a Model PF1 Sample System



Table of Contents

I. Overview	
Hot-Shot Heated Enclosure.....	3
Finned Sample Probes	4
II. Installation	
Hot-Shot Heated Enclosure with a PGI Sample Probe	5
Sample Cylinder Installation.....	9
Sample Cylinder Change-Out	11
III. Cartridge Filter Unit (CFU)	
Overview	12
Approximate Filter Life	12
Filter Replacement Instructions	13
IV. Catalytic Heater	
Specifications/Orifice Conversion Kits	16
External Gas Supply	17
Start-Up.....	18

I. Overview

Hot-Shot Heated

The PGI Hot-Shot Heated Enclosure is designed to comply with API 14.1—Natural Gas Fluids Measurement. The enclosure will maintain the temperature of your sampling system at or between 100° to 140°F. The following illustrations and instructions will assist you in installing and maintaining your heated enclosure.

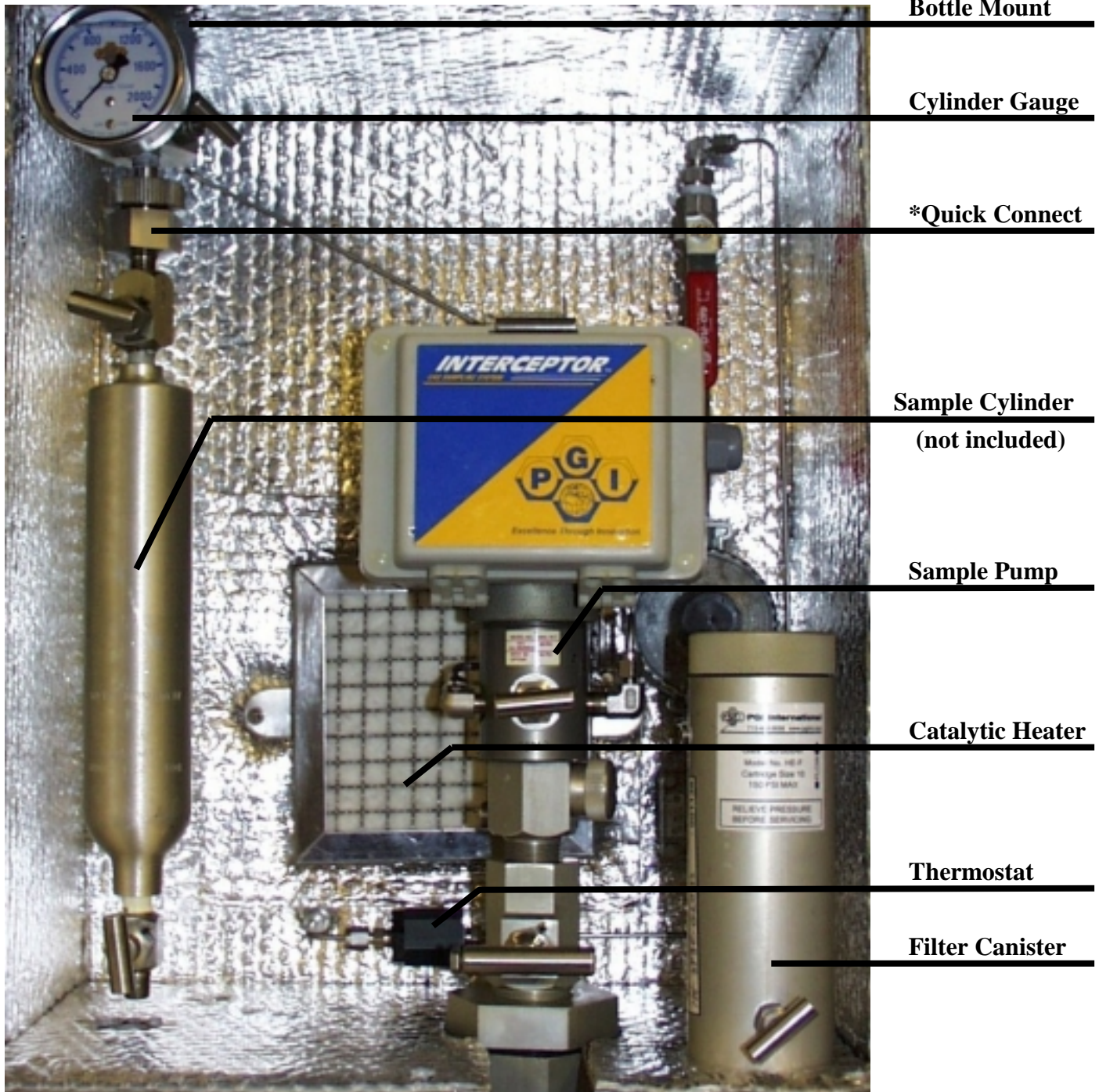

*To order additional Cylinder-side Quick Connect Nuts, reference **Part Number HE-037-10** (for Carbon Steel) or **HE-037-C0** (for 316 Stainless Steel).

I. Overview (cont'd.)

Finned Sample Probes

The heart of any sampling system is the sample probe. PGI's sample probes are constructed of hard-anodized aluminum. Aluminum is capable of transferring temperature 12 times faster than stainless steel. As illustrated, the probe section is finned, increasing the probe surface area in contact with the gas and enhancing its ability to transfer as much of the flowing gas temperature to the probe as possible.

Begin by making sure you have selected the proper probe length for your application. The probe should be of a length that will place its tip somewhere in the center third of the flowing stream. For example, for an 8" pipeline, select a probe that extends from 2.6" to 5.3" into the pipeline. See the table below to help determine the proper probe length for your application.

PGI offers probe lengths of 3", 6", and 10", available with male NPT connection thread sizes of 1/2", 3/4", and 1".

Note: A 10" probe is the maximum length required for pipelines over 20".

PGI also offers **Probe Adapters** for applications which require the use of an existing probe. PGI Customer Probe Adapters are typically used on pipelines under 4" in diameter. See form number **IOM-HE-P-L01** for part numbers and installation instructions for Heated Enclosure Customer Probe Adapters.

Pipeline Dia.	Probe Length	Male NPT Size	Part Numbers
4" to 6"	3"	1/2"	HE-P-L03 (shown)
		3/4"	HE-P-L03N3
		1"	HE-P-L03N4
8" to 14"	6"	1/2"	HE-P-L06
		3/4"	HE-P-L06N3
Over 14"	10"	1/2"	HE-P-L10
		3/4"	HE-P-L10N3

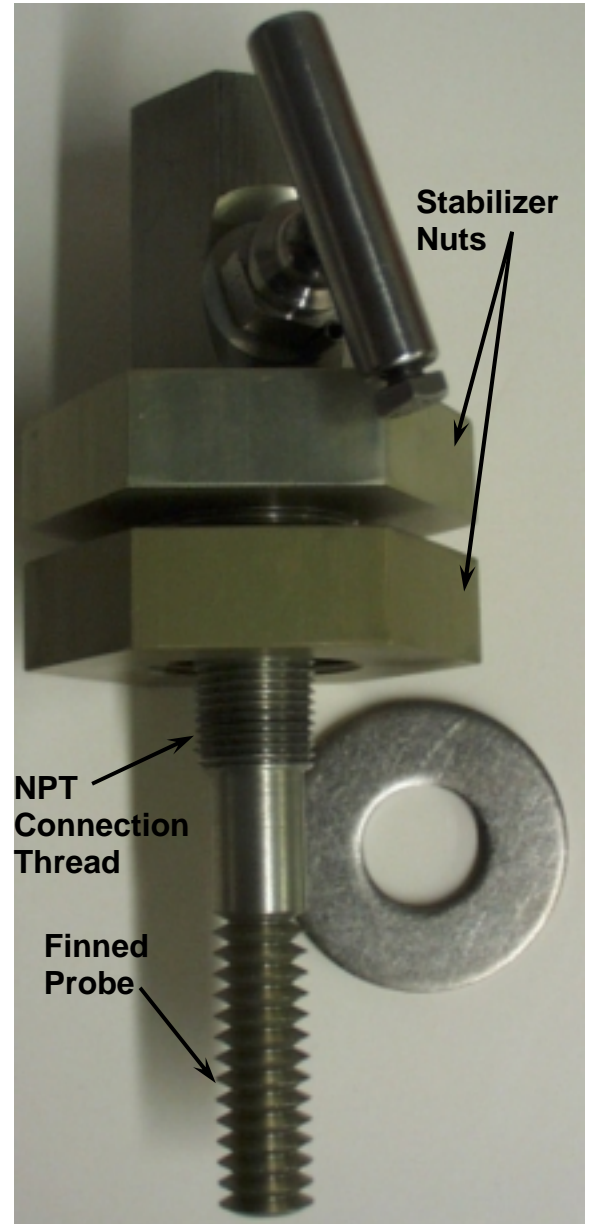

Installing a competitor's Sampler in a PGI Heated Enclosure will require field modifications to the sample probe and the competitor pump tubing.

CAUTION

REMOVE ALL PIPELINE PRESSURE FROM THE SAMPLE PROBE AND THE SAMPLER BEFORE SERVICING.

FAILURE TO DO SO MAY RESULT IN SERIOUS INJURY OR DEATH.

II. Installation

Hot-Shot Heated Enclosure with a PGI Sample Probe

These instructions apply to Heated Enclosures with the following sample probes:

HE-P-L02	HE-P-L03	HE-P-L06	HE-P-L10
HE-P-L02N3	HE-P-L03N3	HE-P-L06N3	HE-P-L10N3
	HE-P-L03N4		

Remove the Pump and Sample Probe from the Heated Enclosure:

- 1) Using a 7/16" wrench, remove the tubing fitting from the elbow on the right side of the Sample Pump. Do not remove the elbow.

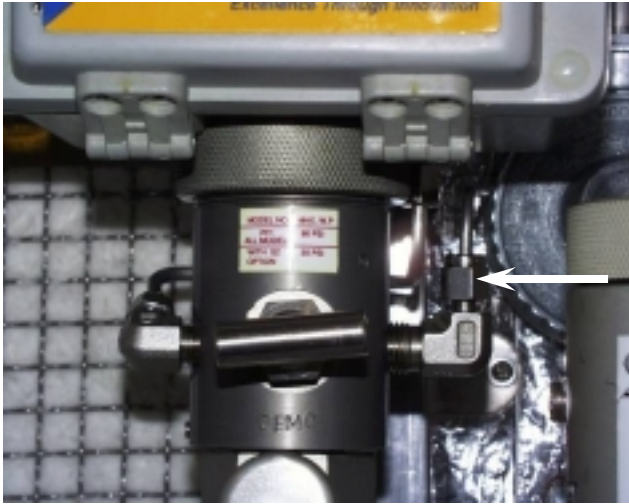

Fitting Location



- 2) If your Heated Enclosure was ordered with the Low Pressure Option (for Sample Sites operating at 5 PSIG or less), go to step 3.

For standard PF1 Heated Enclosures, remove the tubing fitting from the elbow on the Lower Pump Body. Do not remove the elbow.

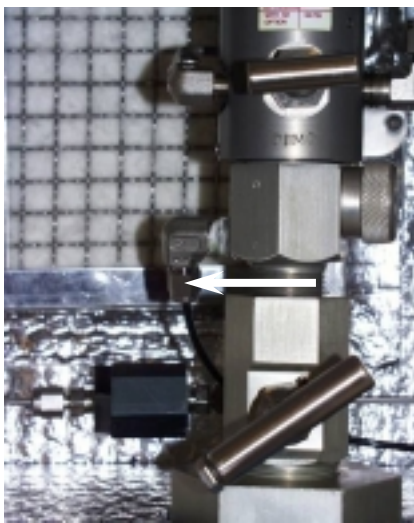

Fitting Location



II. Installation (cont'd.)

- 3) Carefully lay the Enclosure on its back and loosen the bottom Stabilizer Nut. Loosen the nut enough so that a large gap is created between the two Stabilizer Nuts.



- 4) Carefully remove the Pump and Probe from the enclosure without causing damage to the insulation.

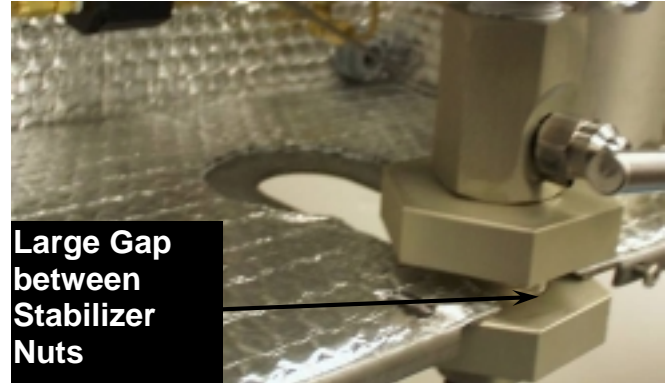

Note: A flat washer is included with all 1/2" NPT Sample Probes. The washer is used to add stability to the Heated Enclosure unit once it is mounted atop the probe.

Sample Probe numbers ending in "N3" and "N4" (3/4" and 1" NPTs) are more stable by design and do not require the washer. Installation of probes with the larger NPTs should be performed as instructed below, but without the use of the washer.

- 5) Place the washer on top of the thread-o-let. (The washer is not required when installing Sample Probes containing the option code "N3" or "N4".)

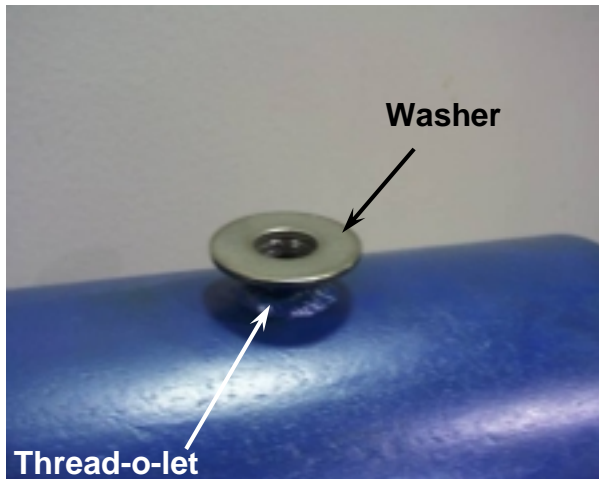

- 6) Turn the stabilizer nuts all the way up to the hex portion of the Sample Probe body, as shown below.

- 7) Apply thread sealant to the NPT thread. Avoid using an excessive amount of sealant.

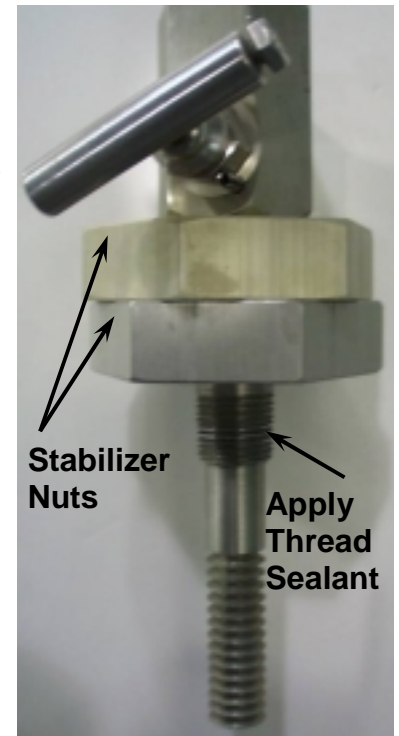

II. Installation (cont'd.)

- 8) Prior to installing the Sample Probe and Pump to the sample site, be sure the valve handle on the Sample Probe is CLOSED.

Close Probe Valve



- 9) Place the finned portion of the Sample Probe through the washer and into the thread-o-let.



- 10) Using a wrench on the hex portion of the probe body, tighten the Sample Probe into the thread-o-let.



Note: Make sure that the valve handle will be accessible and operational once the Heated Enclosure is installed.

- 11) With a large pipe wrench, tighten the bottom stabilizer nut against the washer, creating a gap

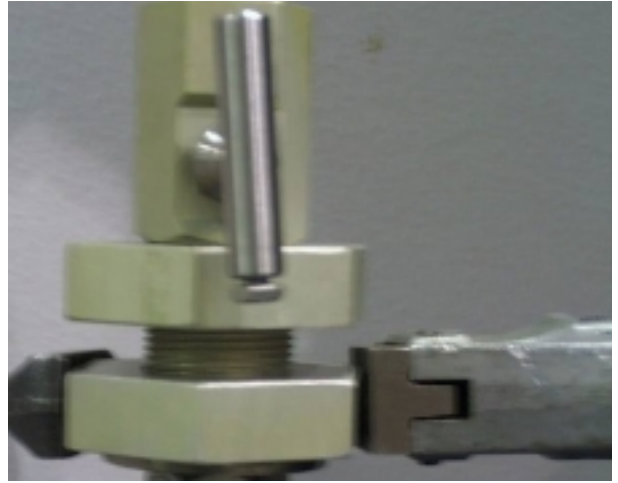

- 12) Lift the Heated Enclosure and slide it between the two Stabilizer Nuts.

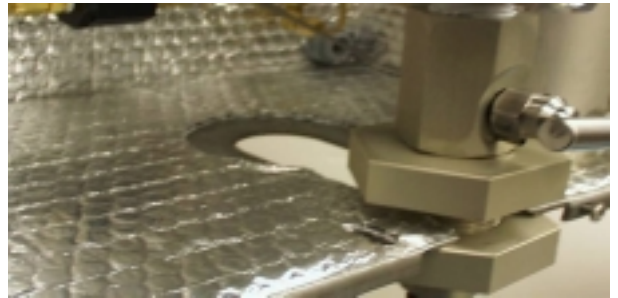

- 13) With the Heated Enclosure resting on the bottom Stabilizer Nut, spin the top Stabilizer Nut down onto the Enclosure and tighten with large pipe wrench. Use caution to avoid damage to the insulation.



II. Installation (cont'd.)

14) Reconnect the tubing fitting to the elbow on the right side of the Sample Pump.

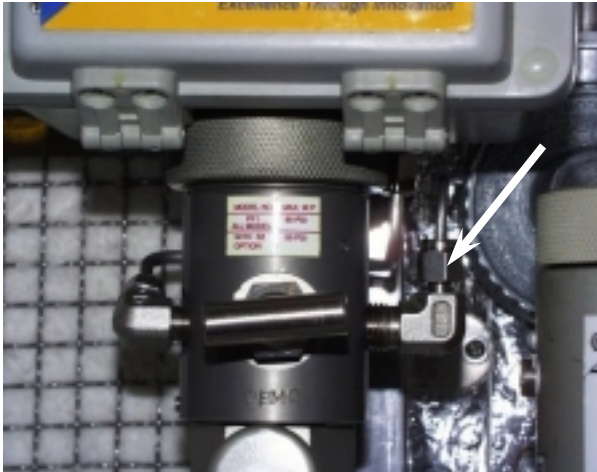

15) For standard PF1 Heated Enclosures, reconnect the tubing fitting to the elbow on the Lower Pump Body.

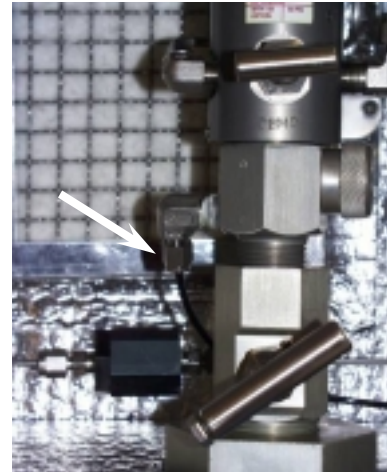

16) Install the Sample Bottle according to the installation instructions found on page 9. The Sample Bottle is not included.

**These Holes
Should be
Plugged**



To achieve the most suitable conditions, the installer should plug the holes in the bottom of the Heated Enclosure. This will prevent cold air washing over the bottle or next to the probe. The openings around the heater will allow sufficient air flow for proper heater operation.

After the Sample Cylinder has been installed, full line pressure may be introduced to the Sample System.

II. Installation (cont'd.)

Installation of Sample Cylinder

PGI's Hot-Shot Heated Enclosure is outfitted with a Quick Connect bottle mount that is designed to make Sample Cylinder installation quick and easy. Additional Cylinder-side Adapters may be purchased separately to be installed on change-out cylinders. Other connectors types are available upon request. See page 3 for part numbers.

To install your Sample Cylinder:

1. Hold the Adapter in place while turning the Quick Connect Nut counter-clockwise by hand.

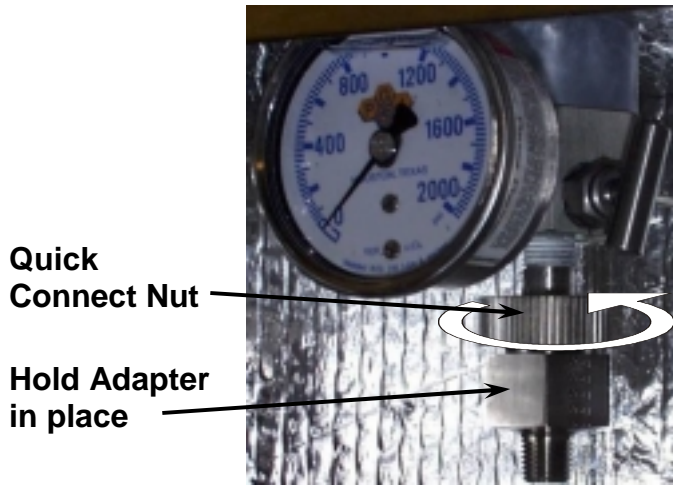

2. Apply thread sealant to the Adapter threads and install onto Cylinder Valve.

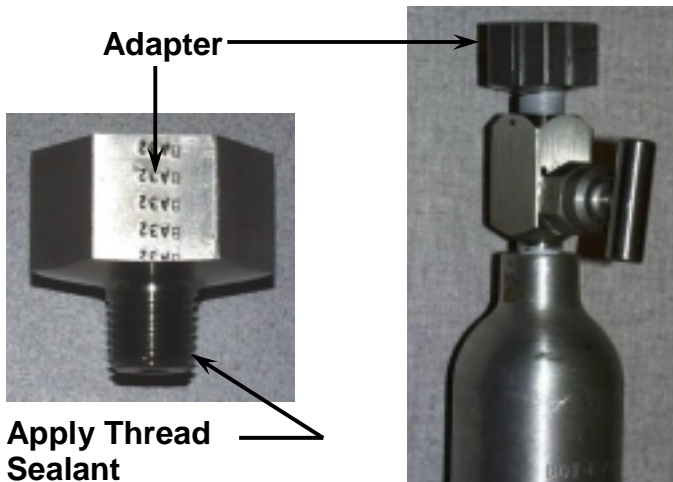

3. Holding the Quick Connect Nut up, push the Adapter onto the Connector Stem.

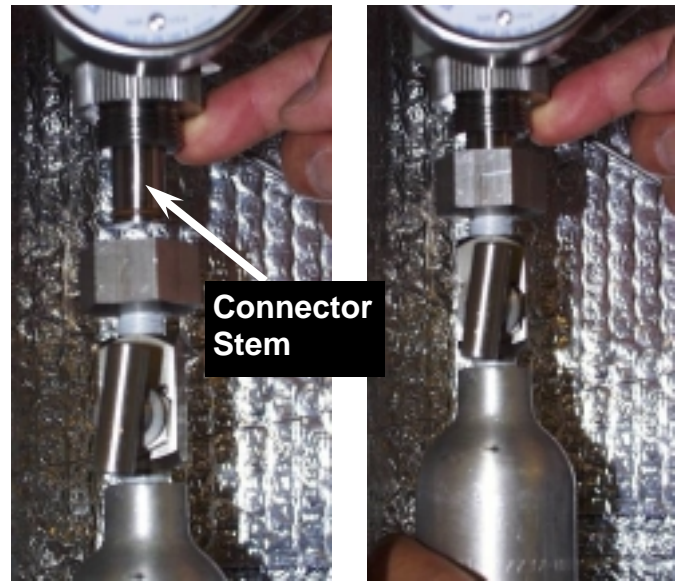

4. Screw the Quick Connect Nut into the Adapter, finger-tight only.



II. Installation (cont'd.)

NOTE: Each of the valves referenced here are equipped with a right-hand thread. Turn clockwise to close and counter-clockwise to open.

- 5) Close the Vent Valve ①.
- 6) Open the Purge Valve ②.
(This will load the sample line with line pressure gas. The pressure gauge ③ will indicate line pressure.)
- 7) Open the Top Valve on the Sample Cylinder ④.
(This will allow line pressure gas to enter the cylinder)
- 8) Use your company policy for Fill and Empty Procedure to purge all air from the Sample Cylinder. See API 14.1 for recommendations on purging.
Note: Only cycle the cylinder valves, ④ & ⑤, for the Fill and Empty Procedure. DO NOT cycle the Sampler Purge Valve ② for this procedure.
- 9) After the Fill and Empty Procedure has been performed, close the Purge Valve ②.
- 10) With line pressure on the cylinder, check all fittings for leaks.
- 11) Slowly open the Bottom Valve on the Sample Cylinder ⑤ until only about one PSIG is left on the cylinder.
- 12) Power "ON" the Sampler to start sample collecting. Refer to PGI INTERCEPTOR™ Gas Sampling System I.O.& M. Manual for Sampler Operation Instructions.

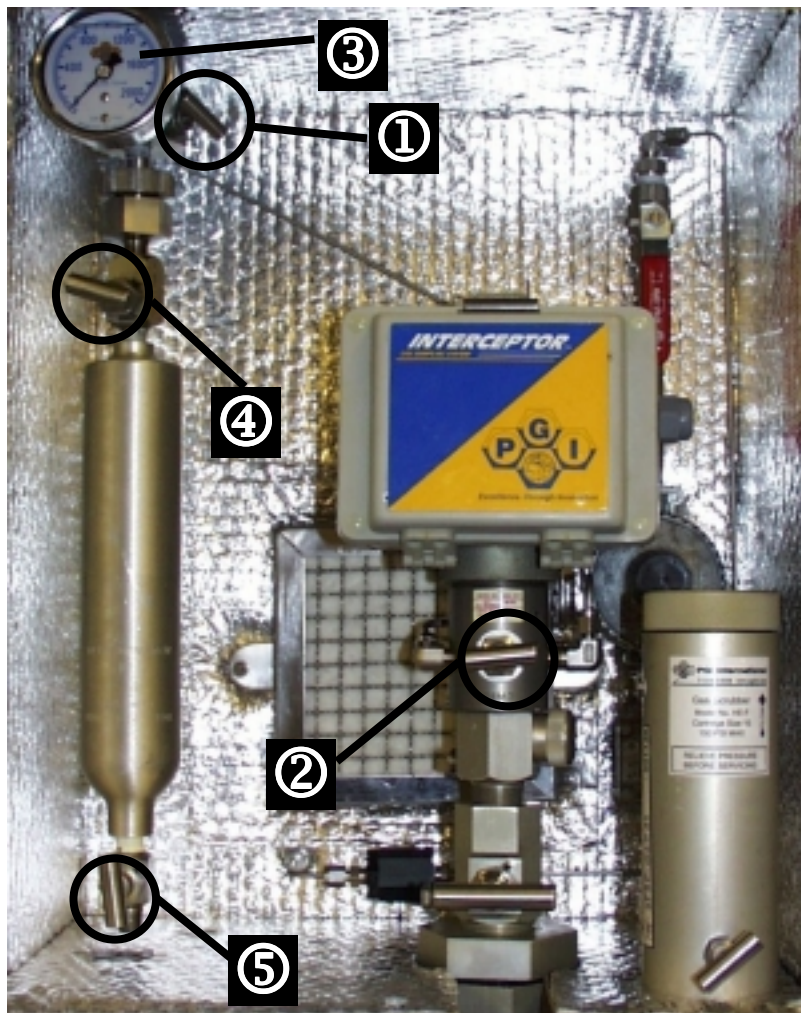

II. Installation (cont'd.)

Sample Cylinder Change-Out

The Heated Enclosure is designed to keep the temperature of the sample gas and the equipment above the hydrocarbon dew point, thereby allowing a more representative sample to be taken. In order to maintain these conditions, it may be desirable to have 3 sample cylinders for each sample site, each with a Cylinder-side Adapter installed on the Top Valve. See page 3 for part numbers.

While cylinder ① is in use, the change-out cylinder ② may be left inside the heated enclosure, maintained at a desirable temperature.

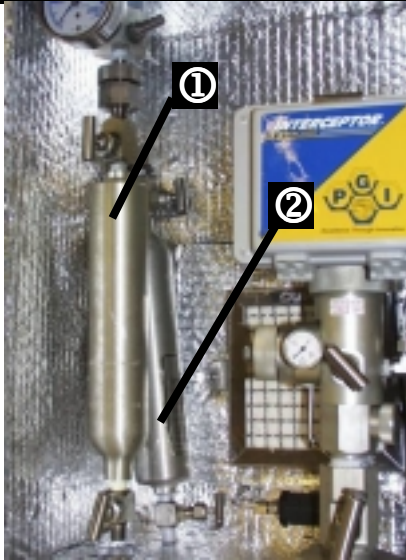

When cylinder ① is removed, the change-out cylinder ② may be installed and a third cylinder may be left as the next change-out cylinder ③.

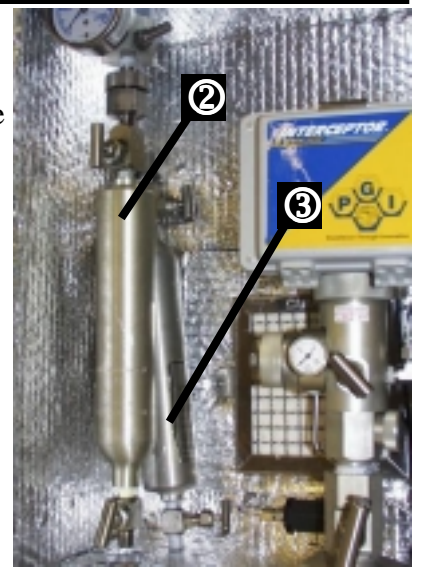

To remove the cylinder after sample has been taken . . .

- 1) Close the Top Valve on the Sample Cylinder ①.
- 2) Open the Bleeder Valve ②.
(This will release line pressure between the Gauge Manifold and the Sampler, as indicated by the pressure gauge ③.)
Note: The Quick Connect Nut ④ can not be removed under line pressure. The pressure gauge ③ must read “zero” before attempting to remove the cylinder.

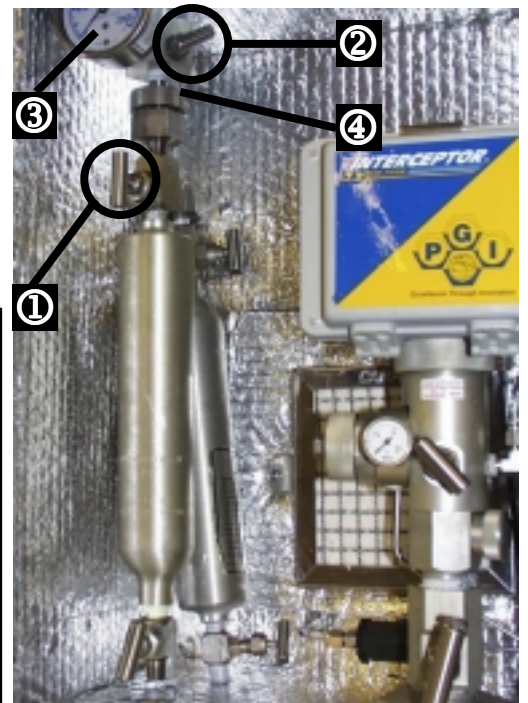

- 3) After pressure has been bled, hold the cylinder up while loosening the Quick Connect Nut ④.

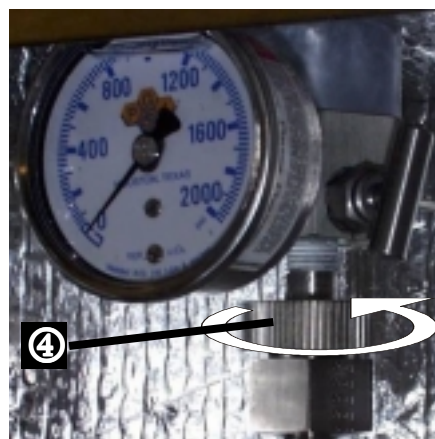

- 4) To install the change-out cylinder, see **Installation of Sample Cylinder** on page 6.

III. Cartridge Filter Unit (CFU)

Overview

The CFU removes contaminants, moisture, and H₂S from the heater gas supply. The catalytic heater requires a clean, dry fuel source and using the CFU can extend the life of the catalyst. The CFU is outfitted with an AV106S-V-H8 bonnet assembly and a 1/8" NPT drain port to vent any liquids separated from the gas supply.

The gas supply from the regulator pump enters the CFU through the 1/4" NPT port on the backside, bottom portion of the scrubber canister. As the gas travels upward through the filter, contaminants are trapped and liquids are dropped to the bottom. The filtered gas is allowed to continue upward to the 1/8" NPT outlet port on the backside, top portion of the canister.

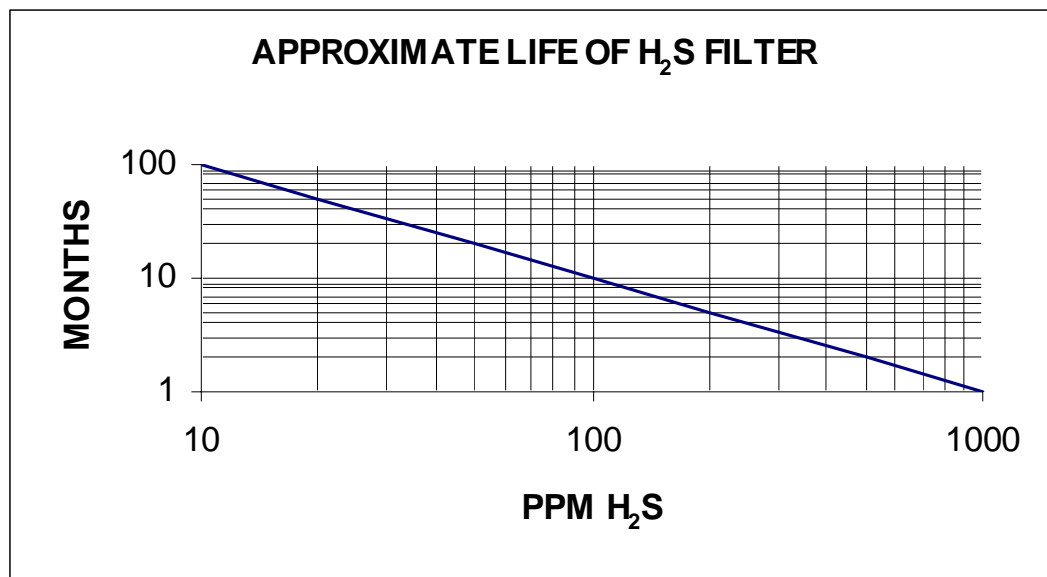
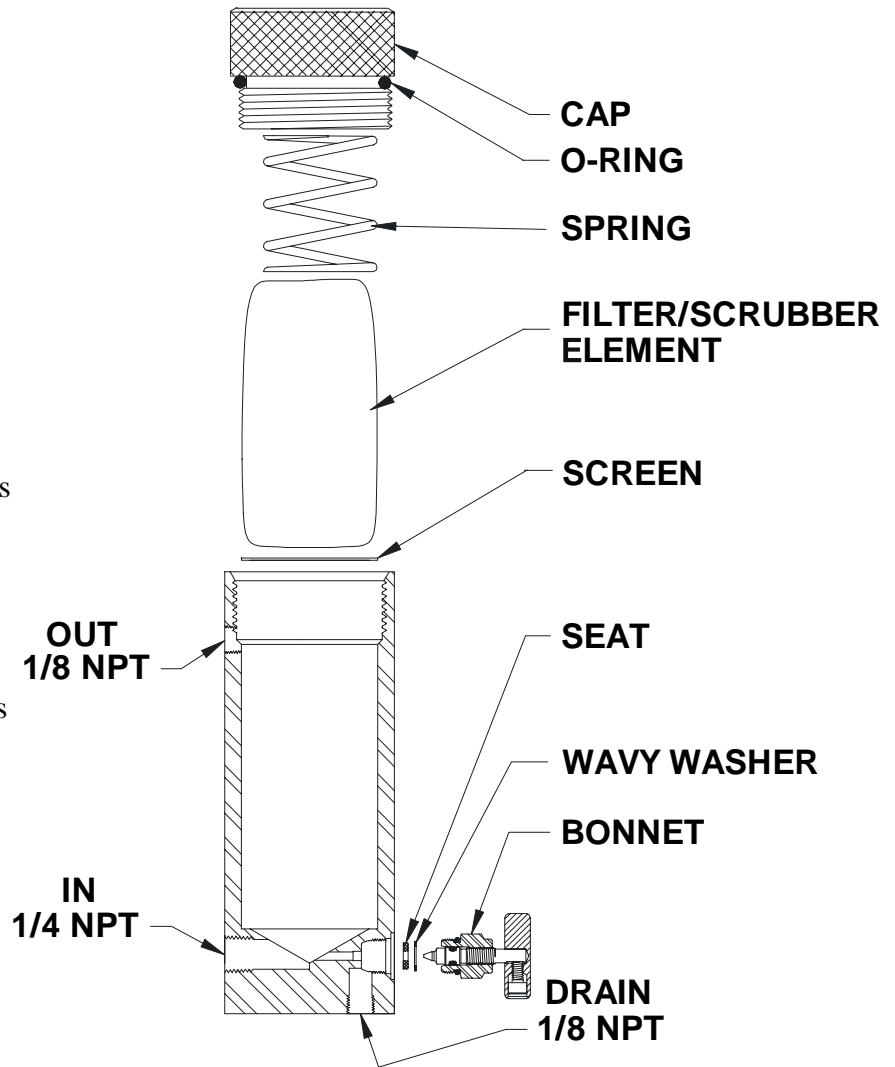

III. CFU (cont'd.)

Filter Replacement Instructions

Prior to servicing the Filter/Scrubber Canister, the sample line must be purged in the sequence listed below.

NOTE: Each of the valves referenced here are equipped with a right-hand thread. Turn clockwise to close and counter-clockwise to open.

- 1) Close the Top Cylinder Valve ①.
- 2) Close the Main Line Valve ②.
- 3) Open the Purge Valve ③.
- 4) Open Bleed Valve ④.

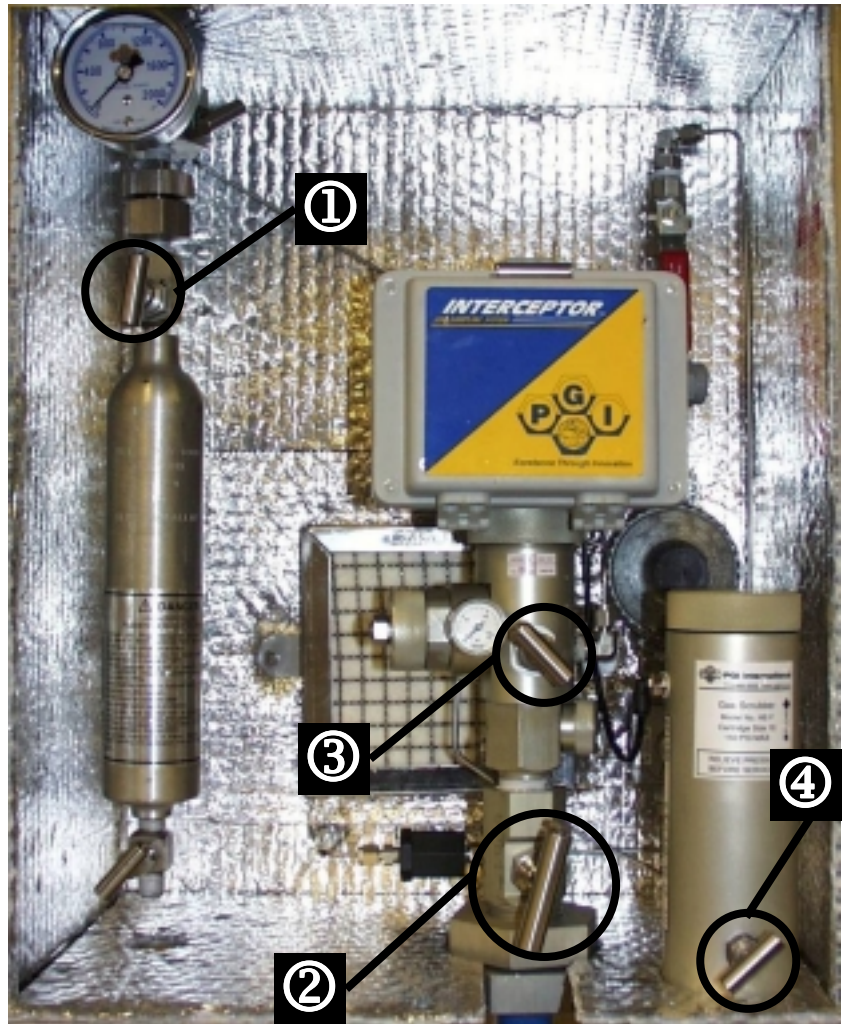

- 1) Remove the Cap and Spring from the Scrubber Canister.



- 2) Remove the existing Filter Bag (if any).

Note: Do not remove the Screen from the bottom of the Canister.

- 3) Look inside the Canister and make sure the Screen is lying flat.

Screen must lie flat.

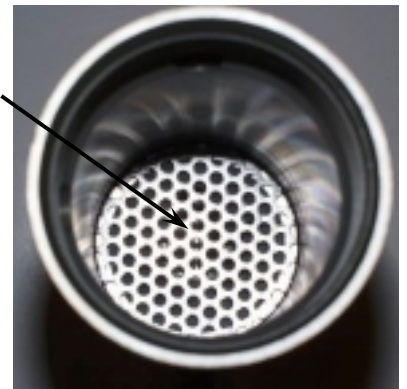

- 4) Open the Mylar® package and remove the new Filter Bag.



III. CFU (cont'd.)

- 5) Remove the last page from this manual and roll the new Filter Bag tightly as shown.



- 6) Pinch the Filter Bag through the paper and insert into the Canister. The paper should fit about halfway into the Canister, as shown below right.



- 7) Grab the paper at the top edge and, with an up and down motion, shake the Filter Bag out of the paper and into the Canister.



- 8) Pat the Filter Bag downward with your finger.

When properly installed, the Filter Bag should be below the cap threads, as shown.



Note: If the Filter Bag does not rest below the threads, remove it and repeat steps 5 through 8 until properly installed.

- 9) Place the Spring into the Canister, on top of the Filter Bag.



- 10) Install the Cap over the Spring and tighten hand-tight.



III. CFU (cont'd.)

After servicing the Filter/Scrubber Canister, pressure should be reintroduced to the sample line in the sequence listed below.

NOTE: Each of the valves referenced here are equipped with a right-hand thread. Turn clockwise to close and counter-clockwise to open.

- 1) Open the Main Valve ①.
(This will allow Sample Gas to escape from the bottom of the Canister.)
- 2) Close the Bleed Valve ②.
(The Pressure Gauge ③ will indicate line pressure.)
- 3) Open the Vent Valve ④ and allow to bleed for 5 seconds, then close.
- 4) Close the Purge Valve ⑤.
- 5) Open the Cylinder Valve ⑥

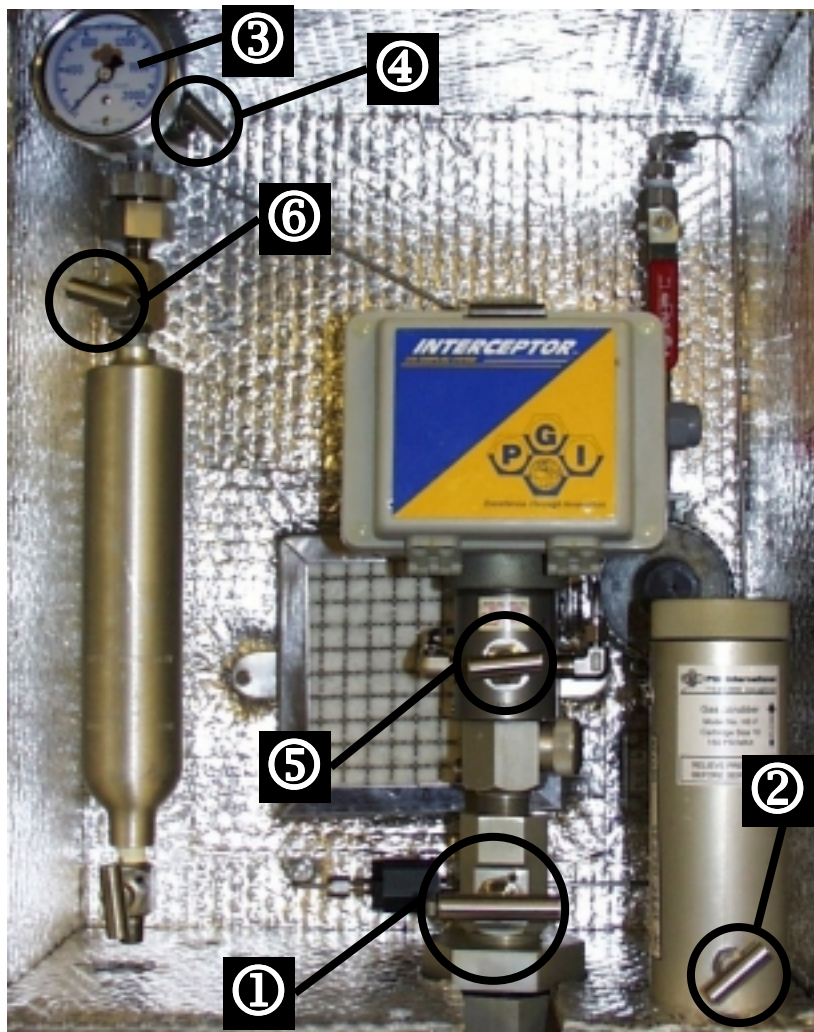

IV. Catalytic Heater

Specifications

Please read the CATA-DYNE™ HEATER Installation & Operation Instructions completely and thoroughly prior to operation.

WARNING!

The CATA-DYNE™ heaters used in PGI's Heated Enclosures are designed to use a natural gas fuel source. Prior to operation, refer to the CATA-DYNE™ Installation and Operation Instructions and verify that your fuel source is within 10% of the specified Btu/ft.³ rating. **A fuel source exceeding these limits may result in conditions that could ignite the fuel source, causing property damage and/or personal injury or death.** A fuel source below this range may result in difficulty in maintaining the catalytic reaction.

**If your fuel source is outside these parameters,
please contact PGI International for an Orifice Conversion Kit.**

(713) 466-0056 or (800) 231-0233

IV. Catalytic Heater (cont'd)

External Gas Source

PGI's PF1 Sample Pumps are designed for Sample Sites with low Line Pressures. If your operating pressure is 5 PSIG or less, you may have a problem keeping the heater lit because during the operation of the pump it can starve the heater for gas. It is recommended that you use an External Gas Supply either from another valve on the pipeline or another gas source. If your PF1 Heated Enclosure was ordered with the Low Pressure Option, the enclosure has been outfitted with a bulkhead connection on its right side for an External Gas Supply.

The External Gas Supply will enter the enclosure at the bulkhead and into the bottom-backside of the Scrubber Canister, which protects the Heater from contaminants. The Catalytic Heater Gas Supply can then be opened and closed using the Main Gas Supply Valve, as shown below.

- 1) Be sure the Main Gas Supply Valve is in the CLOSED position, prior to connecting the External Gas Supply.

Main Gas Supply Valve "CLOSED"



- 2) Connect the External Gas Supply to the Bulkhead .

Bulkhead

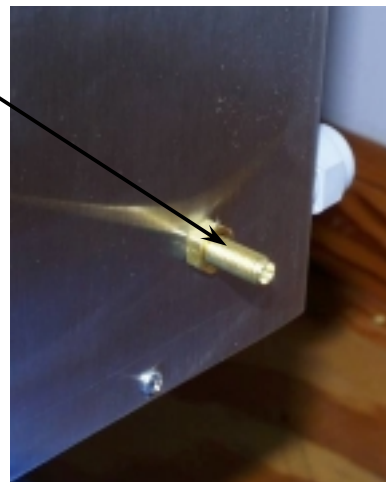

IV. Catalytic Heater (cont'd.)

Start-Up (Refer to Cata-Dyne Instructions provided.)

It is recommended to run conduit from the Catalytic Heater to a safe area usually 15 to 20 feet away from the pipeline. Run a pair of wire leads from the Catalytic Heater terminals to a terminal block outside the meter facility fence.

The leads must be of at least #10 gauge wire.

1. Remove heater housing cover from the back of the enclosure, then remove the electrical element cover.

Electrical Element Cover



2. Turn on the Main Gas Supply.

Main Gas Supply Valve "ON"



3. Connect jumper cables from your vehicle to the terminal block. **The cables should be connected to the terminal block first, then to the battery.** Polarity is not important.

Make sure the Heater Gas is turned on and the Canister is purged of all air.

Connect power to Electrical Elements

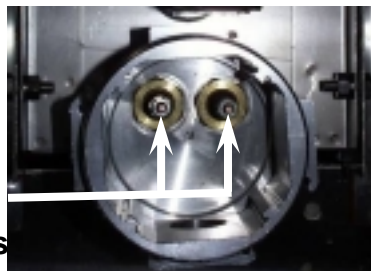

4. Allow the unit to warm up for a period of 15 minutes.
5. After the 15 minute warm up period, insert a screwdriver through the hole in the side of the heater housing and press and hold the reset button for 30 seconds. When the button is released, it should return to its original position. The internal valve should open and allow gas to the heater and create a catalytic reaction. If the valve does not open, allow an additional warm up period and press the button again.

NOTE: A dramatic rise in temperature will indicate that the catalytic reaction has been established.

Reset Button

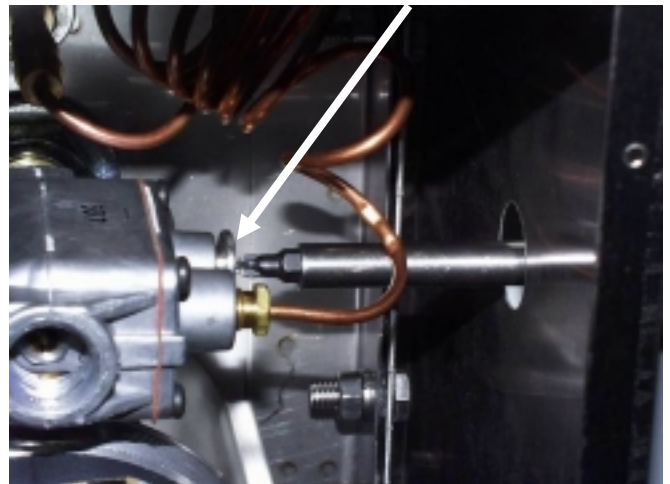

6. Once the catalytic reaction has been established, disconnect the power to the electrical elements.
7. To shut down the Catalytic Heater, turn off the Main Gas Supply Valve.

Main Gas Supply Valve "OFF"

