



Installation and Maintenance Manual for Cartridge Filter Unit CFU and CFU-C

PGI International, Ltd.
Excellence Through Innovation

WARNING! WARNING! WARNING! WARNING! WARNING! WARNING!

Do not perform any service on the unit unless
the area is known to be non-hazardous.

The optional CFU/CFU-C removes contaminants, moisture, and H₂S from the catalyst gas supply. The catalytic heater requires a clean, dry fuel source and using the filter/scrubber can extend the life of the catalyst. The CFU/CFU-C is outfitted with an AV106S-V-H8 bonnet assembly and a 1/8" NPT drain port to vent any liquids separated from the gas supply.

The gas supply from the regulator pump enters the CFU/CFU-C through the 1/4" NPT port on the backside, bottom portion of the scrubber canister. As the gas travels upward through the filter, contaminants are trapped and liquids are dropped to the bottom. The filtered gas is allowed to continue upward to the 1/8" NPT outlet port on the backside, top portion of the canister.

Note: DO NOT REMOVE THE PLUG FROM THE 1/8" NPT ON THE SIDE OF THE CANISTER.

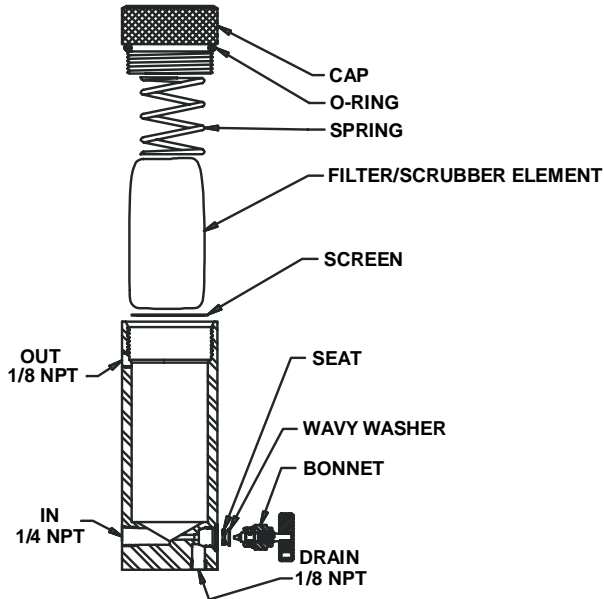

16101 Vallen Drive—Houston, Texas 77041
(713) 466-0056 or (800) 231-0233
www.pgaint.com

Assembly

- 1) Remove the cap from the top of the scrubber canister.
- 2) Reach inside the canister and remove the spring.

Note: Do not remove the screen from the bottom of the canister.

- 3) Open the Mylar[®] package and remove the filter bag.
- 4) Look inside the canister and make sure the screen is lying flat.

Screen must lie flat.



-
- 5) Place the filter bag into the canister, on top of the screen.

Note: If the bag appears to be too large to fit into the canister, poke the bag downward around the edges with your fingertip.

DO NOT PUNCTURE THE BAG.



-
- 6) Place the spring on top of the filter bag.



- 7) Place the Cap onto the Canister and tighten hand-tight.

The filter/scrubber is now ready for installation.

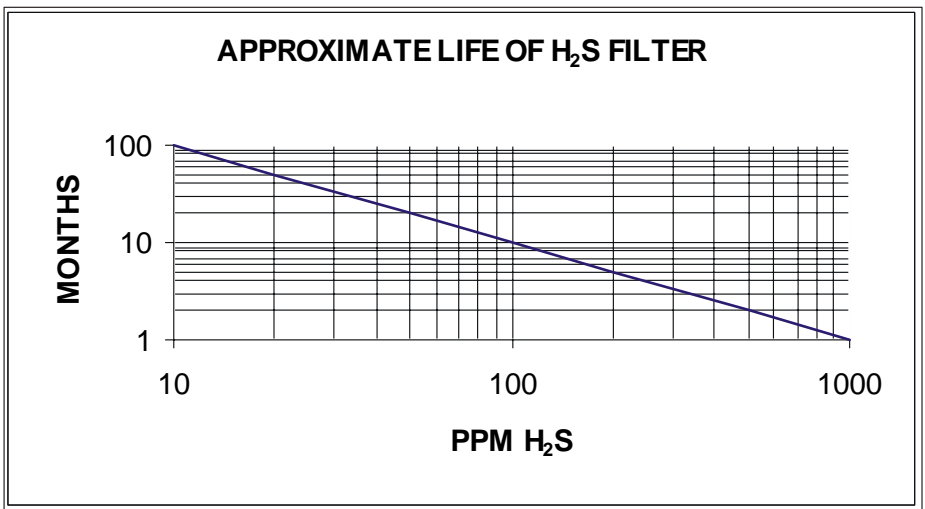

Installation

IMPORTANT!

The CFU/CFU-C must be installed vertically, with the cap on top to allow moisture to collect in the bottom. Relieve pressure before servicing.

Your filter/scrubber includes a stainless steel Mounting Bracket as standard equipment.

For a 2" CARBON STEEL U-Bolt Assembly for pipe mounting, use the "-P1" option code.

To get the U-Bolt Assembly in STAINLESS STEEL, use the "-P2" option code.

