

### General Description

Series 500CS low pressure carbon steel ball valves provide total shut-off capability for services up to 138 Bar (2000 PSI).

### Operation

A quarter turn of the handle is on or off. Ball valves are not intended for use as a throttling valve. Attempting to use it in these applications may result in premature seal failure and/or inability to turn the valve handle.

### Features

- Ball valve bodies are machined from high quality carbon steel and phosphate coated forgings providing superior corrosion resistance.
- Highly inert PTFE seats and seals provide resistance to chemical corrosion.
- Blowout proof stem design, chrome plated brass ball and a special design handle enable increased turn and leverage for ease of opening and closing.
- Padlocking handle options provides lock-out capability where required.
- In-line or panel mount options provide installation flexibility.

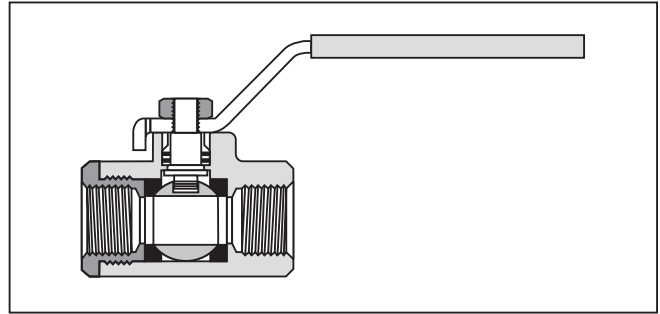
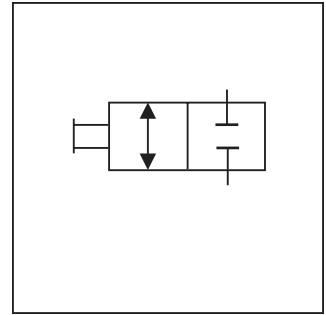

### Specifications

<b>Maximum Working Pressure</b>	Sizes 1/4" - 1" 138 Bar (2000 PSI)
	Sizes 1 1/4" - 2" 103 Bar (1500 PSI)
	Saturated Steam up to 10 Bar (150 PSI) and 177C (350°F)
<b>Body Material</b>	Carbon Steel, Phosphate Coated

### Performance Curves

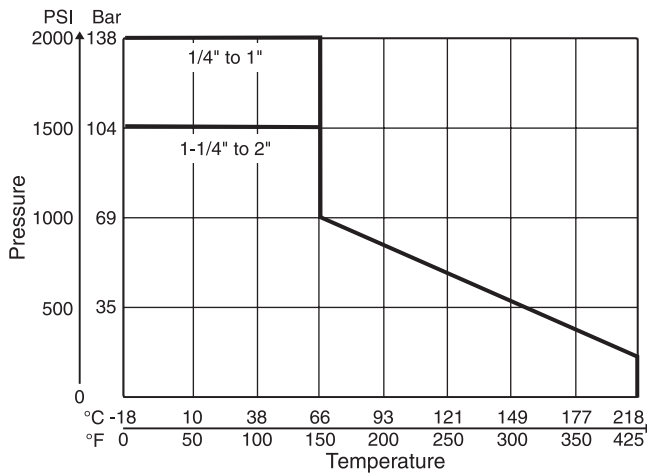

### Flow Data

Type 500CS, 502CS	
Valve Size	C <sub>v</sub>
1/4"	6.0
3/8"	12.0
1/2"	15.0
3/4"	23.0
1"	36.0
1-1/4"	44.0
1-1/2"	64.0
2"	114.0

**WARNING:** This product can expose you to chemicals including Lead, Nickel (Metallic), or 1,3-Butadiene which are known to the State of California to cause cancer, and Lead or 1,3-Butadiene which is known to the State of California to cause birth defects and other reproductive harm. For more information go to [www.P65Warnings.ca.gov](http://www.P65Warnings.ca.gov).

Cat3300\_02.indd, ddp, 04/19

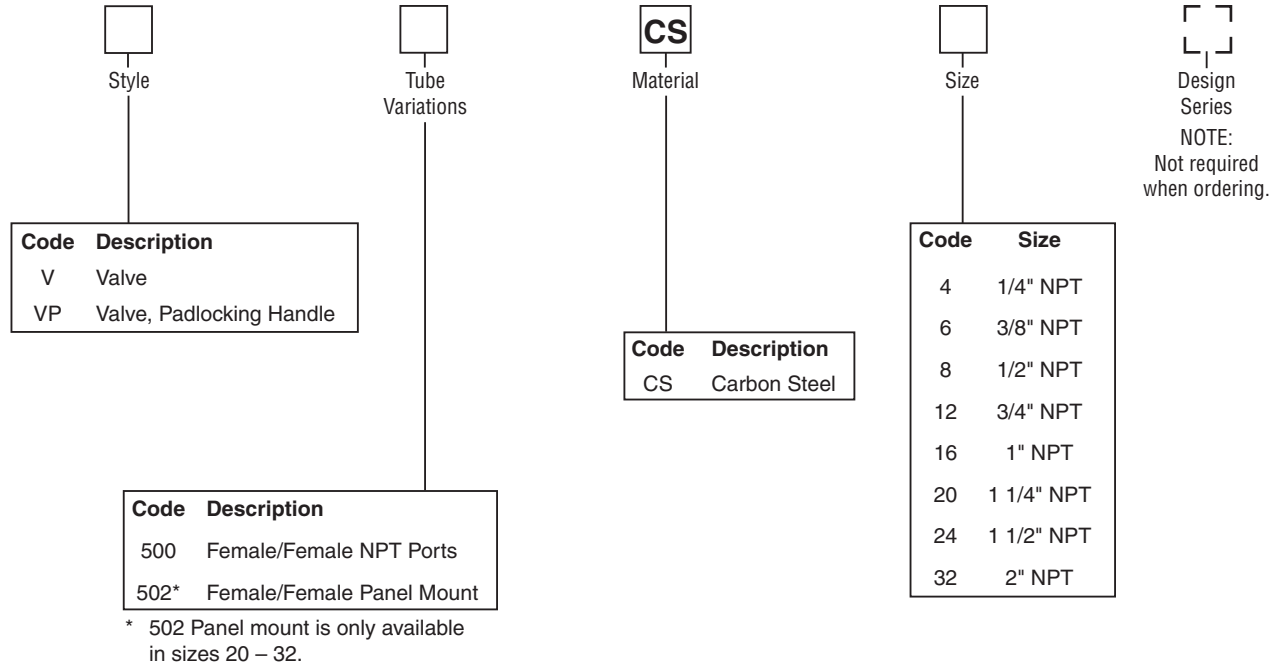

**Model V500CS and VP500CS**

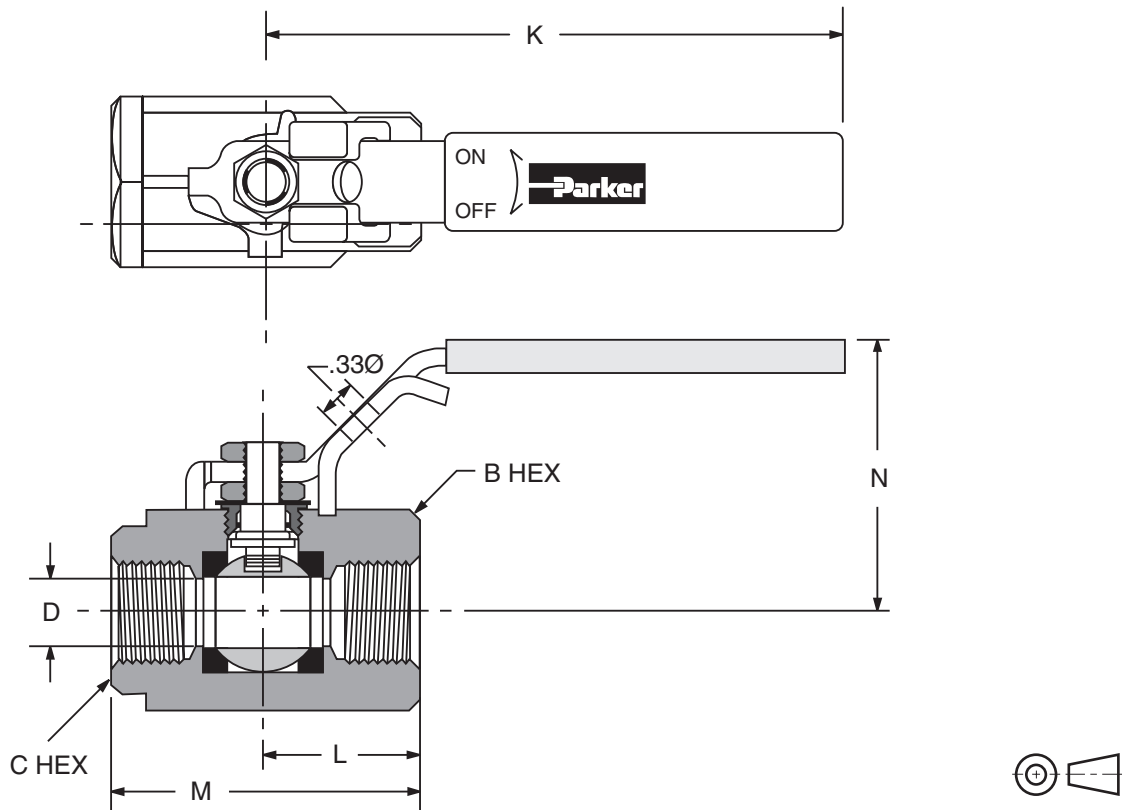

Part Number	Pipe Thread	B Hex	C Hex	Dimensions mm (in)				D Flow Ø
				K	L	M	N	
<b>Female-Female Pipe Ends V500CS</b>								
V500CS4	1/4"	1-1/16"	15/16"	96.0 (3.78)	25.4 (1.00)	50.8 (2.00)	41.4 (1.63)	10.2 (0.400)
V500CS6	3/8"	1-1/16"	15/16"	96.0 (3.78)	25.4 (1.00)	50.8 (2.00)	41.4 (1.63)	10.2 (0.400)
V500CS8	1/2"	1-1/4"	1-1/16"	96.0 (3.78)	31.8 (1.25)	60.2 (2.37)	43.9 (1.73)	13.7 (0.540)
V500CS12	3/4"	1-5/8"	1-3/8"	129.5 (5.10)	38.1 (1.50)	73.7 (2.90)	52.8 (2.08)	17.3 (0.680)
V500CS16	1"	2"	1-5/8"	129.5 (5.10)	44.7 (1.76)	86.6 (3.41)	58.4 (2.30)	22.4 (0.880)
<b>Locking Handle, Female Pipe Ends VP500CS (Shown above)</b>								
VP500CS4	1/4"	1-1/16"	15/16"	104.9 (4.13)	25.4 (1.00)	50.8 (2.00)	56.6 (2.23)	10.2 (0.400)
VP500CS6	3/8"	1-1/16"	15/16"	104.9 (4.13)	25.4 (1.00)	50.8 (2.00)	56.6 (2.23)	10.2 (0.400)
VP500CS8	1/2"	1-1/4"	1-1/16"	104.9 (4.13)	31.8 (1.25)	60.2 (2.37)	56.6 (2.23)	13.7 (0.540)
VP500CS12	3/4"	1-5/8"	1-3/8"	127.0 (5.00)	38.1 (1.50)	73.7 (2.90)	71.1 (2.80)	17.3 (0.680)
VP500CS16	1"	2"	1-5/8"	127.0 (5.00)	44.7 (1.76)	86.6 (3.41)	75.4 (2.97)	22.4 (0.880)

**Model V502CS and VP502CS**

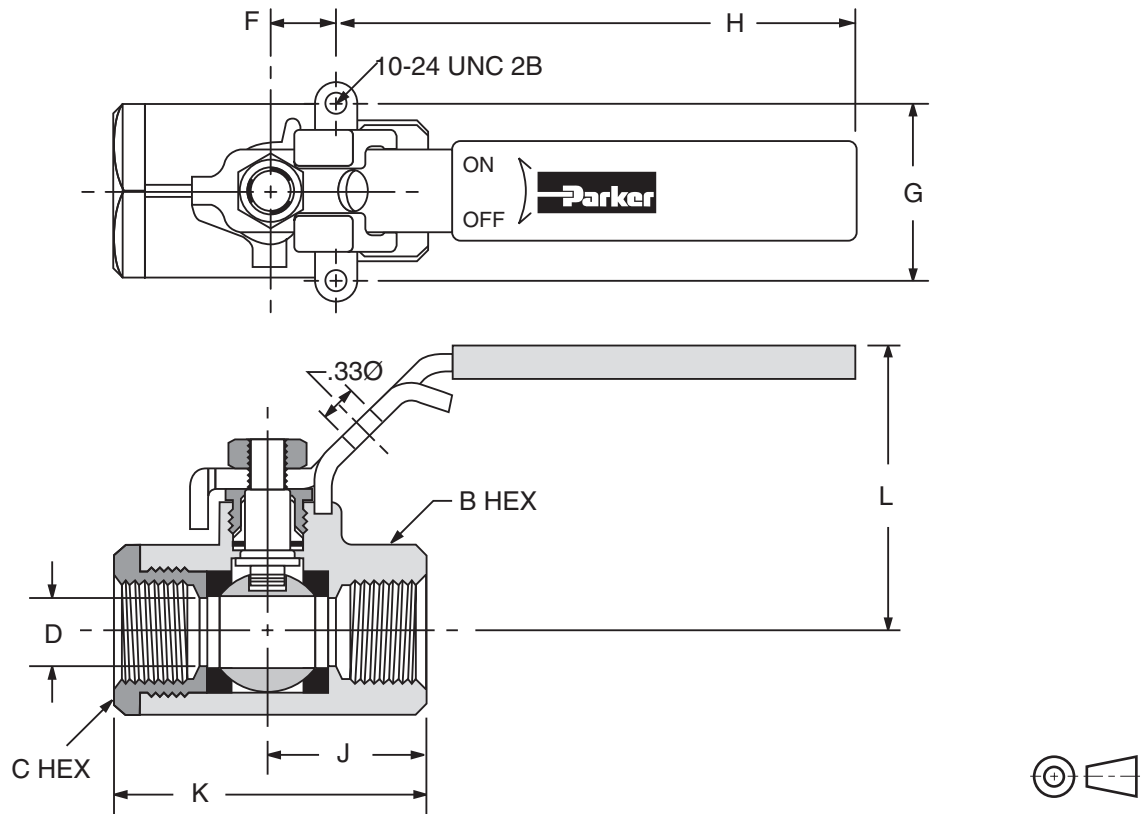

Part Number	Pipe Thread	B Hex	C Hex	Dimensions mm (in)						D Flow Ø
				F	G	H	J	K	L	
<b>Female-Female Pipe Ends, Panel Mount V502CS</b>										
V502CS20	1-1/4"	2"	2-1/4"	23.9 (0.94)	38.1 (1.50)	154.9 (6.10)	47.5 (1.87)	96.5 (3.80)	70.1 (2.76)	25.4 (1.000)
V502CS24	1-1/2"	2-5/16"	2-1/2"	23.9 (0.94)	38.1 (1.50)	154.9 (6.10)	57.7 (2.27)	115.6 (4.55)	75.7 (2.98)	31.8 (1.250)
V502CS32	2"	2-3/4"	3"	26.2 (1.03)	50.8 (2.00)	218.4 (8.60)	61.5 (2.42)	122.7 (4.83)	89.9 (3.54)	38.1 (1.500)
<b>Locking Handle, Female Pipe Ends, Panel Mount VP502CS (Shown above)</b>										
VP502CS20	1-1/4"	2"	2-1/4"	23.9 (0.94)	38.1 (1.50)	190.5 (7.50)	47.5 (1.87)	96.5 (3.80)	80.0 (3.15)	25.4 (1.000)
VP502CS24	1-1/2"	2-5/16"	2-1/2"	23.9 (0.94)	38.1 (1.50)	190.5 (7.50)	57.7 (2.27)	115.6 (4.55)	85.6 (3.37)	31.8 (1.250)
VP502CS32	2"	2-3/4"	3"	26.2 (1.03)	50.8 (2.00)	222.3 (8.75)	61.5 (2.42)	122.7 (4.83)	87.9 (3.46)	38.1 (1.500)