

GVM Global Vehicle Motor Power Series

Permanent Magnet (PMAC) Motor
for Mobile Systems



ENGINEERING YOUR SUCCESS.



WARNING - USER RESPONSIBILITY

FAILURE OR IMPROPER SELECTION OR IMPROPER USE OF THE PRODUCTS AND/OR SYSTEMS DESCRIBED HEREIN OR RELATED ITEMS CAN CAUSE DEATH, PERSONAL INJURY AND PROPERTY DAMAGE.

- This document and other information from Parker Hannifin Corporation, its subsidiaries and authorized distributors provide product and/or system options for further investigation by users having technical expertise.
- The user, through its own analysis and testing, is solely responsible for making the final selection of the system and components and assuring that all performance, endurance, maintenance, safety, and warning requirements of the application are met. The user must analyze all aspects of the application, follow applicable industry standards, and follow the information concerning the product in the current product catalog and in any other materials provided from Parker or its subsidiaries or authorized distributors.
- To the extent that Parker or its subsidiaries or authorized distributors provide component or system options based on data or specifications provided by the user, the user is responsible for determining that such data and specifications are suitable and sufficient for all applications and reasonably foreseeable uses of the components or systems.
- The products described herein, including without limitation, product features, specifications, designs, availability and pricing, are subject to change by Parker Hannifin Corporation and its subsidiaries at any time without notice.

General Description.....	4
RELIABILITY & DURABILITY.....	5
EFFICIENCY.....	6
POWER DENSITY.....	7
Performance	8
Typical Efficiency.....	8
Technical Characteristics.....	9
Global Vehicle Inverter (GVI)	10
Inverter association.....	10
GVM210.....	11
Dimensions.....	11
GVM310.....	15
Dimensions.....	15
Options and Accessories.....	19
Order Code.....	22

General Description



High power Permanent Magnet AC motors (PMAC) offer the best solution to meet the requirements of vehicle duty performance. With a ten year legacy and thousands of units sold in the GVM series, the high power density and speed capabilities of Parker GVM Power Series motors combined with a matched inverter provide the speed and torque required to achieve breakthrough performance in a variety of vehicle platforms.

The GVM Power Series motor is a powerful choice for both on and off-road vehicles, engineered for traction and electro-hydraulic pumps (EHP) up to 409 kW peak power. The GVM provides very high efficiency, up to 2% higher versus comparable PMAC designs, enabling energy savings of up to 30% compared to induction technologies.

In addition to operating as a high-power motor, the GVM is a very high efficiency generator. A variety of available magnetic options allow for a wide range of voltage, speed, and torque requirements. The GVM family achieves high power density thanks to a patented liquid cooling system, which also results in a cleaner, less complex design.

The GVM is an example of how Parker is providing the building blocks for vehicle electrification, developing turnkey technologies that cut time to market while reducing supply chain complexity.

Applications:

- **Traction**
- **Generators**
- **Electro-hydraulic pumps**

Markets:

- **Construction**
- **Mining**
- **Material Handling**
- **Trucks**
- **Bus**
- **Agriculture**
- **Military**

And other off-highway vehicle, autonomous vehicle, and E-Mobility markets

Overview:

- Rated power up to 228 kW (continuous)
- High power density
- Peak torque up to 1430 Nm
- Rotational speed up to 8000 rpm¹
- Low inertia / high dynamic
- Low and high voltage options 24 VDC to 800 VDC
- Scalable torque with multiple magnetic lengths
- Multiple shaft options available

¹ For higher speeds, please review your application with our applications team.

RELIABILITY & DURABILITY

To ensure reliability and long life under tough conditions, the GVM motors have been put through a battery of validation tests. These tests, designed to simulate the worst conditions a vehicle would be subjected to, cover mechanical, environmental, and electrical categories. The lists below include highlights of the testing. Please contact Parker regarding specific or custom validation standards.



- Long lifetime
- Reduced downtime
- Less maintenance
- Subjected to rigorous environmental testing
- High ingress protection level available
- Ceramic bearings

"[We've] tested a lot of motors in the GVM class and the Parker GVM was clearly the best of the lot"
Engineer, scientific research facility

Testing and Validation Details:

Mechanical

- Random and swept sine vibration testing to simulate worst case fatigue exposure to SAE J1455
- Shock and vibration levels exceeding SAE J1455 for unsprung mass applications.

Environmental

- Dust and sand, and gravel bombardment to SAE J1455
- Salt Spray - Fog and Immersion to SAE J1455

Electrical

- HiPot insulation test to IEC 34-1 at $2 \times V_{RMS} + 1000 V_{RMS}$
- Insulation resistance to ISO 6469-3
- EMC emission and immunity to IEC 34-1 (motor only)

DURABILITY/RELIABILITY

are characteristics of the GVM that make it suitable for rough environments.

THAT'S 5400 TIMES
AROUND THE WORLD!



QUICK FACT:

Over 135 million road miles have been logged by Parker GVM motors since 2012.



Test standards meet
SAE J1455
for Dust, Sand, Gravel
Bombardment,
Humidity, Salt Spray
and Immersion,
Operating Temps
from -40° to 120°C,
Crash Shock,
and Vibration

EFFICIENCY

Lowering energy consumption, making the most of a battery charge, and reducing the amount of waste heat produced are design goals of any electric or hybrid vehicle project. The high efficiency of the GVM series make it a stand-out in the field of mobile duty motors.



- **Lower energy consumption for compliance with emerging energy legislations and green initiatives**
- **Up to 2% more efficient than comparable PMAC designs**
- **Operates efficiently as motor or generator for maximum energy recovery during braking and deceleration**
- **Reduced vehicle emissions for smaller CO₂ footprint**
- **Reduced battery size**
- **Extended vehicle range**
- **Lower cost of ownership over life of vehicle**
- **Reduced thermal losses allow for smaller, less expensive vehicle cooling system**
- **On electro-hydraulic systems, efficiency gains are made by allowing the use of a constant displacement pump versus variable, increasing pump efficiency**

The battery is one of the most expensive and largest components in a vehicle system, and a high efficiency motor can help optimize both battery lifetime and time between charges. This translates to more time in service and more revenue for the fleet owner.

"We've tested four different competitive products and the Parker GVM is the most efficient, and we are recommending this motor ..."
Design engineer, OEM truck manufacturer

"The GVM technology provides more value than the competition. This includes better continuous torques without oil cooling and improved efficiency at peak power."
Engineering manager, OEM bus company

EFFICIENCY

is the motor's capability to produce useful mechanical power efficiently. A more efficient motor reduces the cost to operate, runs cooler, and is better for the environment.

UP TO
2% MORE EFFICIENT THAN COMPETITIVE MOTORS

GVM applications have reduced emissions by over 20,000 tons of CO₂

Parker's higher efficiency GVM means a **cost reduction of the vehicle battery** or **longer range** between charges.



POWER DENSITY

Limited mounting space and the need to pack a lot of power into close quarters requires a motor design with high power density, which is defined by the amount of power (time rate of energy transfer) per unit volume. The GVM is designed to meet these criteria, providing value to the vehicle manufacturer.



- **Reduced space claim**
- **Less weight for better performance**
- **Lighter motor can provide larger payload capacity**
- **Helps vehicle designers meet packaging and performance goals**
- **Patented cooling helps achieve vehicle performance objectives**
- **Enhanced productivity in the form of higher vehicle capacity**

"The GVM space claim and power density allowed Parker to win the business and allow our customers to realize fuel savings. These motors have proven to be very reliable for nearly 135 million cumulative miles driven period"

Hybrid vehicle system company co-founder

Cooling System

- Enables high power density
- Cooling liquid: Water/Glycol 50%¹
- Circular stator comprising the cooling system can be inserted as a kit in any circular housing (Parker or customer)
- Eliminates the cooling jacket required in other motor technologies, saving weight and space
- Low pressure drop reduces power required to circulate coolant

¹ For oil cooled applications, please consult factory

POWER DENSITY

refers to the amount of power produced relative to the physical size of the motor.

**FROM
40%
TO
100%
MORE PEAK POWER
THAN COMPETITIVE MOTORS**

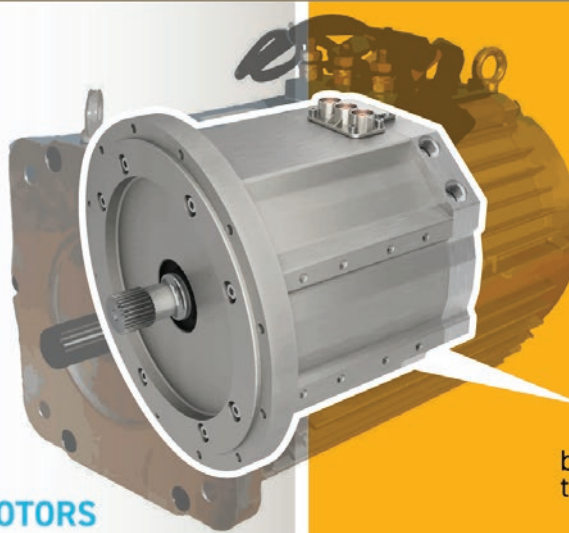

The high power density of the GVM saves on installation cost when compared to oil cooled motors.

**Reduced
space claim -
Up to
66%
better power density
than competitive motors**

Performance

GVM Power Series motors are designed to meet the power requirements in a wide variety of vehicle applications. The GVM has the ability to operate at different battery voltages without loss of power.

- Up to 800 VDC
- Numerous rotor lengths
- Multiple winding configurations per length

By selecting the appropriate voltage, rotor length and winding variation, the following parameters can be refined to match the vehicle's specific performance requirements:

- Peak torque
- Peak power
- Rated torque
- Rated speed
- Rated power
- Maximum speed

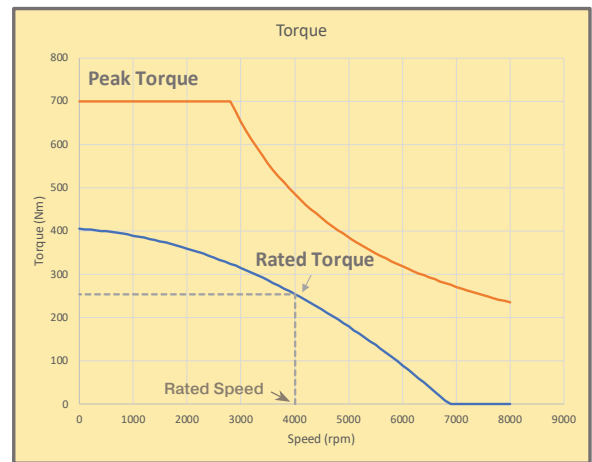
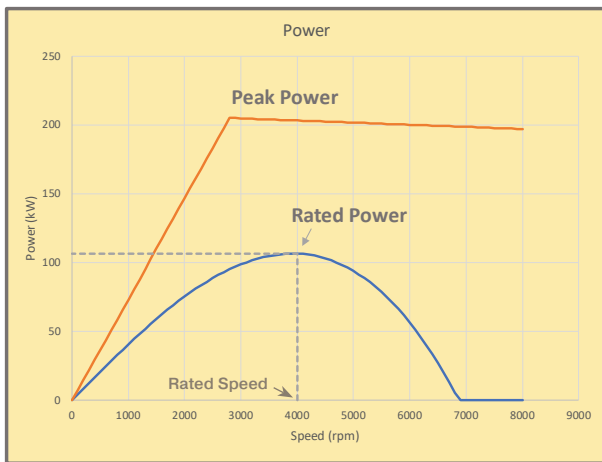

Efficiency

Only when using the best component technology and optimal design characteristics do traction motors/generators and controllers minimize losses both during motoring and power generation (four quadrant mode) increasing vehicle range. Variable speed system allows higher efficiency even at low speed.

Typical Efficiency Maps - Battery Voltage 650 VDC

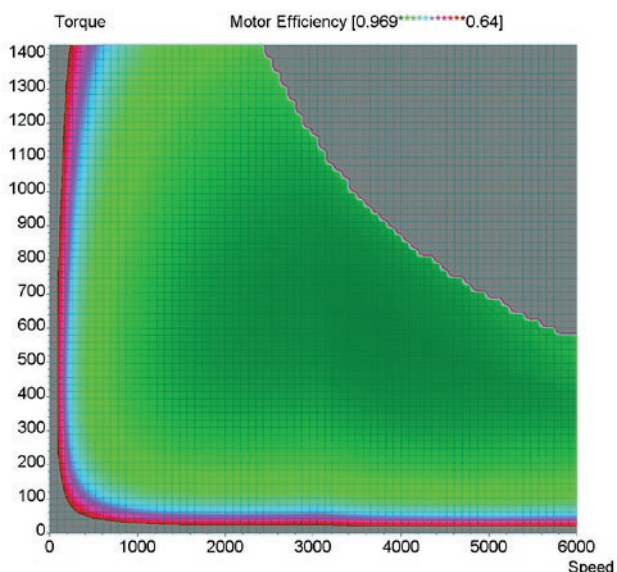

GVM310-250-BA-2 in motor operation mode

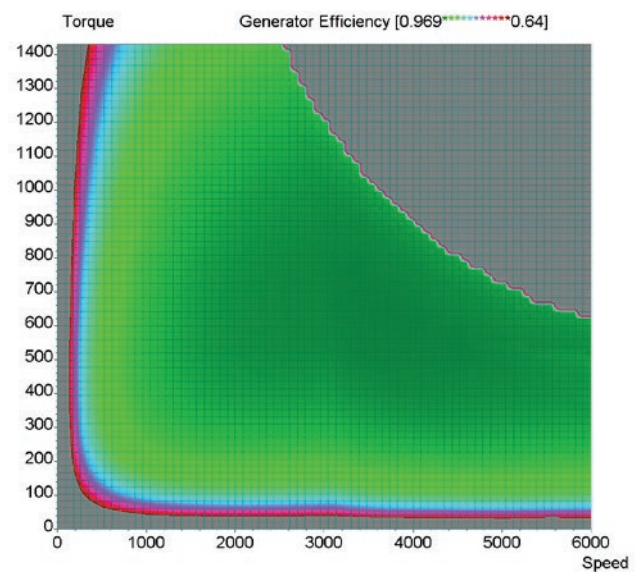

GVM310-250-BA-2 in generator operation mode

Technical Characteristics

GVM210 Motor Model Number	Battery Voltage	Rated Torque Mn	Rated Power Pn	Rated Current In	Rated Speed Nn	Peak Torque Mp	Peak Power Pp	Peak Current Ip	Max Speed Nmax*	Ke
	[VDC]	[Nm]	[kW]	[Arms]	[rpm]	[Nm]	[kW]	[Arms]	[rpm]	[Vrms/Krpm]
GVM210-050-P-GF1-W	350	30	12	34	4000	82	16	77	8000	83,3
GVM210-050-P-EH1-W		32	18	48	5400	82	24	110	8000	58,5
GVM210-050-P-JH1-W	650	32	17	25	5200	82	23	58	7600	111
GVM210-100-P-EH1-W	350	64	20	55	3000	172	23	111	7000	121
GVM210-100-P-GF1-W	650	58	26	38	4400	172	32	78	4900	172
GVM210-100-P-EH1-W		64	37	53	5600	172	46	111	7000	121
GVM210-150-P-DD1-W	350	76	28	78	3600	261	33	153	6300	134
GVM210-150-P-GF1-W	650	92	27	40	2800	261	31	78	3200	262
GVM210-150-P-CB1-W		105	77	108	7000	261	98	233	8000	87,9
GVM210-200-P-AM1-W	350	143	108	286	7200	351	177	781	8000	35,2
GVM210-200-P-EH1-W	650	114	39	57	3300	351	45	112	3400	247
GVM210-200-P-BG1-W		133	108	150	7800	351	149	352	8000	78,1
GVM210-300-P-AK1-W	350	209	131	340	6000	530	194	857	8000	48,5
GVM210-300-P-AR1-W	650	201	160	223	7600	530	264	620	8000	67
GVM210-400-P-AK1-W	350	272	131	340	4600	709	193	857	8000	64,9
GVM210-400-P-AK1-W	650	237	194	269	7800	709	364	857	8000	64,9

GVM310 Motor Model Number	Battery Voltage	Rated Torque Mn	Rated Power Pn	Rated Current In	Rated Speed Nn	Peak Torque Mp	Peak Power Pp	Peak Current Ip	Max Speed Nmax*	Ke
	[VDC]	[Nm]	[kW]	[Arms]	[rpm]	[Nm]	[kW]	[Arms]	[rpm]	[Vrms/Krpm]
GVM310-125-P-BG2-W	350	302	92	241	2910	700	147	685	8000	96
GVM310-125-P-BA1-W		222	100	266	4280	610	165	902	8000	64
GVM310-125-P-MW1-W		198	114	300	5500	610	185	1015	8000	58
GVM310-125-P-CE2-W	650	292	104	145	3390	700	170	424	5500	154
GVM310-125-P-BT2-W		256	108	151	4040	700	205	514	6600	128
GVM310-125-P-NP1-W		204	117	166	5500	610	192	559	8000	106
GVM310-200-P-MP1-W	350	315	165	437	5010	990	241	1323	8000	73
GVM310-200-P-MW2-W		442	124	325	2670	1140	216	984	8000	105
GVM310-200-P-MP2-W		419	145	378	3310	1140	281	1287	8000	81
GVM310-200-P-BG2-W	650	463	161	225	3310	1140	280	694	5500	153
GVM310-200-P-NH1-W		308	159	225	4930	990	229	678	6300	134
GVM310-200-P-NC1-W		334	178	253	5090	990	283	828	7300	116
GVM310-250-P-BA1-W	350	542	138	370	2420	1240	166	906	6400	132
GVM310-250-P-MW1-W		404	147	390	3480	1240	185	987	7100	119
GVM310-250-P-MP1-W		432	179	475	3960	1240	241	1320	8000	90
GVM310-250-P-MW1-W	650	434	228	323	5010	1240	350	1022	7100	119
GVM310-250-P-NC2-W		537	177	246	3150	1430	331	814	5200	162
GVM310-250-P-MW2-W		479	199	278	3960	1430	409	1001	6400	132

*The maximum operating speed depends on maximum BEMF accepted by the drive (values given for a Peak Voltage of 1200V)

Max. mechanical speed is 8 000 rpm.

Values in table represent GVM ratings with input cooling liquid at **65°C** (Characteristics are given for an optimal drive/motor association without any limitation coming from the drive). For alternative cooling temperatures please contact us.

Global Vehicle Inverter (GVI)

With functional safety at its very core, the second generation GVI mobile inverter provides a single-family solution for both traction and work function applications, on and off-road. All three sizes are rated up to IP6K9K and are designed for ISO26262 and EN13849 functional safety standards. Plug and socket connections on the front face simplify installation, and the comprehensive configuration software tool combined with both CANopen and J1939-76 support give system design flexibility.



	Low voltage	High Voltage
Nominal Voltage	24 / 48 / 80 / 96 Vdc	650 Vdc
Peak Current	700 Arms	500 Arms
Peak Power	68 kVA	300 kVA
Safety	-	Motor Torque Off and HVIL
Protection	IP65	IP6K9K
Control Type	Speed or Torque control	
Feedback	Sin/Cos encoder	Resolver
Communication	CAN J1939, CANopen, Parker IQAN compatible	
Cooling	Cold plate	WEG liquid cooled
Conformance	IEC60068, EN61000-4, EN1175-1, IEC60529, EN55022	ISO20653:2006, ISO16750-4, ISO16750-3 EN60068-2, CISPR25 Ed.4 Class 3, ISO11452-4, ISO11452-8, ISO7637-2

Inverter association

Motor Model Number	Inverter	Battery Voltage	Rated Torque Mn	Rated Power Pn	Rated Speed Nn	Peak Torque Mp	Peak Power Pp	Max Speed Nmax
		[VDC]	[Nm]	[kW]	[rpm]	[Nm]	[kW]	[rpm]
GVM210-050-P-AJ1-W	GVI C024 0550	24	30,17	6,667	2480	57,22	11,79	3200
GVM210-050-P-AR1-W	GVI D048 0450	48	37,21	11,37	3630	68,67	17,24	4400
GVM210-050-P-BT1-W	GVI D096 0350	96	45,38	11,76	3900	82,5	15,07	5990
GVM210-100-P-AK1-W	GVI D048 0450	48	56,74	11,52	2175	108,6	21,71	3000
GVM210-100-P-AK1-W	GVI D096 0400	96	69,03	20,96	3500	129,3	35,8	4000
GVM210-100-P-AR1-W	GVI G650 0300	350	102,4	46,03	5850	172	58,5	5990
GVM210-100-P-BT1-W	GVI E096 0500	96	95,36	26,37	3000	180,4	48,2	4000
GVM210-150-P-AK1-W	GVI G650 0300	350	161,8	48,88	5250	261,5	58,07	5990
GVM210-150-P-BT1-W	GVI G650 0300	350	161,8	48,88	5250	261,5	58,07	5990
GVM210-150-P-BM1-W	GVI G650 0300	650	155,7	83,99	5990	261,5	129,1	5990
GVM210-200-P-BT1-W	GVI G650 0300	350	219,2	50,14	3900	351	57,5	5990
GVM210-200-P-BE1-W	GVI G650 0300	350	219	70,7	4650	306,8	84,64	5990
GVM210-200-P-BT1-W	GVI G650 0300	650	217,5	87,19	5100	351	110,3	5990
GVM210-300-P-BM1-W	GVI G650 0300	350	331,4	57,95	3000	530	66,52	5990
GVM210-300-P-AK1-W	GVI G650 0300	350	174,3	86,92	5400	230,2	116	5990
GVM210-300-P-BT1-W	GVI G650 0300	650	332,4	90,25	3300	530	109,2	5990
GVM210-300-P-BE1-W	GVI G650 0300	650	328,7	127,4	5250	462,8	159,7	5990
GVM210-400-P-AY1-W	GVI G650 0300	350	396,1	85,77	3150	512,7	104,4	5990
GVM210-400-P-BM1-W	GVI G650 0300	650	439,6	106,3	3600	709	127,3	5990
GVM210-400-P-AT1-W	GVI G650 0300	650	357,1	161,2	5250	464,1	206,2	5990

GVM210

Dimensions

Power connector option 6 - Terminal Box

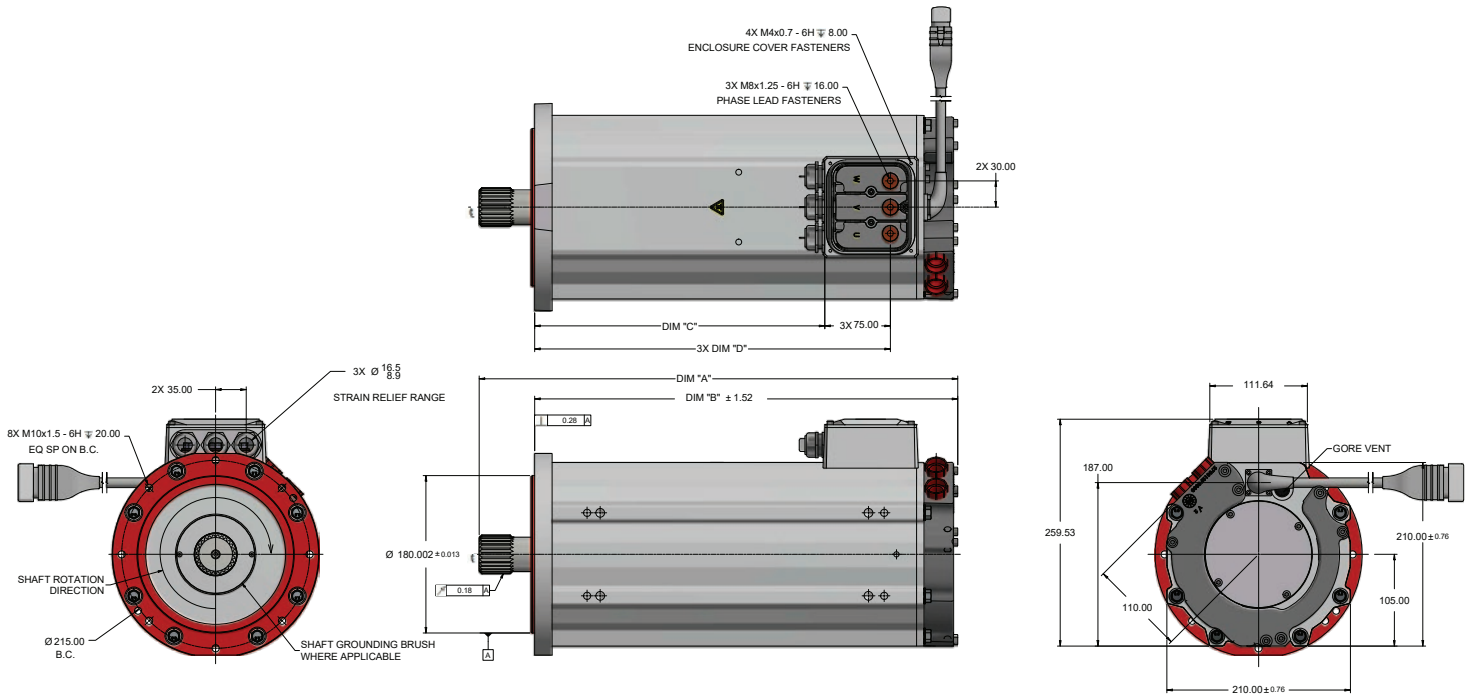

Splines Option	TA				TB			
	A	B	C	D	A	B	C	D
GVM210-050	273.53	234.13	82	157	na	na	na	na
GVM210-100	323.53	284.13	132	207	na	na	na	na
GVM210-150	na	na	na	na	397.63	334.13	182	257
GVM210-200	na	na	na	na	447.63	384.13	232	307
GVM210-300	na	na	na	na	547.63	547.63	332	407
GVM210-400	na	na	na	na	647.63	584.13	432	507

All dimensions in mm.

Dimensions

Power connector option 3 - 1 x HV PowerLok™ 300A

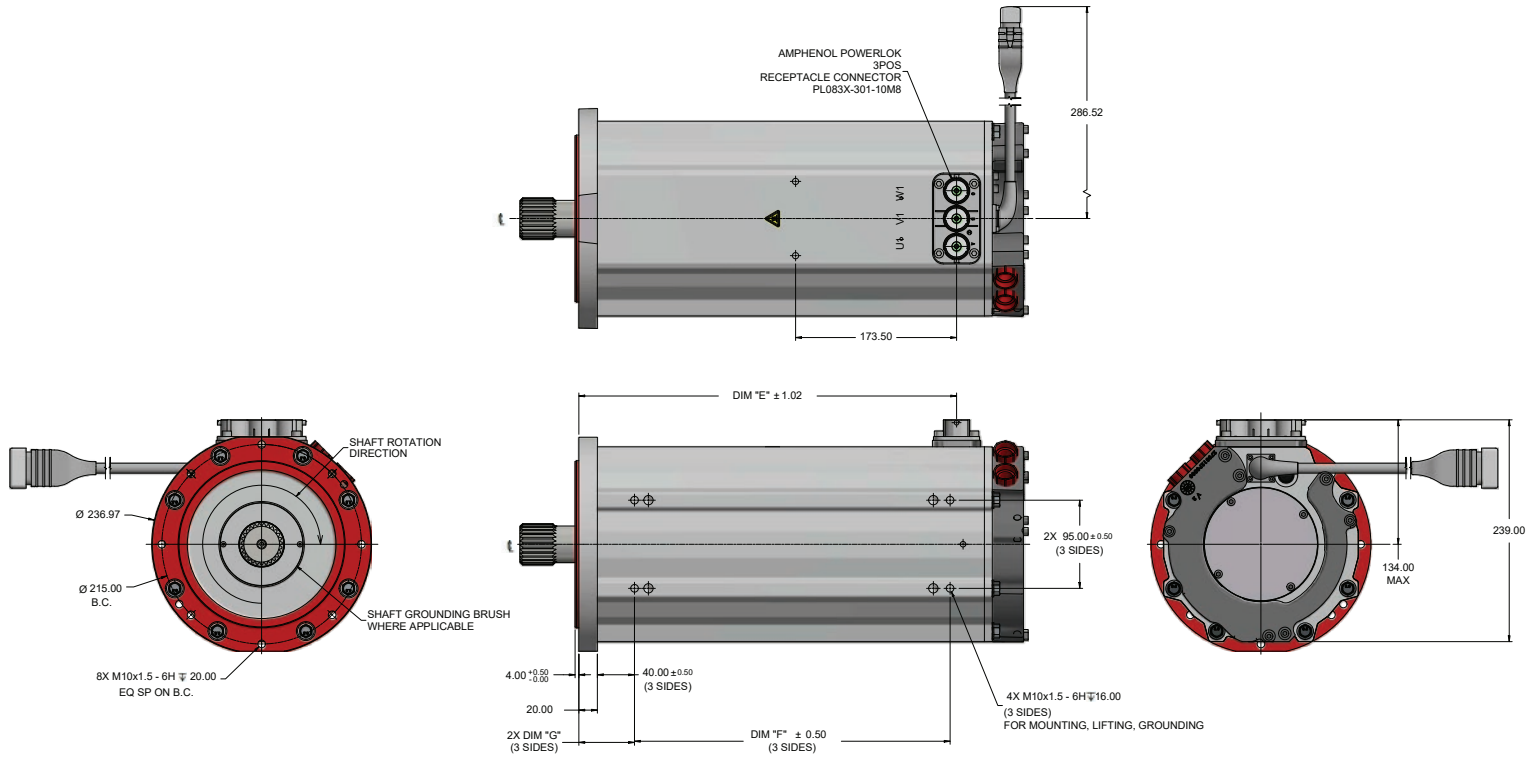

Fec Type	TRACTION		
	E	F	G
GVM210-050	157	90	60
GVM210-100	207	140	
GVM210-150	257	190	
GVM210-200	307	240	
GVM210-300	407	340	
GVM210-400	507	440	

All dimensions in mm.

Dimensions

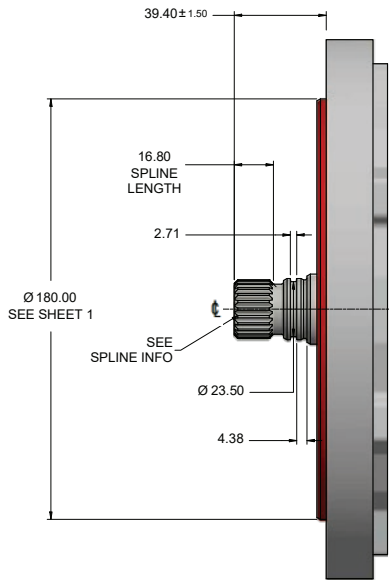

'TA' SPLINE

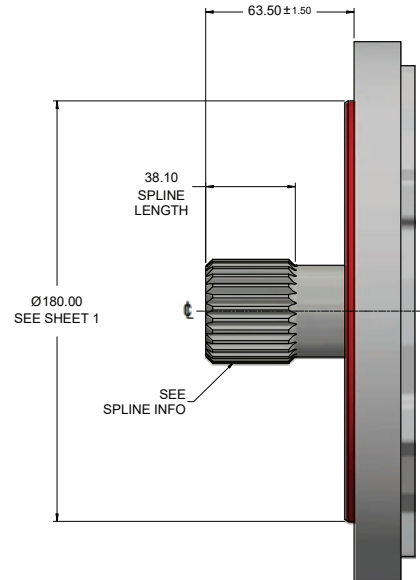

'TB' SPLINE

Spline Interface Data

	TA	TB
GVM210 Motor Frame Size	050 - 100	150 - 400
Involute Spline	ANSI B92.2M	ANSI B92.1
Side fit	Flat Root Class 6h	Fillet Root Class 5
Number of teeth	24	27
Module	1.0000	N/A
Spline Pitch	N/A	16/32
Pressure angle	30.0°	30.0°
Pitch diameter (Ref)	24.000	42.863
Base diameter (Ref)	20.785	37.12
Major diameter (Ref)	25.00/24.75	44.45/44.32
Minor diameter (Max)	22.5/22.26	39.27
Form diameter (Max)	22.89	41.17
Circular tooth thickness (Max effective)	1.571	2.456
Circular tooth thickness (Min actual)	1.485	2.421
Pin diameter	2.120	3.048
Measurement over pins (Ref)	27.479/27.399	47.459/47.406

All dimensions in mm.

Consult factory for wet spline option

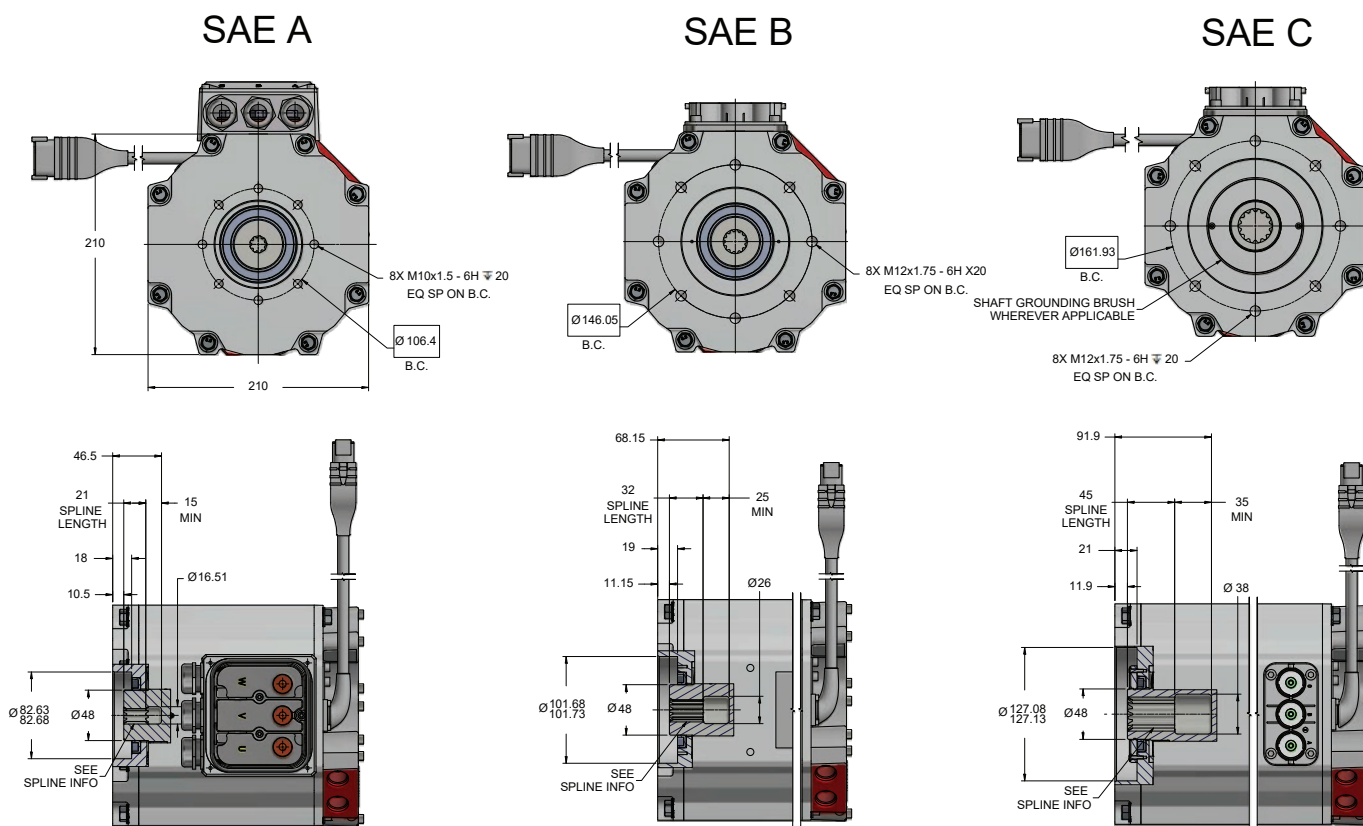

SAE Interface Data

MODIFIED FROM ANSI B92.1 - 1972 CLASS 5			
SAE type	SAE A	SAE B	SAE C
GVM210 Motor Frame Size	050	050 - 150	200 - 400
Number of teeth	9	13	14
Pitch	16/32	16/32	12/24
Pressure angle	30°	30°	30°
Base diameter (Ref)	12.372	17.871	25.664
Pitch diameter (Ref)	14.287	20.637	29.634
Major diameter (Min/Max)	16.484/16.586	22.606/22.86	32.334/32.588
Form diameter (Min)	15.976	22.326	31.851
Minor diameter (Min/Max)	12.928/13.055	19.151/19.278	27.686/28.067
Circular space width max actual	2.567		3.398
Circular space width min effective	2.494		3.324
Circular space width min actual	2.532		3.362
Measurement between pins (max)	10.010/10.109	16.527/16.603	24.33/24.406
Pin diameter	2.743		3.657

All dimensions in mm.

Note: Terminal box and Amphenol Powerlok options are available for all motors sizes.

GVM310

Dimensions

GVM310 / SAE Pump Mount Style

Power connector option 3 - 1 x HV PowerLok™ 300A

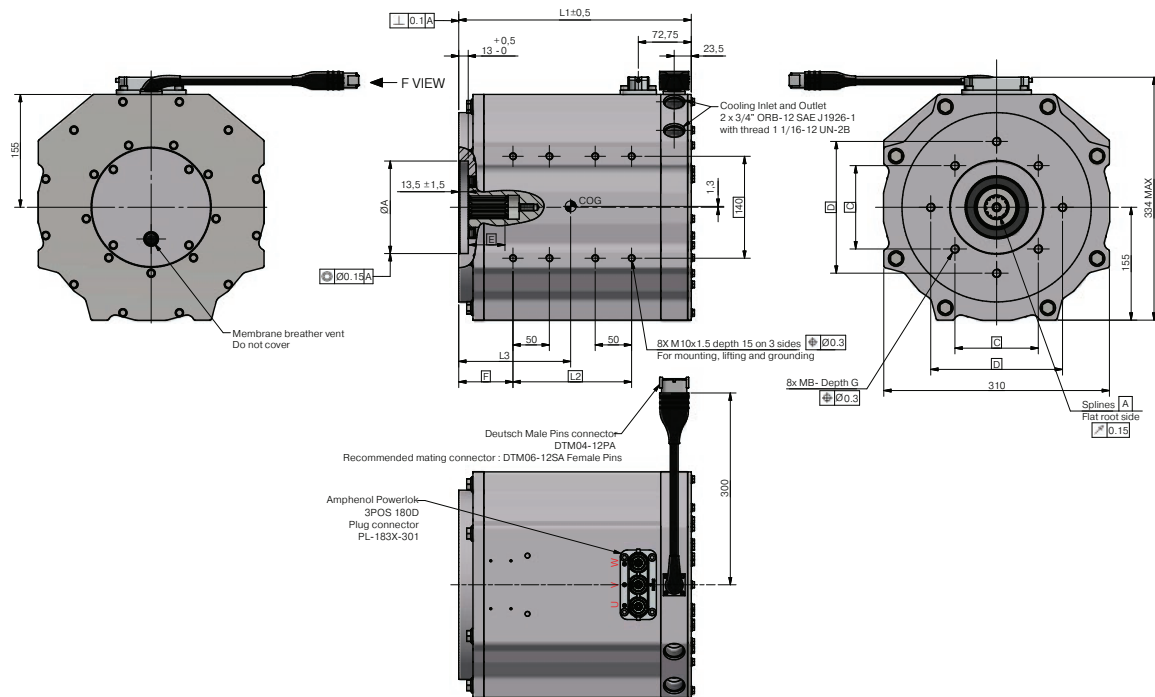

Motor Data

Motor size	L1	L2	L3	SAE C	SAE D	Weight
GVM310-125	320	163	154	X	na	97
GVM310-200	395	238	191	X	na	132
GVM310-200	402	238	197	na	X	132
GVM310-250	452	288	222	na	X	157

SAE Interface Data

SAE Type	A	B	C	D	E	F
SAE C	127.15G7	12	114.5	181	50	74.5
SAE D	152.55G7	16	161.6	228.6	65	81.5

Spline Interface Data

Consult factory for wet spline option

ANSI B92.1	SAE C	SAE D
Flat root side fit	Class 5	Class 6
Number of teeth	14	13
Spline Pitch	12/24	8/16
Pressure angle	30°	30°
Base diameter (Ref)	25.663	35.745
Pitch diameter (Ref)	29.63	41.275
Major diameter (Max)	32.588	45.669
Form diameter (Max)	31.852	44.452
Minor diameter (Min)	27.610	38.252
Circular space width (Max actual)	3.426	5.095
Circular space width (Min effective)	3.325	4.986

All dimensions in mm.

GVM310 / SAE Pump Mount Style

Power connector option 4 - 3 x HV PowerLok™ 500A

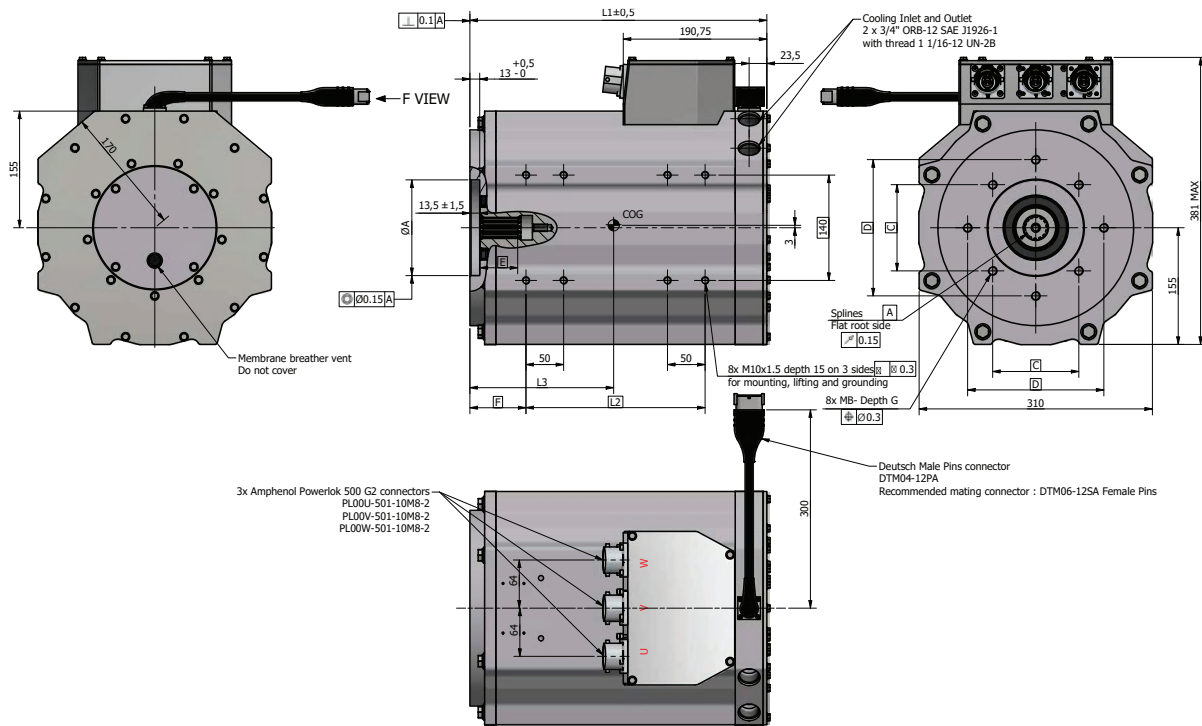

Motor Data

Motor size	L1	L2	L3	SAE C	SAE D	Weight
GVM310-125	320	163]	154	X	na	97
GVM310-200	395	238	191	X	na	132
GVM310-200	402	238	197	na	X	132
GVM310-250	452	288	222	na	X	157

SAE Interface Data

SAE Type	A	B	C	D	E	F
SAE C	127.15 G7	12	114.5	181	50	74.5
SAE D	152.55 G7	16	161.6	228.6	65	81.5

Spline Interface Data

Consult factory for wet spline option

ANSI B92.1	SAE C	SAE D
Flat root side fit	Class 5	Class 6
Number of teeth	14	13
Spline Pitch	12/24	8/16
Pressure angle	30°	30°
Base diameter (Ref)	25.663	35.745
Pitch diameter (Ref)	29.63	41.275
Major diameter (Max)	32.588	45.669
Form diameter (Max)	31.852	44.452
Minor diameter (Min)	27.610	38.252
Circular space width (Max actual)	3.426	5.095
Circular space width (Min effective)	3.325	4.986

All dimensions in mm.

GVM310 / Traction Mount (SAE 4)

Power connector option 4 - 3 x HV PowerLok™ 500A

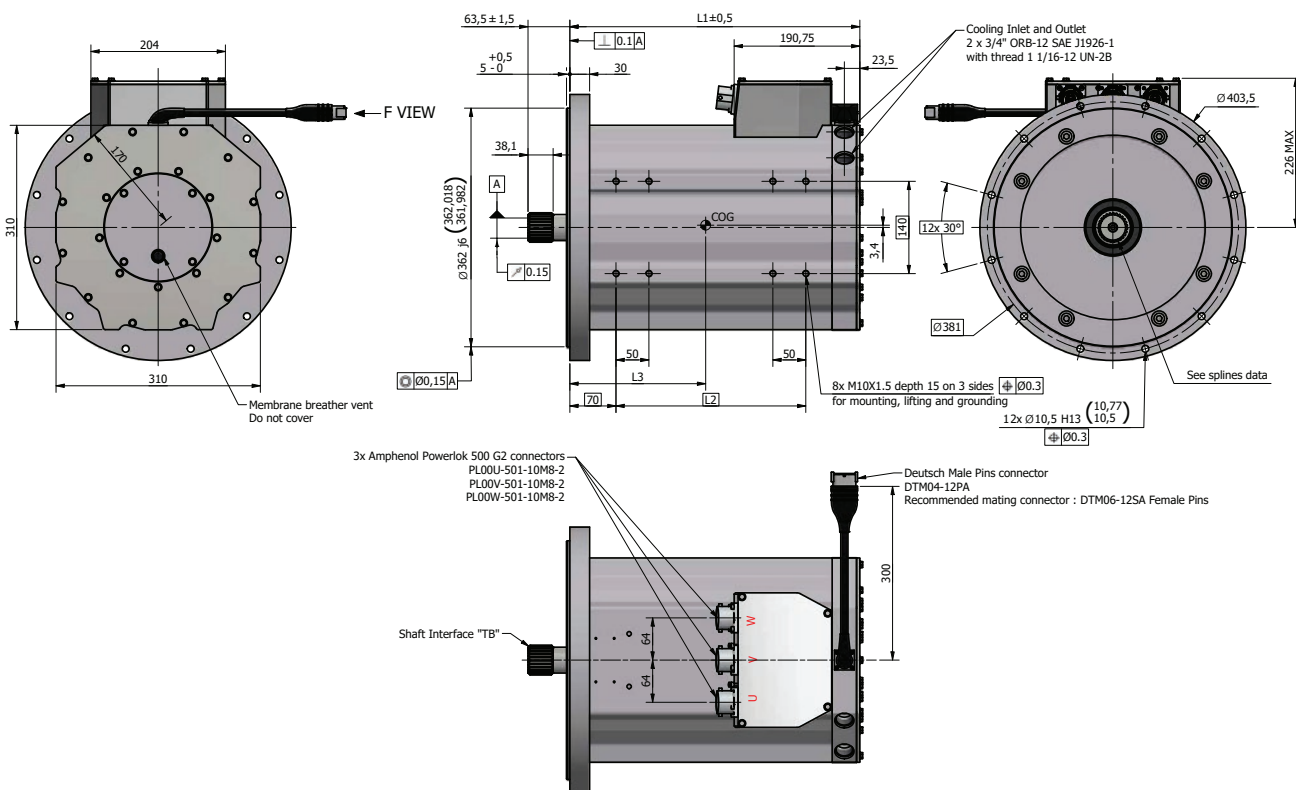

Motor Data

Motor size	L1	L2	L3	Shaft Interface	Weight
GVM310-200	390	238	281	TB	135
GVM310-250	440	288	206	TB	158

Spline Interface Data

ANSI B92.1	Involute
Side fit	Flat Root Class 5
Number of teeth	27
Spline Pitch	16/32
Pressure angle	30°
Base diameter (Ref)	37.12
Pitch diameter (Ref)	42.863
Major diameter	44.45/44.32
Form diameter (Max)	41.17
Minor diameter	40.36
Circular tooth thickness (Max effective)	2.456
Circular tooth thickness (Min actual)	2.421
Pin diameter	3.048
Measurement over pins (Ref)	47.460/47.407

All dimensions in mm.

Consult factory for wet spline option

GVK Kit Motor

High level of customisation - Only for high volume OEM applications

Frameless kit motors can be the ideal solution for high volume machine designs that require high performance in small spaces. Lightweighting is an important design concept used by automotive engineers that is especially important to employ in heavy on-highway and off-highway hybrid and electric vehicle to increase range, performance, productivity and reliability.

By integrating Parker's active magnetics, and patented cooling into your mechanics you can eliminate mechanical, electrical, and cooling interfaces that reduce space claim, reduce parts, and failure modes. Kit motors also allow for direct integration with a mechanical transmission device, eliminating parts that add size and complexity.

If you have an application in mind, our engineering team will be happy to discuss the particulars of a frameless design option.

- **Flexibility of design by using a kit version to integrate the motor into a global system**
- **Available as a potted circular stator including the cooling system**
- **Provides a customized and integrated mechanical design**
- **GVK range has the same electrical characteristics as GVM range**

Consider a kit motor for:

- Integration into axles
- Integration into transmission
- Truck
- Bus
- Construction
- Mining

Configured ePump

Configured ePumps are designed and optimized for hybrid electric and all electric mobile applications.

Configured ePumps consist of a GVM motor, directly coupled to an hydraulic pump and controlled by a high performance mobile hardened GVI inverter.

Parker's configured ePumps provide the lowest possible installed cost and highest efficiency while still maintaining superior reliability in the most demanding applications.

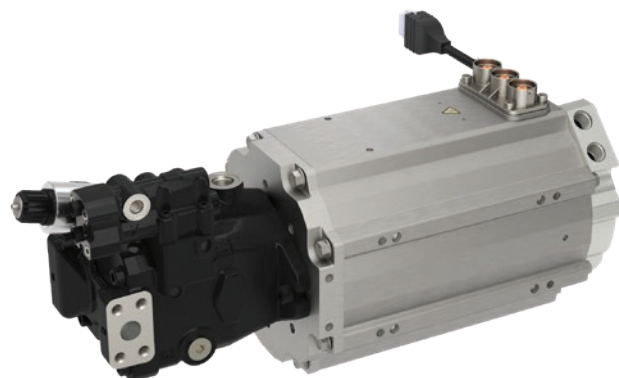

Thermal Management

The QDC cooler range, whether 24 VDC or 600 VDC ties in perfectly with Parker inverters and motors ensuring greatest efficiency for all electrified applications.

- 20-30% more efficient cooling matrix
- Low noise fan and fan housing
- High performance fan drive with integrated inverter
- Fan speed control from 1200 RPM to 4750 RPM
- Air free fluid
- 50-60% less space and power consumption
- Silent operation
- Compact design - low space claim



GVM Hoses

We recommend to use the Parker Multipurpose Transfer Hose - Oilpress N/L 20-30 :



Part Number	I.D. (mm)	O.D. (mm)	Max. Working Pressure			Weight kg/m	min. Bend Radius mm	in Stock
			MPa	psi	bar			
OILPRESS N/L 20								
IH30832000/40	6	12	2.0	300.0	20	0.12	25	Y
IH30832001/40	8	14	2.0	300.0	20	0.15	35	Y
IH30832002/40	10	17	2.0	300.0	20	0.21	40	Y
IH30832003/40	13	20	2.0	300.0	20	0.26	55	Y
IH30832004/40	16	23	2.0	300.0	20	0.31	65	Y
IH30832005/40	19	28	2.0	300.0	20	0.47	80	Y
IH30832006/40	25	36	2.0	300.0	20	0.74	100	Y

GVM Fittings

To complete your installation some additional components like hose fittings, connectors, and hoses may be required. While we do not provide these items, your local Parker hose distributor can assist. Find one on www.parker.com or call (800) C-Parker.

Coolant Connections

GVM210 : Coolant inlet / outlet are ORB-8 SAE J1926-1 with thread 3/4-16 UNF

GVM310 : Coolant inlet / outlet are ORB-12 SAE J1926-1 with thread 1-1/16-12 UNF

We advise to use the male stud, fittings and hose as follow :

For EO 24° cone end (DIN 3861 / ISO 8434-1) :

GVM Fittings			
Motor	P/N Fitting	T1	T
GVM210	GE15L3/4UNFOMDCF	3/4-16 UNF-2A	M22x1,5
GVM310	GE18L11/16UNOMDCF	1" 1/16-12 UN-2A	M26x1,5

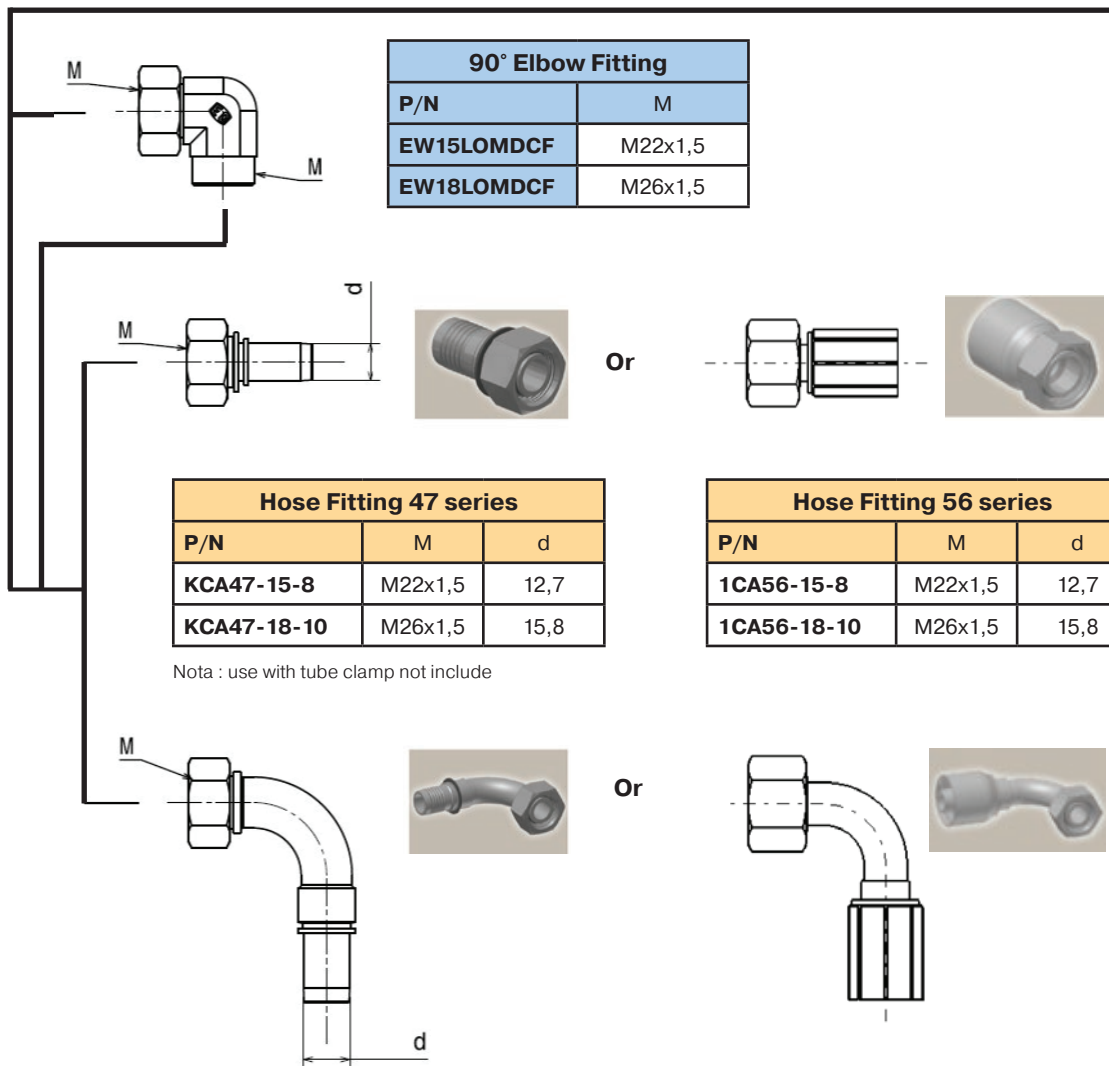
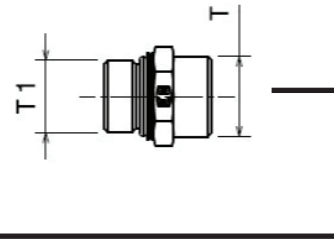

90° Elbow Fitting	
P/N	M
EW15LOMDCF	M22x1,5
EW18LOMDCF	M26x1,5



Or

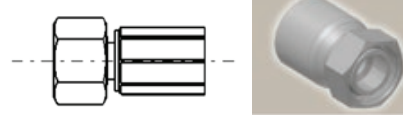

Hose Fitting 47 series		
P/N	M	d
KCA47-15-8	M22x1,5	12,7
KCA47-18-10	M26x1,5	15,8

Hose Fitting 56 series		
P/N	M	d
1CA56-15-8	M22x1,5	12,7
1CA56-18-10	M26x1,5	15,8

Nota : use with tube clamp not include



Or

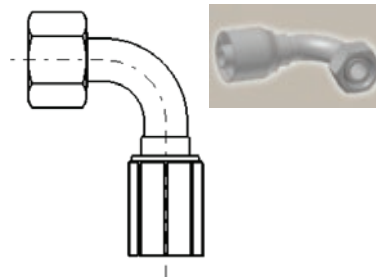

90° Elbow Hose Fitting 47 series		
P/N	M	d
KCF47-15-8	M22x1,5	12,7
KCF47-18-10	M26x1,5	15,8

90° Elbow Hose Fitting 56 series		
P/N	M	d
1CF56-15-8	M22x1,5	12,7
1CF56-18-10	M26x1,5	15,8

Nota : use with tube clamp not include

Order Code

	1	2	3	4	5	6	7	8	9	10	11
Order example	GVM	310	200	P	BA1	W	R	A	3	1	PD

1 Motor series

GVM	Global Vehicle Motor
GVK ¹	Global Vehicle Kit Motor

2 Frame size (outer width)

210	210 mm
310	310 mm

3 Stack length

	GVM210	GVM310
050	x	
100	x	
125		x
150	x	
200	x	x
250		x
300	x	
400	x	

4 Type of Motor Series

P	Power Series
----------	--------------

5 Magnetics option

....	See motor tables
------	------------------

6 Cooling system

W	Liquid cooling (please contact us for flow & cooling temperature data)
----------	--

7 Feedback

R	Brushless resolver
S	Sincos encoder

8 Thermal switch

A	PT1000 and PTC (GVM310 only)
B	PT1000 (GVM210 only)

9 Power Termination

3	1 x HV PowerLok™ 300A PL083X-301
4 ²	3 x HV PowerLok™ 500A PL00X-500
5 ^{1,2}	2 x HV PowerLok™ 300A PL083X-301
6	Terminal Box

10 Feedback Termination

1	12 male pin pigtail Deutsch DTM04-12PA
----------	--

11 Output Shaft

		GVM210	GVM310
PA	SAE A	page 10-13	
PB	SAE B	page 10-13	
PC	SAE C	page 10-13	page 15, 17
PD	SAE D		page 15, 17
TA	Traction	page 10-13	
TB	Traction	page 10-13	page 16, 18
WA ¹	Wet spline SAE A		
WB ¹	Wet spline SAE B		
WC ¹	Wet spline SAE C		
WD ¹	Wet spline SAE D		

¹ Please consult us
² GVM310 only



www.parker.com



European Headquarters
La Tuilière 6, 1163 Etoy,
Switzerland
Tel: +41 21 821 85 00

Your authorized Distributor