



## GVM142 Global Vehicle Motor

Permanent Magnet (PMAC) Motors and Generators for Vehicle Applications



ENGINEERING YOUR SUCCESS.



**WARNING – USER RESPONSIBILITY**

**FAILURE OR IMPROPER SELECTION OR IMPROPER USE OF THE PRODUCTS DESCRIBED HEREIN OR RELATED ITEMS CAN CAUSE DEATH, PERSONAL INJURY AND PROPERTY DAMAGE.**

- This document and other information from Parker-Hannifin Corporation, its subsidiaries and authorized distributors provide product or system options for further investigation by users having technical expertise.
- The user, through its own analysis and testing, is solely responsible for making the final selection of the system and components and assuring that all performance, endurance, maintenance, safety and warning requirements of the application are met. The user must analyze all aspects of the application, follow applicable industry standards, and follow the information concerning the product in the current product catalog and in any other materials provided from Parker or its subsidiaries or authorized distributors.
- To the extent that Parker or its subsidiaries or authorized distributors provide component or system options based upon data or specifications provided by the user, the user is responsible for determining that such data and specifications are suitable and sufficient for all applications and reasonably foreseeable uses of the components or systems.

<b>Overview</b> .....	<b>5</b>
Typical Efficiency Maps .....	7
Motor Performance definitions .....	7
<b>Technical Characteristics</b> .....	<b>8</b>
GVM142 Low Voltage Windings - Natural Convection Cooling .....	8
GVM142 Low Voltage Windings - Liquid Cooling .....	8
GVM142 High Voltage windings - Liquid Cooling .....	9
Liquid Cooling Pressure Drop.....	9
<b>Dimensions</b> .....	<b>10</b>
GVK142 (Kit Version) .....	10
Standard Version (EHP Applications) .....	11
<b>Cable and Cooling Accessories</b> .....	<b>12</b>
<b>GVM Hoses</b> .....	<b>12</b>
<b>GVM Fittings</b> .....	<b>13</b>
<b>Order Code</b> .....	<b>14</b>



# Global Vehicle Motor - GVM142

## Overview

### Description

PMAC servomotors offer the best solution to meet the requirements of vehicle duty performance. The torque density and speed capabilities of Parker Permanent Magnet AC motors (PMAC) combined with a voltage-matched inverter provide the speed and torque required to achieve breakthrough performance in a variety of vehicle platforms. The GVM is a powerful choice for both on and off-road vehicles, engineered mainly for Electro-hydraulic Pumps (EHP) and auxiliary applications. The GVM motor line has been designed to be used in a wide variety of vehicle applications including; construction vehicles, refuse truck, city buses, street sweeper, motorcycles and scooters, light commercial vehicles and watercraft.

### Features

- High efficiency
- Compactness (High power density)
- Can be used either as motor or generator
- Operating voltages available from 24 to 800 VDC
- Rare earth magnets allow high temperature operation
- Patented water cooling system

### Typical Applications

- Electric motors/generators for hybrid applications
- Electric motors for motorbikes, scooters...
- Electro-hydraulic pumps for cylinders
- Auxiliary applications as fan/compressors for air conditioning

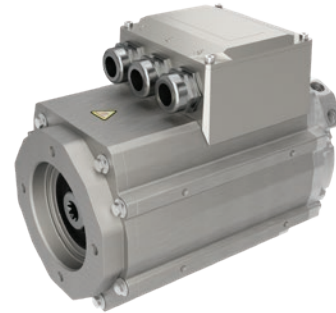

### Technical Characteristics - Overview

<b>Motor type</b>	Permanent Magnet synchronous motor
<b>Magnet materials</b>	Rare earth magnets
<b>Number of poles</b>	12
<b>Battery voltage</b>	24 to 800 VDC
<b>Power range</b>	up to 26.3 kW (continuous)
<b>Torque range</b>	up to 85 Nm (peak)
<b>Speed range</b>	up to 9750 min <sup>-1</sup>
<b>Ambient temperature<sup>1</sup></b>	liquid cooled: -40...+120 °C natural convection: -40...+65 °C
<b>Storage temperature<sup>1</sup></b>	-40...+120 °C
<b>Sensor</b>	Resolver or SinCos encoder
<b>Insulation of the stator winding</b>	Class H with potting
<b>Protection</b>	IP67 as standard IP6K9K on request <sup>2</sup>
<b>Thermal protection</b>	1 PTC probes and 1 KTY84-130 sensor
<b>Shaft end</b>	Female SAE A spline shaft, other possibilities on request
<b>Connections</b>	Terminal box (flying cables for kits); connector for feedback
<b>Marking</b>	CE

<sup>1</sup> With resolver as feedback

<sup>2</sup> When a pump is assembled on the front of the motor (with its own seal) the combination complies with IP6K9K protection

Note: In case of axial or radial load on the shaft, please consult the acceptable limits on the GVM technical manual.

## Overview

### Cooling System

- Enables high power density
- Advised cooling liquid: Water/Glycol 50% for the best compromise
- Circular stator comprising the cooling system can be inserted as a kit in any circular housing (Parker or customer)
- Natural convection cooling alternative available for low power / low speed



### Rugged Design

- Designed to be shock-proof, vibration-proof, salt spray resistant
- Gore vent: to avoid condensation in case of sudden T° variation or during storage at low T°
- Ambient T°: -40 °C to +120 °C (liquid cooling)
- IP67 standard; IP6K9K on request

## GVK Motors:

High customisation level requested. Only for high volumes and for OEM applications

- Available on request as a potted circular stator including the cooling system
- Provides the customer with a bespoke and integrated mechanical design
- GVK range has the same electrical characteristics as GVM range
- Parker is able to offer support in the integration of GVM kits, please contact us

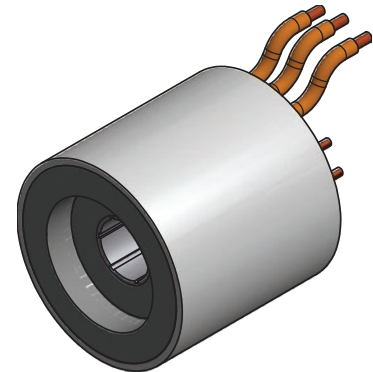

## Typical Efficiency Maps

### GVM Motors: an efficient range.

The PMAC efficiency is far higher than induction motor one of the same power range.

Only when using the best component technology and optimal design characteristics do traction motors/generators and controllers minimize losses both during motoring and power generation - increasing vehicle range.

Variable speed system allows higher efficiency even at low speed.

### GVM142-100 in Motor operation mode

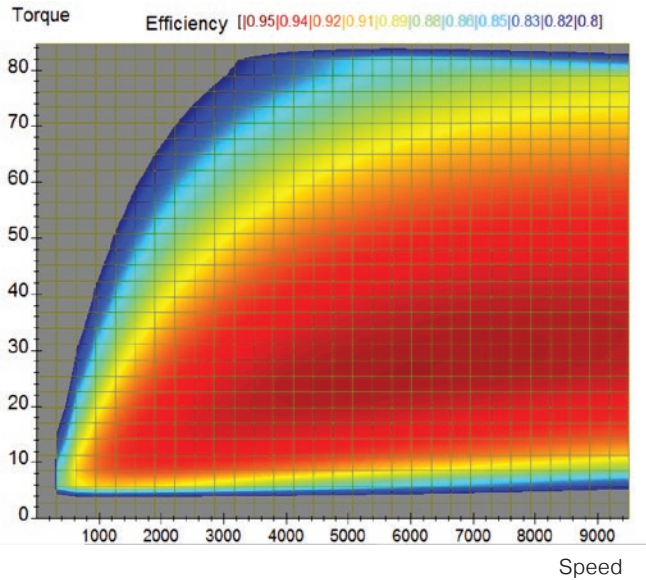

### GVM142-100 in Generator operation mode

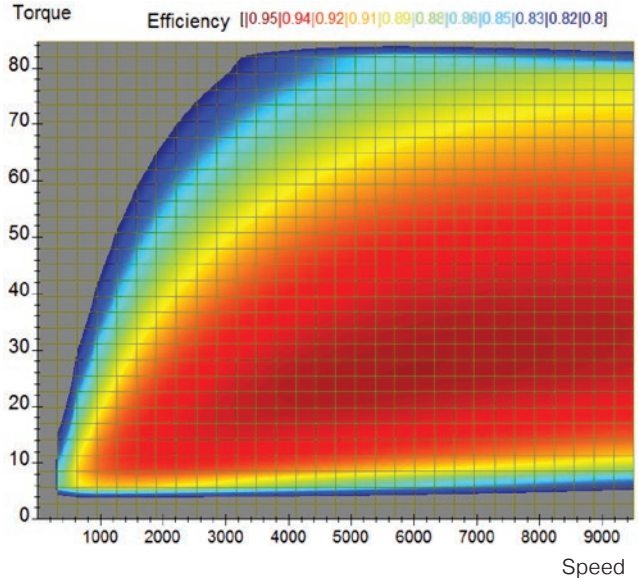

## Motor Performance definitions

GVM Series motors are designed to meet the power requirements in a wide variety of vehicle applications. The GVM has the ability to operate at different battery voltages without loss of power.

- From 24 to 800 VDC
- Numerous rotor lengths
- Multiple winding configurations per length

By selecting the appropriate voltage, rotor length and winding variation, the following parameters can be refined to match the vehicle's specific performance requirements:

- Peak torque
- Peak power
- Rated torque
- Rated speed
- Rated power
- Maximum speed

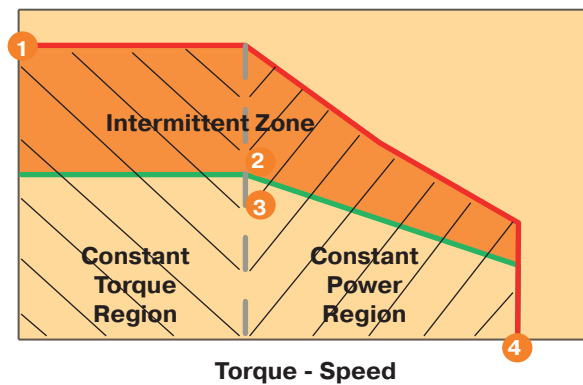

Parameters	Battery DC Voltage [V]	Rated Torque Mn [Nm]	Rated Power Pn [kW]	Rated Current In [Arms]	Rated Speed Nn [min <sup>-1</sup> ]	Peak Torque Mp [Nm]	Peak Power Pp [kW]	Peak Current Ip [Arms]	Maximum Speed Nmax [min <sup>-1</sup> ]
		2			3	1			4

## Technical Characteristics

### GVM142 Low Voltage Windings - Natural Convection Cooling

Motor	Battery DC Voltage [V]	Rated Torque Mn [Nm]	Rated Power Pn [kW]	Rated Current In [Arms]	Rated Speed Nn [min <sup>-1</sup> ]	Peak Torque Mp [Nm]	Peak Power Pp [kW]	Peak Current Ip [Arms]	Maximum Speed Nmax [min <sup>-1</sup> ]
GVM142-050-DPN	24	8.99	3.03	125	3220	40	7.2	691.1	3800
GVM142-050-GPN	36	6.74	3.18	87.1	4500	40	10.4	625.3	4900
GVM142-050-MPN	48	6.33	3.12	64	4700	40	10.9	486.4	5200
GVM142-050-YPN	72	6.74	3.18	42.6	4500	40	10.4	305.4	5000
GVM142-050-ZPN	80	6.12	3.08	37.2	4800	40	11.1	291.8	5200
GVM142-050-EQN	96	6.54	3.15	31.2	4600	40	10.6	230.4	4950
GVM142-050-NQN	120	7.87	3.22	26.1	3900	40	9.0	162.1	4400
GVM142-075-DPN	24	14.3	2.84	129	1890	62	6.7	715.4	2200
GVM142-075-DPN	36	9.36	3.43	87.5	3500	62	11.5	715.3	3500
GVM142-075-GPN	48	7.26	3.04	62.6	4000	62	14.3	647.1	4000
GVM142-075-YPN	72	10.8	3.52	44.3	3100	62	10.4	316.1	3100
GVM142-075-YPN	80	9.36	3.43	38.6	3500	62	11.7	316.1	3500
GVM142-075-ZPN	96	8.13	3.24	32.3	3800	62	13.6	302.0	3800
GVM142-075-EQN	120	8.13	3.24	25.5	3800	62	13.1	238.3	3800
GVM142-100-DPN	24	18.1	2.74	121	1440	85	6.9	742.6	1750
GVM142-100-DPN	36	14.8	3.57	101	2300	85	11.4	742.6	2700
GVM142-100-GPN	48	11.8	3.58	73.6	2900	85	14.2	671.9	3100
GVM142-100-YPN	72	15.5	3.49	46.3	2150	85	10.2	328.1	1350
GVM142-100-YPN	80	14.4	3.61	43.2	2400	85	11.5	328.1	2650
GVM142-100-ZPN	96	12.3	3.62	35.8	2800	85	13.5	313.5	3000
GVM142-100-DQN	120	11.8	3.58	29.2	2900	85	14.1	266.2	3100

### GVM142 Low Voltage Windings - Liquid Cooling

Motor	Battery DC Voltage [V]	Rated Torque Mn [Nm]	Rated Power Pn [kW]	Rated Current In [Arms]	Rated Speed Nn [min <sup>-1</sup> ]	Peak Torque Mp [Nm]	Peak Power Pp [kW]	Peak Current Ip [Arms]	Maximum Speed Nmax [min <sup>-1</sup> ]
GVM142-050-MPW	24	18.4	3.47	178	1800	40	4.6	486.7	2700
GVM142-050-MPW	36	18.2	5.73	177	3000	40	7.9	486.7	4500
GVM142-050-MPW	48	18.1	7.94	175	4200	40	11.0	486.7	6300
GVM142-050-MPW	72	17.6	12	172	6500	40	17.0	486.6	9750
GVM142-050-MPW	80	17.4	13.1	171	7200	40	18.9	486.6	9500
GVM142-050-YPW	96	17.8	10.1	109	5400	40	14.2	305.6	8100
GVM142-050-ZPW	120	17.6	11.8	103	6400	40	16.7	292.0	9500
GVM142-075-MPW	24	29	3.39	182	1110	62	4.4	503.6	1650
GVM142-075-MPW	36	29	5.81	183	1910	62	7.8	503.5	2850
GVM142-075-MPW	48	29	7.9	183	2600	62	10.9	503.5	3900
GVM142-075-MPW	72	28.5	12.3	181	4100	62	17.0	503.5	6150
GVM142-075-MPW	80	28.3	13.9	180	4700	62	19.1	503.5	7050
GVM142-075-MPW	96	28	16.4	178	5600	62	23.1	503.5	8400
GVM142-075-MPW	120	27.4	19.8	175	6900	62	28.4	503.5	9500
GVM142-100-MPW	24	40	3.38	187	806	85	3.9	523.0	1200
GVM142-100-MPW	36	40	5.88	187	1400	85	7.6	523.0	2100
GVM142-100-MPW	48	39.9	8.15	187	1950	85	10.7	523.0	2925
GVM142-100-MPW	72	39.4	12.4	185	3000	85	16.9	523.0	4500
GVM142-100-MPW	80	39.2	14	185	3400	85	19.0	523.0	5100
GVM142-100-MPW	96	38.8	17.1	183	4200	85	23.2	523.0	6300
GVM142-100-MPW	120	38.2	20.8	180	5200	85	28.6	523.0	7800

GVM Stator connected to a heat-exchange surface at 60 °C without water cooling

(Characteristics are given for an optimal drive / motor association without any limitation coming from the drive)

These products without liquid cooling are typically dedicated to EHP due to the low speed level available.

GVM Input cooling liquid at 65 °C (Characteristics are given for an optimal drive / motor association without any limitation coming from the drive) / (for alternative cooling temperatures please contact us)

## GVM142 High Voltage windings - Liquid Cooling

Motor	Battery DC Voltage [V]	Rated Torque Mn [Nm]	Rated Power Pn [kW]	Rated Current In [Arms]	Rated Speed Nn [min <sup>-1</sup> ]	Peak Torque Mp [Nm]	Peak Power Pp [kW]	Peak Current Ip [Arms]	Maximum Speed Nmax [min <sup>-1</sup> ]
GVM142-050-XQW	320	17.6	12.3	39	6700	40	17.3	110.4	9500
GVM142-050-DRW	400	17.6	12.2	30.7	6600	40	17.1	87.0	9500
GVM142-050-RRW	640	17.7	11.5	18.1	6220	40	16.1	51.1	8890
GVM142-075-NQW	320	27.6	18.5	58.8	6400	62	25.9	167.8	9500
GVM142-075-SQW	400	27.5	19.3	48.9	6700	62	27.2	140.1	9500
GVM142-075-XQW	480	27.5	19	39.9	6600	62	26.6	114.2	9500
GVM142-075-ERW	640	27.6	18.7	29.5	6500	62	26.3	84.4	9500
GVM142-100-EQW	320	37	26.3	83.1	6800	85	37.2	247.7	9500
GVM142-100-NQW	400	37.6	23.6	59.4	6000	85	32.8	174.3	9000
GVM142-100-SQW	480	37.6	23.6	49.6	6000	85	32.9	145.6	9000
GVM142-100-ZQW	640	37.5	23.8	37.2	6050	85	33.1	109.5	8570

GVM Input cooling liquid at 65 °C (Characteristics are given for an optimal inverter / motor association without any limitation coming from the drive)  
(for alternative cooling temperatures please contact us)

## Liquid Cooling Pressure Drop

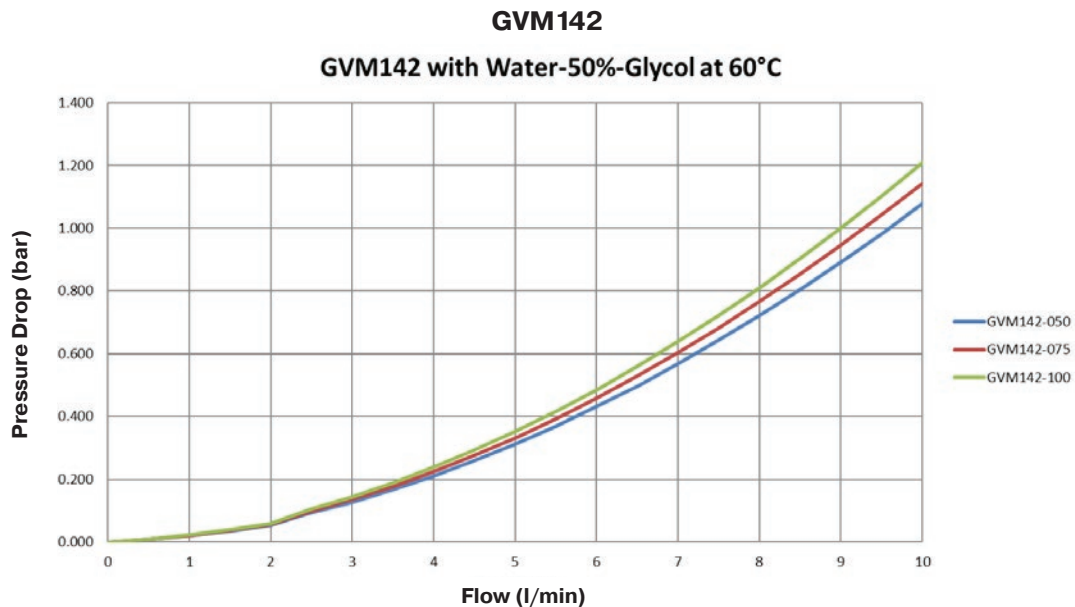

Please refer to the motor datasheet or technical manual for more information (PVD3668).  
For other types of cooling liquid thank you to consult us.

# Dimensions

## GVK142 (Kit Version) \*

High customisation level requested. Only for high volumes and for OEM applications

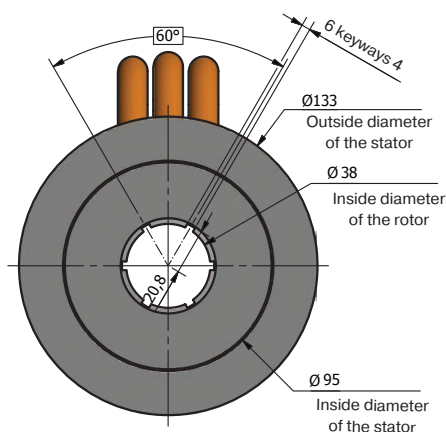
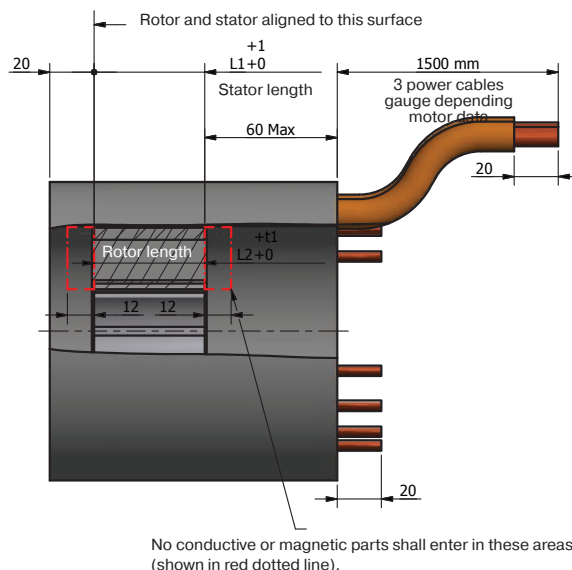
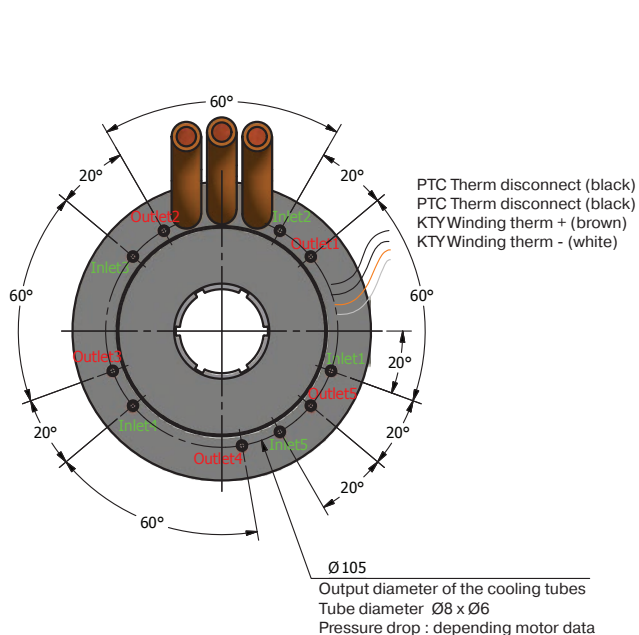

Motor size	L1 [mm]	L2 [mm]	t1	Weight [kg]
GVK142-075	75	75	1	8.5
GVK142-100	100	100	1	10.5
GVK142-150	150	150	1.5	14.5

### WARNING

The motor has to be shrunk in the customer housing by Parker  
Parker will support the customer to determine part dimensions

To have the pressure drop given by Parker:  
Connect all of the Inlet in // to the cooling system input  
Connect all of the Outlet in // to the cooling system output

\* Outside dimensions are subject to change depending on the winding symbol. For further information, please contact your local Parker representative.

## Standard Version (EHP Applications)

### GVM142 (SAE A)

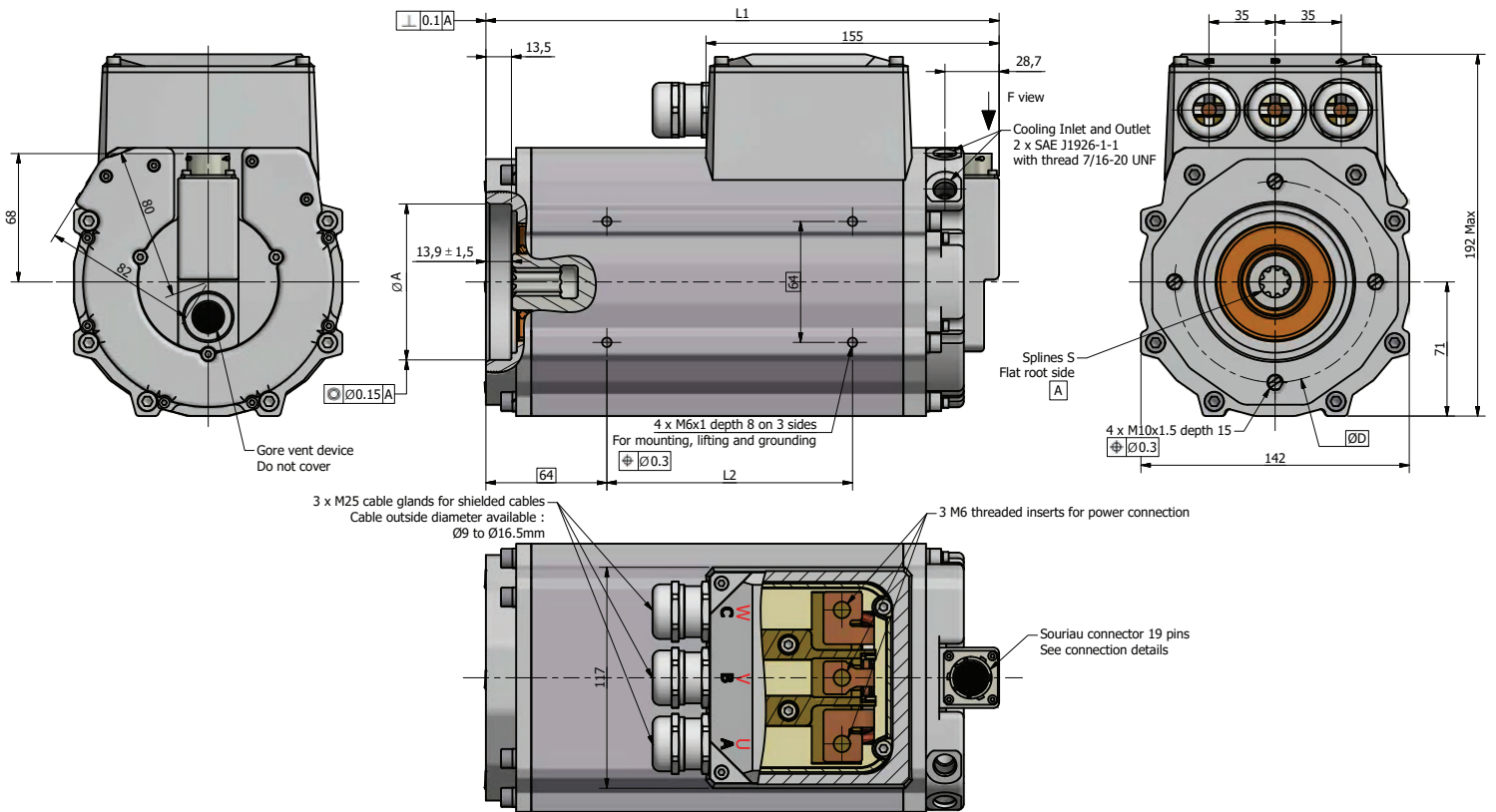

Motor size	L1 [mm]	L2 [mm]	Weight [kg]	SAE A
GVM142-050	225 max	80	16	x
GVM142-075	250 max	105	18.5	x
GVM142-100	275 max	130	20.5	x

#### Front interface data

SAE choice	$\varnothing A$	E	S
SAE A	$\varnothing 82.55$ G7	25	SAE A 9T 16/32 DP

## Cable and Cooling Accessories

### Sensor cable

Description	Order code *
Connector + sensor cable / SinCos <sup>(1)</sup>	<b>CBFSC0H0-SRX-000-xxx0-00</b>
Connector + sensor cable / Resolver	<b>CBFRE0H0-SRX-000-xxx0-00</b>

\* These 3 digits (xxx) indicate cable length in meters : 001, 002, 003 or 004 meters as standard.







<sup>(1)</sup> In case of SinCos encoder, take care to connect the cable shield to the vehicle chassis. The motor housing must be at the same potential than the drive body.

## GVM Hoses

We recommend to use the Parker Multipurpose Transfer Hose - Oilpress N/L 20-30 :



Part Number	 I.D. (mm)	 O.D. (mm)	 Max. Working Pressure			 Weight kg/m	 min. Bend Radius mm	in Stock
			MPa	psi	bar			
<b>OILPRESS N/L 20</b>								
IH30832000/40	6	12	2.0	300.0	20	0.12	25	Y
IH30832001/40	8	14	2.0	300.0	20	0.15	35	Y
IH30832002/40	10	17	2.0	300.0	20	0.21	40	Y
IH30832003/40	13	20	2.0	300.0	20	0.26	55	Y
IH30832004/40	16	23	2.0	300.0	20	0.31	65	Y
IH30832005/40	19	28	2.0	300.0	20	0.47	80	Y
IH30832006/40	25	36	2.0	300.0	20	0.74	100	Y

# GVM Fittings

To complete your installation some additional components like hose fittings, connectors, and hoses may be required. While we do not provide these items, your local Parker hose distributor can assist. Find one on [www.parker.com](http://www.parker.com).

## Coolant Connections

GVM142 : Coolant inlet / outlet are ORB-4 SAE J1926-1 with thread 7/16-20 UNF  
We advise to use the male stud, fittings and hose as follow :

For EO 24° cone end (DIN 3861 / ISO 8434-1) :

GVM Fittings			
Motor	P/N Fitting	T1	T
GVM142	GE10L7/16UNFOMDCF	7/16-20 UNF-2A	M16x1,5

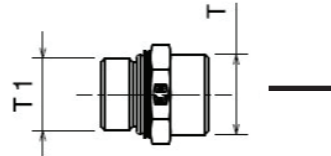

90° Elbow Fitting	
P/N	M
EW10LOMDCF	M16x1,5

Hose Fitting 47 series		
P/N	M	d
KCA47-10-5	M16x1,5	7,9

Nota : use with tube clamp not include

Hose Fitting 56 series		
P/N	M	d
1CA56-10-5	M16x1,5	7,9

90° Elbow Hose Fitting 47 series		
P/N	M	d
KCF47-10-5	M16x1,5	7,9

Nota : use with tube clamp not include

90° Elbow Hose Fitting 56 series		
P/N	M	d
1CF56-10-5	M16x1,5	7,9

## Order Code

	1	2	3	4	5	6	7	8	9	10	11
Order example	<b>GVM</b>	<b>142</b>	<b>100</b>	<b>AA</b>	<b>W</b>	<b>A</b>	<b>A</b>	<b>B</b>	<b>PA</b>	<b>1</b>	<b>E</b>

### 1 Motor series

<b>GVM</b>	Global Vehicle Motor
<b>GVK</b>	Global Vehicle Kit Motor (on request)

### 2 Frame size (outer width)

<b>142</b>	142 mm
------------	--------

### 3 Stack length\*

<b>050</b>	data see chapter
<b>075</b>	"Technical
<b>100</b>	Characteristics"

### 4 Winding symbol

....	see motor tables
------	------------------

### 5 Cooling system

<b>N</b>	Natural convection
<b>W</b>	Liquid cooling (please contact us for flow & cooling temperature data)

### 6 Feedback

<b>A</b>	Resolver (standard 2 poles)
<b>S</b>	Sin/Cos RM22A (low voltage applications)
<b>0</b>	No feedback sensor

### 7 Thermal switch

<b>A</b>	PTC
----------	-----

### 8 Thermal sensor

<b>B</b>	Equivalent to KTY84- 130 thermistor
----------	-------------------------------------

### 9 Interface

<b>PA</b>	EHP mount, SAE A, 2 holes
<b>00</b>	Kit version

### 10 Power connection

<b>1</b>	Terminal box
<b>2</b>	Flying cables (kit version only)

### 11 Options

<b>G</b>	Global (standard motor)
<b>E</b>	Europe (custom motor)

\* "Technical Characteristics" (page 8)



# Parker's Motion & Control Technologies

At Parker, we're guided by a relentless drive to help our customers become more productive and achieve higher levels of profitability by engineering the best systems for their requirements. It means looking at customer applications from many angles to find new ways to create value. Whatever the motion and control technology need, Parker has the experience, breadth of product and global reach to consistently deliver. No company knows more about motion and control technology than Parker. For further info call 00800 27 27 5374



## Aerospace

### Key Markets

Aftermarket services  
Commercial transports  
Engines  
General & business aviation  
Helicopters  
Launch vehicles  
Military aircraft  
Missiles  
Power generation  
Regional transports  
Unmanned aerial vehicles

### Key Products

Control systems & actuation products  
Engine systems & components  
Fluid conveyance systems & components  
Fluid metering, delivery & atomization devices  
Fuel systems & components  
Fuel tank inerting systems  
Hydraulic systems & components  
Thermal management  
Wheels & brakes



## Climate Control

### Key Markets

Agriculture  
Air conditioning  
Construction Machinery  
Food & beverage  
Industrial machinery  
Life sciences  
Oil & gas  
Precision cooling  
Process  
Refrigeration  
Transportation

### Key Products

Accumulators  
Advanced actuators  
CO<sub>2</sub> controls  
Electronic controllers  
Filter driers  
Hand shut-off valves  
Heat exchangers  
Hose & fittings  
Pressure regulating valves  
Refrigerant distributors  
Safety relief valves  
Smart pumps  
Solenoid valves  
Thermostatic expansion valves



## Electromechanical

### Key Markets

Aerospace  
Factory automation  
Life science & medical  
Machine tools  
Packaging machinery  
Paper machinery  
Plastics machinery & converting  
Primary metals  
Semiconductor & electronics  
Textile  
Wire & cable

### Key Products

AC/DC drives & systems  
Electric actuators, gantry robots & slides  
Electrohydraulic actuation systems  
Electromechanical actuation systems  
Human machine interface  
Linear motors  
Stepper motors, servo motors, drives & controls  
Structural extrusions



## Filtration

### Key Markets

Aerospace  
Food & beverage  
Industrial plant & equipment  
Life sciences  
Marine  
Mobile equipment  
Oil & gas  
Power generation & renewable energy  
Process  
Transportation  
Water Purification

### Key Products

Analytical gas generators  
Compressed air filters & dryers  
Engine air, coolant, fuel & oil filtration systems  
Fluid condition monitoring systems  
Hydraulic & lubrication filters  
Hydrogen, nitrogen & zero air generators  
Instrumentation filters  
Membrane & fiber filters  
Microfiltration  
Sterile air filtration  
Water desalination & purification filters & systems



## Fluid & Gas Handling

### Key Markets

Aerial lift  
Agriculture  
Bulk chemical handling  
Construction machinery  
Food & beverage  
Fuel & gas delivery  
Industrial machinery  
Life sciences  
Marine  
Mining  
Mobile  
Oil & gas  
Renewable energy  
Transportation

### Key Products

Check valves  
Connectors for low pressure fluid conveyance  
Deep sea umbilicals  
Diagnostic equipment  
Hose couplings  
Industrial hose  
Mooring systems & power cables  
PTFE hose & tubing  
Quick couplings  
Rubber & thermoplastic hose  
Tube fittings & adapters  
Tubing & plastic fittings



## Hydraulics

### Key Markets

Aerial lift  
Agriculture  
Alternative energy  
Construction machinery  
Forestry  
Industrial machinery  
Machine tools  
Marine  
Material handling  
Mining  
Oil & gas  
Power generation  
Refuse vehicles  
Renewable energy  
Truck hydraulics  
Turf equipment

### Key Products

Accumulators  
Cartridge valves  
Electrohydraulic actuators  
Human machine interfaces  
Hybrid drives  
Hydraulic cylinders  
Hydraulic motors & pumps  
Hydraulic systems  
Hydraulic valves & controls  
Hydrostatic steering  
Integrated hydraulic circuits  
Power take-offs  
Power units  
Rotary actuators  
Sensors



## Pneumatics

### Key Markets

Aerospace  
Conveyor & material handling  
Factory automation  
Life science & medical  
Machine tools  
Packaging machinery  
Transportation & automotive

### Key Products

Air preparation  
Brass fittings & valves  
Manifolds  
Pneumatic accessories  
Pneumatic actuators & grippers  
Pneumatic valves & controls  
Quick disconnects  
Rotary actuators  
Rubber & thermoplastic hose & couplings  
Structural extrusions  
Thermoplastic tubing & fittings  
Vacuum generators, cups & sensors



## Process Control

### Key Markets

Alternative fuels  
Biopharmaceuticals  
Chemical & refining  
Food & beverage  
Marine & shipbuilding  
Medical & dental  
Microelectronics  
Nuclear Power  
Offshore oil exploration  
Oil & gas  
Pharmaceuticals  
Power generation  
Pulp & paper  
Steel  
Water/wastewater

### Key Products

Analytical Instruments  
Analytical sample conditioning products & systems  
Chemical injection fittings & valves  
Fluoropolymer chemical delivery fittings, valves & pumps  
High purity gas delivery fittings, valves, regulators & digital flow controllers  
Industrial mass flow meters/ controllers  
Permanent no-weld tube fittings  
Precision industrial regulators & flow controllers  
Process control double block & bleeds  
Process control fittings, valves, regulators & manifold valves



## Sealing & Shielding

### Key Markets

Aerospace  
Chemical processing  
Consumer  
Fluid power  
General industrial  
Information technology  
Life sciences  
Microelectronics  
Military  
Oil & gas  
Power generation  
Renewable energy  
Telecommunications  
Transportation

### Key Products

Dynamic seals  
Elastomeric o-rings  
Electro-medical instrument design & assembly  
EMI shielding  
Extruded & precision-cut, fabricated elastomeric seals  
High temperature metal seals  
Homogeneous & inserted elastomeric shapes  
Medical device fabrication & assembly  
Metal & plastic retained composite seals  
Shielded optical windows  
Silicone tubing & extrusions  
Thermal management  
Vibration dampening

[www.parker.com](http://www.parker.com)



**European Headquarters**  
La Tuilière 6, 1163 Etoy,  
Switzerland  
Tel: +41 21 821 85 00

**Your authorized Distributor**