

General Description

4-Way, 3 Position, Closed Center Spool Valve.
 For additional information see Technical Tips on pages SV2-SV6.

Features

- Designed to operate double acting cylinders, pilot circuits and bi-directional motors, etc.
- High flow capacity with reduced space requirements
- High pressure capability to 350 Bar (5000 PSI)
- One piece cartridge housing ensures internal concentricity
- Coil: Waterproof, hermetically sealed, requires no O’Rings; Symmetrical coil can be reversed without affecting performance.
- Manual override available

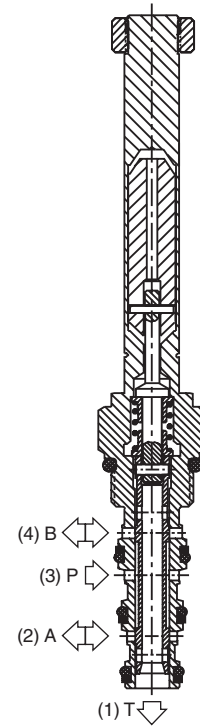
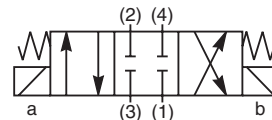
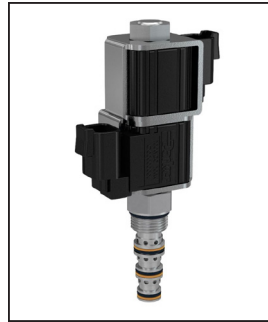

Specifications

Rated Flow	High Flow/Pressure ('SP' Coil) 17 LPM (4.5 GPM)
Maximum Inlet Pressure	'SP' Coil 350 Bar (5000 PSI)
Maximum Tank Pressure	210 Bar (3000 PSI)
Cartridge Material	All parts steel. All operating parts hardened steel.
Operating Temp. Range/Seals	-34°C to +121°C (Nitrile) (-30°F to +250°F) -26°C to +204°C (Fluorocarbon) (-15°F to +400°F)
Fluid Compatibility/ Viscosity	Mineral-based or synthetic with lubricating properties at viscosities of 45 to 2000 SSU (6 to 420 cSt)
Filtration	ISO 4406 18/ 16/13, SAE Class 4
Approx. Weight	.18 kg (.40 lbs.)
Cavity	C08-4 (See BC Section for more details)

Performance Curves

Pressure Drop vs. Flow (Through cartridge only)

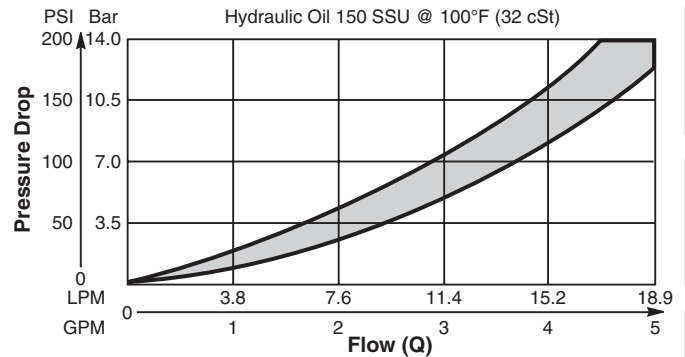

Operating Limits (Measured at 75% of Nominal Current)

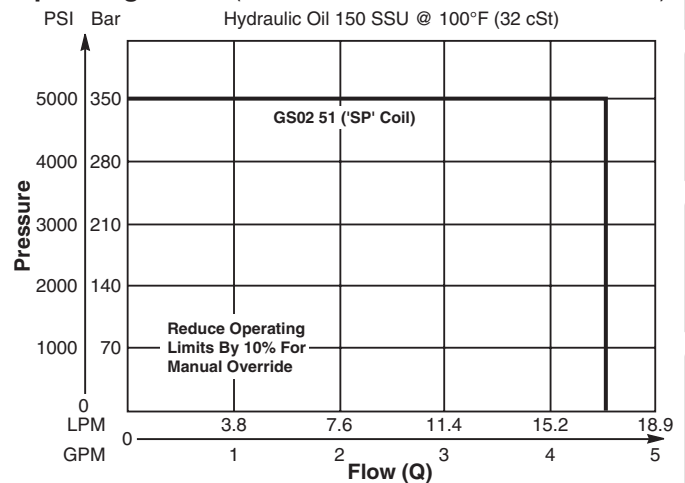

CV
Check Valves
SH
Shuttle Valves
LM
Load/Motor Controls
FC
Flow Controls
PC
Pressure Controls
LE
Logic Elements
DC
Directional Controls
SV
Solenoid Valves
PV
Proportional Valves
CE
Coils & Electronics
BC
Bodies & Cavities
TD
Technical Data

Dimensions Millimeters (Inches)

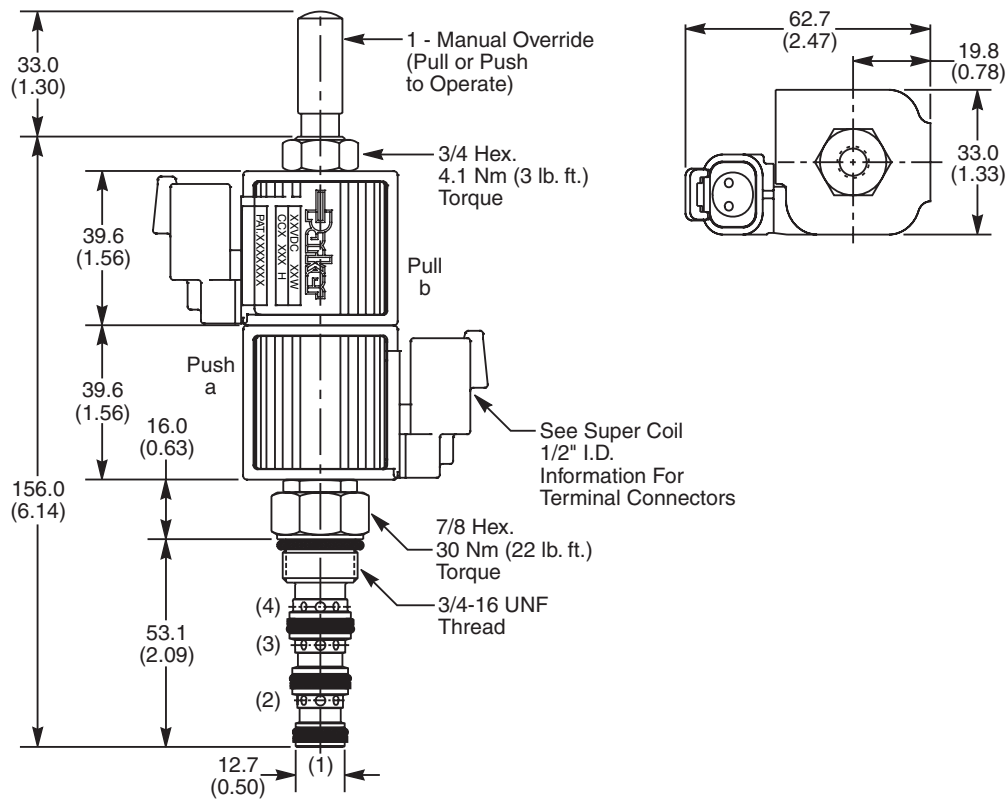

Ordering Information

GS02	51		0	N
08 Size Solenoid Valve	Style	Override Option	Screen	Seals

Highlighted represents preferred options that offer the shortest lead times. Other options may be available, but at extended lead times.

Coil(s) sold separately. Please see section CE of this catalog, 1/2" Super-Coil (CC series), for ordering information.

Code	Style
51	High Flow and Pressure ('SP' Coil)

Code	Screen
0	Not Available

Code	Override Options
0	None
1	Manual Override

Code	Seals
N	Nitrile

Order Bodies Separately
 See section BC

B08	—	4	—	6T
08 size		4-Way Cavity		Port Size

Code	Port Size / Body Material
6T	SAE-6 / Steel (5000 PSI)

Kit	Part Number
Nitrile Seal	SK30078N-1
Fluorocarbon Seal	SK30078V-1

CV
Check Valves

SH
Shuttle Valves

LM
Load/Motor Controls

FC
Flow Controls

PC
Pressure Controls

LE
Logic Elements

DC
Directional Controls

SV
Solenoid Valves

PV
Proportional Valves

CE
Coils & Electronics

BC
Bodies & Cavities

TD
Technical Data