

General Description

Pilot Operated Sequence Valve (Internally Piloted, Externally Drained).
 For additional information see Technical Tips on pages PC3-PC7.

Features

- Hardened, precision ground parts for durability
- Low profile adapter for minimal space requirements
- Fully guided poppet for more consistent reseal
- Steel adapters are zinc plated
- Polyurethane “D”-Ring eliminates backup rings and prevents hydrolysis
- Internal screening protects pilot spring from debris

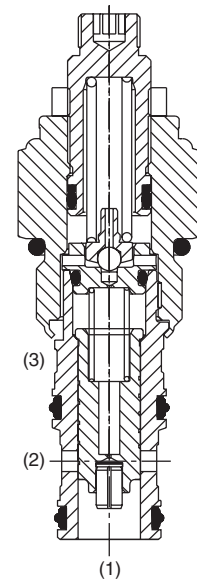
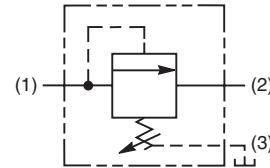

Specifications

Rated Flow	56.3 LPM (15 GPM)
Maximum Inlet Pressure	380 Bar (5500 PSI)
Maximum Pressure Setting	350 Bar (5000 PSI)
Sensitivity: Pressure/Turn	10 19.6 Bar (285 PSI) 30 58.9 Bar (859 PSI) 50 131.7 Bar (1910 PSI)
Maximum Tank Pressure	350 Bar (5000 PSI)
Maximum Drain Flow (Port 3)	0.94 LPM (0.25 GPM)
Reseat Pressure	90% of crack pressure
Leakage at 150 SSU (32 cSt)	82 cc/min. (5 cu. in./min.) @ 210 Bar (3000 PSI)
Cartridge Material	All parts steel. All operating parts hardened steel.
Operating Temp. Range/Seals	-37°C to +93°C (“D”-Ring) (-35°F to +200°F) -34°C to +121°C (Nitrile) (-30°F to +250°F) -26°C to +204°C (Fluorocarbon) (-15°F to +400°F)
Fluid Compatibility/Viscosity	Mineral-based or synthetic with lubricating properties at viscosities of 45 to 2000 SSU (6 to 420 cSt)
Filtration	ISO-4406 18/16/13, SAE Class 4
Approx. Weight	0.45 kg (1.0 lbs.)
Cavity	C10-3 (See BC Section for more details)

Performance Curves

Flow vs. Inlet Pressure

(Pressure rise through cartridge only)

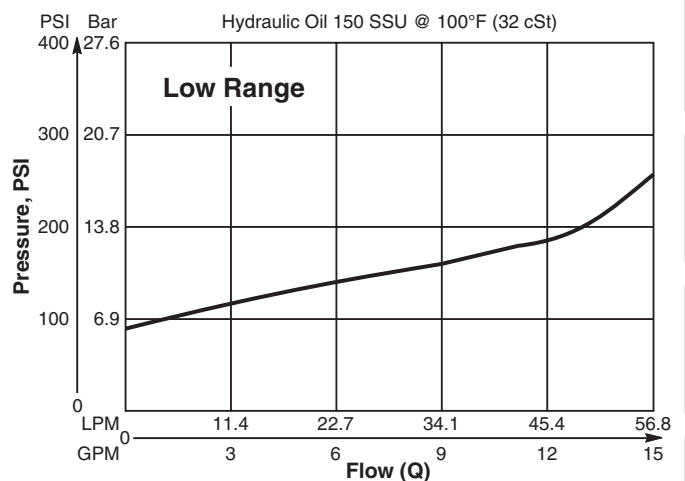
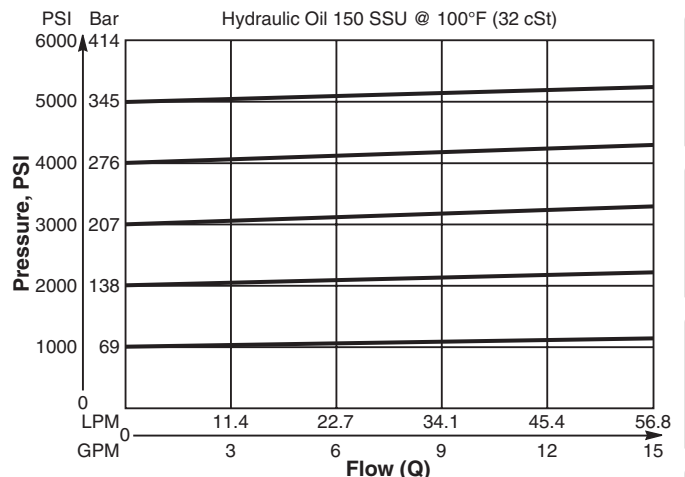

- CV**
Check Valves
- SH**
Shuttle Valves
- LM**
Load/Motor Controls
- FC**
Flow Controls
- PC**
Pressure Controls
- LE**
Logic Elements
- DC**
Directional Controls
- SV**
Solenoid Valves
- PV**
Proportional Valves
- CE**
Coils & Electronics
- BC**
Bodies & Cavities
- TD**
Technical Data

Dimensions Millimeters (Inches)

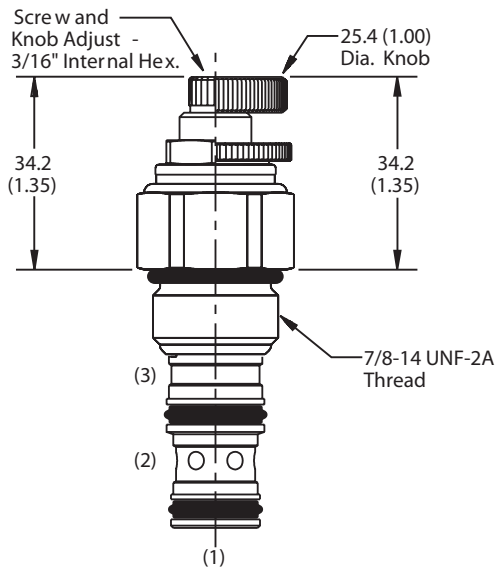

Screw/Knob Version

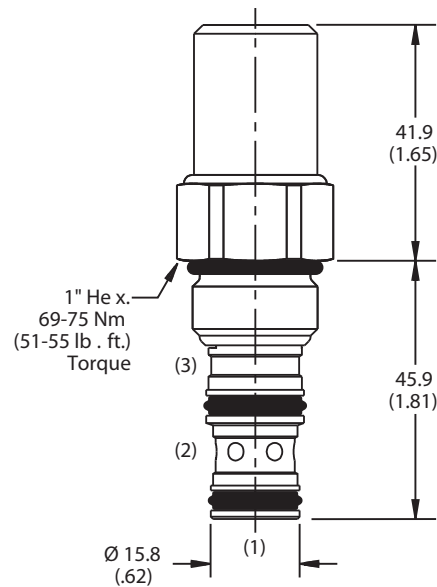

Tamper Resistant Version

Ordering Information

SVH101	S	<input type="checkbox"/>
10 Size P.O. Sequence Valve (Internal Pilot)	Adjustment Style	Pressure Range

Highlighted represents preferred options that offer the shortest lead times. Other options may be available, but at extended lead times.

Code	Adjustment Style
S	Screw Adjust

Code	Seals
Omit	D-Ring

Code	Pressure Range
10	6.9 - 69 Bar (100 - 1000 PSI) Standard Setting: 34.5 Bar (500 PSI) @ crack pressure, approximately .95 LPM (.25 GPM)
30	13.8 - 207 Bar (200 - 3000 PSI) Standard Setting: 103.5 Bar (1500 PSI) @ crack pressure, approximately .95 LPM (.25 GPM)
50	13.8 - 345 Bar (200 - 5000 PSI) Standard Setting: 172.4 Bar (2500 PSI) @ crack pressure, approximately .95 LPM (.25 GPM)

Kit	Part Number
Knob	717784-10
Tamper Resistant Cap	718083
D-Ring Seal	SK10-3
Nitrile Seal	SK10-3
Fluorocarbon Seal	SK10-3V

Order Bodies Separately
 See section BC

B10	-	3	-	8T
10 size		3-Way Cavity		Port Size

Code	Porting / Body Material
8T	SAE-8 / Steel (5000 PSI)

CV
Check Valves
SH
Shuttle Valves
LM
Load/Motor Controls
FC
Flow Controls
PC
Pressure Controls
LE
Logic Elements
DC
Directional Controls
SV
Solenoid Valves
PV
Proportional Valves
CE
Coils & Electronics
BC
Bodies & Cavities
TD
Technical Data