

- CV**
Check Valves
- SH**
Shuttle Valves
- LM**
Load/Motor Controls
- FC**
Flow Controls
- PC**
Pressure Controls
- LE**
Logic Elements
- DC**
Directional Controls
- MV**
Manual Valves
- SV**
Solenoid Valves
- PV**
Proportional Valves
- CE**
Coils & Electronics
- CB**
Cartridge Bodies
- BC**
Bodies & Cavities
- TD**
Technical Data

General Description

2-Way, 2 Position, Normally Open, Bi-Directional Poppet Valve. For additional information see Technical Tips on pages SV1-SV5.

Features

- Built-in thermal relief set at 36 Bar (500 PSI) above rated pressure
- One piece cartridge housing ensures internal concentricity
- Coil: Waterproof, hermetically sealed, requires no O’Rings; Coil is interchangeable with 04 and 06 series poppet valves; Symmetrical coil can be reversed without affecting performance.

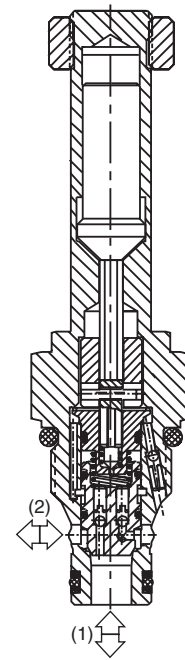
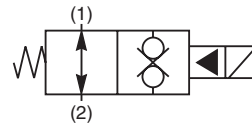

Specifications

Rated Flow	2 to 1 34 LPM (9 GPM) 1 to 2 19 LPM (5 GPM)
Maximum Inlet Pressure	85 210 Bar (3000 PSI) 86 350 Bar (5000 PSI)
Leakage at 150 SSU (32 cSt)	5 drops/min. (.33 cc/min.)
Minimum Operating Voltage	85% of rated voltage at 20°C (72°F).
Response Time	Open 40 ms Close 40 ms
Cartridge Material	All parts steel. All operating parts hardened steel.
Operating Temp. Range/Seals	-34°C to +121°C (Nitrile) (-30°F to +250°F) -26°C to +204°C (Fluorocarbon) (-15°F to +400°F)
Fluid Compatibility/Viscosity	Mineral-based or synthetic with lubricating properties at viscosities of 45 to 2000 SSU (6 to 420 cSt)
Filtration	ISO 4406 18/16/13, SAE Class 4
Approx. Weight	.14 kg (.31 lbs.)
Cavity	C08-2 (See BC Section for more details)

Performance Curve

Pressure Drop vs. Flow (Through cartridge only)

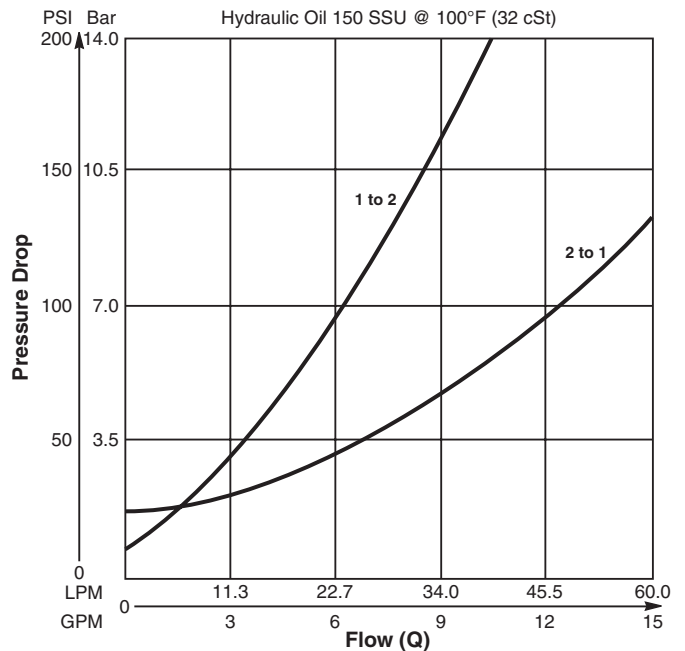

Dimensions Millimeters (Inches)

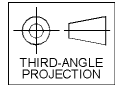
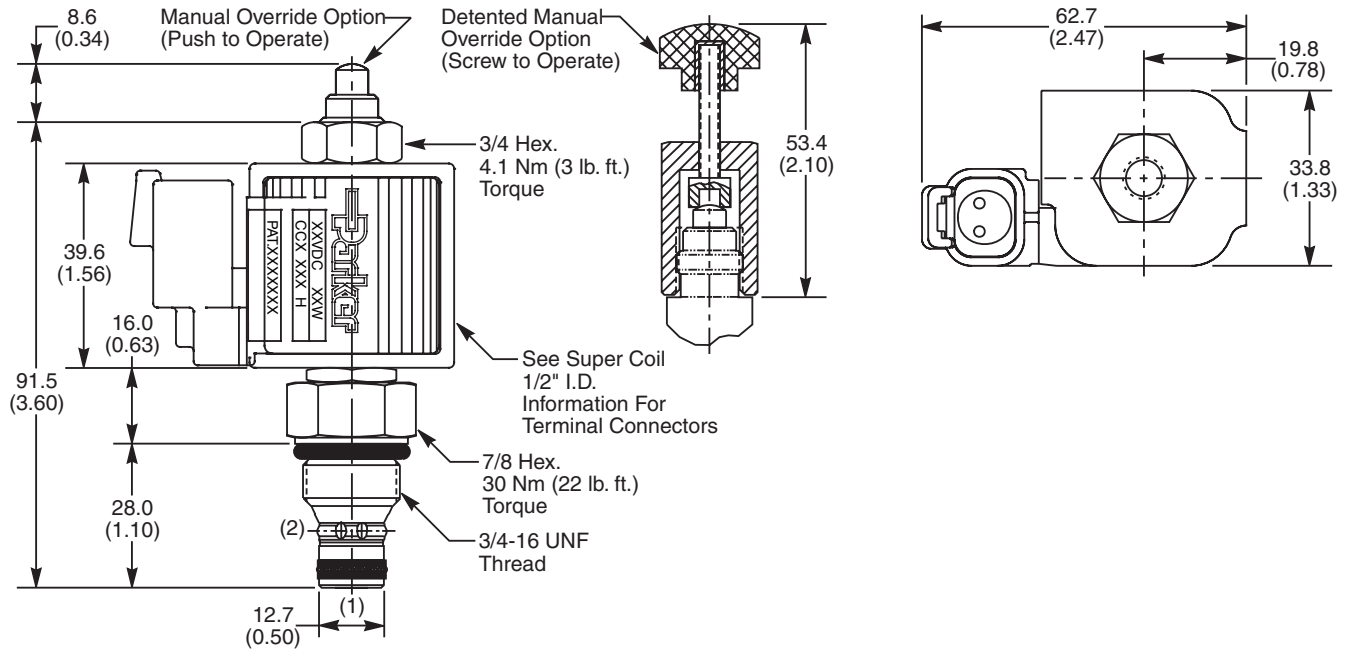

Ordering Information

GS02			0	N
08 Size Solenoid Valve	Style Normally Open	Override Option	Screen	Seals

Highlighted represents preferred options that offer the shortest lead times. Other options may be available, but at extended lead times.

Coil(s) sold separately. Please see section CE of this catalog, 1/2" Super-Coil (CC series), for ordering information.

Code	Style
85	Standard ('SS' Coil)
86	High Pressure ('SP' Coil)

Code	Screen
0	None

Code	Override Options
0	None
1	Manual Override
2	Detented Part No. 900690

Code	Seals / Kit No.
N	Nitrile / Buna-N (Std.) (SK30088N-1)

Order Bodies Separately
 See section BC

B08	-	2	-	
08 size		2-Way Cavity		Port Size

Code	Port Size / Body Material
6T	SAE-6 / Steel (5000 PSI)
A6T	SAE-6 / Aluminium (3000 PSI)

- CV Check Valves
- SH Shuttle Valves
- LM Load/Motor Controls
- FC Flow Controls
- PC Pressure Controls
- LE Logic Elements
- DC Directional Controls
- MV Manual Valves
- SV Solenoid Valves
- PV Proportional Valves
- CE Coils & Electronics
- CB Cartrak Bodies
- BC Bodies & Cavities
- TD Technical Data