

General Description

2 Way, Normally Closed, Proportional Poppet Valve with Pressure Compensation. For additional information see Technical Tips on pages PV1-PV5.

Features

- Low leakage poppet design with no dynamic seal to wear out on the compensator
- Adjusted at factory for low variation
- Coil: Waterproof, hermetically sealed, requires no O'Rings; Symmetrical coil can be reversed without affecting performance.
- External surfaces plated
- Excellent low flow metering capability

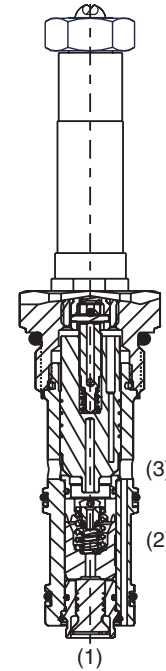
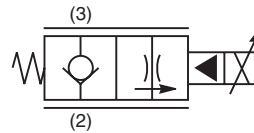

Note: Port 1 not used

Specifications

All performance data with CAS coil.
 Maximum current, 70% recommended.
 Hydraulic oil 150 SSU @ 40°C (32 cSt)

Rated Flow @ 70% of Full Current at ΔP 34.5 Bar (500 PSI)	57 LPM (15 GPM)
Maximum Input Pressure at Port 2	210 Bar (3000 PSI)
Minimum Pressure Differential	34 Bar (500 PSI)
Maximum Internal Leakage	5 drops/min. (.33 cc/min.) @ 210 Bar (3000 PSI)
Hysteresis @ 100 Hz PWM	<10% NOTE: Current regulated PWM recommended
Cartridge Material	All parts steel. All operating parts hardened steel.
Operating Temp. Range/Seals	-34°C to +121°C (Nitrile) (-30°F to +250°F) -26°C to +204°C (Fluorocarbon) (-15°F to +400°F)
Fluid Compatibility/Viscosity	Mineral-based or synthetic with lubricating properties at viscosities of 45 to 2000 SSU (6 to 420 cSt)
Filtration	ISO-4406 18/16/13, SAE Class 4
Approx. Weight	0.36 kg (0.79 lbs.)
Cavity	C12-3L (See BC Section for more details)

Performance Curves

Pressure Compensation of Regulated Flow

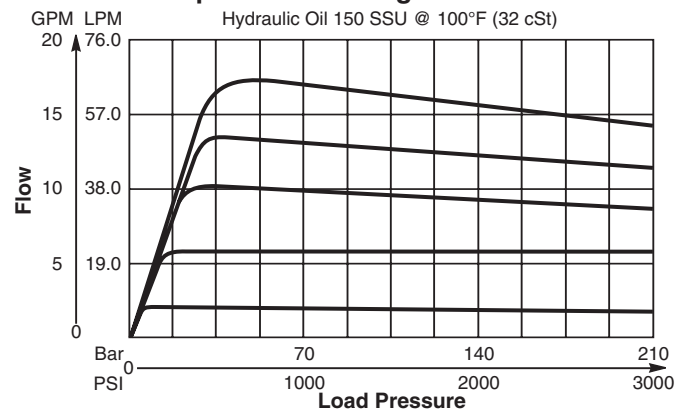

Flow vs. Input Current

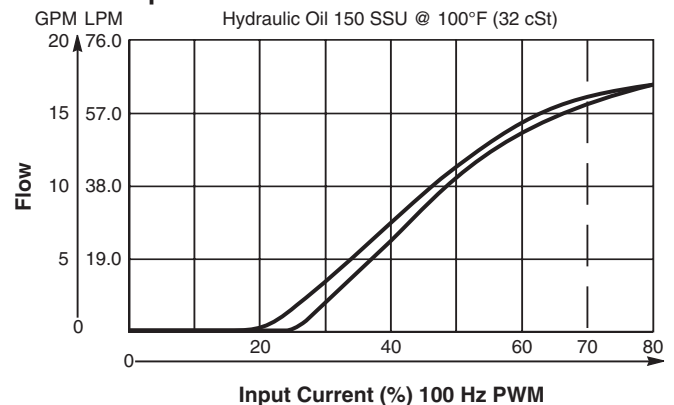

Dimensions Millimeters (Inches)

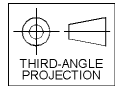
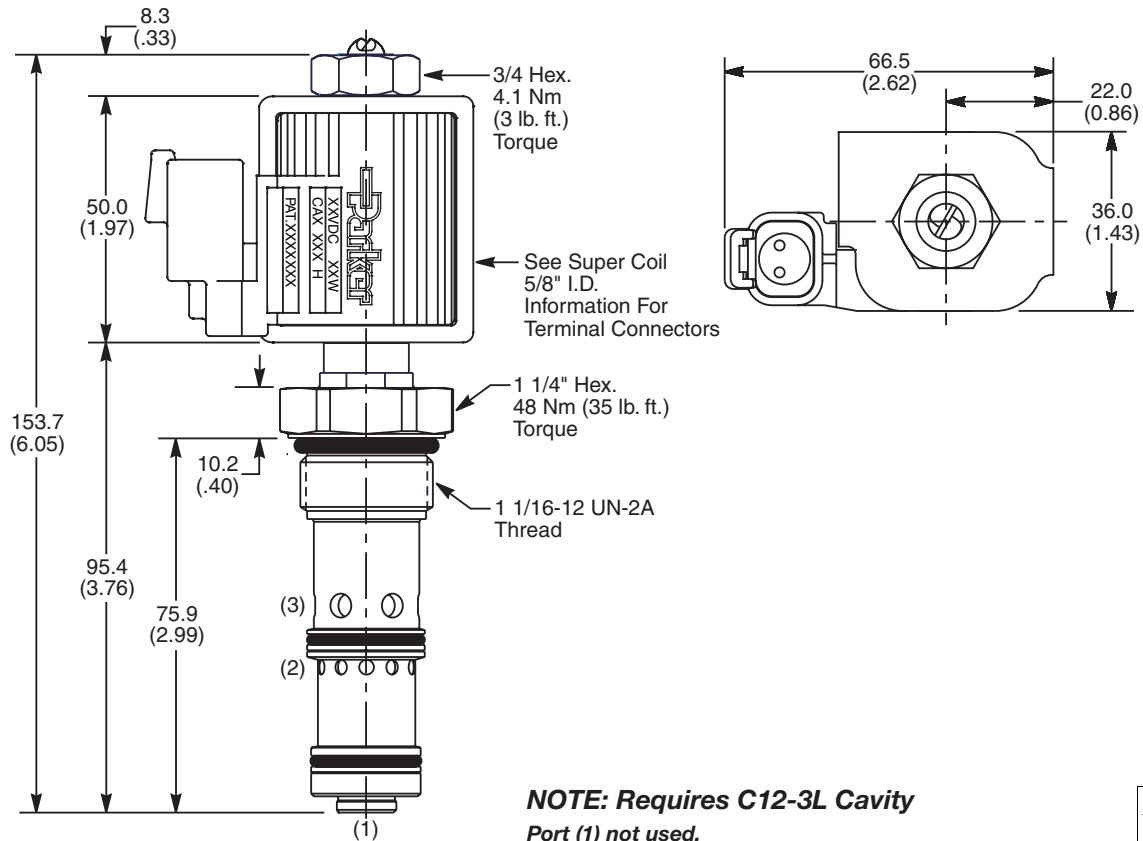

Ordering Information

FAPC121	C	
12 Size Proportional Valve	Style	Seals

Highlighted represents preferred options that offer the shortest lead times. Other options may be available, but at extended lead times.

Coil(s) sold separately. Please see section CE of this catalog, 5/8" Coil (CA series), for ordering information.

Code	Style
C	Normally Closed

Code	Seals / Kit No.
N	Nitrile / Buna-N (SK12-3LN)
V	Fluorocarbon / (SK12-3LV)

Order Bodies Separately
 See section BC

B12	—	3L	—	
12 size		3-Way Cavity		Port Size

Code	Porting / Body Material
12T	SAE-12 / Steel (5000 PSI)
A12T	SAE-12 / Aluminium (3000 PSI)



- CV
- Check Valves
- SH
- Shuttle Valves
- LM
- Load/Motor Controls
- FC
- Flow Controls
- PC
- Pressure Controls
- LE
- Logic Elements
- DC
- Directional Controls
- MV
- Manual Valves
- SV
- Solenoid Valves
- PV
- Proportional Valves
- CE
- Coils & Electronics
- CB
- Cartrp. Bodies
- BC
- Bodies & Cavities
- TD
- Technical Data