

- CV**
Check Valves
- SH**
Shuttle Valves
- LM**
Load/Motor Controls
- FC**
Flow Controls
- PC**
Pressure Controls
- LE**
Logic Elements
- DC**
Directional Controls
- MV**
Manual Valves
- SV**
Solenoid Valves
- PV**
Proportional Valves
- CE**
Coils & Electronics
- CB**
Cartridge Bodies
- BC**
Bodies & Cavities
- TD**
Technical Data

General Description

Poppet Type, Bi-Directional, Normally Closed, Pilot to Close Logic Element. For additional information see Technical Tips on pages LE1-LE6.

Features

- Hardened, precision ground parts for durability
- Polyurethane seals only
- No backup rings
- Low leakage design
- All external parts zinc plated
- Port 2 to 1 is the preferred flow path

Performance Curve

Pressure Drop vs. Flow (Through cartridge only)

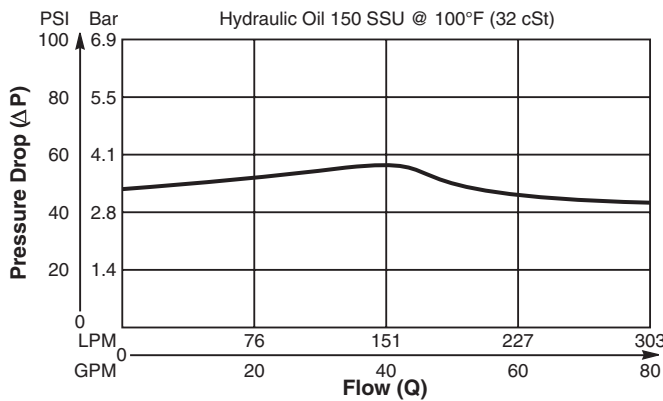

Specifications

Rated Flow	303 LPM (80 GPM)
Maximum Inlet Pressure	240 Bar (3500 PSI)
Leakage @ 150 SSU (32 cst)	5 drops/min. (.33 cc/min.) @ 240 Bar (3500 PSI)
Cartridge Material	All parts steel. All operating parts hardened steel.
Operating Temp. Range/Seals	-37°C to +107°C (Polyurethane, EPS) (-35°F to +225°F) -26°C to +204°C (Fluorocarbon) (-15°F to +400°F)
Fluid Compatibility/Viscosity	Mineral-based or synthetic with lubricating properties at viscosities of 45 to 2000 SSU (6 to 420 cSt)
Filtration	ISO-4406 18/16/13, SAE Class 4
Approx. Weight	.81 kg (1.78 lbs.)
Cavity	C20-3S (See BC Section for more details)
Form Tool	Rougher NFT20-3SR Finisher NFT20-3SF

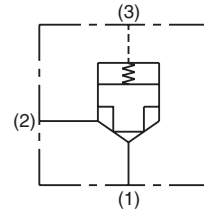
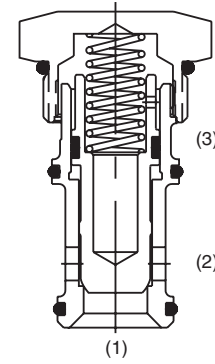

Dimensions

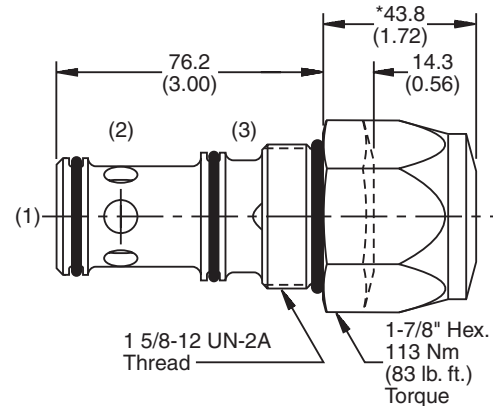

Ordering Information

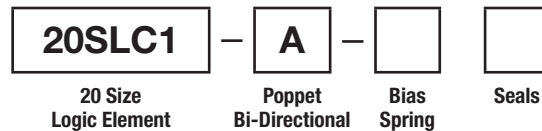

Highlighted represents preferred options that offer the shortest lead times. Other options may be available, but at extended lead times.

Code	Bias Spring
25	1.7 Bar (25 PSI)
50	3.5 Bar (50 PSI)
*75	5.2 Bar (75 PSI)
*100	6.9 Bar (100 PSI)
*150	10.3 Bar (150 PSI)

Code	Seals / Kit No.
Omit	Polyurethane, EPS (Std.) / (WRK-20-3S)
V	Fluorocarbon / (WRK-20-3S-W)

*Indicates larger cap height, see drawing.