

**General Description**

Poppet Type, Bi-Directional, Normally Closed, Pilot to Close Logic Element. For additional information see Technical Tips on pages LE1-LE6.

**Features**

- Hardened, precision ground parts for durability
- Polyurethane seals only
- No backup rings
- Low leakage design
- All external parts zinc plated
- Port 2 to 1 is the preferred flow path

**Performance Curve**

**Pressure Drop vs. Flow** (Through cartridge only)

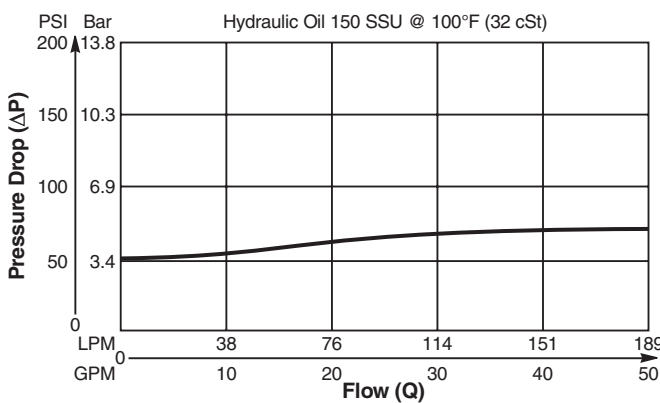

**Specifications**

<b>Rated Flow</b>	189 LPM (50 GPM)
<b>Maximum Inlet Pressure</b>	240 Bar (3500 PSI)
<b>Leakage @ 150 SSU (32 cst)</b>	5 drops/min. (.33 cc/min.) @ 240 Bar (3500 PSI)
<b>Cartridge Material</b>	All parts steel. All operating parts hardened steel.
<b>Operating Temp. Range/Seals</b>	-37°C to +107°C (Polyurethane, EPS) (-35°F to +225°F) -26°C to +204°C (Fluorocarbon) (-15°F to +400°F)
<b>Fluid Compatibility/Viscosity</b>	Mineral-based or synthetic with lubricating properties at viscosities of 45 to 2000 SSU (6 to 420 cSt)
<b>Filtration</b>	ISO-4406 18/16/13, SAE Class 4
<b>Approx. Weight</b>	.33 kg (.78 lbs.)
<b>Cavity</b>	C16-3S (See BC Section for more details)
<b>Form Tool</b>	Rougher NFT16-3SR Finisher NFT16-3SF

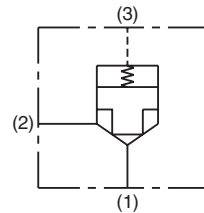
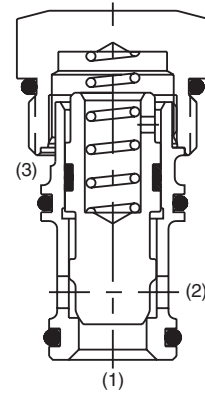

**Dimensions** Millimeters (Inches)

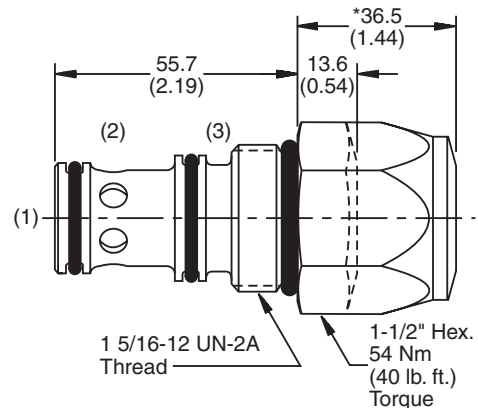

**Ordering Information**

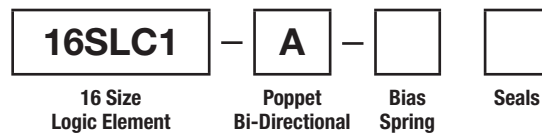

**Highlighted** represents preferred options that offer the shortest lead times. Other options may be available, but at extended lead times.

Code	Bias Spring
25	1.7 Bar (25 PSI)
50	3.5 Bar (50 PSI)
75	5.2 Bar (75 PSI)
<b>*100</b>	<b>6.9 Bar (100 PSI)</b>
<b>*150</b>	<b>10.3 Bar (150 PSI)</b>

Code	Seals / Kit No.
<b>Omit</b>	<b>Polyurethane, EPS (Std.) / (WRK-16-3S)</b>
V	Fluorocarbon / (WRK-16-3S-W)

\*Indicates larger cap height, see drawing.

- CV Check Valves
- SH Shuttle Valves
- LM Load/Motor Controls
- FC Flow Controls
- PC Pressure Controls
- LE Logic Elements**
- DC Directional Controls
- MV Manual Valves
- SV Solenoid Valves
- PV Proportional Valves
- CE Coils & Electronics
- CB Cartridge Bodies
- BC Bodies & Cavities
- TD Technical Data