

General Description

Cartridge Style Check Valve.
 For additional information see
 Technical Tips on pages CV1-CV2.



Features

- Spherical poppet for low leakage
- "D"-Ring eliminates back-up rings
- Dual sense paths for reduced ΔP
- All external parts zinc plated

Performance Curve

Pressure Drop vs. Flow (Through cartridge only)

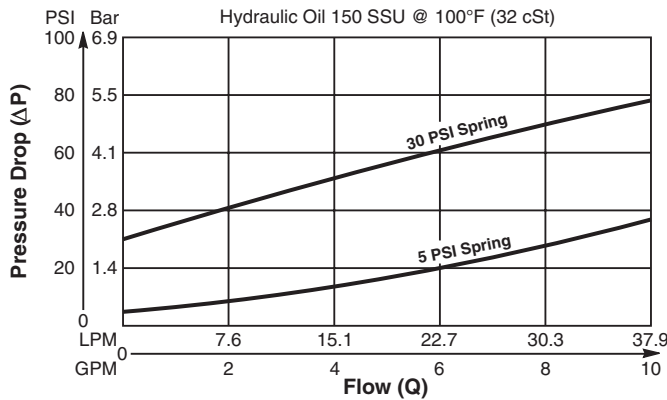

Specifications

Rated Flow	38 LPM (10 GPM)
Maximum Inlet Pressure	350 Bar (5000 PSI)
Leakage at 150 SSU (32 cSt)	2 drops/min. (0.13 cc/min) at 350 Bar (5000 PSI)
Cartridge Material	All parts steel. All operating parts hardened steel.
Operating Temp. Range/Seals	-37°C to +93°C ("D"-Ring) (-35°F to +200°F) -34°C to +121°C (Nitrile) (-30°F to +250°F) -26°C to +204°C (Fluorocarbon) (-15°F to +400°F)
Fluid Compatibility/Viscosity	Mineral-based or synthetic with lubricating properties at viscosities of 45 to 2000 SSU (6 to 420 cSt)
Filtration	ISO-4406 18/16/13, SAE Class 4
Approx. Weight	0.10 kg (0.2 lbs.)
Cavity	C08-2 (See BC Section for more details)
Form Tool	Rougher None Finisher NFT08-2F

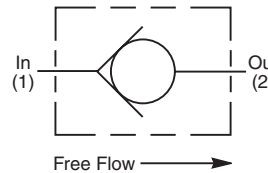
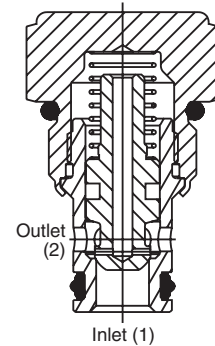

Dimensions Millimeters (Inches)

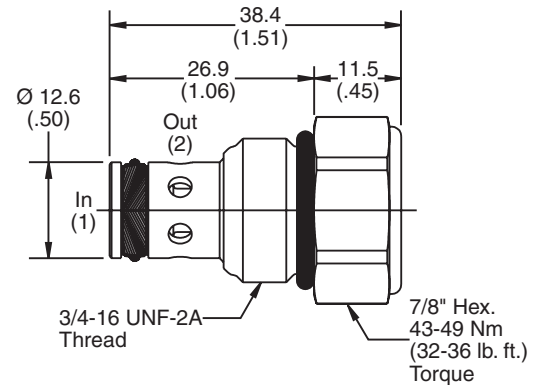

Ordering Information

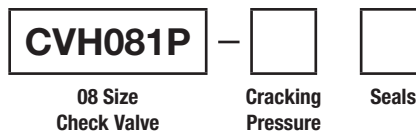

Highlighted represents preferred options that offer the shortest lead times. Other options may be available, but at extended lead times.

Code	Cracking Pressure
Omit	0.3 Bar (5 PSI)
10	0.7 Bar (10 PSI)
30	2.1 Bar (30 PSI)
65	4.5 Bar (65 PSI)
100	6.9 Bar (100 PSI)
150	10.4 Bar (150 PSI)

Code	Seals / Kit No.
Omit	"D"-Ring / (SK08-2)
N	Nitrile / (SK08-2)
V	Fluorocarbon / (SK08-2V)

Order Bodies Separately
 See section BC



Code	Porting / Body Material
6T	SAE-6 / Steel (5000 PSI)
A6T	SAE-6 / Aluminium (3000 PSI)

CV	Check Valves
SH	Shuttle Valves
LM	Load/Motor Controls
FC	Flow Controls
PC	Pressure Controls
LE	Logic Elements
DC	Directional Controls
MV	Manual Valves
SV	Solenoid Valves
PV	Proportional Valves
CE	Coils & Electronics
CB	Cartrpак Bodies
BC	Bodies & Cavities
TD	Technical Data