

Technical Information

- CV** Check Valves
- SH** Shuttle Valves
- LM** Load/Motor Controls
- FC** Flow Controls
- PC** Pressure Controls
- LE** Logic Elements
- DC** Directional Controls
- MV** Manual Valves
- SV** Solenoid Valves
- PV** Proportional Valves
- CE** Coils & Electronics
- BC** Bore/ies & Cavities
- TD** Technical Data

General Description

2 Way, Normally Closed, Proportional Flow Regulator Valve. Partially Pressure Compensated. For additional information see Technical Tips on pages PV1-PV6.

Features

- Analog Proportional Partially Pressure Compensated Flow Regulator regulates flow proportionally to the input solenoid current.
- A low cost valve designed to be used in applications where fine pressure compensation is not required.
- One piece cartridge housing ensures internal concentricity
- Coil: Waterproof, hermetically sealed, requires no O’Rings; Symmetrical coil can be reversed without affecting performance.
- Nonmagnetic spool and housing assembly
- Factory-adjusted low variation option (Model “L”) is available for applications where low variation of flow from valve to valve is essential at a given current or when an external pressure compensator is used.

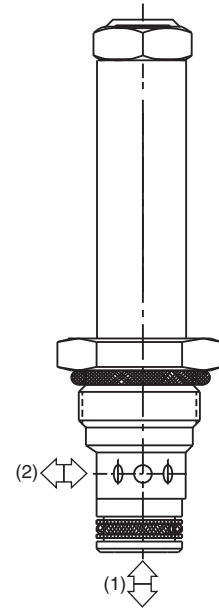
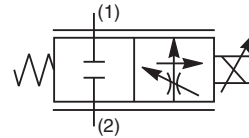

Specifications

Rated Flow 2 to 1 @ 210 Bar (3000 PSI)	Standard ('SS' Coil) 30 LPM (8 GPM) High Flow ('SP' Coil) 36 LPM (9.5 GPM)
Preferable Input Port For Best Hysteresis	Port 1
Hysteresis @ 100 Hz PWM	<10%
Cracking Pressure	21% of Rated Current (Standard) 17% of Rated Current (High Flow)
Variation of Flow @ 35% of Rated Current & Constant ΔP Maintained By Pressure Compensator	Standard Model Up To ±5% Of Rated Flow Model "L" ±2% Of Rated Flow
Cartridge Material	All parts steel. All operating parts hardened steel.
Operating Temp. Range/Seals	-34°C to +121°C (Nitrile) (-30°F to +250°F) -26°C to +204°C (Fluorocarbon) (-15°F to +400°F)
Fluid Compatibility/ Viscosity	Mineral-based or synthetic with lubricating properties at viscosities of 45 to 2000 SSU (6 to 420 cSt)
Filtration	ISO-4406 18/16/13, SAE Class 4
Approx. Weight	.12 kg (.26 lbs.)
Cavity	C10-2 (See BC Section for more details)

Performance Curves

▲ PWM Current Regulator Recommended

Flow vs. Input Current

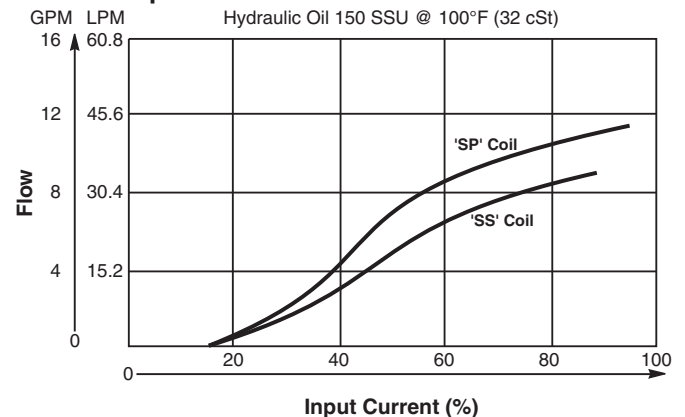

Flow Regulation

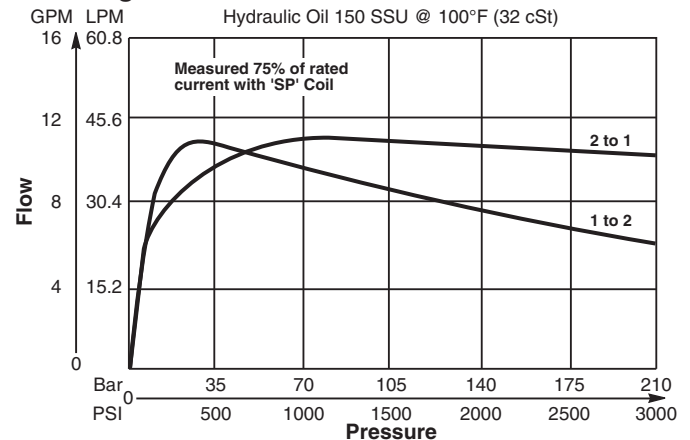

Dimensions Millimeters (Inches)

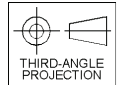
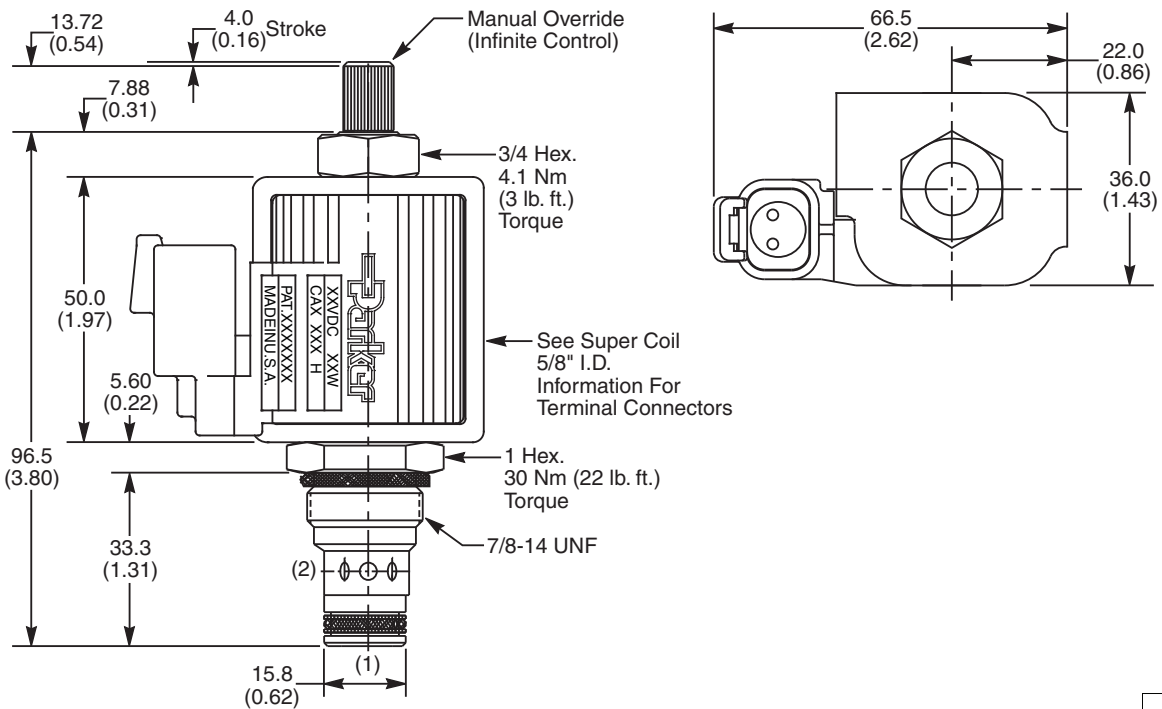

Ordering Information

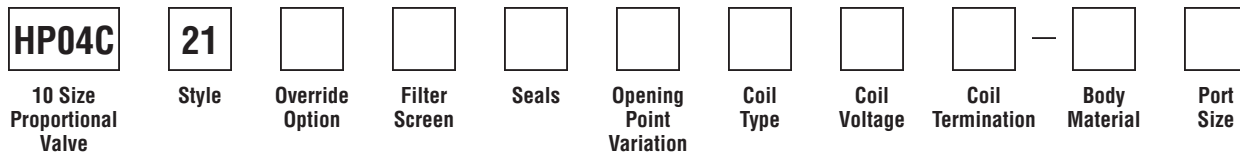

Code	Style (Maximum Regulated Flow)
21	Standard ('SS' Coil) 30 LPM (8 GPM)
21	High Flow ('SP' Coil) 36 LPM (9.5 GPM)

Code	Seals / Kit No.
N	Nitrile / Buna-N (Std.) (SK30503N-1)
V	Fluorocarbon / (SK30503V-1)

Code	Coil Voltage
Omit	Without Coil
D012	12 VDC
D024	24 VDC

Code	Body Material
Omit	Steel
A	Aluminum

Code	Override Option
0	Not Required
5	Infinite Control M.O.

Code	Flow Variation
Omit	Standard Up to ±5% of Current
L	Low Variation (±2% of Current Flow)

Code	Coil Termination
Omit	Without Coil
A	Amp Jr. Timer*
C	Conduit With Leads
D	DIN Plug Face
H	Molded Deutsch*
L	Dual Lead Wire*
PF	Packard Female*
PM	Packard Male*
S	Dual Spade*

Code	Port Size	Body Part No.
Omit	Cartridge Only	
6T	SAE-6	(B10-2-*6T)
8T	SAE-8	(B10-2-*8T)

* Add "A" for aluminum, omit for steel.

Code	Filter Screen
0	Not Available

Code	Coil Type
Omit	Without Coil
SS	Super Coil - 18 Watts
SP	Super Coil - 28 Watts

See Super Coil 5/8" I.D.
 *DC Only

- CV Check Valves
- SH Shuttle Valves
- LM Load/Motor Controls
- FC Flow Controls
- PC Pressure Controls
- LE Logic Elements
- DC Directional Controls
- MV Manual Valves
- SV Solenoid Valves
- PV Proportional Valves
- CE Coils & Electronics
- BC Bodies & Cavities
- TD Technical Data