

**Technical Information**

- CV** Check Valves
- SH** Shuttle Valves
- LM** Load/Motor Controls
- FC** Flow Controls
- PC** Pressure Controls
- LE** Logic Elements
- DC** Directional Controls
- MV** Manual Valves
- SV** Solenoid Valves
- PV** Proportional Valves
- CE** Coils & Electronics
- BC** Bodies & Cavities
- TD** Technical Data

**General Description**

Pilot Operated Sequence Valve (Externally Piloted, Internally Vented). For additional information see Technical Tips on pages PC1-PC6.

**Features**

- Hardened, precision ground parts for durability
- High accuracy, pilot operation design
- Ball-type pilot for added stability
- All external parts zinc plated

**Specifications**

<b>Rated Flow</b>	151.6 LPM (40 GPM)								
<b>Maximum Inlet Pressure</b>	380 Bar (5500 PSI)								
<b>Maximum Pressure Setting</b>	350 Bar (5000 PSI)								
<b>Sensitivity: Pressure/Turn</b>	<table border="0"> <tr> <td><b>10</b></td> <td>23 Bar (334 PSI)</td> </tr> <tr> <td><b>20</b></td> <td>37 Bar (539 PSI)</td> </tr> <tr> <td><b>30</b></td> <td>59.7 Bar (867 PSI)</td> </tr> <tr> <td><b>50</b></td> <td>118 Bar (1711 PSI)</td> </tr> </table>	<b>10</b>	23 Bar (334 PSI)	<b>20</b>	37 Bar (539 PSI)	<b>30</b>	59.7 Bar (867 PSI)	<b>50</b>	118 Bar (1711 PSI)
<b>10</b>	23 Bar (334 PSI)								
<b>20</b>	37 Bar (539 PSI)								
<b>30</b>	59.7 Bar (867 PSI)								
<b>50</b>	118 Bar (1711 PSI)								
<b>Maximum Tank Pressure</b>	350 Bar (5000 PSI)								
<b>Maximum Drain Flow</b>	See maximum drain flow chart (Lower right)								
<b>Reseat Pressure</b>	80% of Crack Pressure								
<b>Leakage at 150 SSU (32 cSt)</b>	82 cc/min. (5 cu. in./min.) @ 75% of Crack Pressure								
<b>Cartridge Material</b>	All parts steel. All operating parts hardened steel.								
<b>Operating Temp. Range/Seals</b>	-34°C to +121°C (Nitrile) (-30°F to +250°F) -26°C to +204°C (Fluorocarbon) (-15°F to +400°F)								
<b>Fluid Compatibility/Viscosity</b>	Mineral-based or synthetic with lubricating properties at viscosities of 45 to 2000 SSU (6 to 420 cSt)								
<b>Filtration</b>	ISO-4406 18/16/13, SAE Class 4								
<b>Approx. Weight</b>	.45 kg (1.0 lbs.)								
<b>Cavity</b>	C16-3 (See BC Section for more details)								
<b>Form Tool</b>	Rougher NFT16-3R Finisher NFT16-3F								

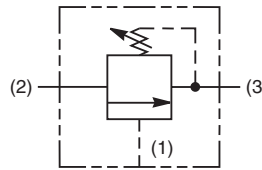
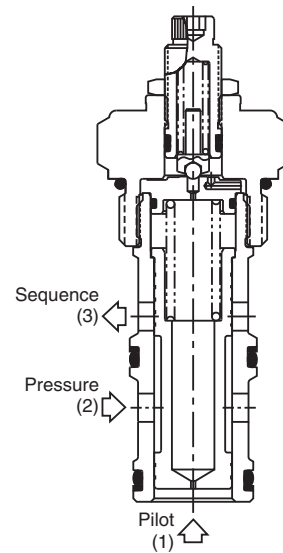

**Performance Curve**

**Flow vs. Inlet Pressure**

(Pressure rise through cartridge only)

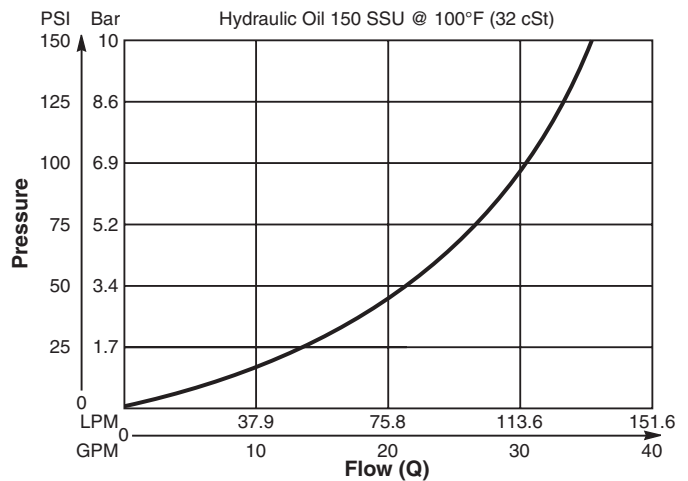

**Maximum Drain Flow**

<b>P<sub>PILOT</sub> - P<sub>SETTING</sub></b>	<b>Drain Flow</b>
6.9 Bar (100 PSI)	0.69 LPM (0.18 GPM)
35 Bar (500 PSI)	1.55 LPM (0.41 GPM)
69 Bar (1000 PSI)	2.19 LPM (0.58 GPM)
138 Bar (2000 PSI)	3.10 LPM (0.82 GPM)
207 Bar (3000 PSI)	3.79 LPM (1.00 GPM)

**Dimensions** Millimeters (Inches)

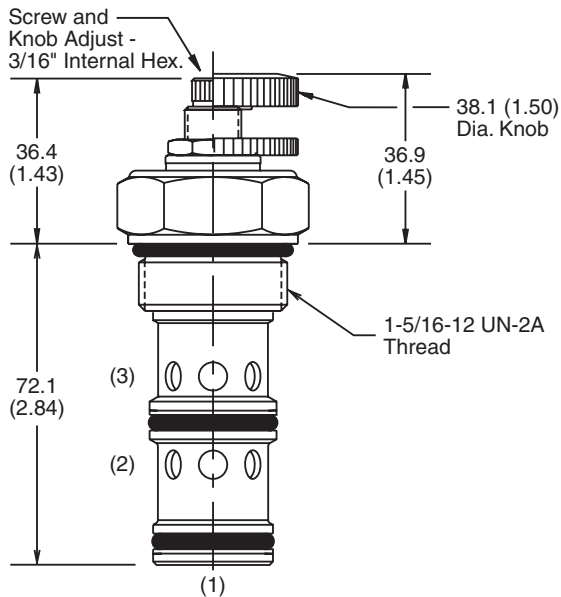

**Screw/Knob Version**

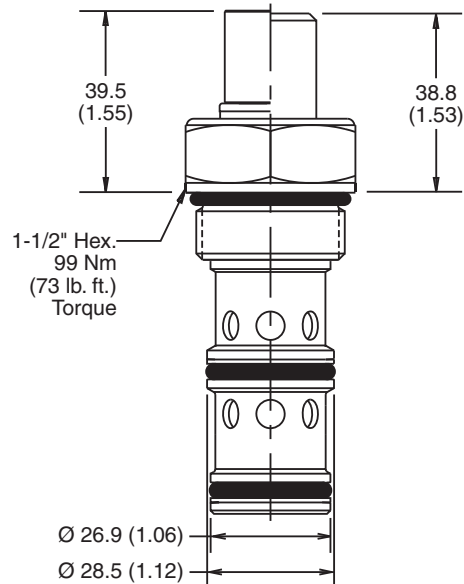

**Fixed Cap/Tamper Resistant Version**

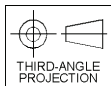

**Ordering Information**

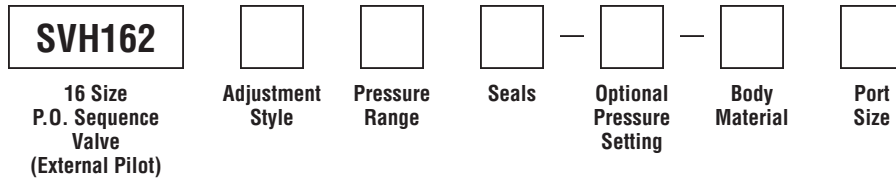

Code	Adjustment Style / Kit No.
F	Fixed style, preset at factory.
K	Knob Adjust (717784-15)
S	Screw Adjust
T	Tamper Resistant Cap (717785)

Code	Seals / Kit No.
Omit	Nitrile / (SK16-3)
V	Fluorocarbon / (SK16-3V)

Code	Body Material
Omit	Steel
A	Aluminum

Code	Pressure Range
10	6.9 - 69 Bar (100 - 1000 PSI) Standard Setting: 34.5 Bar (500 PSI) @ 11.3 LPM (3 GPM)
20	13.8 - 138 Bar (200 - 2000 PSI) Standard Setting: 69 Bar (1000 PSI) @ 11.3 LPM (3 GPM)
30	20.7 - 207 Bar (300 - 3000 PSI) Standard Setting: 103.5 Bar (1500 PSI) @ 11.3 LPM (3 GPM)
50	34.5 - 345 Bar (500 - 5000 PSI) Standard Setting: 172.4 Bar (2500 PSI) @ 11.3 LPM (3 GPM)

Optional Pressure Setting
Pressure ÷ 10 i.e. 235 = 2350 PSI (Omit if standard setting is used) Setting Range: 100 to 5000 PSI All settings at 11.3 LPM (3 GPM)

Code	Port Size	Body Part No.
Omit	Cartridge Only	
12T	SAE-12	(B16-3-*12T)
16T	SAE-16	(B16-3-*16T)

\* Add "A" for aluminum, omit for steel.

- CV**  
Check Valves
- SH**  
Shuttle Valves
- LM**  
Load/Motor Controls
- FC**  
Flow Controls
- PC**  
Pressure Controls
- LE**  
Logic Elements
- DC**  
Directional Controls
- MV**  
Manual Valves
- SV**  
Solenoid Valves
- PV**  
Proportional Valves
- CE**  
Coils & Electronics
- BC**  
Bodies & Cavities
- TD**  
Technical Data