

Technical Information

- CV** Check Valves
- SH** Shuttle Valves
- LM** Load/Motor Controls
- FC** Flow Controls
- PC** Pressure Controls
- LE** Logic Elements
- DC** Directional Controls
- MV** Manual Valves
- SV** Solenoid Valves
- PV** Proportional Valves
- CE** Coils & Electronics
- BC** Bore & Cavities
- TD** Technical Data

General Description

Direct Acting Pressure Reducing/Relieving Valve. For additional information see Technical Tips on pages PC1-PC6.



Note: The differential between system pressure and pressure setting of the valve can greatly affect the stability of this valve. For best performance, the inlet pressure setting should not exceed 69 Bar (1000 PSI) above the reducing valve setting.

Features

- Hardened, precision ground parts for durability
- Internal mechanical stop limits spool travel eliminating spring solidification
- “D”-Ring eliminates backup rings
- All external parts zinc plated

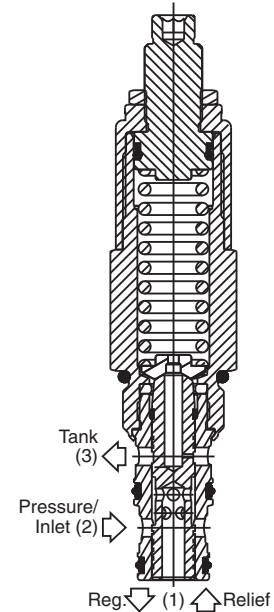
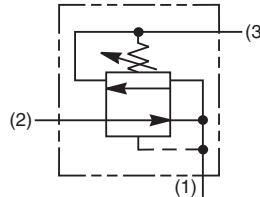

Specifications

Rated Flow	56 LPM (15 GPM)
Maximum Inlet Pressure	210 Bar (3000 PSI) 69 Bar (1000 PSI) maximum differential above valve setting for best stability
Maximum Pressure Setting	124 Bar (1800 PSI)
Sensitivity: Pressure/Turn	02 3.5 Bar (50 PSI) 06 6.6 Bar (95 PSI) 12 11.4 Bar (165 PSI) 21 17.2 Bar (250 PSI)
Maximum Tank Pressure	124 Bar (1800 PSI)
Maximum Drain Flow	120 ml/min. (0.03 GPM)
Cartridge Material	All parts steel. All operating parts hardened steel.
Operating Temp. Range/Seals	-45°C to +132°C (“D”-Ring) (-50°F to +270°F) -34°C to +121°C (Nitrile) (-30°F to +250°F) -26°C to +204°C (Fluorocarbon) (-15°F to +400°F)
Fluid Compatibility/Viscosity	Mineral-based or synthetic with lubricating properties at viscosities of 45 to 2000 SSU (6 to 420 cSt)
Filtration	ISO-4406 18/16/13, SAE Class 4
Approx. Weight	.23 kg (0.5 lbs.)
Cavity	C10-3 (See BC Section for more details)
Form Tool	Rougher NTF10-3R Finisher NFT10-3F

Performance Curves

(Pressure rise through cartridge only)

Flow vs. Regulated Pressure

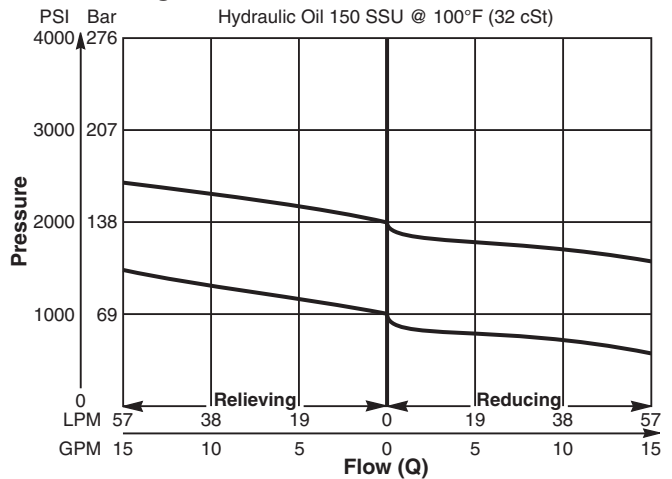

Pressure vs. Flow

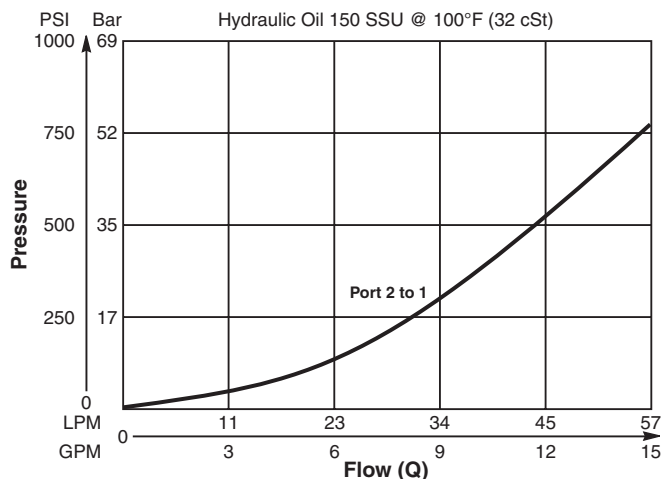

Dimensions Millimeters (Inches)

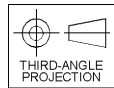
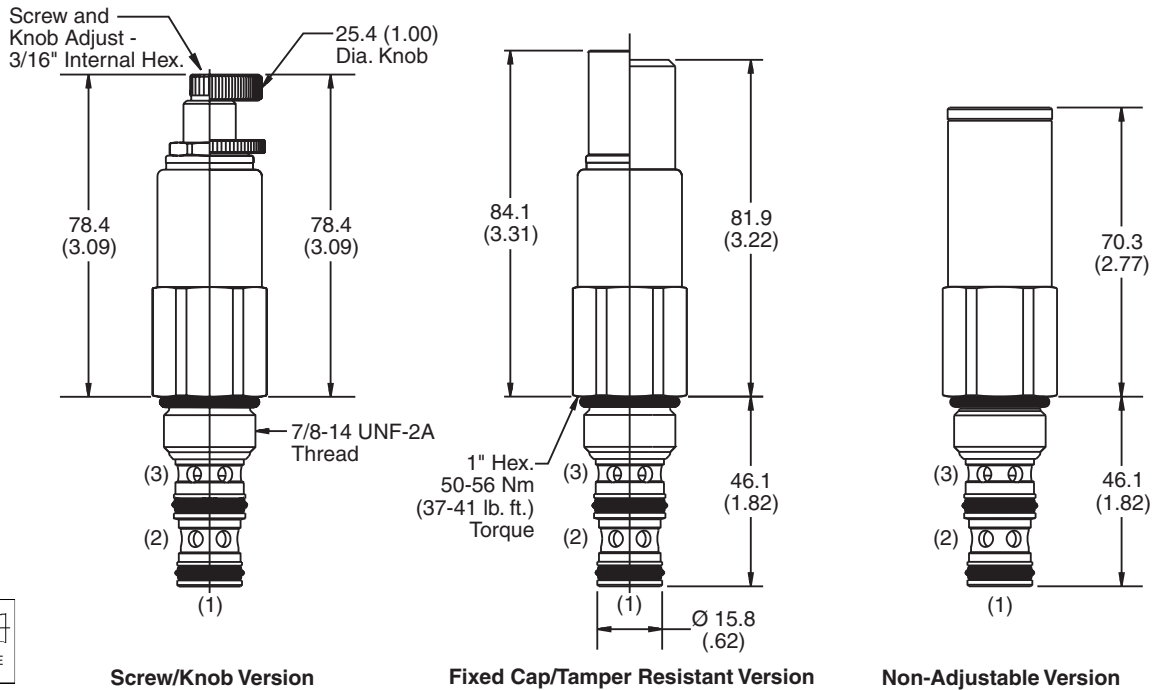

Screw/Knob Version

Fixed Cap/Tamper Resistant Version

Non-Adjustable Version

Ordering Information

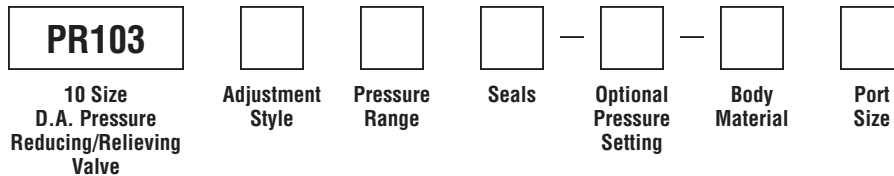

Code	Adjustment Style / Kit No.
F	Fixed style, preset at factory.
K	Knob Adjust (717784-10)
N	Non-Adjustable
S	Screw Adjust
T	Tamper Resistant Cap (717943)

Code	Seals / Kit No.
Omit	"D"-Ring / (SK10-3)
N	Nitrile / (SK10-3N)
V	Fluorocarbon / (SK10-3V)

Code	Body Material
Omit	Steel
A	Aluminum

Optional Pressure Setting	
Pressure ÷ 10	i.e. 150 = 1500 PSI
(Omit if standard setting is used)	
Setting Range:	50 to 2100 PSI
All settings at .95 LPM (.25 GPM)	

Code	Port Size	Body Part No.
Omit	Cartridge Only	
6T	SAE-6	(B10-3-*6T)
8T	SAE-8	(B10-3-*8T)

* Add "A" for aluminum, omit for steel.

Code	Pressure Range
02	5.2 - 13.8 Bar (75 - 200 PSI) Standard Setting: 6.9 Bar (100 PSI) @ .95 LPM (.25 GPM)
06	17.2 - 41.4 Bar (250 - 600 PSI) Standard Setting: 20.7 Bar (300 PSI) @ .95 LPM (.25 GPM)
12	39.3 - 83 Bar (570 - 1200 PSI) Standard Setting: 41.4 Bar (600 PSI) @ .95 LPM (.25 GPM)
21	41.4 - 124.1 Bar (600 - 1800 PSI) Standard Setting: 69 Bar (1000 PSI) @ .95 LPM (.25 GPM)



- CV**
Check Valves
- SH**
Shuttle Valves
- LM**
Load/Motor Controls
- FC**
Flow Controls
- PC**
Pressure Controls
- LE**
Logic Elements
- DC**
Directional Controls
- MV**
Manual Valves
- SV**
Solenoid Valves
- PV**
Proportional Valves
- CE**
Coils & Electronics
- BC**
Bodies & Cavities
- TD**
Technical Data