



Air-Driven, High Flow, High Pressure Liquid Pumps

Technical & Performance Data Sheet Digest

Manual: 02-9277BE | February 2022



ENGINEERING YOUR SUCCESS.

Parker Instrumentation Products Division (IPD)

Live Chat Support is available from www.parker.com/IPD when the Chat icon “” is visible on screen.

Table of Contents

Page

ASL Pumps (Single-Acting, Single and Dual Piston Air Drive)

ASL10-01	4
ASL25-01	8
ASL35-01	12
ASL35-02	16
ASL60-01	20
ASL60-02	24
ASL100-01	28
ASL100-02	32
ASL150-01	36
ASL150-02	40
ASL250-01	44
ASL400-01	48
ASL400-02	52

ACHL Pumps (Single-Acting, Single Piston Air Drive with Hand Lever)

ACHL72-01	57
ACHL189-01	61

AHL Pumps (Double-Acting, Dual Piston Air Drive)

AHL33-2D	66
AHL66-2D	70
AHL118-2D	74

AFL Pumps (Double-Acting, Single Ended Piston Air Drive)

AFL35-1D	79
AFL60-1D	83
AFL100-1D	87

Available Pump Accessories

- Relief Valve / Safety Head
- Complete line of High Pressure Components - Valves, Fittings, Tubing
- Spare Parts



FAILURE, IMPROPER SELECTION OR IMPROPER USE OF THE PRODUCTS AND/OR SYSTEMS DESCRIBED HEREIN OR RELATED ITEMS CAN CAUSE DEATH, PERSONAL INJURY AND PROPERTY DAMAGE.

This document and other information from Parker Hannifin Corporation, its subsidiaries and authorized distributors provide product and/or system options for further investigation by users having technical expertise. It is important that you analyze all aspects of your application and review the information concerning the product or system in the current product catalog.

Due to the variety of operating conditions and applications for these products or systems, the user, through its own analysis and testing, is solely responsible for making the final selection of the products and systems and assuring that all performance, safety and warning requirements of the application are met.

The products described herein, including without limitation, product features, specifications, designs, availability and pricing, are subject to change by Parker Hannifin Corporation and its subsidiaries at any time without notice.

ALL PARKER VALVES MUST PASS A RIGID OPERATIONAL AND LEAKAGE TEST BEFORE LEAVING THE FACTORY. IT IS RECOMMENDED AFTER ANY REASSEMBLY, THE VALVE SHOULD BE TESTED BY THE USER FOR OPERATION AND LEAKAGE. IF THESE INSTRUCTIONS ARE NOT FULLY COMPLIED WITH, THE REPAIRED PRODUCT MAY FAIL AND CAUSE DAMAGE TO PROPERTY OR INJURY TO PERSONS. PARKER HANNIFIN CANNOT ASSUME RESPONSIBILITY FOR PERFORMANCE OF A CUSTOMER SERVICED VALVE.

Series ASL



Series ASL10-01 (Single-Acting, Single Piston Air Drive)

Air-Driven, High Flow, High Pressure Liquid Pump

Technical & Performance Data Sheet

Manual: 02-9244BE | January 2022



ENGINEERING YOUR SUCCESS.

Technical Data

Section 1.0 Liquid Side Specifications

Service: Oil, Water or Water/Oil mixture and other fluids depending on material compatibility

Maximum Outlet Pressure: 1,600 psi (110 bar)

Air to Liquid Pressure Ratio: 1:11

Volume Displacement Per Stroke: 5.22 in³ (85.5 cm³)

Inlet Connection: 1" FNPT

Outlet Connection: 1/2" FNPT Female NPT

Section 2.0 Air Side Specifications

Air Drive Pressure Range: 15-150 psi (1-10 bar)* **(Note)**

Nominal Air Pressure Required: 1,600 psi (110 bar)

Output Pressure: 145 psi (10 bar)

Inlet Port: 1/2" FNPT

Pilot Port: 1/8" FNPT (unregulated air)

Exhaust Port (muffler removed): 1/2" FNPT

Air Consumption @ 90 psi: 69 SCFM

Prelubricated at Factory

***Note:** Maximum air drive pressure is limited by maximum output pressure.

Section 3.0 General Specifications

Maximum Operating Temperature: 0-140° F (-18° to 60° C)

Net Weight: 38 lbs. (17.2 kg)

Pressure Head: 15-5 PH Stainless Steel

Plunger Description: Stainless steel plunger utilizing a proprietary multi-layer carbon based coating with diamond like carbon exterior layer - 3 times the hardness of stellite with a coefficient of friction equal to/less than PTFE

Check Valve Glands: 316 Stainless Steel

Liquid Seal: UHMWPE U-Cup and FKM O-Rings

Air Drive Seals: Buna N



General Information

Section 4.0 - Ordering Guide

For complete information on available pump options, contact Parker Autoclave Engineers.

Typical catalog number: **ASL10-01SNPV**

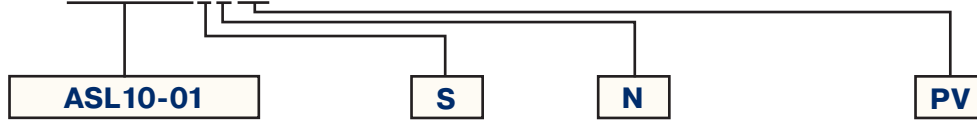

Pump Type / Size / Ratio

- ASL** =
- Standard Liquid High Flow, High Pressure Pump
 - 6" Single Piston Air Drive
 - 1:11 Air-to-Liquid Pressure Ratio
 - Maximum 1,600 psi (110 bar)

Liquid Inlet Location

* **S** = Side

Isolation Chamber

* **N** = None

Liquid Seal Materials†

PV = UHMWPE U-Cup and FKM O-Rings

Section 5.0 - Flow Rate vs. Outlet Pressure

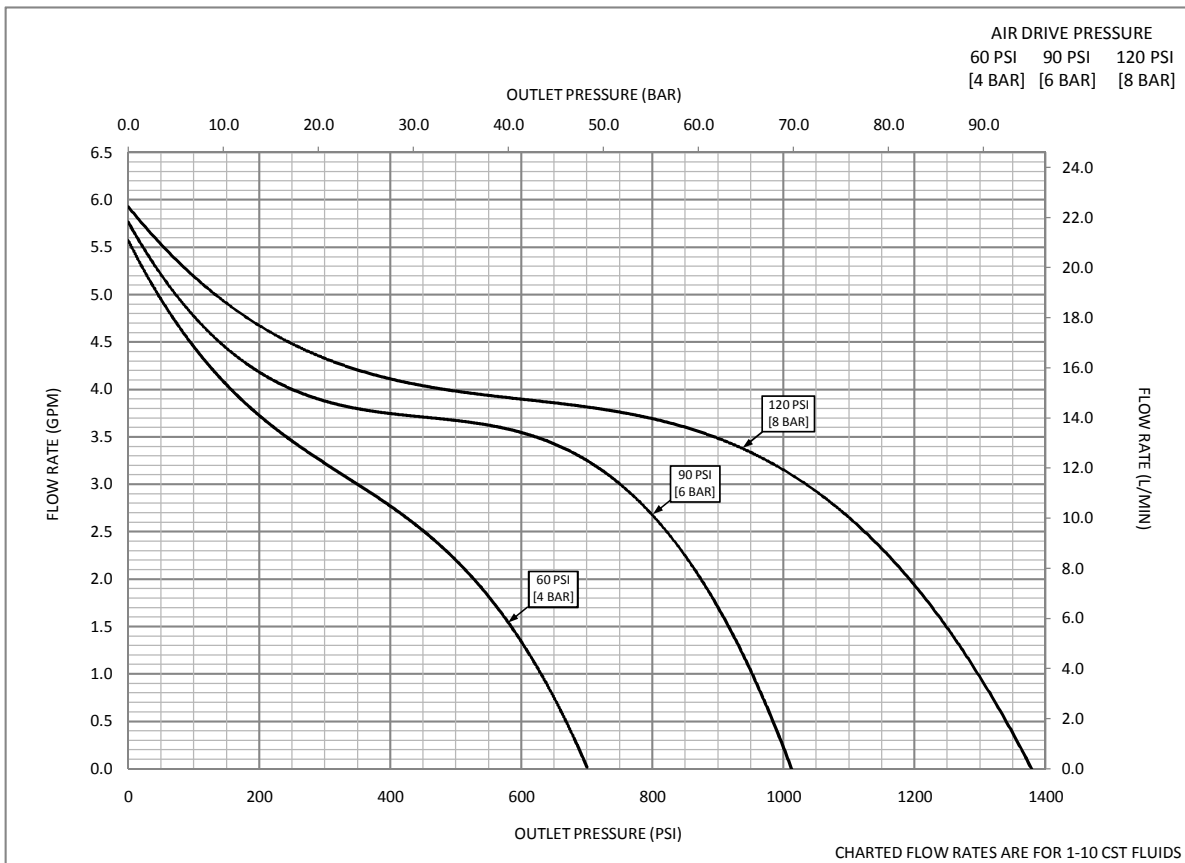

Actual flow rates will vary depending on air flow capacity, downstream flow restrictions, and fluid type.



General Information

Section 6.0 - Dimensional Data

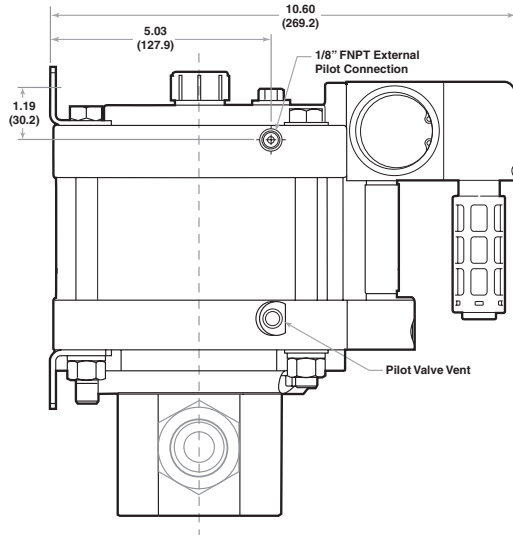

Left View

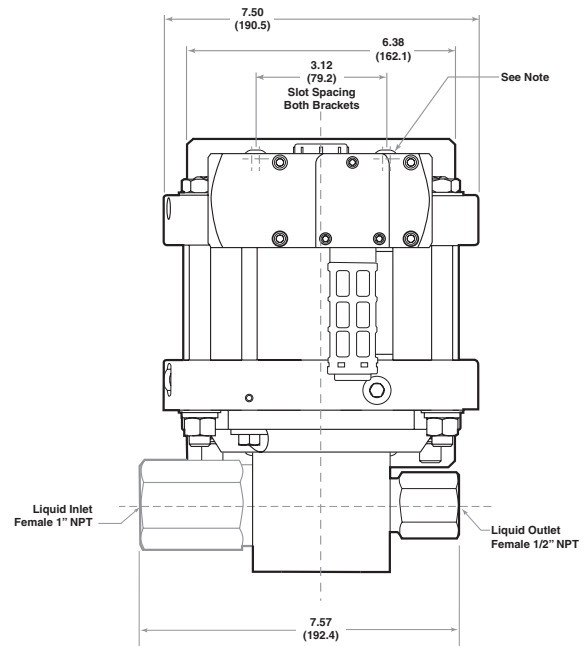

Front View

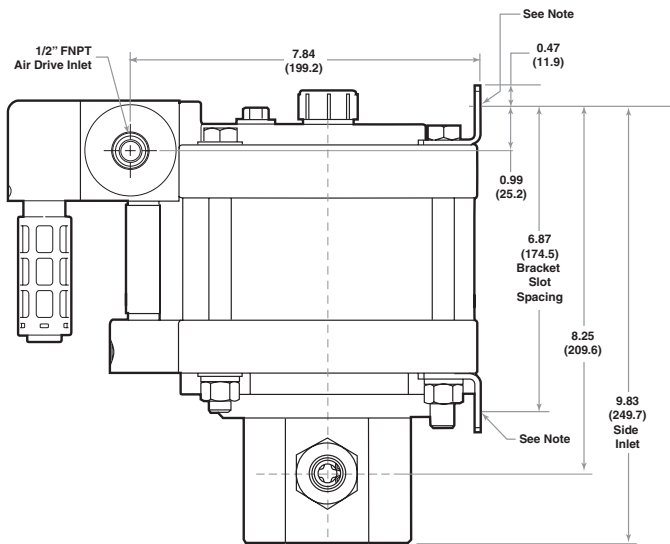

Right View

Note:

Each Mounting Bracket includes (2) x 13/32" (10.32) Slots for 3/8" Bolts.

All dimensions are for reference only and are subject to change without notice.

Primary Dimensions: Inches

Secondary Dimensions: (Millimeters)





Series ASL25-01 (Single-Acting, Single Piston Air Drive)

Air-Driven, High Flow, High Pressure Liquid Pump

Technical & Performance Data Sheet

Manual: 02-9251BE | January 2022



ENGINEERING YOUR SUCCESS.

Technical Data

Section 1.0 Liquid Side Specifications

Service: Oil, Water or Water/Oil mixture and other fluids depending on material compatibility

Maximum Outlet Pressure: 4,000 psi (276 bar)

Air to Liquid Pressure Ratio: 1:28

Volume Displacement Per Stroke: 2.10 in³ (34.4 cm³)

Inlet Connection: 1/2" FNPT

Outlet Connection: 1/2" FNPT Female NPT

Section 2.0 Air Side Specifications

Air Drive Pressure Range: 15-150 psi (1-10 bar)* **(Note)**

Nominal Air Pressure Required: 4,000 psi (276 bar)

Output Pressure: 143 psi (9.9 bar)

Inlet Port: 1/2" FNPT

Pilot Port: 1/8" FNPT (unregulated air)

Exhaust Port (muffler removed): 1/2" FNPT

Air Consumption @ 90 psi: 69 SCFM

Prelubricated at Factory

***Note:** Maximum air drive pressure is limited by maximum output pressure.

Section 3.0 General Specifications

Maximum Operating Temperature: 0-140° F (-18° to 60° C)

Net Weight: 38 lbs. (17.2 kg)

Pressure Head: 15-5 PH Stainless Steel

Plunger Description: Stainless steel plunger utilizing a proprietary multi-layer carbon based coating with diamond like carbon exterior layer - 3 times the hardness of stellite with a coefficient of friction equal to/less than PTFE

Check Valve Glands: 316 Stainless Steel

Liquid Seal: UHMWPE U-Cup and FKM O-Rings

Air Drive Seals: Buna N



General Information

Section 4.0 - Ordering Guide

For complete information on available pump options, contact Parker Autoclave Engineers.

Typical catalog number: **ASL25-01SNPV**

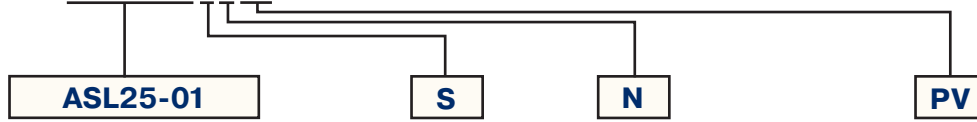

Pump Type / Size / Ratio

- ASL** =
- Standard Liquid High Flow, High Pressure Pump
 - 6" Single Piston Air Drive
 - 1:28 Air-to-Liquid Pressure Ratio
 - Maximum 4,000 psi (276 bar)

Liquid Inlet Location

* **S** = Side

Isolation Chamber

* **N** = None

Liquid Seal Materials†

PV = UHMWPE U-Cup and FKM O-Rings

Section 5.0 - Flow Rate vs. Outlet Pressure

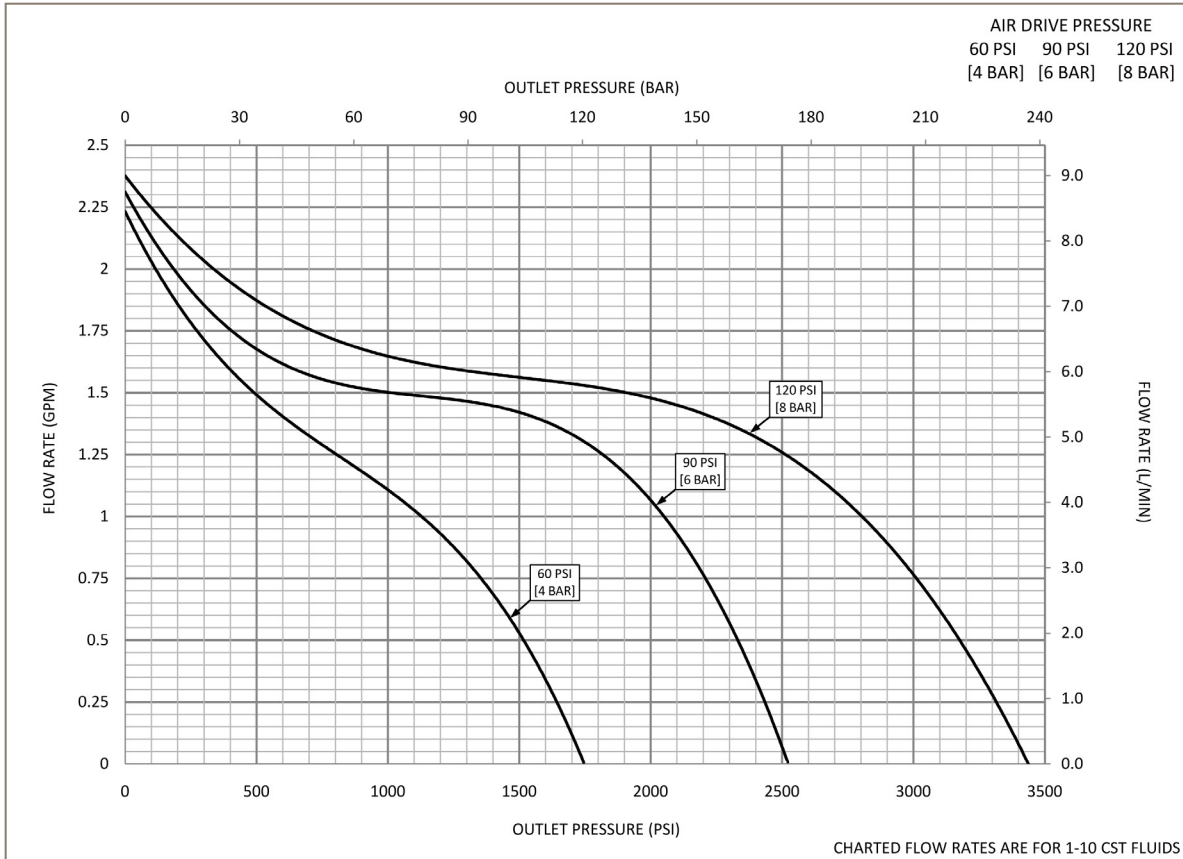

Actual flow rates will vary depending on air flow capacity, downstream flow restrictions, and fluid type.



General Information

Section 6.0 - Dimensional Data

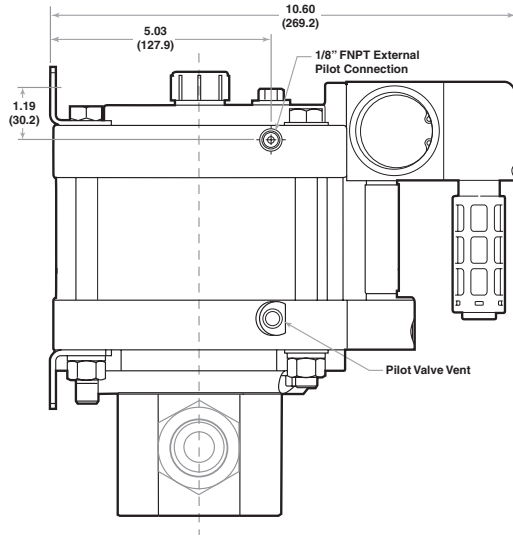

Left View

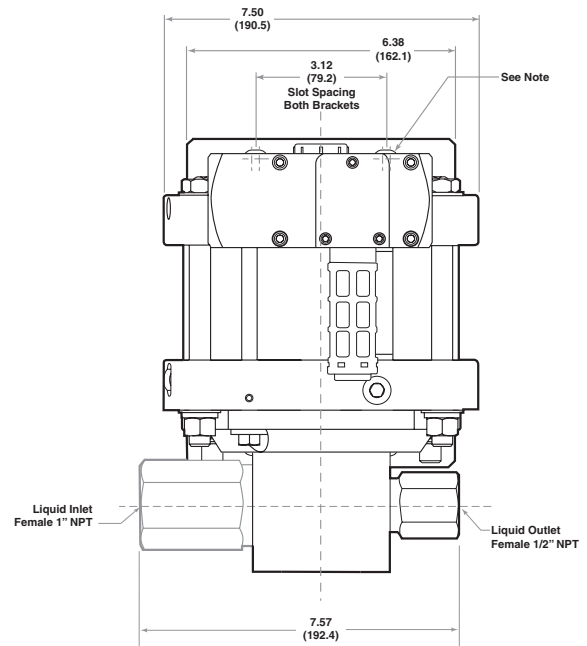

Front View

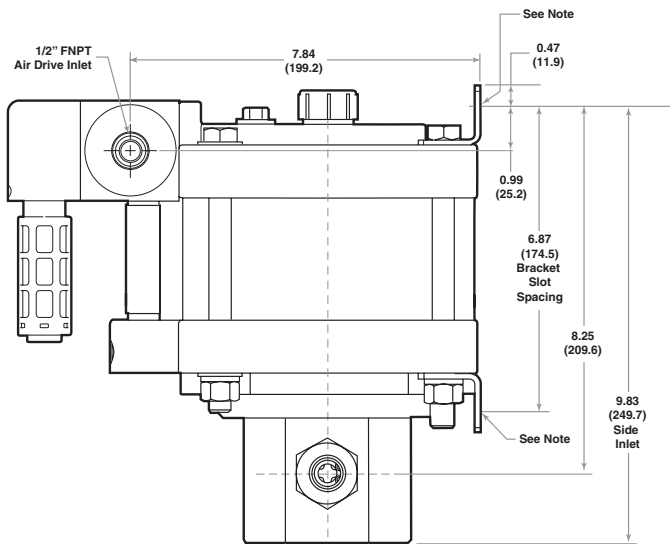

Right View

Note:

Each Mounting Bracket includes (2) x 13/32" (10.32) Slots for 3/8" Bolts.

All dimensions are for reference only and are subject to change without notice.

Primary Dimensions: Inches

Secondary Dimensions: (Millimeters)





Series ASL35-01 (Single-Acting, Single Piston Air Drive)

Air-Driven, High Flow, High Pressure Liquid Pump

Technical & Performance Data Sheet

Manual: 02-9257BE | January 2022



ENGINEERING YOUR SUCCESS.

Technical Data

Section 1.0 Liquid Side Specifications

Service: Oil, Water or Water/Oil mixture and other fluids depending on material compatibility

Maximum Outlet Pressure: 5,600 psi (386 bar)

Air to Liquid Pressure Ratio: 1:39

Volume Displacement Per Stroke: 1.50 in³ (24.6 cm³)

Inlet Connection: 1/2" FNPT

Outlet Connection: 1/2" FNPT Female NPT

Section 2.0 Air Side Specifications

Air Drive Pressure Range: 15-150 psi (1-10 bar)* **(Note)**

Nominal Air Pressure Required: 5,600 psi (386 bar)

Output Pressure: 143 psi (9.9 bar)

Inlet Port: 1/2" FNPT

Pilot Port: 1/8" FNPT (unregulated air)

Exhaust Port (muffler removed): 1/2" FNPT

Air Consumption @ 90 psi: 63 SCFM

Prelubricated at Factory

***Note:** Maximum air drive pressure is limited by maximum output pressure.

Section 3.0 General Specifications

Maximum Operating Temperature: 0-140° F (-18° to 60° C)

Net Weight: 38 lbs. (17.2 kg)

Pressure Head: 15-5 PH Stainless Steel

Plunger Description: Stainless steel plunger utilizing a proprietary multi-layer carbon based coating with diamond like carbon exterior layer - 3 times the hardness of stellite with a coefficient of friction equal to/less than PTFE

Check Valve Glands: 316 Stainless Steel

Liquid Seal: UHMWPE U-Cup and FKM O-Rings

Air Drive Seals: Buna N



General Information

Section 4.0 - Ordering Guide

For complete information on available pump options, contact Parker Autoclave Engineers.

Typical catalog number: **ASL35-01SNPV**

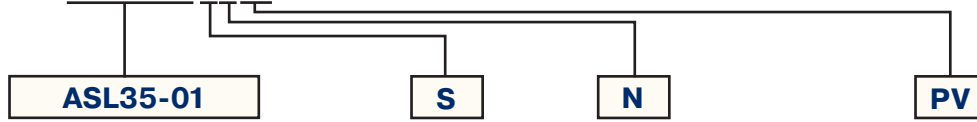

Pump Type / Size / Ratio	Liquid Inlet Location	Isolation Chamber	Liquid Seal Materials†
ASL = <ul style="list-style-type: none"> • Standard Liquid High Flow, High Pressure Pump • 6" Single Piston Air Drive • 1:39 Air-to-Liquid Pressure Ratio • Maximum 5,600 psi (386 bar) 	* S = Side	* N = None	PV = UHMWPE U-Cup and FKM O-Rings

Section 5.0 - Flow Rate vs. Outlet Pressure

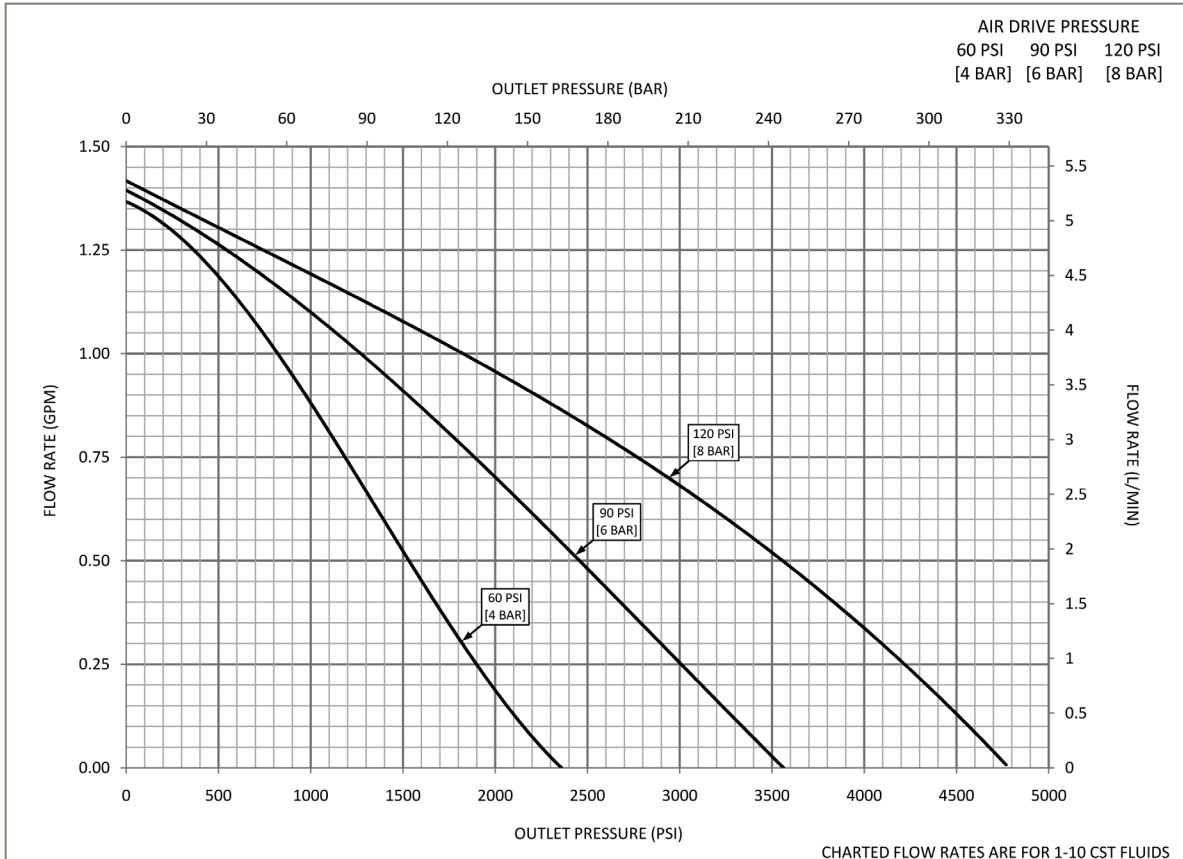

Actual flow rates will vary depending on air flow capacity, downstream flow restrictions, and fluid type.



General Information

Section 6.0 - Dimensional Data

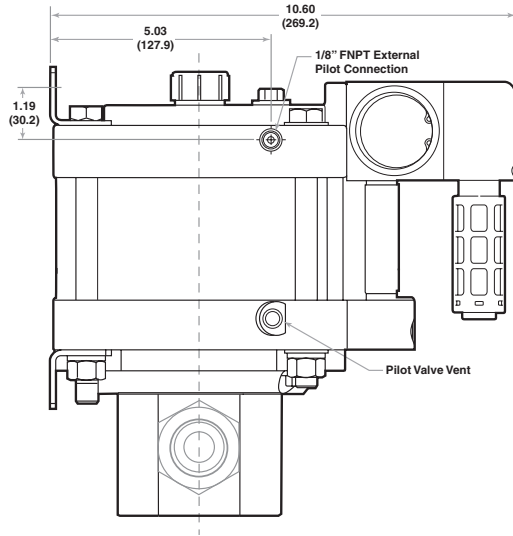

Left View

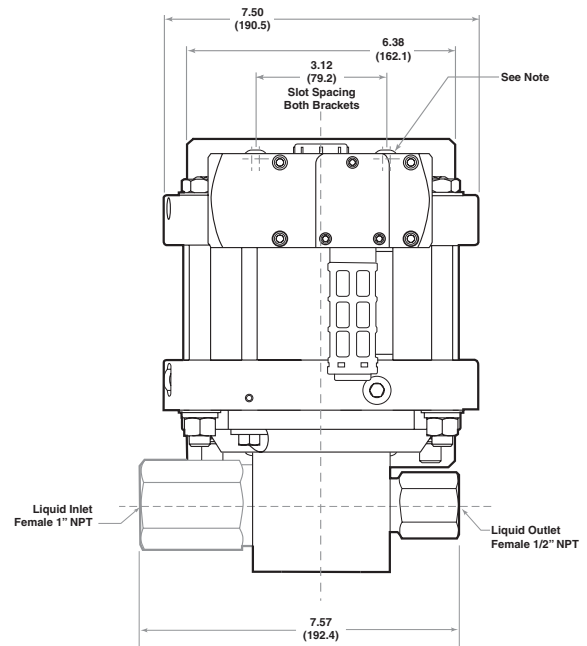

Front View

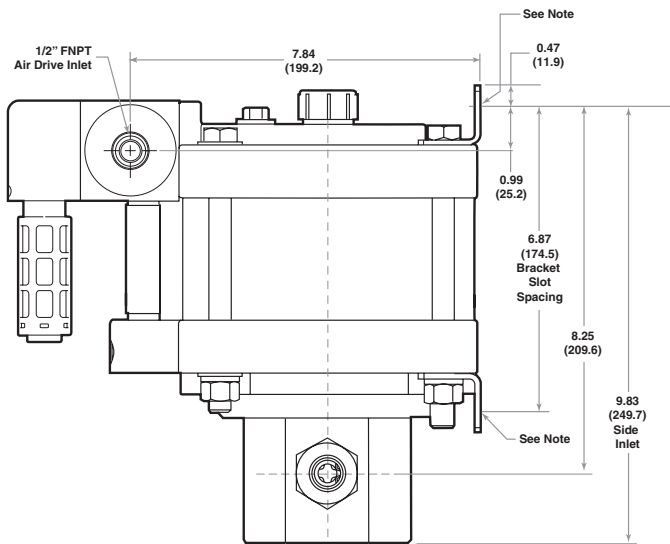

Right View

Note:

Each Mounting Bracket includes (2) x 13/32" (10.32) Slots for 3/8" Bolts.

All dimensions are for reference only and are subject to change without notice.

Primary Dimensions: Inches

Secondary Dimensions: (Millimeters)





Series ASL35-02 (Single-Acting, Dual Piston Air Drive)

Air-Driven, High Flow, High Pressure Liquid Pump

Technical & Performance Data Sheet

Manual: 02-9262BE | February 2022



ENGINEERING YOUR SUCCESS.

Technical Data

Section 1.0 Liquid Side Specifications

Service: Oil, Water or Water/Oil mixture and other fluids depending on material compatibility

Maximum Outlet Pressure: 11,200 psi (772 bar)

Air to Liquid Pressure Ratio: 1:78

Volume Displacement Per Stroke: 1.50 in³ (24.6 cm³)

Inlet Connection: 1/2" FNPT

Outlet Connection: 1/2" FNPT Female NPT

Section 2.0 Air Side Specifications

Air Drive Pressure Range: 15-150 psi (1-10 bar)* **(Note)**

Nominal Air Pressure Required: 11,200 psi (772 bar)

Output Pressure: 143 psi (9.9 bar)

Inlet Port: 1/2" FNPT

Pilot Port: 1/8" FNPT (unregulated air)

Exhaust Port (muffler removed): 1/2" FNPT

Air Consumption @ 90 psi: 56 SCFM

Prelubricated at Factory

***Note:** Maximum air drive pressure is limited by maximum output pressure.

Section 3.0 General Specifications

Maximum Operating Temperature: 0-140° F (-18° to 60° C)

Net Weight: 46 lbs. (20.9 kg)

Pressure Head: 15-5 PH Stainless Steel

Plunger Description: Stainless steel plunger utilizing a proprietary multi-layer carbon based coating with diamond like carbon exterior layer - 3 times the hardness of stellite with a coefficient of friction equal to/less than PTFE

Check Valve Glands: 316 Stainless Steel

Liquid Seal: UHMWPE U-Cup and FKM O-Rings

Air Drive Seals: Buna N



General Information

Section 4.0 - Ordering Guide

For complete information on available pump options, contact Parker Autoclave Engineers.

Typical catalog number: **ASL35-02SNPV**

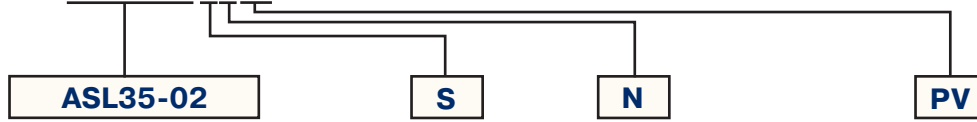

Pump Type / Size / Ratio	Liquid Inlet Location	Isolation Chamber	Liquid Seal Materials†
ASL = <ul style="list-style-type: none"> • Standard Liquid High Flow, High Pressure Pump • 6" Dual Piston Air Drive • 1:78 Air-to-Liquid Pressure Ratio • Maximum 11,200 psi (772 bar) 	* S = Side	* N = None	PV = UHMWPE U-Cup and FKM O-Rings

Section 5.0 - Flow Rate vs. Outlet Pressure

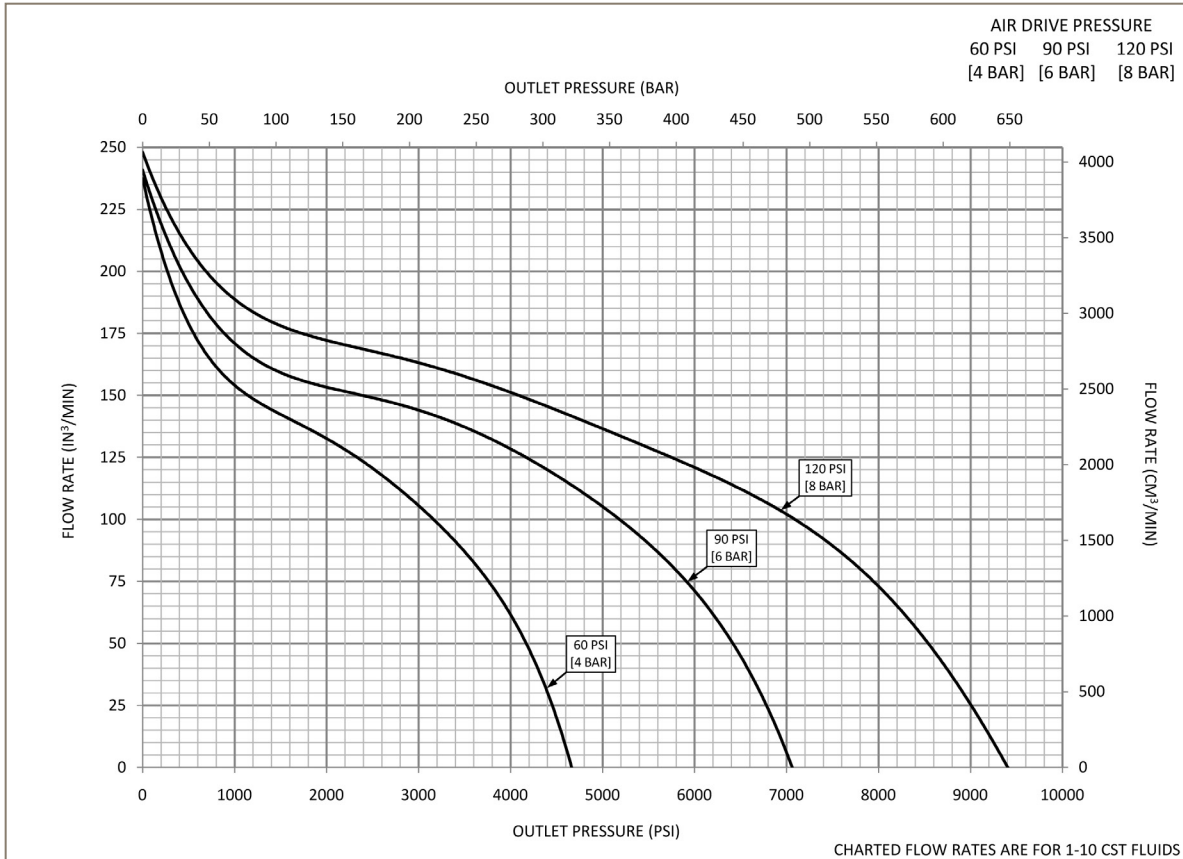

Actual flow rates will vary depending on air flow capacity, downstream flow restrictions, and fluid type.



General Information

Section 6.0 - Dimensional Data

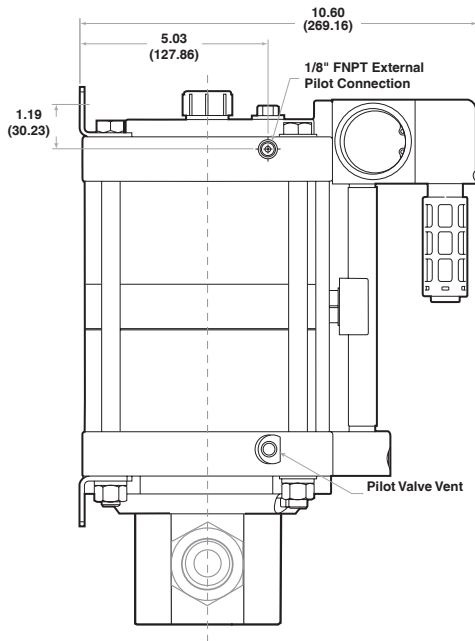

Left View

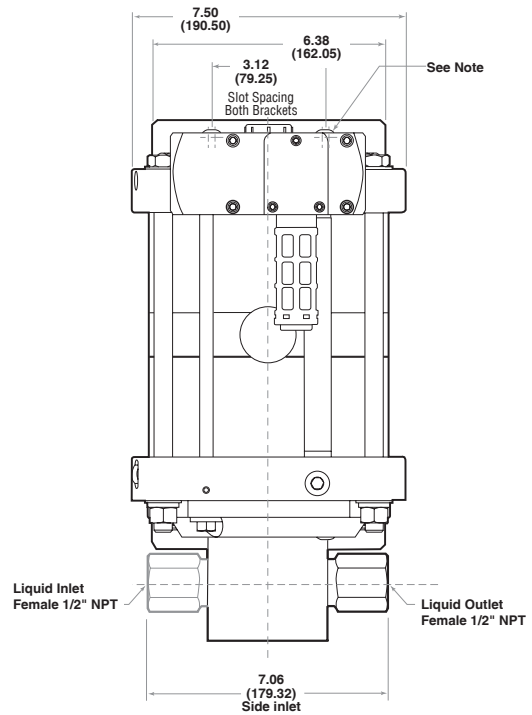

Front View

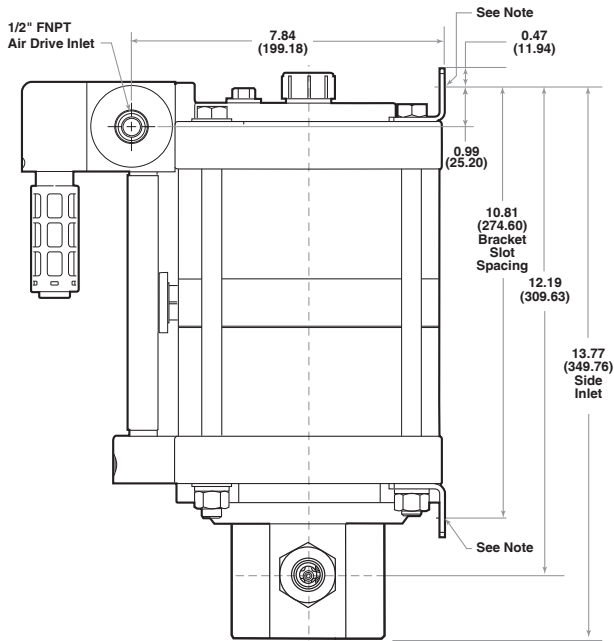

Right View

Note:

Each Mounting Bracket includes (2) x 13/32" (10.32) Slots for 3/8" Bolts.

All dimensions are for reference only and are subject to change without notice.

Primary Dimensions: Inches

Secondary Dimensions: (Millimeters)





Series ASL60-01 (Single-Acting, Single Piston Air Drive)

Air-Driven, High Flow, High Pressure Liquid Pump

Technical & Performance Data Sheet

Manual: 02-9252BE | January 2022



ENGINEERING YOUR SUCCESS.

Technical Data

Section 1.0 Liquid Side Specifications

Service: Oil, Water or Water/Oil mixture and other fluids depending on material compatibility

Maximum Outlet Pressure: 10,000 psi (690 bar)

Air to Liquid Pressure Ratio: 1:70

Volume Displacement Per Stroke: 0.84 in³ (13.7 cm³)

Inlet Connection: 1/2" FNPT

Outlet Connection: 1/2" FNPT Female NPT

Section 2.0 Air Side Specifications

Air Drive Pressure Range: 15-150 psi (1-10 bar)* **(Note)**

Nominal Air Pressure Required: 10,000 psi (690 bar)

Output Pressure: 143 psi (9.9 bar)

Inlet Port: 1/2" FNPT

Pilot Port: 1/8" FNPT (unregulated air)

Exhaust Port (muffler removed): 1/2" FNPT

Air Consumption @ 90 psi: 64 SCFM

Prelubricated at Factory

***Note:** Maximum air drive pressure is limited by maximum output pressure.

Section 3.0 General Specifications

Maximum Operating Temperature: 0-140° F (-18° to 60° C)

Net Weight: 32 lbs. (14.5 kg)

Pressure Head: 15-5 PH Stainless Steel

Plunger Description: Stainless steel plunger utilizing a proprietary multi-layer carbon based coating with diamond like carbon exterior layer - 3 times the hardness of stellite with a coefficient of friction equal to/less than PTFE

Check Valve Glands: 316 Stainless Steel

Liquid Seal: UHMWPE U-Cup and FKM O-Rings

Air Drive Seals: Buna N



General Information

Section 4.0 - Ordering Guide

For complete information on available pump options, contact Parker Autoclave Engineers.

Typical catalog number: **ASL60-01SNP**

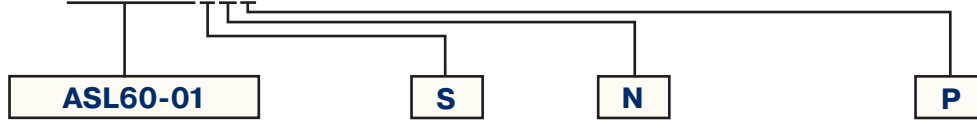

Pump Type / Size / Ratio	Liquid Inlet Location	Isolation Chamber	Liquid Seal Materials†
ASL = <ul style="list-style-type: none"> • Standard Liquid High Flow, High Pressure Pump • 6" Single Piston Air Drive • 1:70 Air-to-Liquid Pressure Ratio • Maximum 10,000 psi (690 bar) 	* S = Side	* N = None	P = UHMWPE U-Cup with Elgiloy Spring Energizer

Section 5.0 - Flow Rate vs. Outlet Pressure

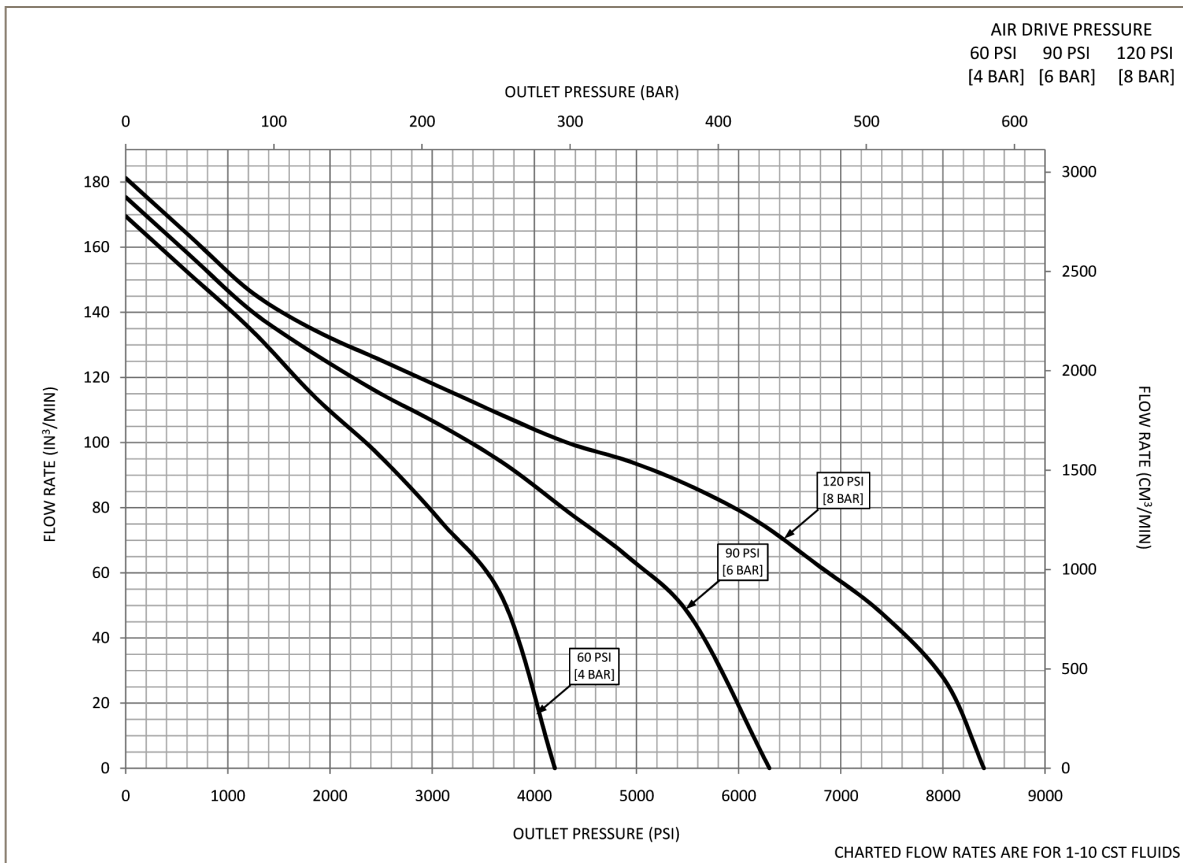

Actual flow rates will vary depending on air flow capacity, downstream flow restrictions, and fluid type.



General Information

Section 6.0 - Dimensional Data

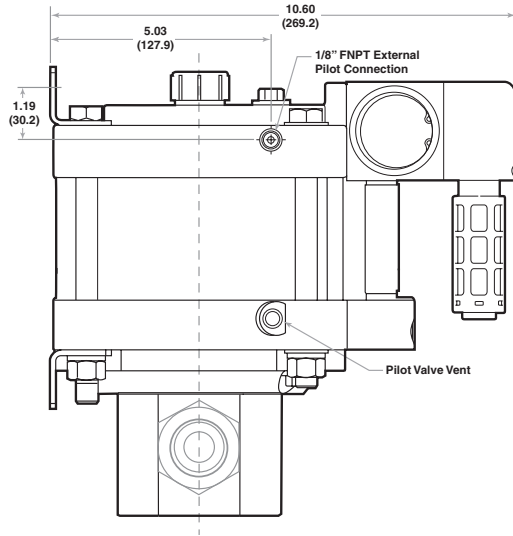

Left View

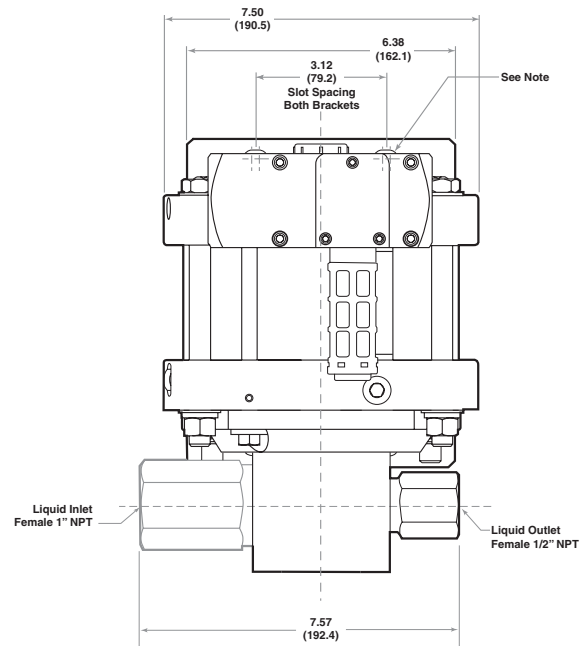

Front View

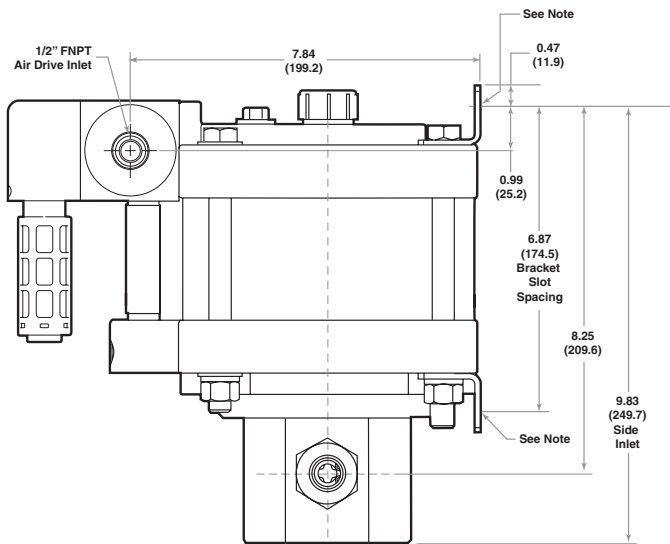

Right View

Note:

Each Mounting Bracket includes (2) x 13/32" (10.32) Slots for 3/8" Bolts.

All dimensions are for reference only and are subject to change without notice.

Primary Dimensions: Inches

Secondary Dimensions: (Millimeters)





Series ASL60-02 (Single-Acting, Dual Piston Air Drive)

Air-Driven, High Flow, High Pressure Liquid Pump

Technical & Performance Data Sheet

Manual: 02-9264BE | February 2022



ENGINEERING YOUR SUCCESS.

Technical Data

Section 1.0 Liquid Side Specifications

Service: Oil, Water or Water/Oil mixture and other fluids depending on material compatibility

Maximum Outlet Pressure: 20,000 psi (1379 bar)

Air to Liquid Pressure Ratio: 1:140

Volume Displacement Per Stroke: 0.84 in³ (13.8 cm³)

Inlet Connection: 1/2" FNPT

Outlet Connection: Parker Autoclave SF562CX20-9/16" Female Medium Pressure

Section 2.0 Air Side Specifications

Air Drive Pressure Range: 15-150 psi (1-10 bar)* **(Note)**

Nominal Air Pressure Required: 20,000 psi (1379 bar)

Output Pressure: 143 psi (9.9 bar)

Inlet Port: 1/2" FNPT

Pilot Port: 1/8" FNPT (unregulated air)

Exhaust Port (muffler removed): 1/2" FNPT

Air Consumption @ 90 psi: 59 SCFM

Prelubricated at Factory

***Note:** Maximum air drive pressure is limited by maximum output pressure.

Section 3.0 General Specifications

Maximum Operating Temperature: 0-140° F (-18° to 60° C)

Net Weight: 43 lbs. (19.5 kg)

Pressure Head: 15-5 PH Stainless Steel

Plunger Description: Stainless steel plunger utilizing a proprietary multi-layer carbon based coating with diamond like carbon exterior layer - 3 times the hardness of stellite with a coefficient of friction equal to/less than PTFE

Check Valve Glands: 316 Stainless Steel (SS)

Liquid Seal: UHMWPE U-Cup with SS Spring Energizer

Air Drive Seals: Buna N



General Information

Section 4.0 - Ordering Guide

For complete information on available pump options, contact Parker Autoclave Engineers.

Typical catalog number: **ASL60-02SNPV**

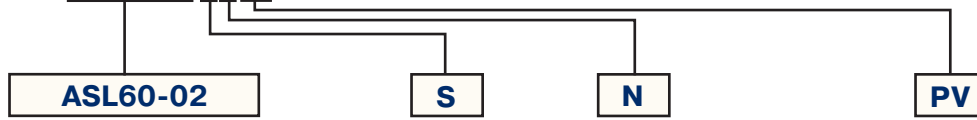

Pump Type / Size / Ratio	Liquid Inlet Location	Isolation Chamber	Liquid Seal Materials†
ASL = <ul style="list-style-type: none"> • Standard Liquid High Flow, High Pressure Pump • 6" Dual Piston Air Drive • 1:140 Air-to-Liquid Pressure Ratio • Maximum 20,000 psi (1379 bar) 	* S = Side	* N = None	PV = UHMWPE U-Cup with Elgiloy Spring Energizer

Section 5.0 - Flow Rate vs. Outlet Pressure

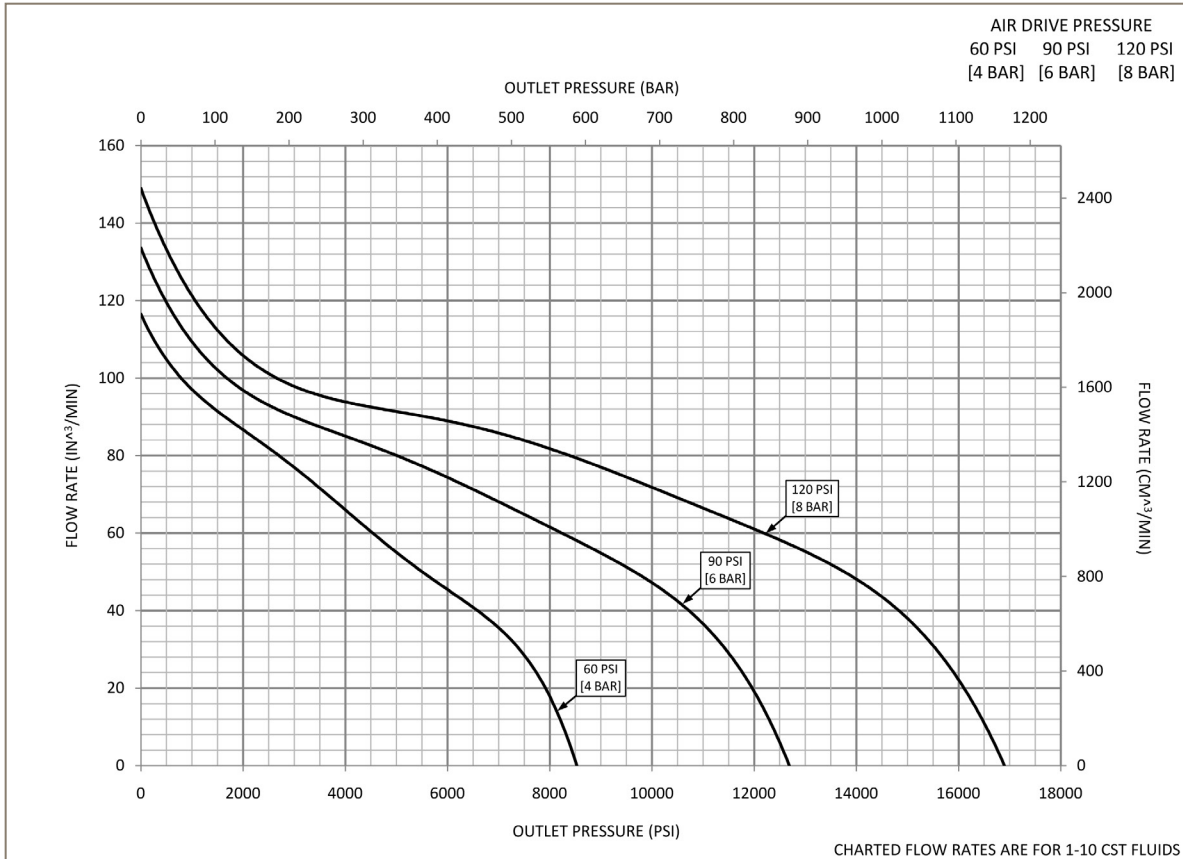

Actual flow rates will vary depending on air flow capacity, downstream flow restrictions, and fluid type.



General Information

Section 6.0 - Dimensional Data

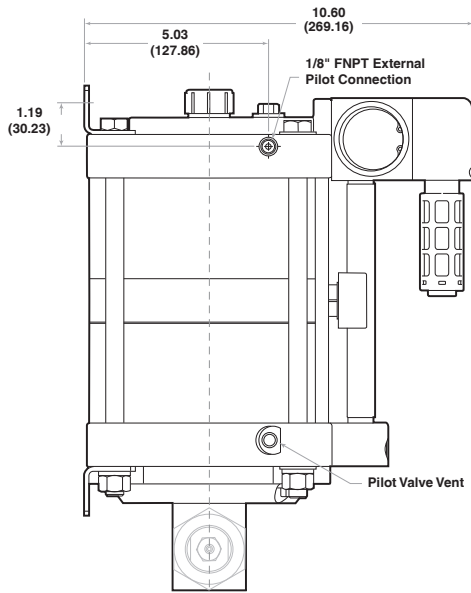

Left View

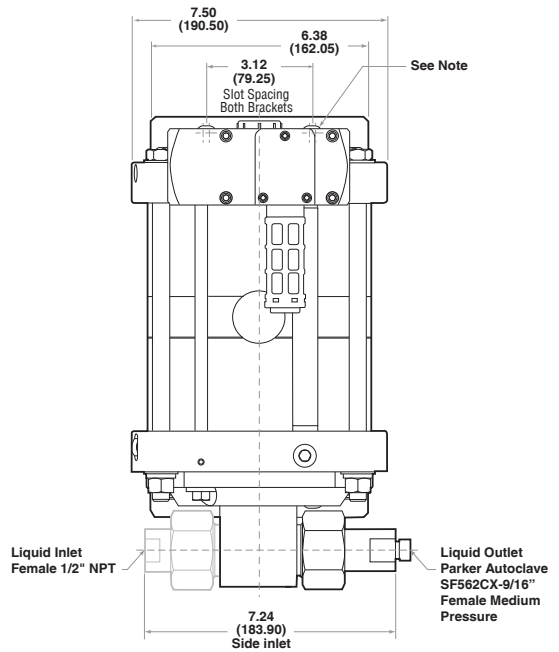

Front View

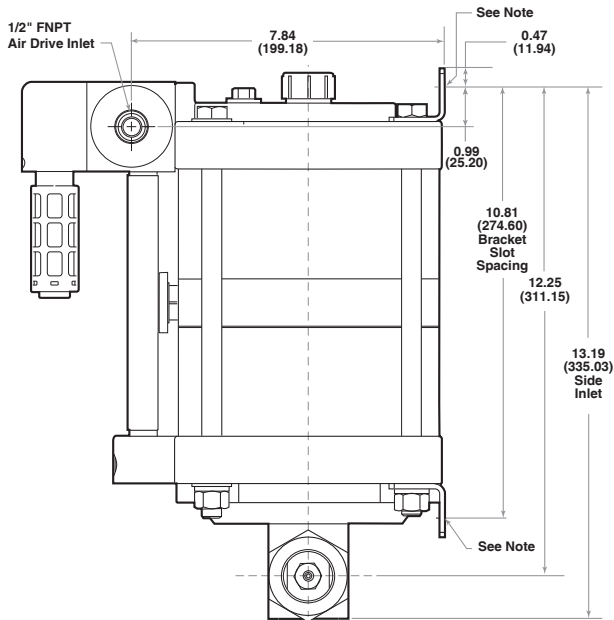

Right View

Note:

Each Mounting Bracket includes (2) x 13/32" (10.32) Slots for 3/8" Bolts.

All dimensions are for reference only and are subject to change without notice.

Primary Dimensions: Inches

Secondary Dimensions: (Millimeters)



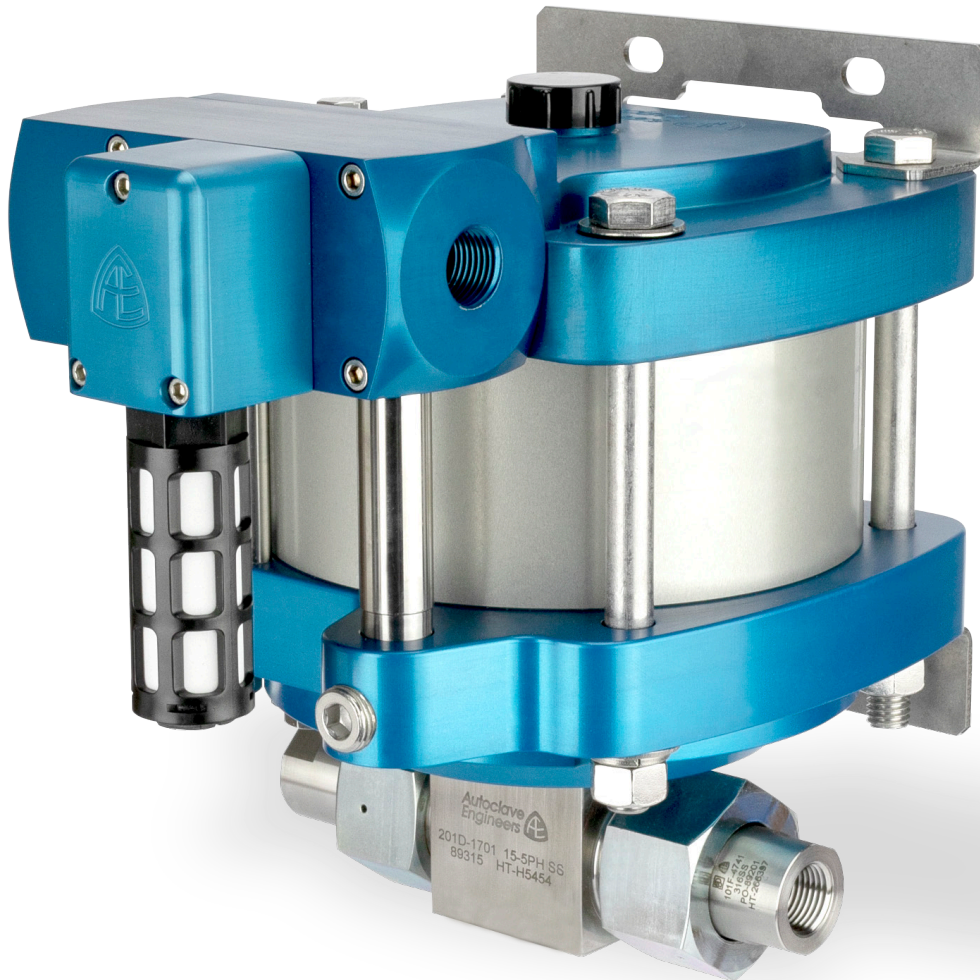

Series ASL100-01 (Single-Acting, Single Piston Air Drive)

Air-Driven, High Flow, High Pressure Liquid Pump

Technical & Performance Data Sheet

Manual: 02-9253BE | January 2022



ENGINEERING YOUR SUCCESS.

Technical Data

Section 1.0 Liquid Side Specifications

Service: Oil, Water or Water/Oil mixture and other fluids depending on material compatibility

Maximum Outlet Pressure: 15,000 psi (1034 bar)

Air to Liquid Pressure Ratio: 1:113

Volume Displacement Per Stroke: 0.52 in³ (8.5 cm³)

Inlet Connection: 1/2" FNPT

Outlet Connection: 1/2" FNPT

Section 2.0 Air Side Specifications

Air Drive Pressure Range: 15-150 psi (1-10 bar)* **(Note)**

Nominal Air Pressure Required: 15,000 psi (1034 bar)

Output Pressure: 133 psi (9.9 bar)

Inlet Port: 1/2" FNPT

Pilot Port: 1/8" FNPT (unregulated air)

Exhaust Port (muffler removed): 1/2" FNPT

Air Consumption @ 90 psi: 64 SCFM

Prelubricated at Factory

***Note:** Maximum air drive pressure is limited by maximum output pressure.

Section 3.0 General Specifications

Maximum Operating Temperature: 0-140° F (-18° to 60° C)

Net Weight: 32 lbs. (14.5 kg)

Pressure Head: 15-5 PH Stainless Steel

Plunger Description: Stainless steel plunger utilizing a proprietary multi-layer carbon based coating with diamond like carbon exterior layer - 3 times the hardness of stellite with a coefficient of friction equal to/less than PTFE

Check Valve Glands: 316 Stainless Steel (SS)

Liquid Seal: UHMWPE U-Cup with SS Spring Energizer

Air Drive Seals: Buna N



General Information

Section 4.0 - Ordering Guide

For complete information on available pump options, contact Parker Autoclave Engineers.

Typical catalog number: **ASL100-01SNP**

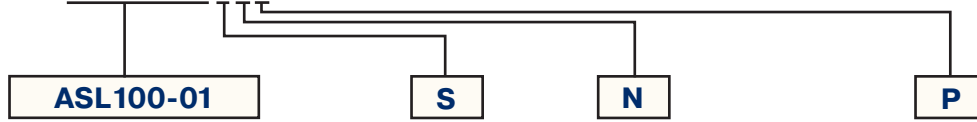

Pump Type / Size / Ratio	Liquid Inlet Location	Isolation Chamber	Liquid Seal Materials†
ASL = <ul style="list-style-type: none"> • Standard Liquid High Flow, High Pressure Pump • 6" Single Piston Air Drive • 1:113 Air-to-Liquid Pressure Ratio • Maximum 15,000 psi (1034 bar) 	* S = Side	* N = None	P = UHMWPE U-Cup with Stainless Steel Spring Energizer

Section 5.0 - Flow Rate vs. Outlet Pressure

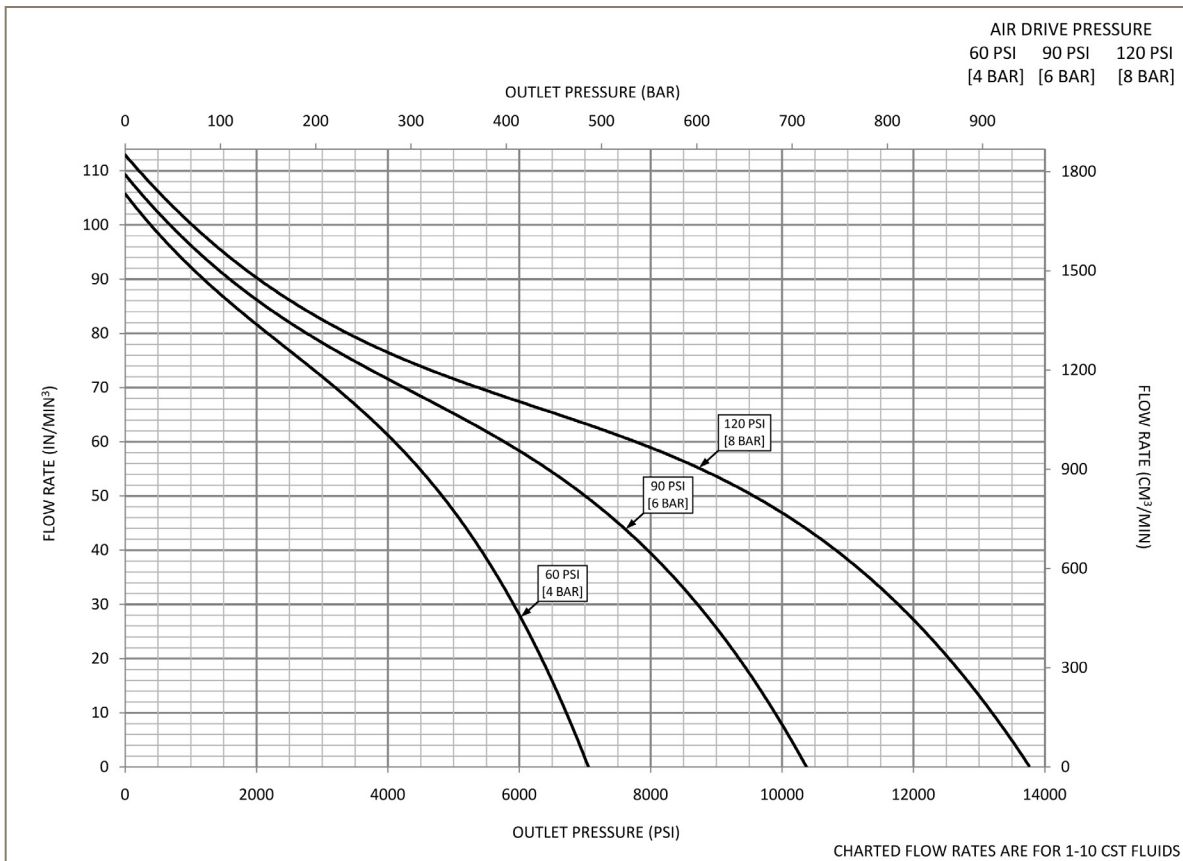

Actual flow rates will vary depending on air flow capacity, downstream flow restrictions, and fluid type.



General Information

Section 6.0 - Dimensional Data

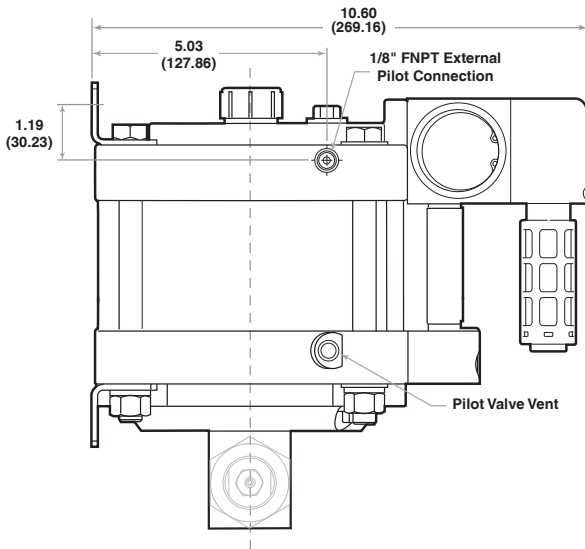

Left View

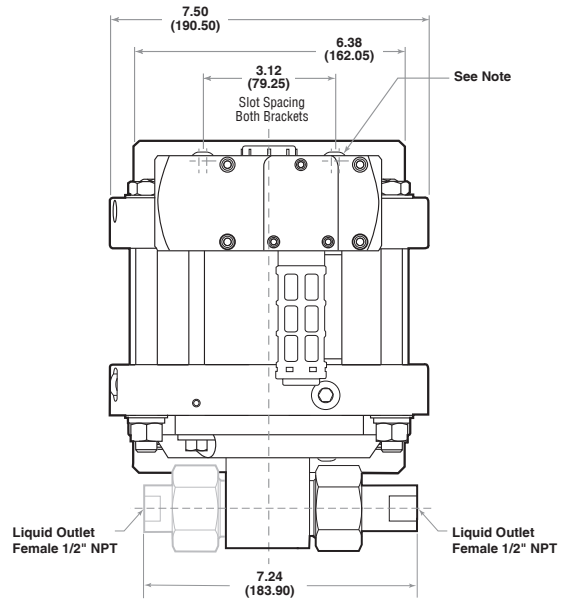

Front View

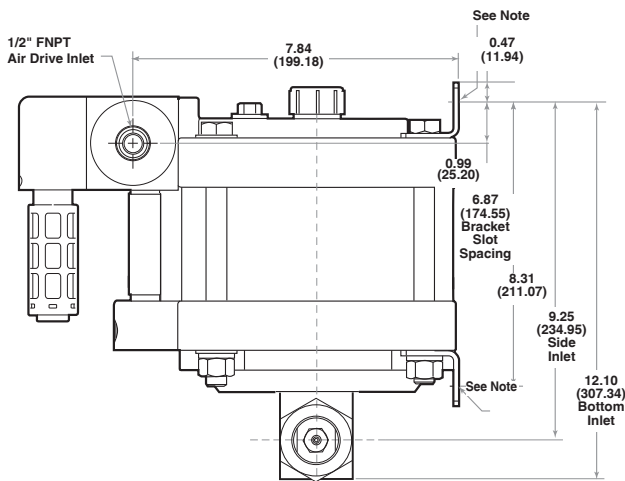

Right View

Note:

Each Mounting Bracket includes (2) x 13/32" (10.32) Slots for 3/8" Bolts.

All dimensions are for reference only and are subject to change without notice.

Primary Dimensions: Inches

Secondary Dimensions: (Millimeters)





Series ASL100-02 (Single-Acting, Dual Piston Air Drive)

Air-Driven, High Flow, High Pressure Liquid Pump

Technical & Performance Data Sheet

Manual: 02-9230BE | February 2022



ENGINEERING YOUR SUCCESS.

Technical Data

Section 1.0 Liquid Side Specifications

Service: Oil, Water or Water/Oil mixture and other fluids depending on material compatibility

Maximum Outlet Pressure: 31,000 psi (2137 bar)

Air to Liquid Pressure Ratio: 1:226

Volume Displacement Per Stroke: 0.52 in³ (8.5 cm³)

Inlet Connection: 1/2" FNPT

Outlet Connection: Parker Autoclave F250C-1/4" Female High Pressure

Section 2.0 Air Side Specifications

Air Drive Pressure Range: 15-150 psi (1-10 bar)* **(Note)**

Nominal Air Pressure Required: 31,000 psi (2137 bar)

Output Pressure: 137 psi (9.5 bar)

Inlet Port: 1/2" FNPT

Pilot Port: 1/8" FNPT (unregulated air)

Exhaust Port (muffler removed): 1/2" FNPT

Air Consumption @ 90 psi: 59 SCFM

Prelubricated at Factory

***Note:** Maximum air drive pressure is limited by maximum output pressure.

Section 3.0 General Specifications

Maximum Operating Temperature: 0-140° F (-18° to 60° C)

Net Weight: 42 lbs. (19.1 kg)

Pressure Head: 15-5 PH Stainless Steel

Plunger Description: Stainless steel plunger utilizing a proprietary multi-layer carbon based coating with diamond like carbon exterior layer - 3 times the hardness of stellite with a coefficient of friction equal to/less than PTFE

Check Valve Glands: 316 Stainless Steel (SS)

Liquid Seal: UHMWPE U-Cup with SS Spring Energizer

Air Drive Seals: Buna N



General Information

Section 4.0 - Ordering Guide

For complete information on available pump options, contact Parker Autoclave Engineers.

Typical catalog number: **ASL100-02SNP**

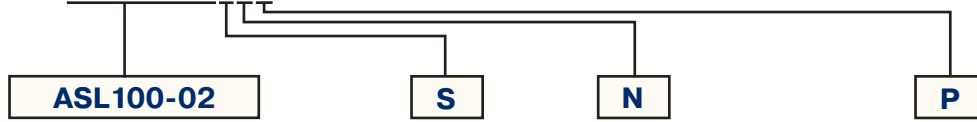

Pump Type / Size / Ratio	Liquid Inlet Location	Isolation Chamber	Liquid Seal Materials†
ASL = <ul style="list-style-type: none"> Standard Liquid High Flow, High Pressure Pump 6" Dual Piston Air Drive 1:226 Air-to-Liquid Pressure Ratio Maximum 31,000 psi (2137 bar) 	* S = Side	* N = None	P = UHMWPE U-Cup with Stainless Steel Spring Energizer

Section 5.0 - Flow Rate vs. Outlet Pressure

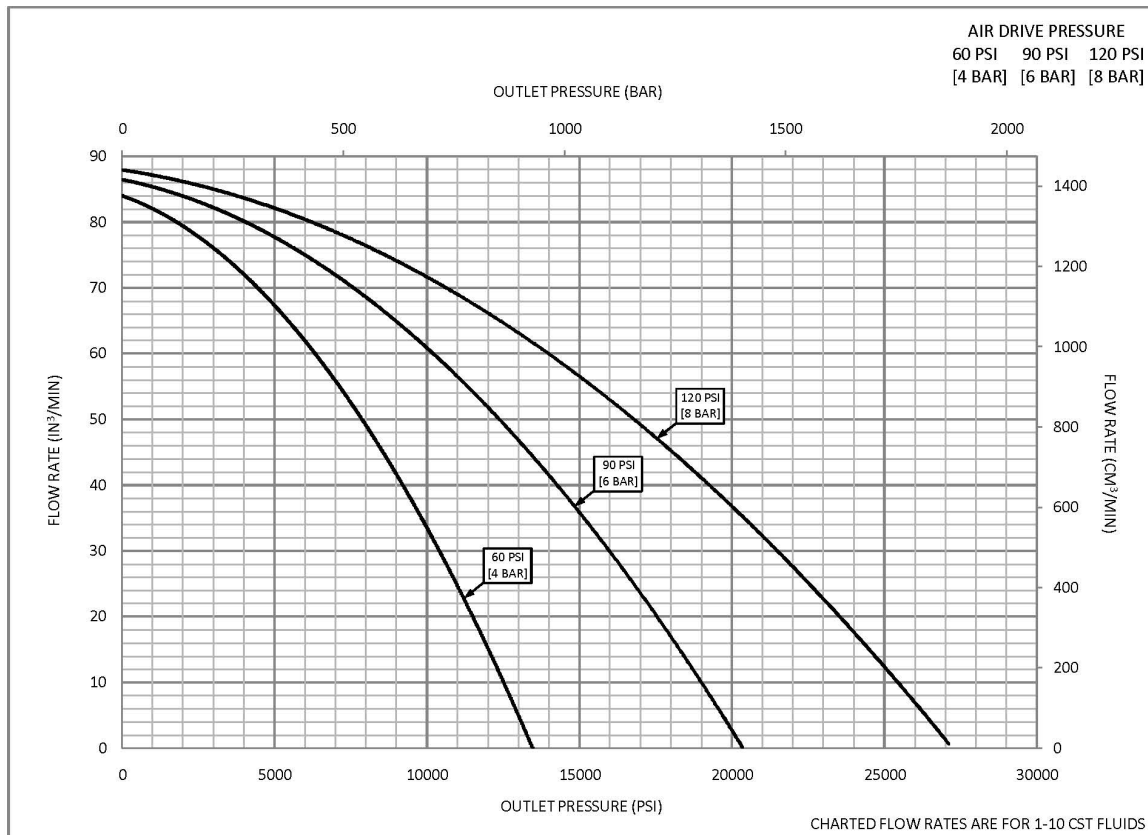

Actual flow rates will vary depending on air flow capacity, downstream flow restrictions, and fluid type.



General Information

Section 6.0 - Dimensional Data

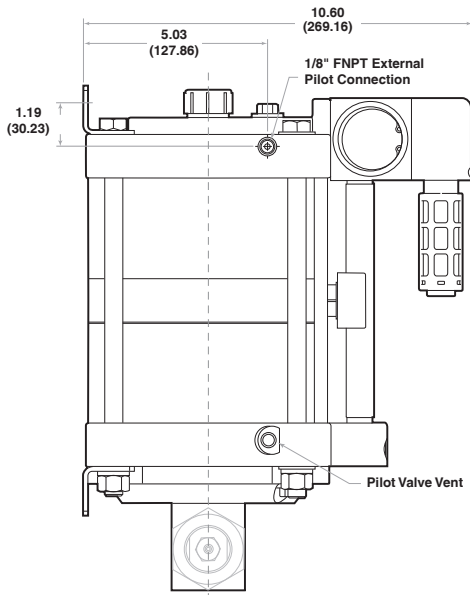

Left View

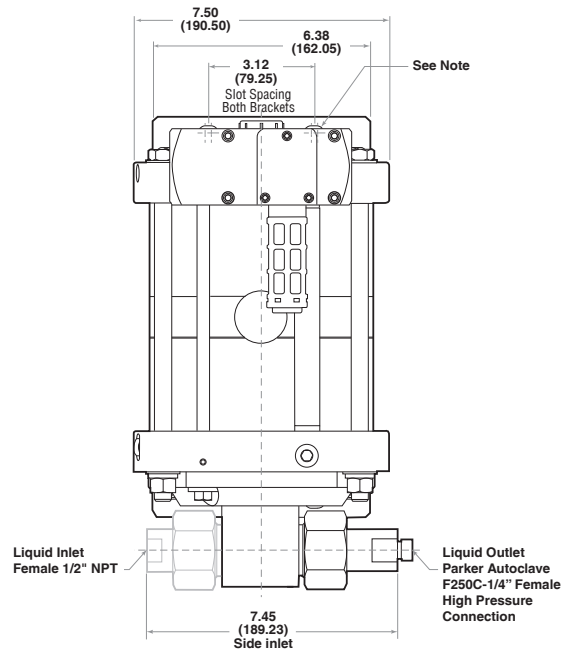

Front View

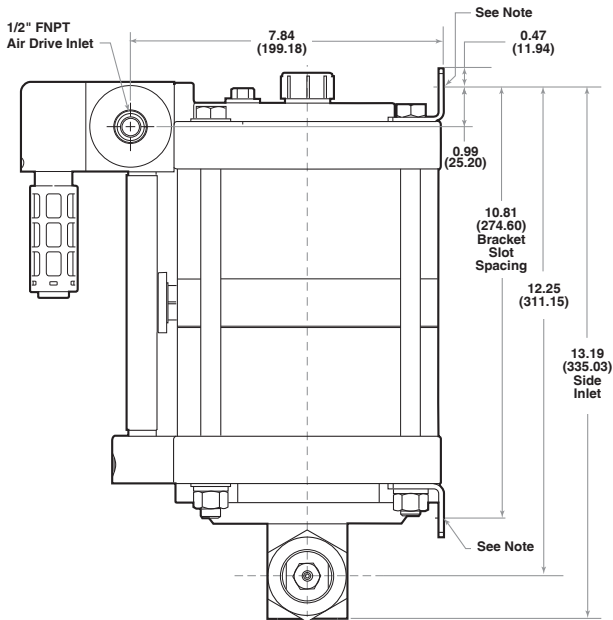

Right View

Note:

Each Mounting Bracket includes (2) x 13/32" (10.32) Slots for 3/8" Bolts.

All dimensions are for reference only and are subject to change without notice.

Primary Dimensions: Inches

Secondary Dimensions: (Millimeters)



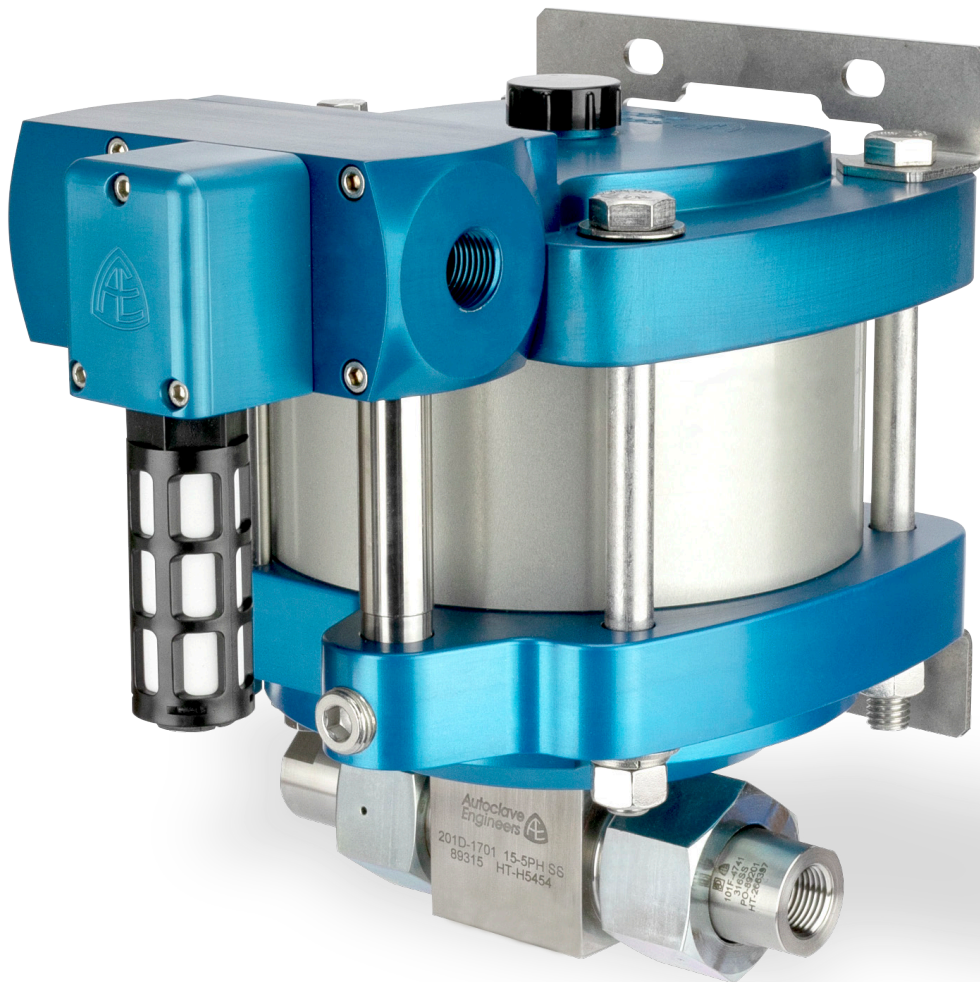

Series ASL150-01 (Single-Acting, Single Piston Air Drive)

Air-Driven, High Flow, High Pressure Liquid Pump

Technical & Performance Data Sheet

Manual: 02-9243BE | January 2022



ENGINEERING YOUR SUCCESS.

Technical Data

Section 1.0 Liquid Side Specifications

Service: Oil, Water or Water/Oil mixture and other fluids depending on material compatibility

Maximum Outlet Pressure: 21,500 psi (1482 bar)

Air to Liquid Pressure Ratio: 1:150

Volume Displacement Per Stroke: 0.39 in³ (6.4 cm³)

Inlet Connection: 1/2" FNPT

Outlet Connection: Parker Autoclave F250C-1/4" Female High Pressure

Section 2.0 Air Side Specifications

Air Drive Pressure Range: 15-150 psi (1-10 bar)* **(Note)**

Nominal Air Pressure Required: 21,500 psi (1482 bar)

Output Pressure: 145 psi (10 bar)

Inlet Port: 1/2" FNPT

Pilot Port: 1/8" FNPT (unregulated air)

Exhaust Port (muffler removed): 1/2" FNPT

Air Consumption @ 90 psi: 69 SCFM

Prelubricated at Factory

***Note:** Maximum air drive pressure is limited by maximum output pressure.

Section 3.0 General Specifications

Maximum Operating Temperature: 0-140° F (-18° to 60° C)

Net Weight: 32 lbs. (14.5 kg)

Pressure Head: 15-5 PH Stainless Steel

Plunger Description: Stainless steel plunger utilizing a proprietary multi-layer carbon based coating with diamond like carbon exterior layer - 3 times the hardness of stellite with a coefficient of friction equal to/less than PTFE

Check Valve Glands: 316 Stainless Steel (SS)

Liquid Seal: UHMWPE U-Cup with SS Spring Energizer

Air Drive Seals: Buna N



General Information

Section 4.0 - Ordering Guide

For complete information on available pump options, contact Parker Autoclave Engineers.

Typical catalog number: **ASL150-01SNP**

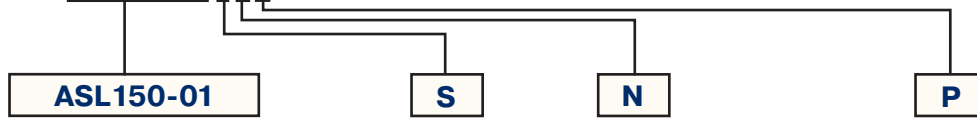

Pump Type / Size / Ratio	Liquid Inlet Location	Isolation Chamber	Liquid Seal Materials†
ASL = • Standard Liquid High Flow, High Pressure Pump • 6" Single Piston Air Drive • 1:150 Air-to-Liquid Pressure Ratio • Maximum 21,500 psi (1482 bar)	* S = Side	* N = None	P = UHMWPE U-Cup with Stainless Steel Spring Energizer

Section 5.0 - Flow Rate vs. Outlet Pressure

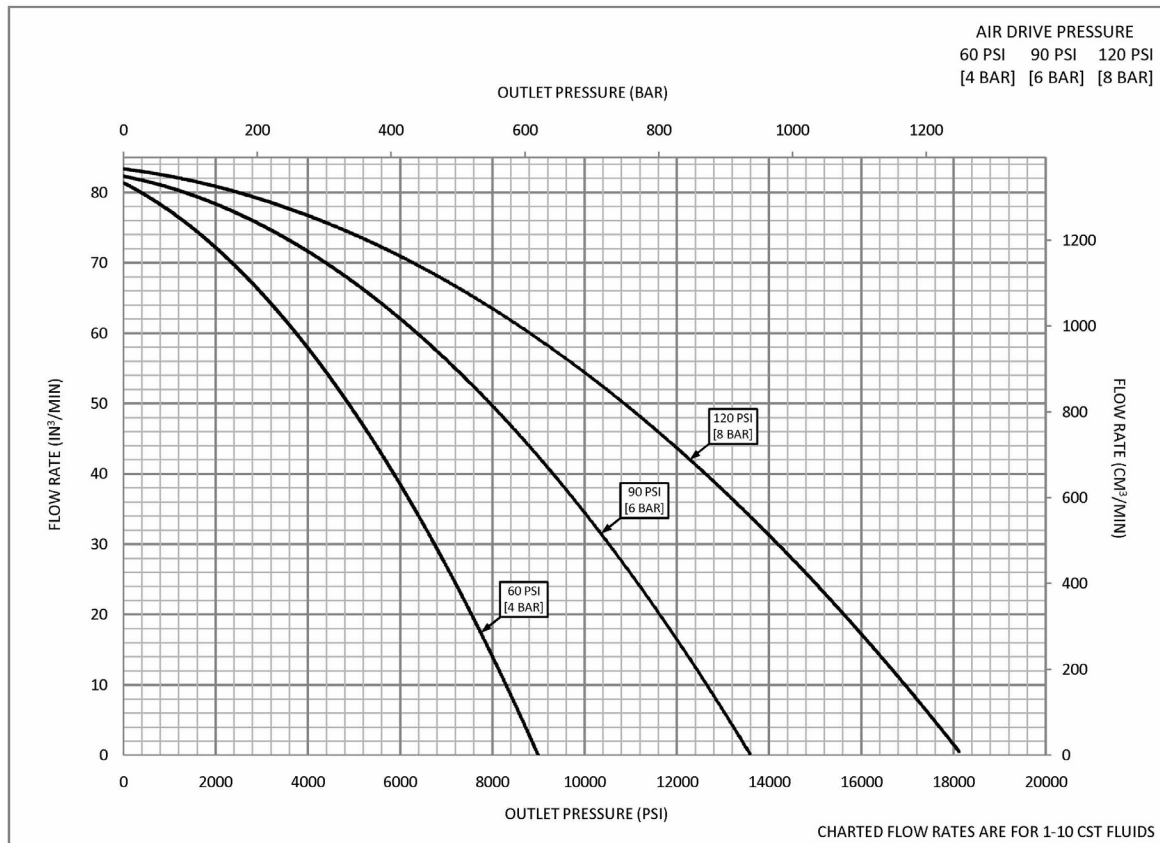

Actual flow rates will vary depending on air flow capacity, downstream flow restrictions, and fluid type.



General Information

Section 6.0 - Dimensional Data

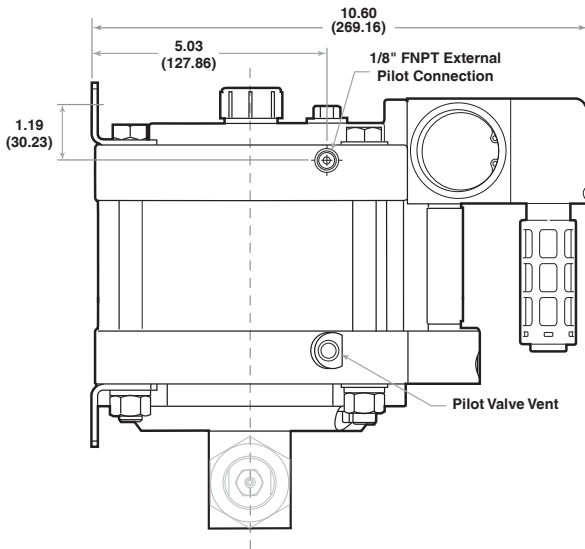

Left View

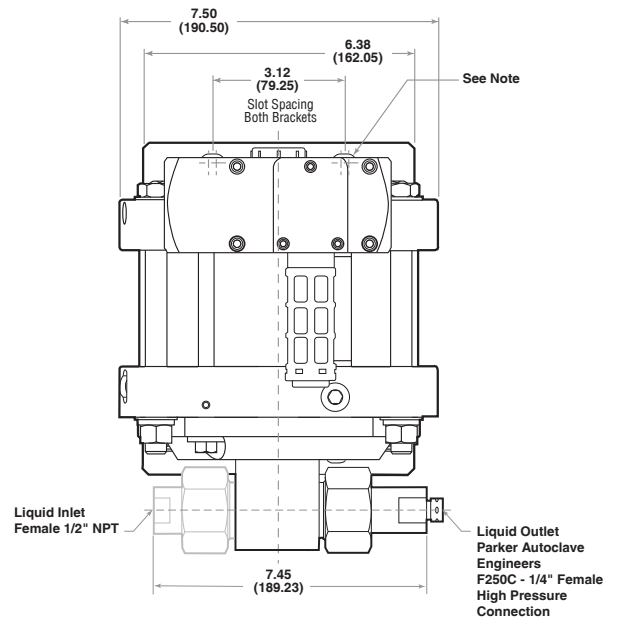

Front View

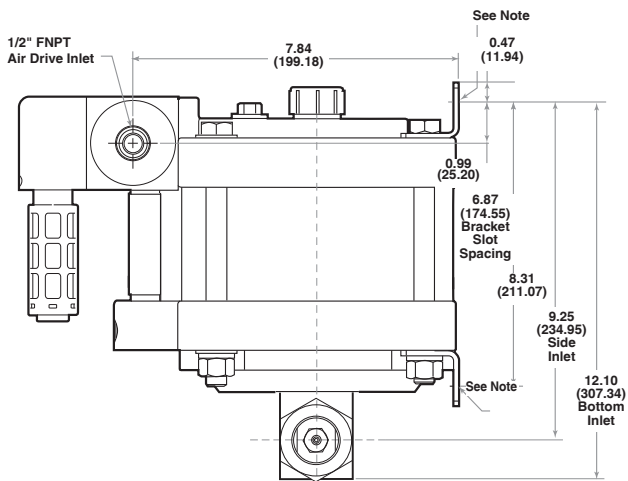

Right View

Note:

Each Mounting Bracket includes (2) x 13/32" (10.32) Slots for 3/8" Bolts.

All dimensions are for reference only and are subject to change without notice.

Primary Dimensions: Inches

Secondary Dimensions: (Millimeters)





Series ASL150-02 (Single-Acting, Dual Piston Air Drive)

Air-Driven, High Flow, High Pressure Liquid Pump

Technical & Performance Data Sheet

Manual: 02-9236BE | February 2022



ENGINEERING YOUR SUCCESS.

Technical Data

Section 1.0 Liquid Side Specifications

Service: Oil, Water or Water/Oil mixture and other fluids depending on material compatibility

Maximum Outlet Pressure: 43,000 psi (2965 bar)

Air to Liquid Pressure Ratio: 1:300

Volume Displacement Per Stroke: 0.39 in³ (6.4 cm³)

Inlet Connection: 1/2" FNPT

Outlet Connection: Parker Autoclave F250C-1/4" Female High Pressure

Section 2.0 Air Side Specifications

Air Drive Pressure Range: 15-150 psi (1-10 bar)* **(Note)**

Nominal Air Pressure Required: 43,000 psi (2965 bar)

Output Pressure: 143 psi (9.9 bar)

Inlet Port: 1/2" FNPT

Pilot Port: 1/8" FNPT (unregulated air)

Exhaust Port (muffler removed): 1/2" FNPT

Air Consumption @ 90 psi: 64 SCFM

Prelubricated at Factory

***Note:** Maximum air drive pressure is limited by maximum output pressure.

Section 3.0 General Specifications

Maximum Operating Temperature: 0-140° F (-18° to 60° C)

Net Weight: 42 lbs. (19.1 kg)

Pressure Head: 15-5 PH Stainless Steel

Plunger Description: Stainless steel plunger utilizing a proprietary multi-layer carbon based coating with diamond like carbon exterior layer - 3 times the hardness of stellite with a coefficient of friction equal to/less than PTFE

Check Valve Glands: 316 Stainless Steel (SS)

Liquid Seal: UHMWPE U-Cup with SS Spring Energizer

Air Drive Seals: Buna N



General Information

Section 4.0 - Ordering Guide

For complete information on available pump options, contact Parker Autoclave Engineers.

Typical catalog number: **ASL150-02SNP**

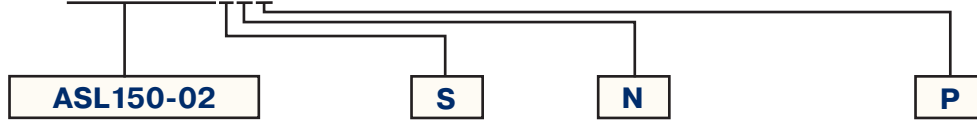

Pump Type / Size / Ratio	Liquid Inlet Location	Isolation Chamber	Liquid Seal Materials†
ASL = • Standard Liquid High Flow, High Pressure Pump • 6" Dual Piston Air Drive • 1:300 Air-to-Liquid Pressure Ratio • Maximum 43,000 psi (2965 bar)	* S = Side	* N = None	P = UHMWPE U-Cup with Elgiloy Spring Energizer

Section 5.0 - Flow Rate vs. Outlet Pressure

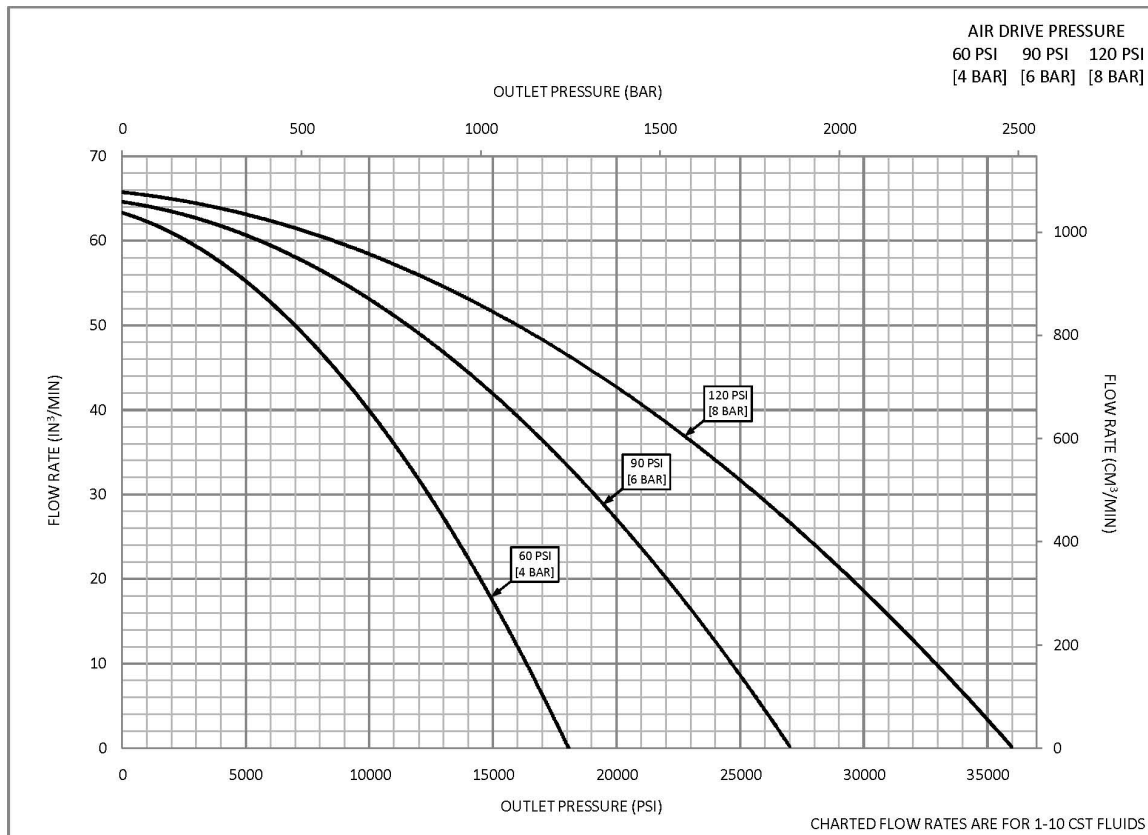

Actual flow rates will vary depending on air flow capacity, downstream flow restrictions, and fluid type.



General Information

Section 6.0 - Dimensional Data

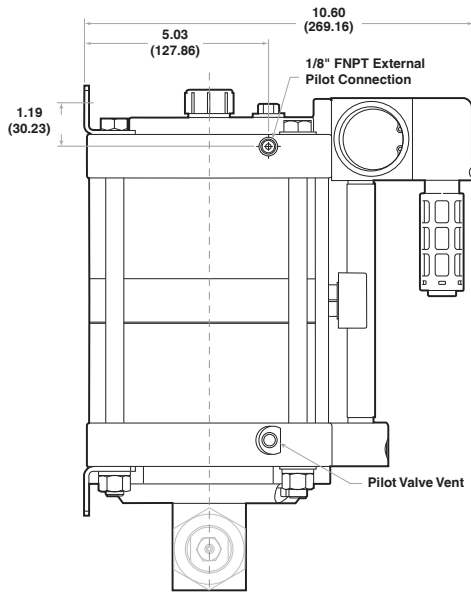

Left View

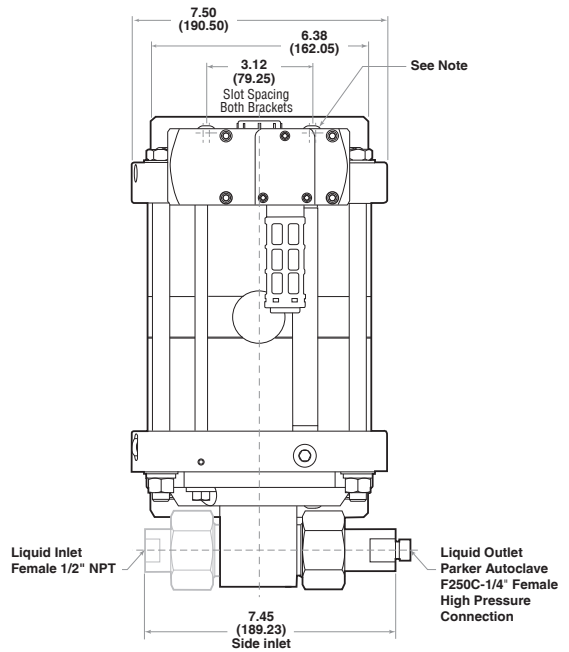

Front View

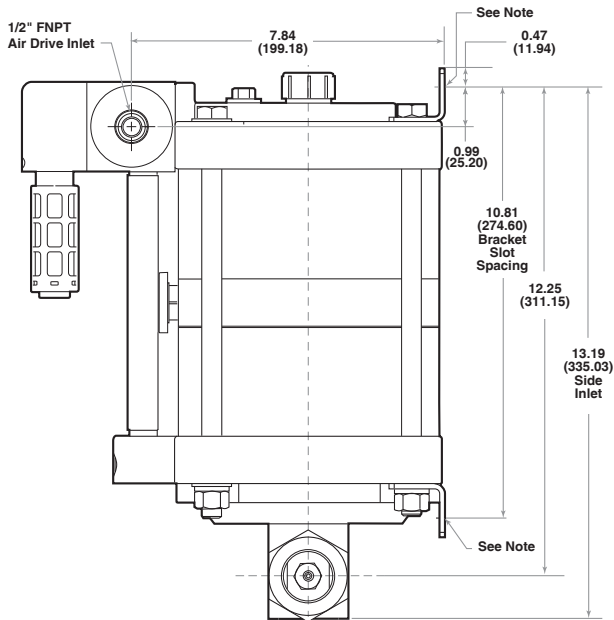

Right View

Note:

Each Mounting Bracket includes (2) x 13/32" (10.32) Slots for 3/8" Bolts.

All dimensions are for reference only and are subject to change without notice.

Primary Dimensions: Inches

Secondary Dimensions: (Millimeters)





Series ASL250-01 (Single-Acting, Single Piston Air Drive)

Air-Driven, High Flow, High Pressure Liquid Pump

Technical & Performance Data Sheet

Manual: 02-9234BE | January 2022



ENGINEERING YOUR SUCCESS.

Technical Data

Section 1.0 Liquid Side Specifications

Service: Oil, Water or Water/Oil mixture and other fluids depending on material compatibility

Maximum Outlet Pressure: 38,400 psi (2648 bar)

Air to Liquid Pressure Ratio: 1:265

Volume Displacement Per Stroke: 0.22 in³ (3.6 cm³)

Inlet Connection: 1/2" FNPT

Outlet Connection: Parker Autoclave F250C-1/4" Female High Pressure

Section 2.0 Air Side Specifications

Air Drive Pressure Range: 15-150 psi (1-10 bar)* **(Note)**

Nominal Air Pressure Required: 38,400 psi (2648 bar)

Output Pressure: 145 psi (10 bar)

Inlet Port: 1/2" FNPT

Pilot Port: 1/8" FNPT (unregulated air)

Exhaust Port (muffler removed): 1/2" FNPT

Air Consumption @ 90 psi: 69 SCFM

Prelubricated at Factory

***Note:** Maximum air drive pressure is limited by maximum output pressure.

Section 3.0 General Specifications

Maximum Operating Temperature: 0-140° F (-18° to 60° C)

Net Weight: 32 lbs. (14.5 kg)

Pressure Head: 15-5 PH Stainless Steel

Plunger Description: Stainless steel plunger utilizing a proprietary multi-layer carbon based coating with diamond like carbon exterior layer - 3 times the hardness of stellite with a coefficient of friction equal to/less than PTFE

Check Valve Glands: 316 Stainless Steel (SS)

Liquid Seal: UHMWPE U-Cup with SS Spring Energizer

Air Drive Seals: Buna N



General Information

Section 4.0 - Ordering Guide

For complete information on available pump options, contact Parker Autoclave Engineers.

Typical catalog number: **ASL250-01SNP**

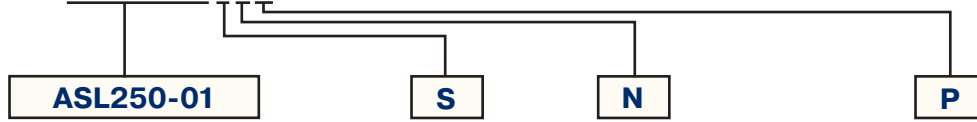

Pump Type / Size / Ratio	Liquid Inlet Location	Isolation Chamber	Liquid Seal Materials†
ASL = <ul style="list-style-type: none"> • Standard Liquid High Flow, High Pressure Pump • 6" Single Piston Air Drive • 1:265 Air-to-Liquid Pressure Ratio • Maximum 38,400 psi (2648 bar) 	* S = Side	* N = None	P = UHMWPE U-Cup with Elgiloy Spring Energizer

Section 5.0 - Flow Rate vs. Outlet Pressure

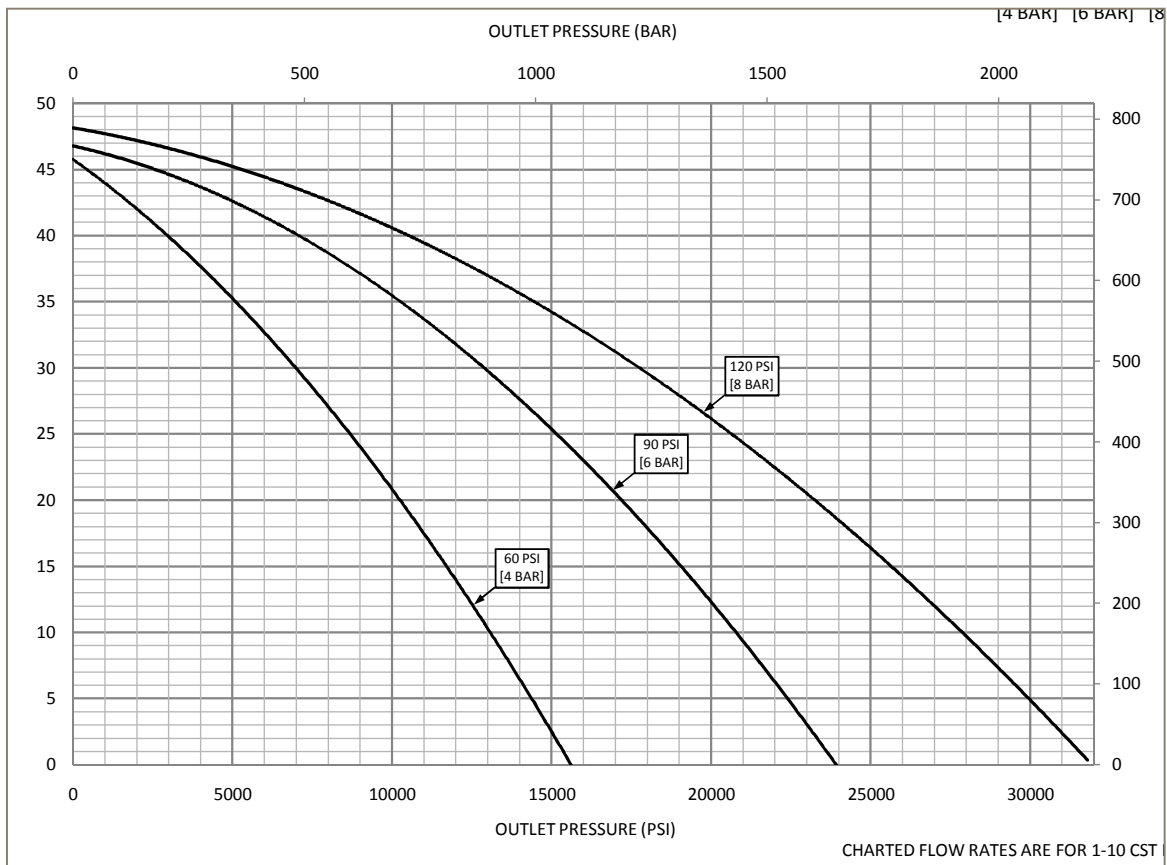

Actual flow rates will vary depending on air flow capacity, downstream flow restrictions, and fluid type.



General Information

Section 6.0 - Dimensional Data

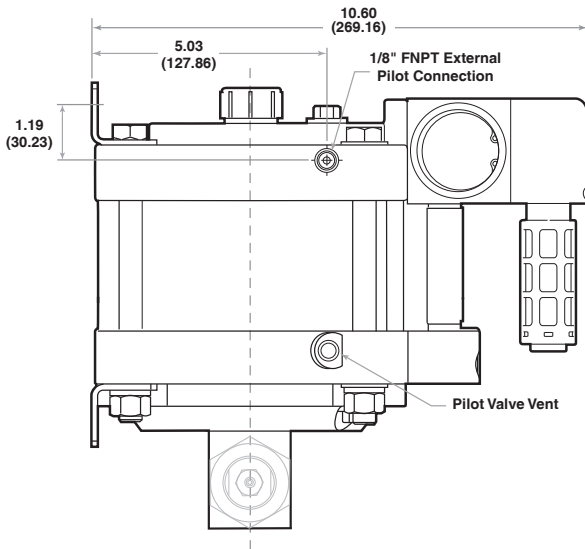

Left View

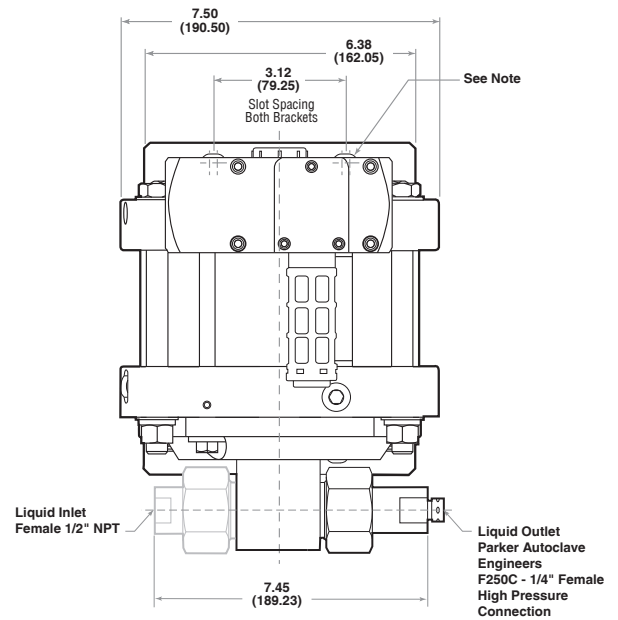

Front View

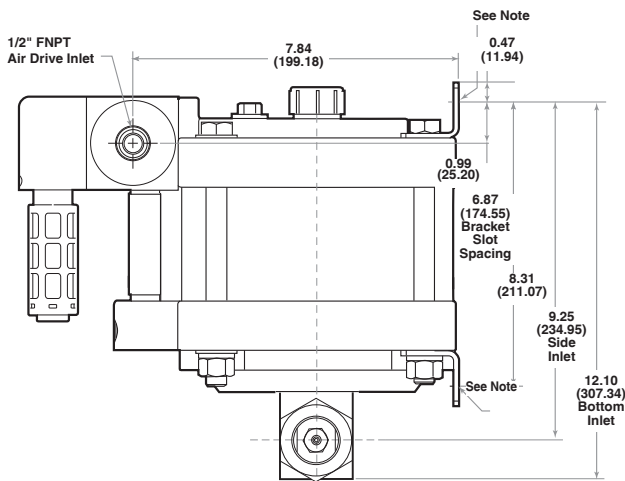

Right View

Note:

Each Mounting Bracket includes (2) x 13/32" (10.32) Slots for 3/8" Bolts.

All dimensions are for reference only and are subject to change without notice.

Primary Dimensions: Inches

Secondary Dimensions: (Millimeters)





Series ASL400-01 (Single-Acting, Single Piston Air Drive)

Air-Driven, High Flow, High Pressure Liquid Pump

Technical & Performance Data Sheet

Manual: 02-9229BE | February 2022



ENGINEERING YOUR SUCCESS.

Parker Instrumentation Products Division (IPD)

Live Chat Support is available from www.parker.com/IPD when the Chat icon “” is visible on screen.

Model # _____

Order # _____

Serial # _____

Mfg. Date _____

Drawing # _____

Complete information above for future reference.



**FAILURE, IMPROPER SELECTION OR IMPROPER USE OF THE PRODUCTS AND/OR SYSTEMS DESCRIBED HEREIN
OR RELATED ITEMS CAN CAUSE DEATH, PERSONAL INJURY AND PROPERTY DAMAGE.**

This document and other information from Parker Hannifin Corporation, its subsidiaries and authorized distributors provide product and/or system options for further investigation by users having technical expertise. It is important that you analyze all aspects of your application and review the information concerning the product or system in the current product catalog.

Due to the variety of operating conditions and applications for these products or systems, the user, through its own analysis and testing, is solely responsible for making the final selection of the products and systems and assuring that all performance, safety and warning requirements of the application are met.

The products described herein, including without limitation, product features, specifications, designs, availability and pricing, are subject to change by Parker Hannifin Corporation and its subsidiaries at any time without notice.

ALL PARKER VALVES MUST PASS A RIGID OPERATIONAL AND LEAKAGE TEST BEFORE LEAVING THE FACTORY. IT IS RECOMMENDED AFTER ANY REASSEMBLY, THE VALVE SHOULD BE TESTED BY THE USER FOR OPERATION AND LEAKAGE. IF THESE INSTRUCTIONS ARE NOT FULLY COMPLIED WITH, THE REPAIRED PRODUCT MAY FAIL AND CAUSE DAMAGE TO PROPERTY OR INJURY TO PERSONS. PARKER HANNIFIN CANNOT ASSUME RESPONSIBILITY FOR PERFORMANCE OF A CUSTOMER SERVICED VALVE.



Technical Data

Section 1.0 Liquid Side Specifications

Service: Oil, Water or Water/Oil mixture and other fluids depending on material compatibility

Maximum Outlet Pressure: 57,700 psi (3978 bar)

Air to Liquid Pressure Ratio: 1:398

Volume Displacement Per Stroke: 0.14 in³ (2.3 cm³)

Inlet Connection: 1/2" FNPT

Outlet Connection: Parker Autoclave F250C-1/4" Female High Pressure

Section 2.0 Air Side Specifications

Air Drive Pressure Range: 15-150 psi (1-10 bar)* **(Note)**

Nominal Air Pressure Required: 57,700 psi (3978 bar)

Output Pressure: 145 psi (10 bar)

Inlet Port: 1/2" FNPT

Pilot Port: 1/8" FNPT (unregulated air)

Exhaust Port (muffler removed): 1/2" FNPT

Air Consumption @ 90 psi: 70 SCFM

Prelubricated at Factory

***Note:** Maximum air drive pressure is limited by maximum output pressure.

Section 3.0 General Specifications

Maximum Operating Temperature: 0-140° F (-18° to 60° C)

Net Weight: 32 lbs. (14.5 kg)

Pressure Head: 15-5 PH Stainless Steel

Plunger Description: Stainless steel plunger utilizing a proprietary multi-layer carbon based coating with diamond like carbon exterior layer - 3 times the hardness of stellite with a coefficient of friction equal to/less than PTFE

Check Valve Glands: 316 Stainless Steel (SS)

Liquid Seal: UHMWPE U-Cup with Elgiloy Spring Energizer

Air Drive Seals: Buna N



General Information

Section 4.0 - Ordering Guide

For complete information on available pump options, contact Parker Autoclave Engineers.

Typical catalog number: **ASL400-01SNP**

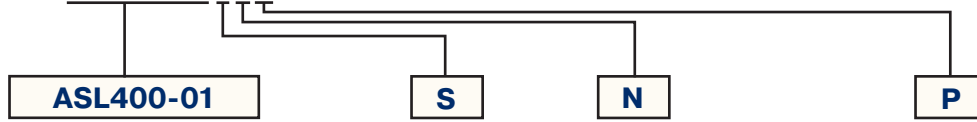

Pump Type / Size / Ratio	Liquid Inlet Location	Isolation Chamber	Liquid Seal Materials†
ASL = • Standard Liquid High Flow, High Pressure Pump • 6" Single Piston Air Drive • 1:398 Air-to-Liquid Pressure Ratio • Maximum 57,700 psi (2648 bar)	* S = Side	* N = None	P = UHMWPE U-Cup with Elgiloy Spring Energizer

Section 5.0 - Flow Rate vs. Outlet Pressure

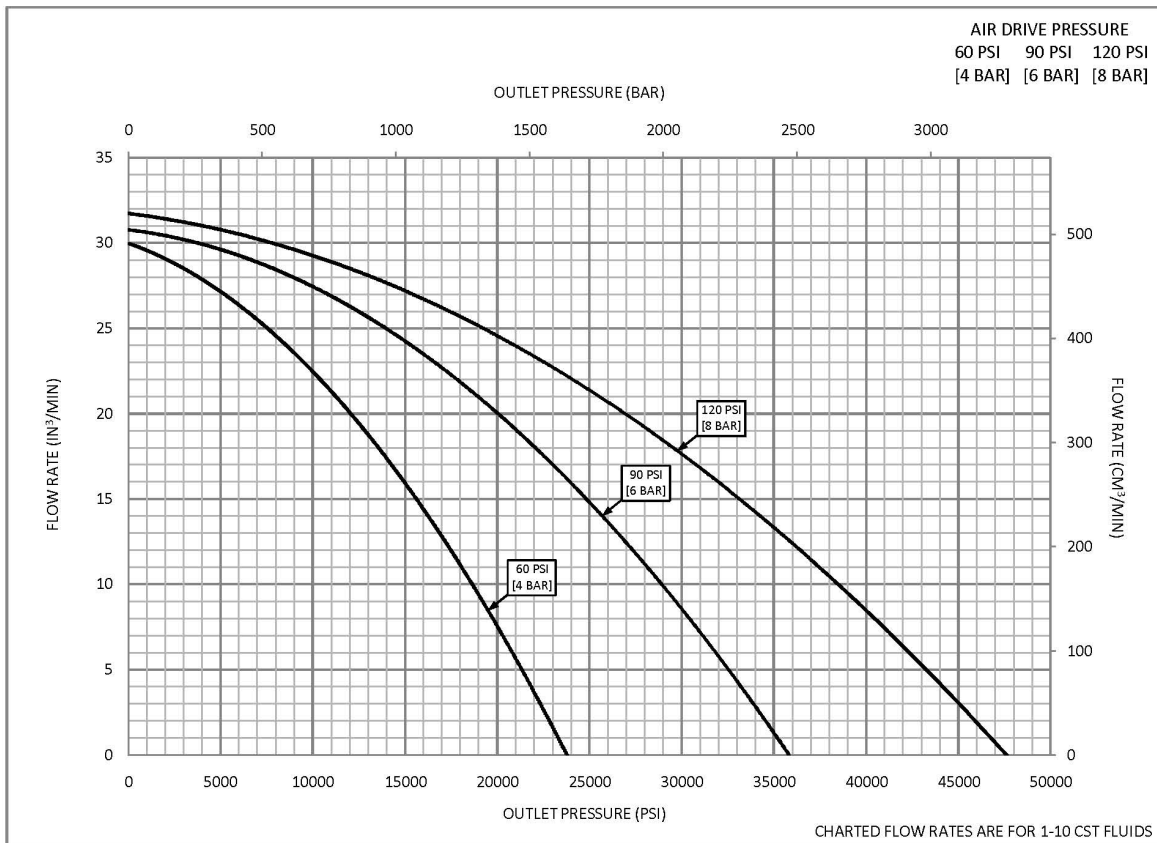

Actual flow rates will vary depending on air flow capacity, downstream flow restrictions, and fluid type.



General Information

Section 6.0 - Dimensional Data

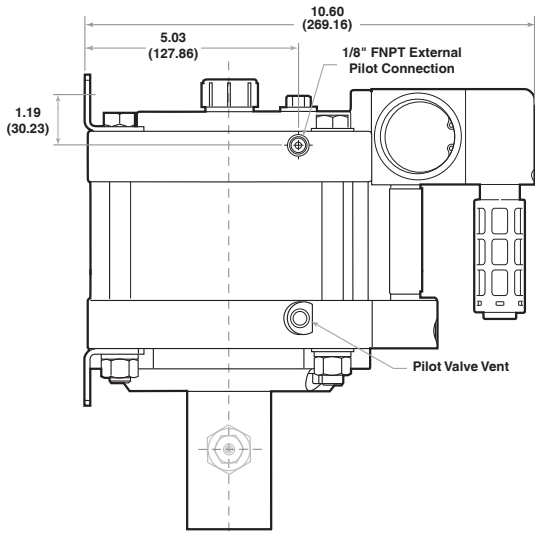

Left View

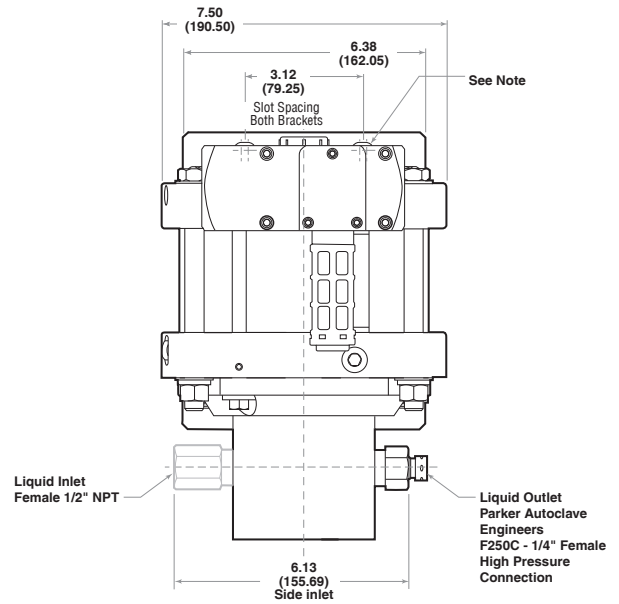

Front View

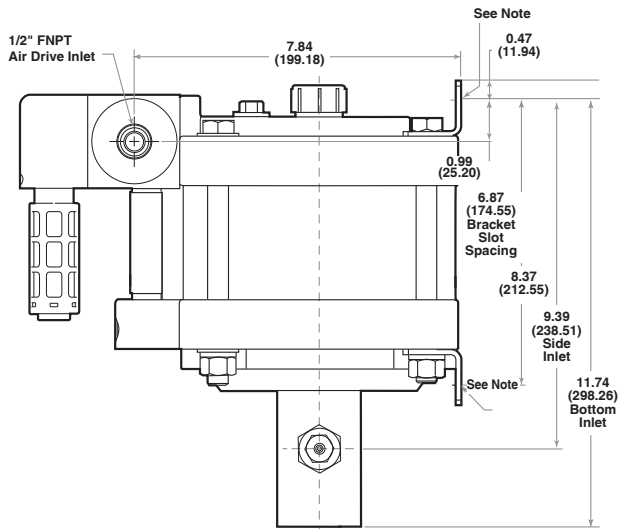

Right View

Note:

Each Mounting Bracket includes (2) x 13/32" (10.32) Slots for 3/8" Bolts.

All dimensions are for reference only and are subject to change without notice.

Primary Dimensions: Inches

Secondary Dimensions: (Millimeters)





Series ASL400-02 (Single-Acting, Dual Piston Air Drive)

Air-Driven, High Flow, High Pressure Liquid Pump

Technical & Performance Data Sheet

Manual: 02-9232BE | February 2022



ENGINEERING YOUR SUCCESS.

Technical Data

Section 1.0 Liquid Side Specifications

Service: Oil, Water or Water/Oil mixture and other fluids depending on material compatibility

Maximum Outlet Pressure: 60,000 psi (4137 bar)

Air to Liquid Pressure Ratio: 1:796

Isolation Chamber: Prevents process contamination of air section - Standard

Volume Displacement Per Stroke: 0.14 in³ (2.3 cm³)

Inlet Connection: 1/2" FNPT

Outlet Connection: Parker Autoclave F250C-1/4" Female High Pressure

Section 2.0 Air Side Specifications

Air Drive Pressure Range: 15-150 psi (1-10 bar)* **(Note)**

Nominal Air Pressure Required: 60,000 psi (4137 bar)

Output Pressure: 75 psi (5.2 bar)

Inlet Port: 1/2" FNPT

Pilot Port: 1/8" FNPT (unregulated air)

Exhaust Port (muffler removed): 1/2" FNPT

Air Consumption @ 90 psi: 48 SCFM

Prelubricated at Factory

***Note:** Maximum air drive pressure is limited by maximum output pressure.

Section 3.0 General Specifications

Maximum Operating Temperature: 0-140° F (-18° to 60° C)

Net Weight: 54 lbs. (24.5 kg)

Pressure Head: 15-5 PH Stainless Steel

Plunger Description: Tungsten Cobalt

Check Valve Glands: 15-5 PH Stainless Steel (SS)

Liquid Seal: UHMWPE U-Cup with Elgiloy Spring Energizer

Air Drive Seals: Buna N



General Information

Section 4.0 - Ordering Guide

For complete information on available pump options, contact Parker Autoclave Engineers.

Typical catalog number: **ASL400-02SCP**

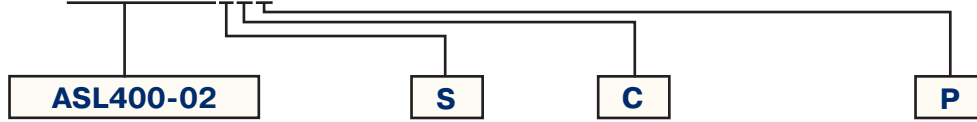

Pump Type / Size / Ratio	Liquid Inlet Location	Isolation Chamber	Liquid Seal Materials†
ASL = <ul style="list-style-type: none"> • Standard Liquid High Flow, High Pressure Pump • 6" Dual Piston Air Drive • 1:796 Air-to-Liquid Pressure Ratio • Maximum 60,000 psi (4137 bar) 	* S = Side	C = Standard	P = UHMWPE U-Cup with Elgiloy Spring Energizer

Section 5.0 - Flow Rate vs. Outlet Pressure

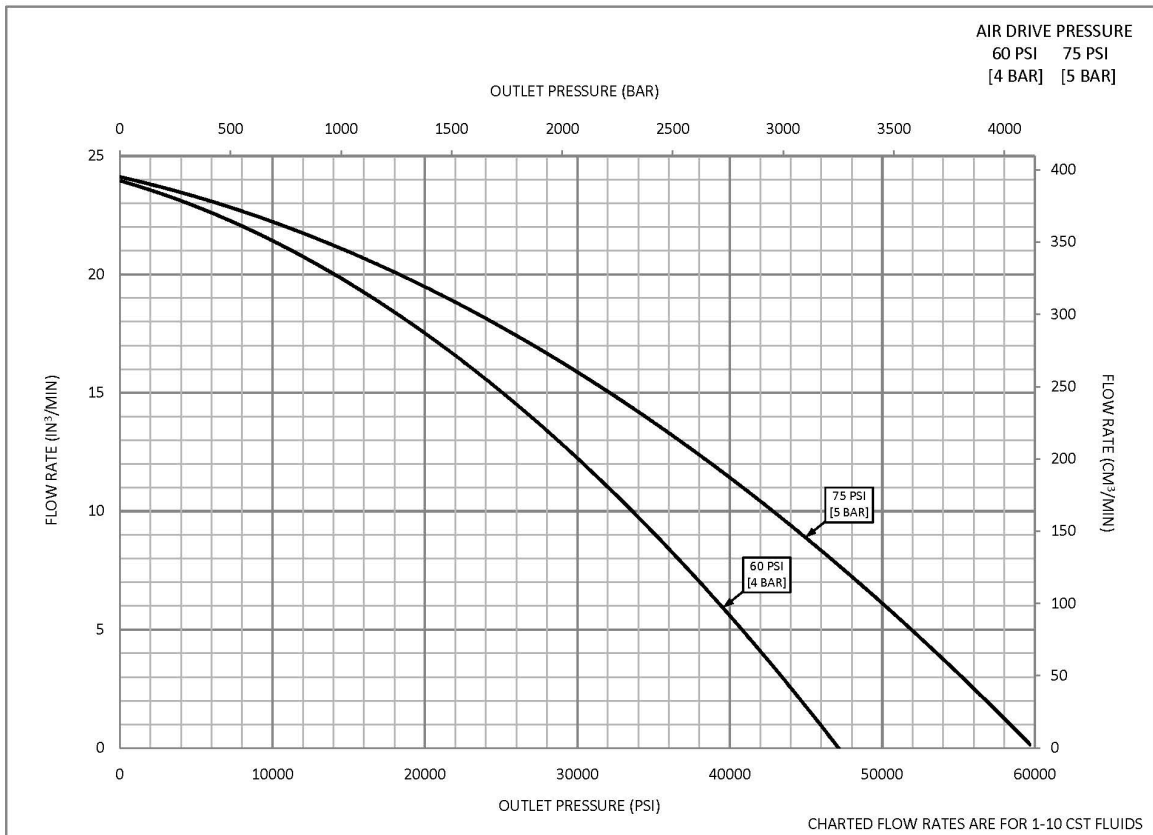

Actual flow rates will vary depending on air flow capacity, downstream flow restrictions, and fluid type.



General Information

Section 6.0 - Dimensional Data

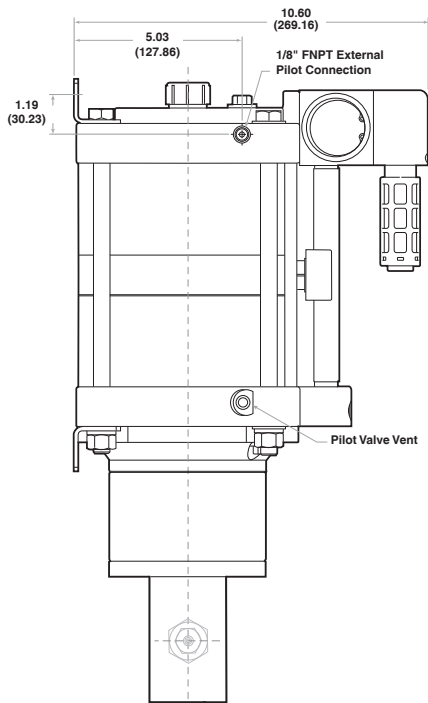

Left View

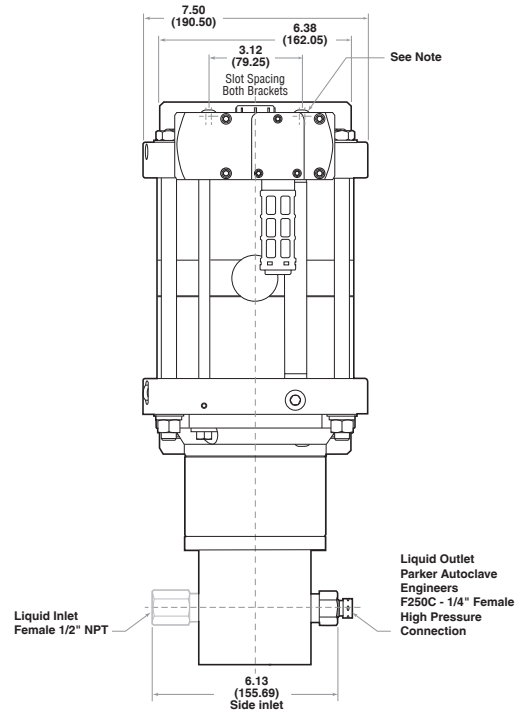

Front View

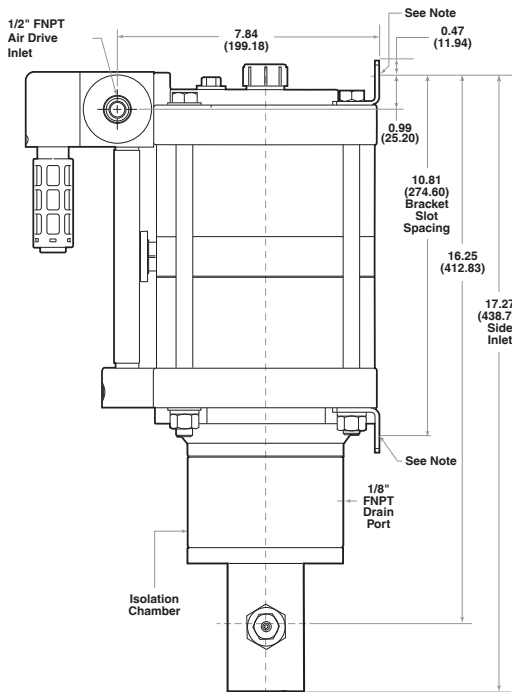

Right View

Note:

Each Mounting Bracket includes (2) x 13/32" (10.32) Slots for 3/8" Bolts.

All dimensions are for reference only and are subject to change without notice.

Primary Dimensions: Inches

Secondary Dimensions: (Millimeters)



Series ACHL



Series ACHL72-01 (Single-Acting, Single Piston Air Drive with Hand Lever)

Air-Driven, High Flow, High Pressure Liquid Pump

Technical & Performance Data Sheet

Manual: 02-9324BE | January 2022



ENGINEERING YOUR SUCCESS.

Technical Data

Manual Operation: Pump Comes standard with Hand Lever for precise pressure control, remote locations or emergency back-up applications.

Section 1.0 Liquid Side Specifications

Service: Oil, Water or Water/Oil mixture and other fluids depending on material compatibility

Maximum Outlet Pressure: 12,500 psi (862 bar)

Air to Liquid Pressure Ratio: 1:84

Volume Displacement Per Stroke: 0.09 in³ (1.47 cm³)

Inlet Connection: 3/8" FNPT

Dual Outlet Connections: Parker Autoclave F250C-1/4" Female High Pressure

Section 2.0 Air Side Specifications

Air Drive Pressure Range: 15- 150 psi (1.0- 10 bar)* **(Note)**

Nominal Air Pressure Required: 12,500 psi (862 bar)

Output Pressure: 148 psi (10.2 bar)

Inlet Port: 1/4" FNPT

Pilot Port: 1/4" FNPT

Exhaust Port (muffler removed): 1/4" FNPT

Air Consumption @ 90 psi Air (0 PSI Liquid): 13 SCFM

Prelubricated at Factory

***Note:** Maximum air drive pressure is limited by maximum output pressure.

Section 3.0 General Specifications

Maximum Operating Temperature: 0-140° F (-18° to 60° C)

Net Weight: 9 lbs. (4.1 kg)

Pressure Head: 316 Stainless Steel

Plunger Description: 440 Stainless Steel

Check Valve Glands: 15-5PH Stainless Steel (SS)

Liquid Seal: UHMWPE U-Cup with Elgiloy Spring Energizer

Air Drive Seals: Buna N



General Information

Section 4.0 - Ordering Guide

For complete information on available pump options, contact Parker Autoclave Engineers.

Typical catalog number: **ACHL72-01SNP**

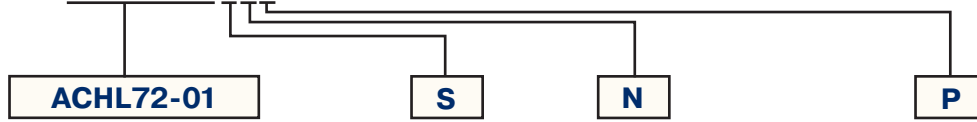

Pump Type / Size / Ratio

- ACHL** =
- Compact Liquid High Pressure Pump with Hand Lever
 - 3" Single Piston Air Drive
 - 1:84 Air-to-Liquid Pressure Ratio
 - Maximum 12,500 psi (862 bar)

Liquid Inlet Location

* **S** = Side

Isolation Chamber

N = None

Liquid Seal Materials†

* **P** = UHMWPE U-Cup with Elgiloy Spring Energizer

Air Pressure (PSI)	Stall Pressure (bar)	Hand Lever Force (LBF)
20	1355	12
40	3112	21
60	4870	30
80	6629	39
100	8386	48
120	10145	57
148	12500	70

Stall Pressure Note:

The pump's air piston is returned using a coil spring. Depending on the position of the piston during stall stroke, the stall pressure can vary ± 350 psi from the values shown on the chart.

For precise pressure control, Parker Autoclave Engineers recommends using the manual hand lever.

Section 5.0 - Liquid Flow Rate vs. Outlet Pressure

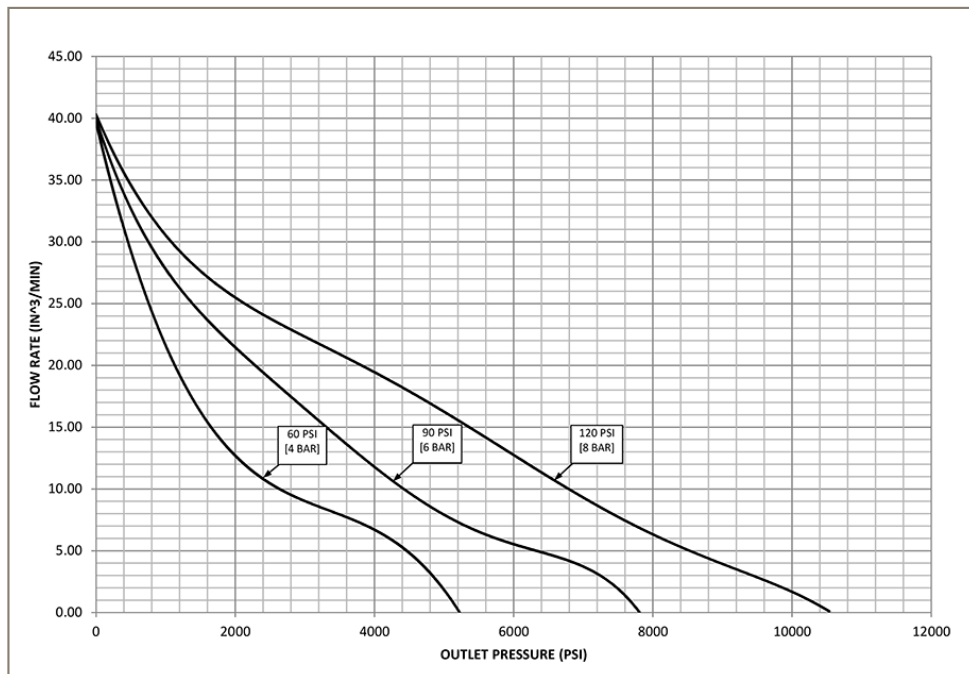

Actual flow rates will vary depending on air flow capacity, downstream flow restrictions, and fluid type.



General Information

Section 6.0 - Dimensional Data

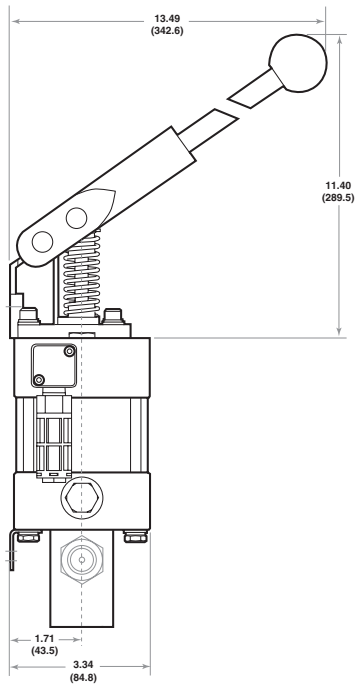

Left View

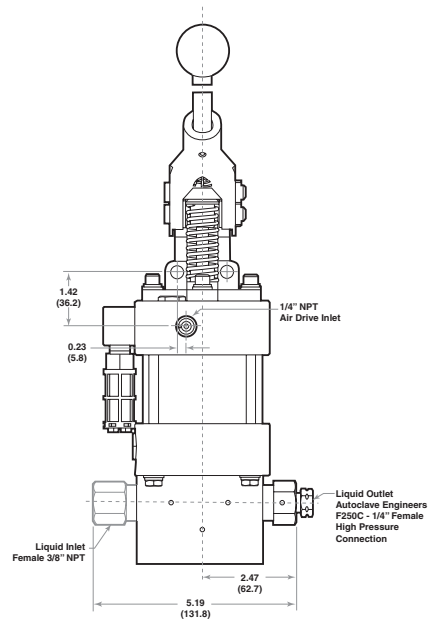

Front View

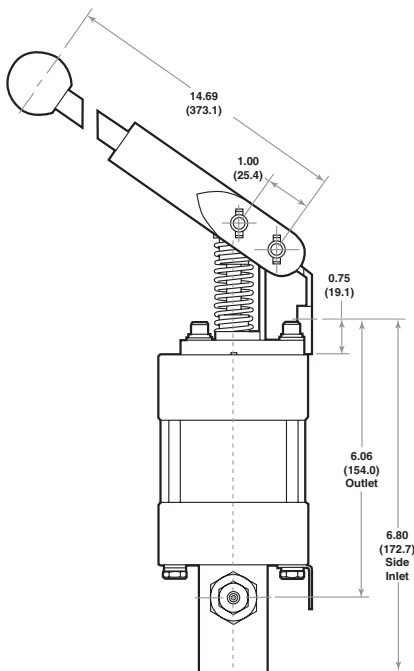

Right View

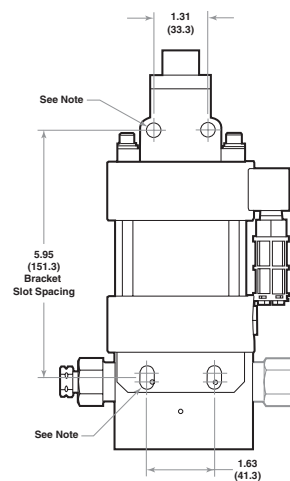

Back View

Note:

Each Mounting Bracket includes (2) 11/32" (8.73) holes for 5/16" Bolts.
 Spool air tubing not shown for clarity.
 All dimensions are for reference only and are subject to change without notice.
 Primary Dimensions: Inches
 Secondary Dimensions: (Millimeters)





Series ACHL189-01 (Single-Acting, Single Piston Air Drive with Hand Lever)

Air-Driven, High Flow, High Pressure Liquid Pump

Technical & Performance Data Sheet

Manual: 02-9246BE | January 2022



ENGINEERING YOUR SUCCESS.

Technical Data

Manual Operation: Pump Comes standard with Hand Lever for precise pressure control, remote locations or emergency back-up applications.

Section 1.0 Liquid Side Specifications

Service: Oil, Water or Water/Oil mixture and other fluids depending on material compatibility

Maximum Outlet Pressure: 31,900 psi (2200 bar)

Air to Liquid Pressure Ratio: 1:213

Volume Displacement Per Stroke: 0.035 in³ (.57 cm³)

Inlet Connection: 3/8" FNPT

Dual Outlet Connections: Parker Autoclave F250C-1/4" Female High Pressure

Section 2.0 Air Side Specifications

Air Drive Pressure Range: 15- 150 psi (1.0- 10 bar)* **(Note)**

Nominal Air Pressure Required: 31,900 psi (2200 bar)

Output Pressure: 148 psi (10.2 bar)

Inlet Port: 1/4" FNPT

Pilot Port: 1/4" FNPT

Exhaust Port (muffler removed): 1/4" FNPT

Air Consumption @ 90 psi Air (0 PSI Liquid): 13 SCFM

Prelubricated at Factory

***Note:** Maximum air drive pressure is limited by maximum output pressure.

Section 3.0 General Specifications

Maximum Operating Temperature: 0- 140° F (-18° to 60° C)

Net Weight: 9 lbs. (4.1 kg)

Pressure Head: 316 Stainless Steel

Plunger Description: 440 Stainless Steel

Check Valve Glands: 15-5PH Stainless Steel (SS)

Liquid Seal: UHMWPE U-Cup with Elgiloy Spring Energizer

Air Drive Seals: Buna N



General Information

Section 4.0 - Ordering Guide

For complete information on available pump options, contact Parker Autoclave Engineers.

Typical catalog number: **ACHL189-01SNP**

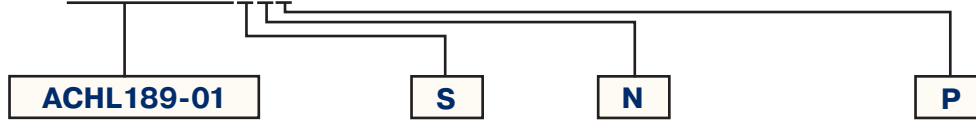

Pump Type / Size / Ratio

- ACHL** =
- Compact Liquid High Pressure Pump with Hand Lever
 - 3" Single Piston Air Drive
 - 1:213 Air-to-Liquid Pressure Ratio
 - Maximum 31,900 psi (2200 bar)

Liquid Inlet Location

* **S** = Side

Isolation Chamber

N = None

Liquid Seal Materials†

* **P** = UHMWPE U-Cup with Elgiloy Spring Energizer

Air Pressure (PSI)	Stall Pressure (bar)	Hand Lever Force (LBF)
20	3435	12
40	7890	21
60	12350	30
80	16810	39
100	21265	48
120	25725	57
148	31900	70

Stall Pressure Note:

The pump's air piston is returned using a coil spring. Depending on the position of the piston during stall stroke, the stall pressure can vary ± 350 psi from the values shown on the chart.

For precise pressure control, Parker Autoclave Engineers recommends using the manual hand lever.

Section 5.0 - Liquid Flow Rate vs. Outlet Pressure

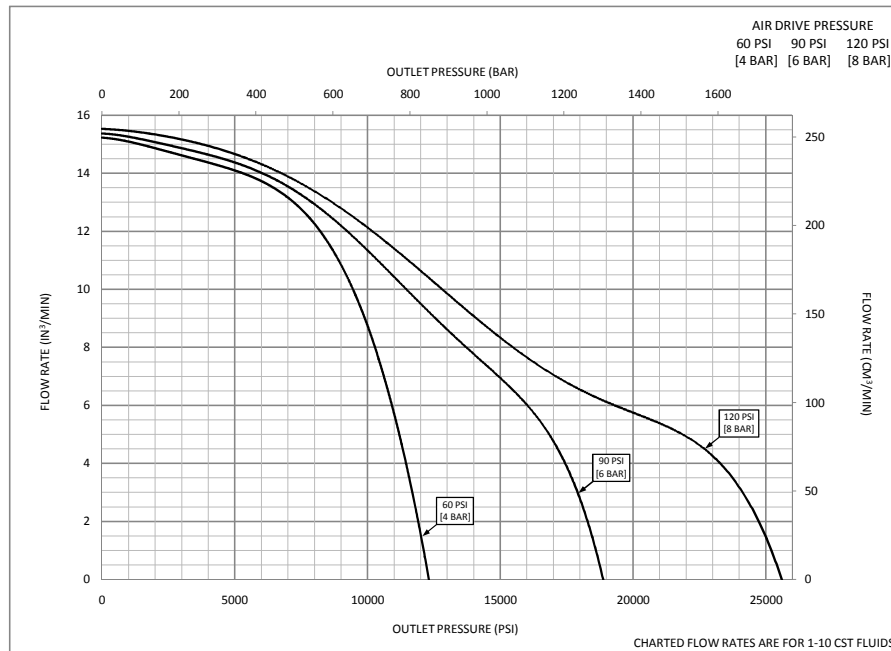

Actual flow rates will vary depending on air flow capacity, downstream flow restrictions, and fluid type.



General Information

Section 6.0 - Dimensional Data

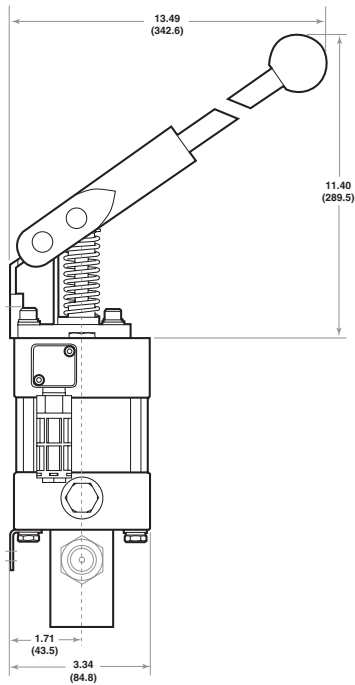

Left View

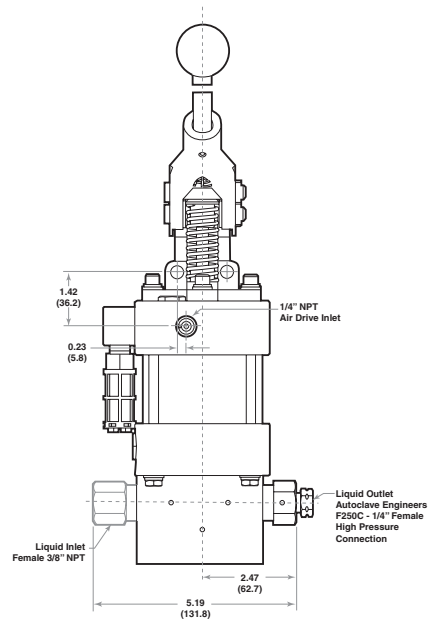

Front View

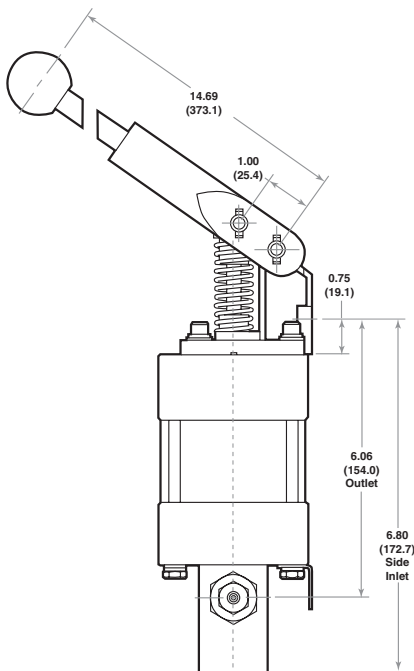

Right View

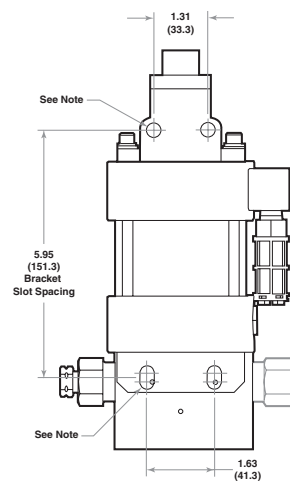

Back View

Note:

Each Mounting Bracket includes (2) 11/32" (8.73) holes for 5/16" Bolts.
 Spool air tubing not shown for clarity.
 All dimensions are for reference only and are subject to change without notice.
 Primary Dimensions: Inches
 Secondary Dimensions: (Millimeters)



Series AHL

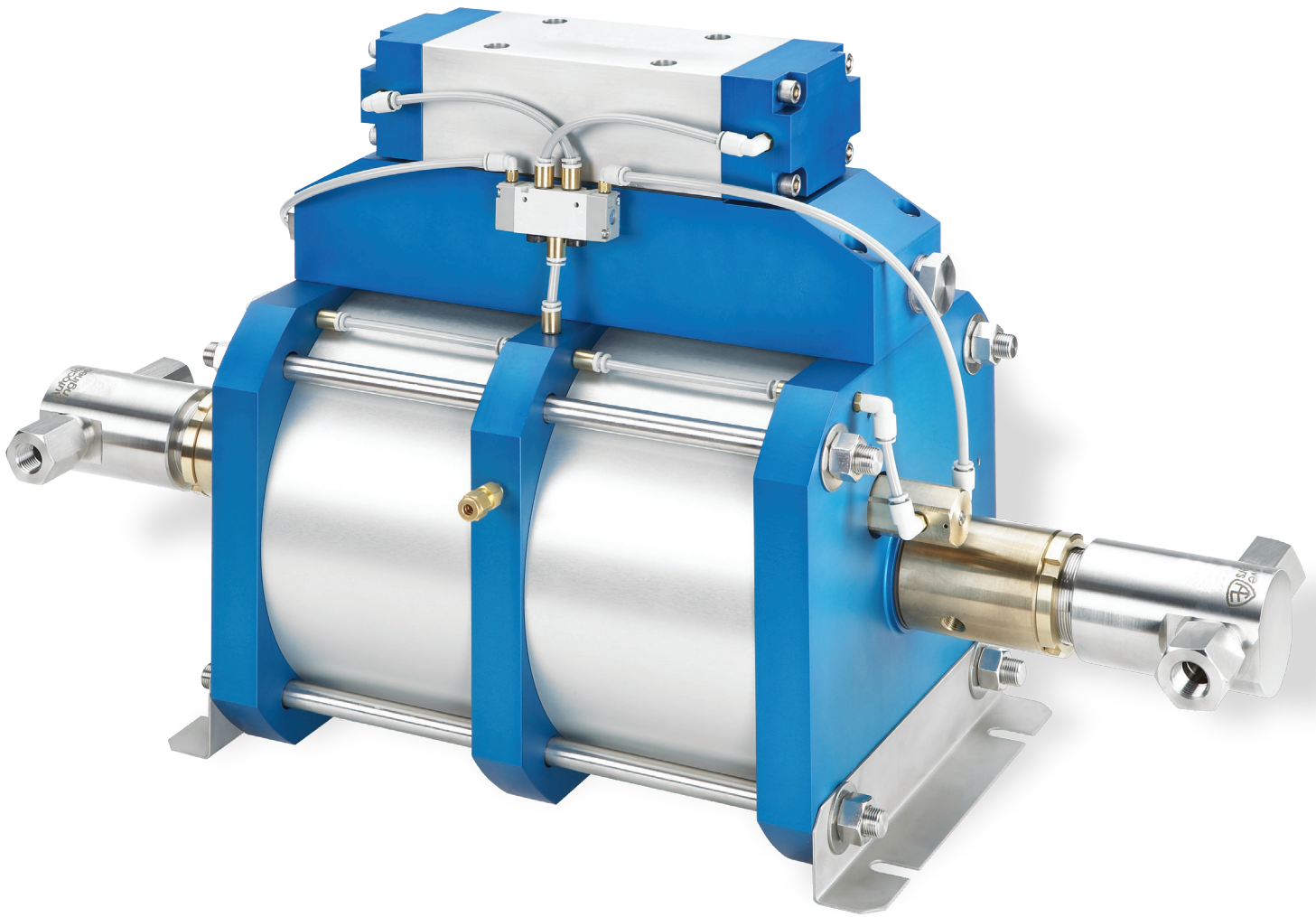

Series AHL33-2D (Double-Acting, Dual Piston Air Drive)

Air-Driven, High Flow, High Pressure Liquid Pump

Technical & Performance Data Sheet

Manual: 02-9248BE | February 2022



ENGINEERING YOUR SUCCESS.

Technical Data

Section 1.0 Liquid Side Specifications

Service: Oil, Water or Water/Oil mixture and other fluids depending on material compatibility

Maximum Outlet Pressure: 6,700 psi (462 bar)

Air to Liquid Pressure Ratio: 1:67

Isolation Chamber: Prevents process contamination of air section - Standard.

Volume Displacement Per Stroke: 15.3 in³ (250.7 cm³)

Inlet Connection: 1" FNPT

Dual Outlet Connections: 1/2" FNPT

Section 2.0 Air Side Specifications

Air Drive Pressure Range: 20- 100 psi (1.4-6.9 bar)* **(Note)**

Nominal Air Pressure Required: 6,700 psi (462 bar)

Output Pressure: 100 psi (6.9 bar)

Inlet Port: 1" Female FNPT

Pilot Port: 1/8" Female FNPT

Exhaust Port (muffler removed): 1" Female BSP

Air Consumption @ 50 psi Air (0 PSI Liquid): 290 SCFM

Prelubricated at Factory

***Note:** Maximum air drive pressure is limited by maximum output pressure.

Section 3.0 General Specifications

Maximum Operating Temperature: 0-140° F (-18° to 60° C)

Net Weight: 160 lbs. (73 kg)

Pressure Head: 15-5 PH Stainless Steel

Plunger Description: Stainless steel plunger utilizing a proprietary multi-layer carbon based coating with diamond like carbon exterior layer - 3 times the hardness of stellite with a coefficient of friction equal to/less than PTFE

Check Valve Glands: 316 Stainless Steel (SS)

Liquid Seal: Thermoplastic Polyester U-Cup and FKM O-Rings

Air Drive Seals: Buna N



General Information

Section 4.0 - Ordering Guide

For complete information on available pump options, contact Parker Autoclave Engineers.

Typical catalog number: **AHL33-2DSCTV**

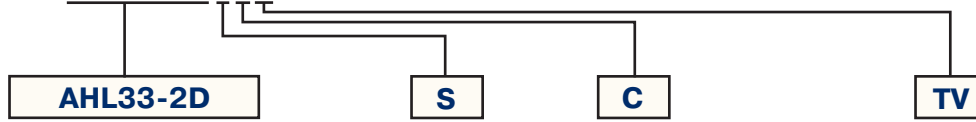

Pump Type / Size / Ratio

- AHL** =
- High Flow, Liquid High Pressure Pump
 - 10" Dual Piston Air Drive
 - 1:67 Air-to-Liquid Pressure Ratio
 - Maximum 6,700 psi (462 bar)
 - Double Acting Liquid Heads

Liquid Inlet Location

* **S** = Side

Isolation Chamber

* **C** = Included

Liquid Seal Materials†

- TV** = Thermoplastic Polyester U-Cup and FKM O-Rings
- TB** = Thermoplastic Polyester U-Cup and Buna-N O-Rings
- TC** = Thermoplastic Polyester U-Cup and Perfluoroelastomer FFKM O-Rings

Section 5.0 - Liquid Flow Rate vs. Outlet Pressure

Approximate air drive pressure: 100 psi			
Pressure (PSI)	Pressure (bar)	Flow (gpm)	Flow (liter/min)
0	0	7.6 (*see note 2)	28.8 (*see note 2)
1000	69	6.1	23.0
2000	138	5.7	21.5
3000	207	4.9	18.4
4000	276	4.0	15.2
5000	345	3.2	12.3
6000	414	1.8	6.9

Nominal Liquid Pressure (Stalled)			
Air Drive Pressure		Liquid Pressure	
PSI	bar	PSI	bar
20	1.4	1340	92.4
30	2.1	2010	138.6
40	2.8	2680	184.8
50	3.4	3350	231.0
60	4.1	4020	277.2
70	4.8	4690	323.4
80	5.5	5360	369.6
90	6.2	6030	415.8
100	6.9	6700	461.9

Note:

1. Actual flow rates will vary depending on air flow capacity, downstream flow restrictions, and fluid type.



General Information

Section 6.0 - Dimensional Data

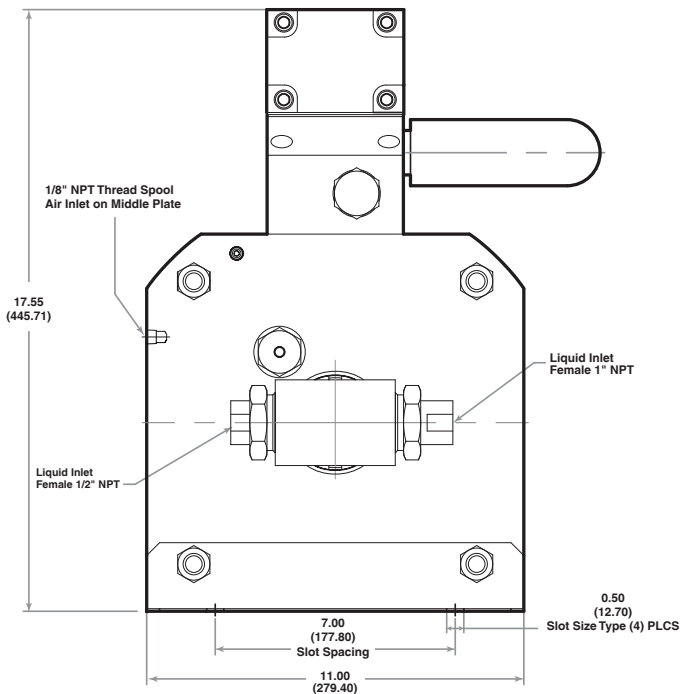

Side View

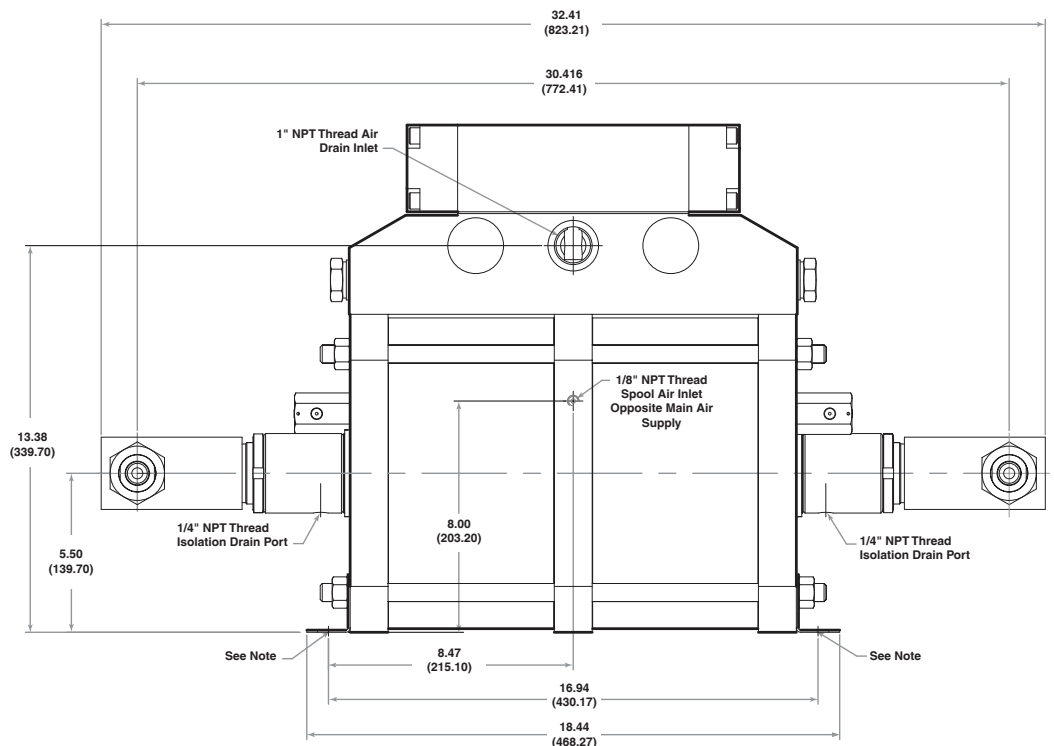

Front View

Note:

Each Mounting Bracket includes (2) x 0.50" (12.7) Slots for 7/16" Bolts.

Spool air tubing not shown for clarity.

All dimensions are for reference only and are subject to change without notice.

Primary Dimensions: Inches

Secondary Dimensions: (Millimeters)



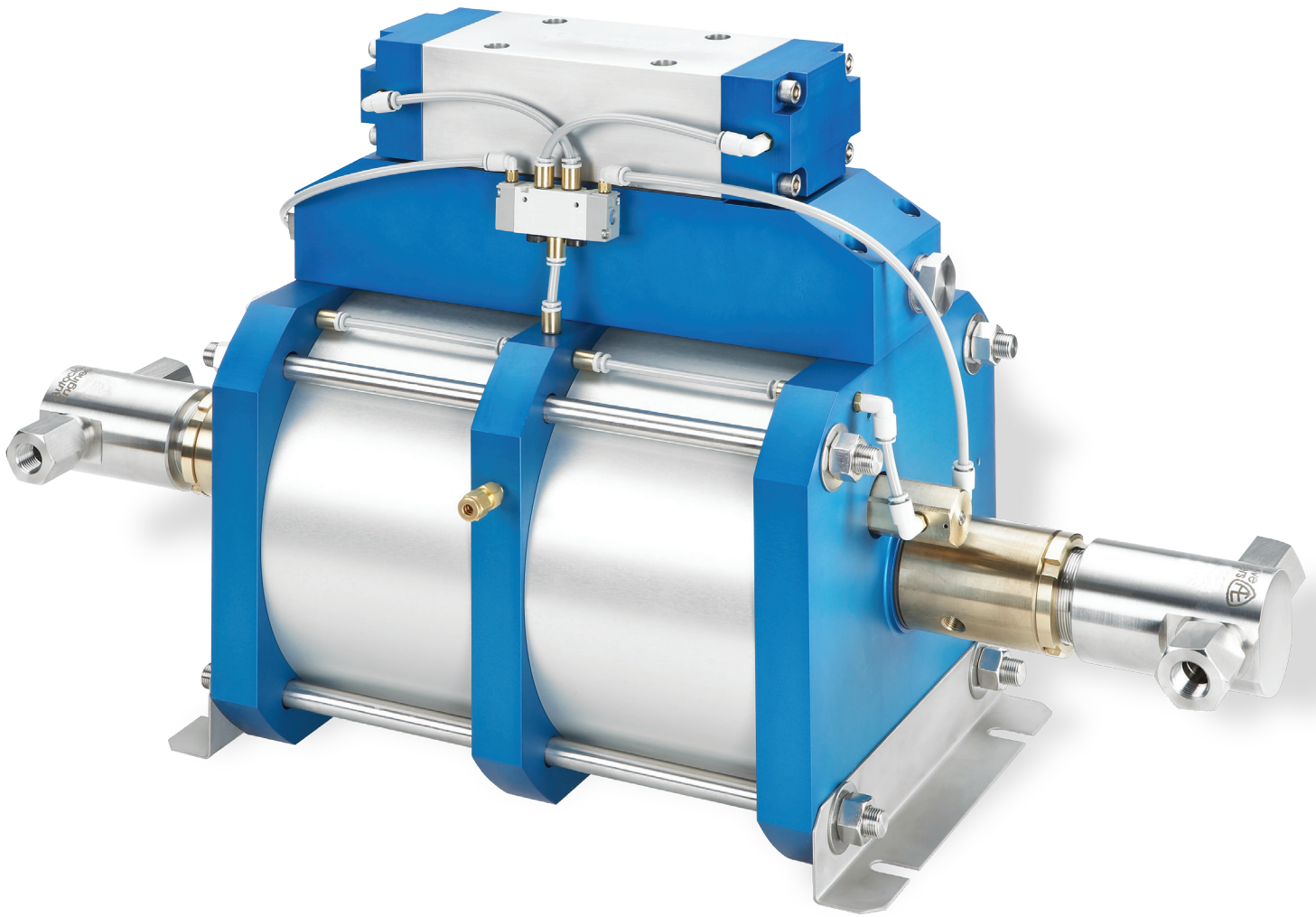

Series AHL66-2D (Double-Acting, Dual Piston Air Drive)

Air-Driven, High Flow, High Pressure Liquid Pump

Technical & Performance Data Sheet

Manual: 02-9239BE | February 2022



ENGINEERING YOUR SUCCESS.

Technical Data

Section 1.0 Liquid Side Specifications

Service: Oil, Water or Water/Oil mixture and other fluids depending on material compatibility

Maximum Outlet Pressure: 13,300 psi (917 bar)

Air to Liquid Pressure Ratio: 1:133

Isolation Chamber: Prevents process contamination of air section - Standard.

Volume Displacement Per Stroke: 7.8 in³ (127.8 cm³)

Inlet Connection: 1/2" FNPT

Dual Outlet Connections: 1/2" FNPT

Section 2.0 Air Side Specifications

Air Drive Pressure Range: 20-100 psi (1.4-6.9 bar)* **(Note)**

Nominal Air Pressure Required: 13,300 psi (917 bar)

Output Pressure: 100 psi (6.9 bar)

Inlet Port: 1" Female FNPT

Pilot Port: 1/8" Female FNPT

Exhaust Port (muffler removed): 1" Female BSP

Air Consumption @ 50 psi Air (0 PSI Liquid): 290 SCFM

Prelubricated at Factory

***Note:** Maximum air drive pressure is limited by maximum output pressure.

Section 3.0 General Specifications

Maximum Operating Temperature: 0-140° F (-18° to 60° C)

Net Weight: 160 lbs. (73 kg)

Pressure Head: 15-5 PH Stainless Steel

Plunger Description: Stainless steel plunger utilizing a proprietary multi-layer carbon based coating with diamond like carbon exterior layer - 3 times the hardness of stellite with a coefficient of friction equal to/less than PTFE

Check Valve Glands: 316 Stainless Steel (SS)

Liquid Seal: Thermoplastic Polyester U-Cup and FKM O-Rings

Air Drive Seals: Buna N



General Information

Section 4.0 - Ordering Guide

For complete information on available pump options, contact Parker Autoclave Engineers.

Typical catalog number: **AHL66-2DSCTV**

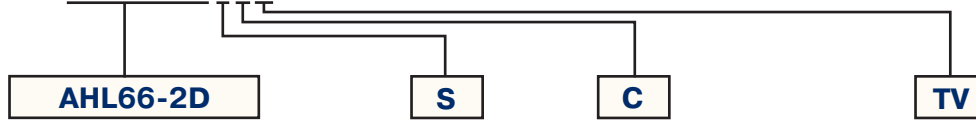

Pump Type / Size / Ratio	Liquid Inlet Location	Isolation Chamber	Liquid Seal Materials†
AHL = <ul style="list-style-type: none"> • High Flow, Liquid High Pressure Pump • 10" Dual Piston Air Drive • 1:133 Air-to-Liquid Pressure Ratio • Maximum 13,300 psi (917 bar) • Double Acting Liquid Heads 	* S = Side	* C = Included	TV = Thermoplastic Polyester U-Cup and FKM O-Rings TB = Thermoplastic Polyester U-Cup and Buna-N O-Rings TC = Thermoplastic Polyester U-Cup and Perfluoroelastomer FFKM O-Rings

Section 5.0 - Liquid Flow Rate vs. Outlet Pressure

Approximate air drive pressure: 100 psi			
Pressure (PSI)	Pressure (bar)	Flow (gpm)	Flow (liter/min)
0	0	3.6* <i>see note 2</i>	13.7 * <i>see note 2</i>
1000	69	3.4	12.9
2000	138	3.1	12.0
3000	207	2.9	11.2
4000	276	2.7	10.3
5000	345	2.5	9.5
6000	414	2.3	8.7
7000	483	2.2	8.2
8000	552	2.0	7.7
9000	621	1.8	6.7
10000	690	1.5	5.7
11000	759	1.3	4.8
12000	828	1.0	3.9

Nominal Liquid Pressure (Stalled)			
Air Drive Pressure		Liquid Pressure	
PSI	bar	PSI	bar
20	1.4	2660	183.4
30	2.1	3990	275.2
40	2.8	5320	366.9
50	3.4	6650	458.6
60	4.1	7980	550.3
70	4.8	9310	642.1
80	5.5	10640	733.8
90	6.2	11970	825.5
100	6.9	13300	917.2

Note:

1. Actual flow rates will vary depending on air flow capacity, downstream flow restrictions, and fluid type.



General Information

Section 6.0 - Dimensional Data

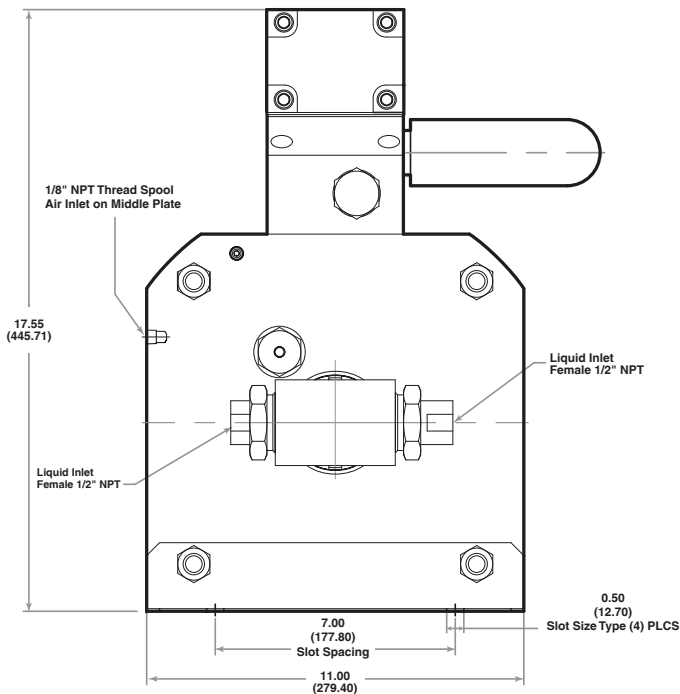

Side View

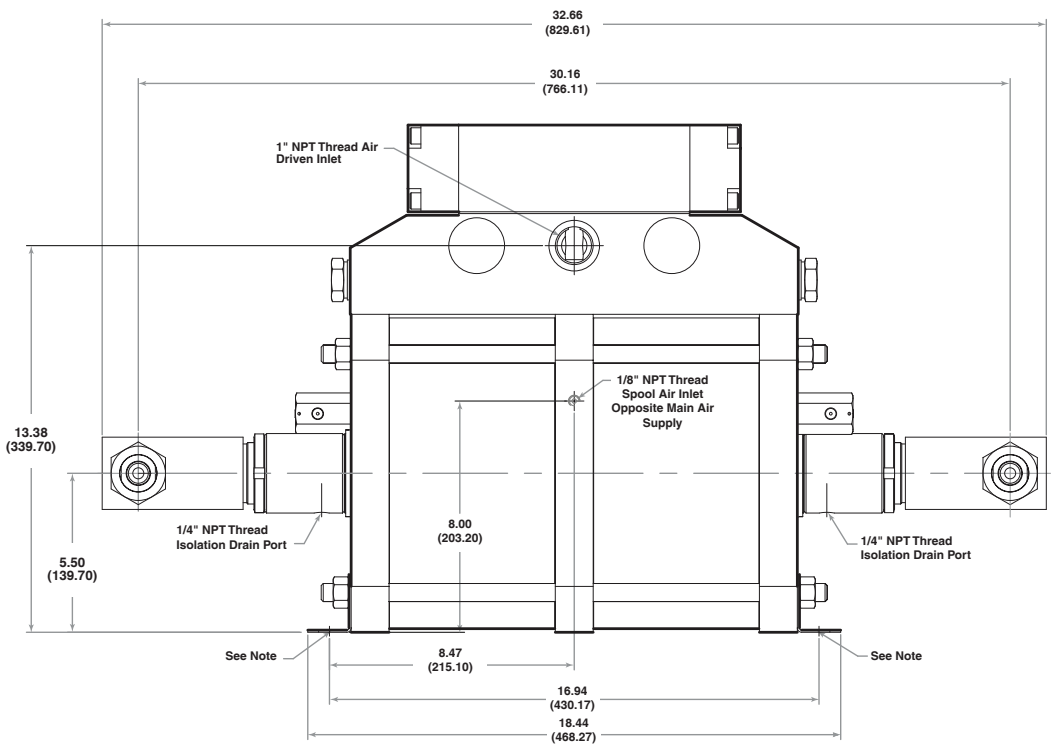

Front View

Note:

Each Mounting Bracket includes (2) x 0.50" (12.7) Slots for 7/16" Bolts.

Spool air tubing not shown for clarity.

All dimensions are for reference only and are subject to change without notice.

Primary Dimensions: Inches

Secondary Dimensions: (Millimeters)



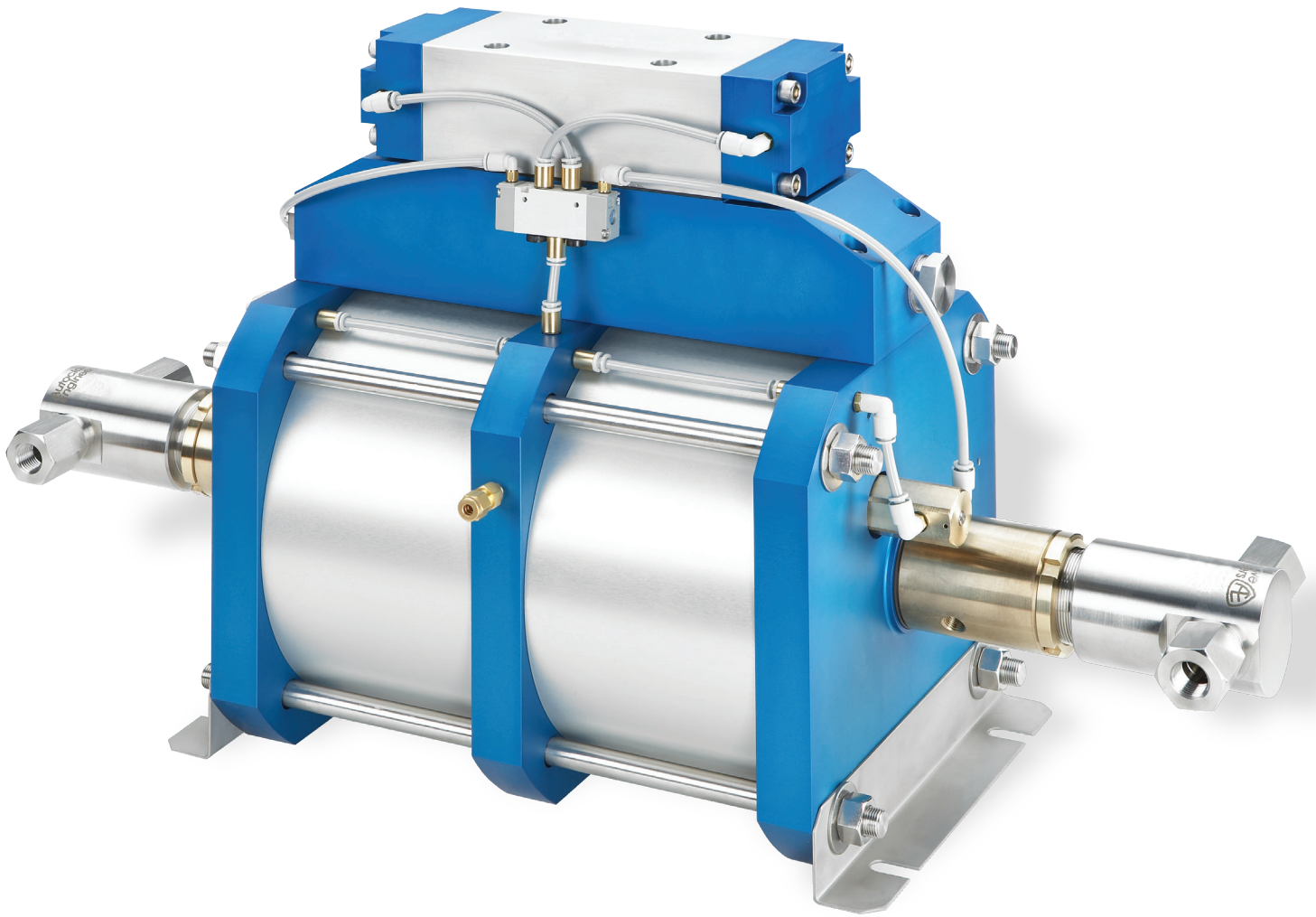

Series AHL118-2D (Double-Acting, Dual Piston Air Drive)

Air-Driven, High Flow, High Pressure Liquid Pump

Technical & Performance Data Sheet

Manual: 02-9339BE | February 2022



ENGINEERING YOUR SUCCESS.

Technical Data

Section 1.0 Liquid Side Specifications

Service: Oil, Water or Water/Oil mixture and other fluids depending on material compatibility

Maximum Outlet Pressure: 22,500 psi (1551 bar)

Air to Liquid Pressure Ratio: 1:239

Isolation Chamber: Prevents process contamination of air section - Standard.

Volume Displacement Per Stroke: 4.4 in³ (72.18 cm³)

Inlet Connection: 1/2" FNPT

Dual Outlet Connections: SF562CX
(Contact Parker Autoclave for additional options)

Section 2.0 Air Side Specifications

Air Drive Pressure Range: 20-95 psi (1.4-6.5 bar)* **(Note)**

Nominal Air Pressure Required: 22,500 psi (1551 bar)

Output Pressure: 95 psi (6.59 bar)

Inlet Port: 1" Female FNPT

Pilot Port: 1/8" Female FNPT

Exhaust Port (muffler removed): 1" Female BSP

Air Consumption @ 50 psi Air (0 PSI Liquid): 290 SCFM

Prelubricated at Factory

***Note:** Maximum air drive pressure is limited by maximum output pressure.

Section 3.0 General Specifications

Maximum Operating Temperature: 0-140° F (-18° to 60° C)

Net Weight: 160 lbs. (73 kg)

Pressure Head: 15-5 PH Stainless Steel

Plunger Description: Stainless steel plunger utilizing a proprietary multi-layer carbon based coating with diamond like carbon exterior layer - 3 times the hardness of stellite with a coefficient of friction equal to/less than PTFE

Check Valve Glands: 316 Stainless Steel (SS)

Liquid Seal: See Ordering Guide for options

Air Drive Seals: Buna N



General Information

Section 4.0 - Ordering Guide

For complete information on available pump options, contact Parker Autoclave Engineers.

Typical catalog number: **AHL118-2DSCTV**

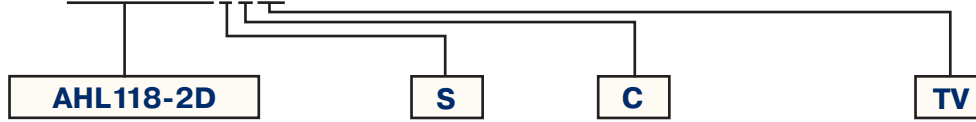

Pump Type / Size / Ratio

- AHL** =
- High Flow, Liquid High Pressure Pump
 - 10" Dual Piston Air Drive
 - 1:239 Air-to-Liquid Pressure Ratio
 - Maximum 22,500 psi (1551 bar)
 - Double Acting Liquid Heads

Liquid Inlet Location

* **S** = Side

Isolation Chamber

* **C** = Included

Liquid Seal Materials†

- TV** = Thermoplastic Polyester U-Cup and FKM O-Rings
- TB** = Thermoplastic Polyester U-Cup and Buna-N O-Rings
- TC** = Thermoplastic Polyester U-Cup and Perfluoroelastomer FFKM O-Rings

Section 5.0 - Liquid Flow Rate vs. Outlet Pressure

Approximate air drive pressure: 100 psi			
Pressure (PSI)	Pressure (bar)	Flow (gpm)	Flow (liter/min)
0	0	2.0	7.7
2000	138	1.8	6.9
4000	276	2.0	6.3
6000	414	1.5	5.8
8000	552	1.4	5.4
10000	689	1.3	5.1
12000	827	1.2	4.7
14000	965	1.1	4.3
16000	1103	1.0	3.8
18000	1241	0.8	3.1
20000	1379	0.6	2.3
22500	1551	0.2	0.8

Nominal Liquid Pressure (Stalled)			
Air Drive Pressure		Liquid Pressure	
PSI	bar	PSI	bar
20	1.4	4780	329.6
30	2.1	7170	494.4
40	2.8	9560	659.1
50	3.4	11950	823.9
60	4.1	14340	988.7
70	4.8	16730	1153.5
80	5.5	19120	1318.3
90	6.2	21510	1483.1
95	6.6	22500	1551.3

Note:

1. Actual flow rates will vary depending on air flow capacity, downstream flow restrictions, and fluid type.



General Information

Section 6.0 - Dimensional Data

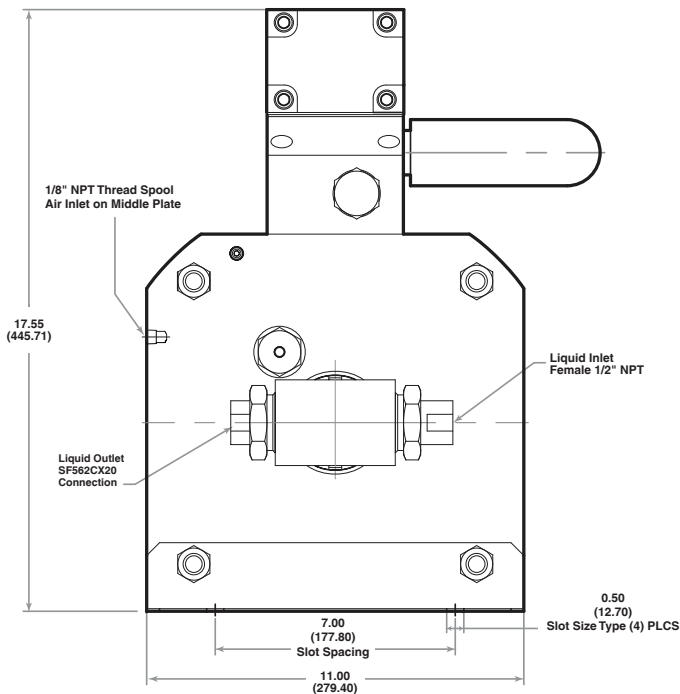

Side View

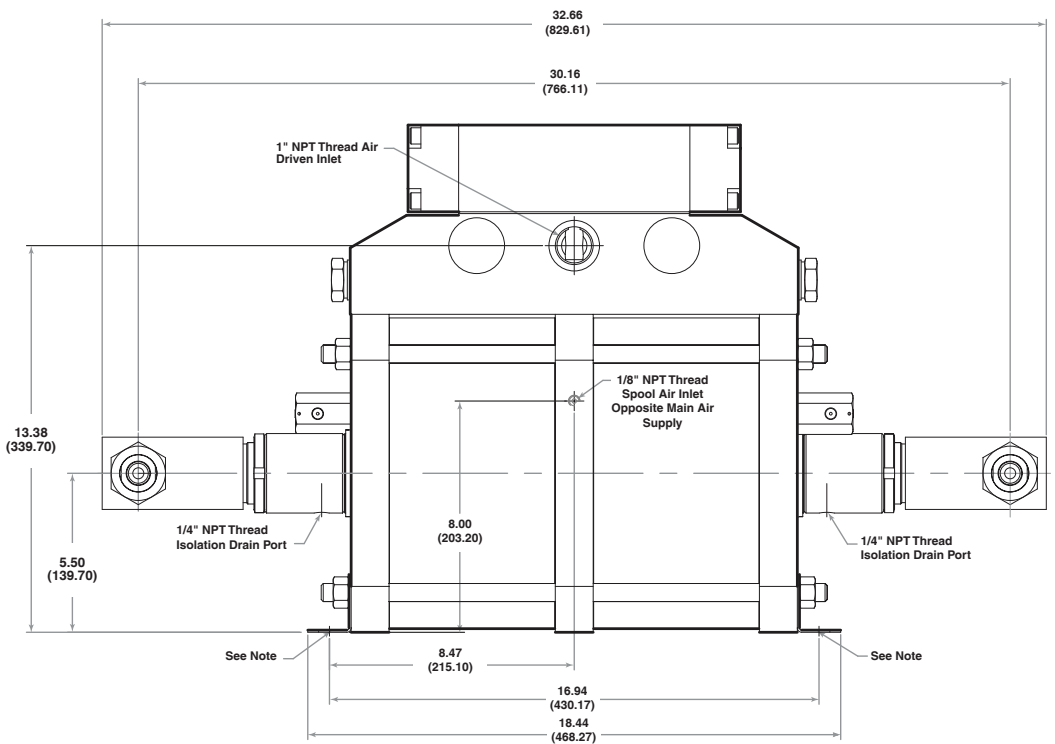

Front View

Note:

Each Mounting Bracket includes (2) x 0.50" (12.7) Slots for 7/16" Bolts.

Spool air tubing not shown for clarity.

All dimensions are for reference only and are subject to change without notice.

Primary Dimensions: Inches

Secondary Dimensions: (Millimeters)



Series AFL

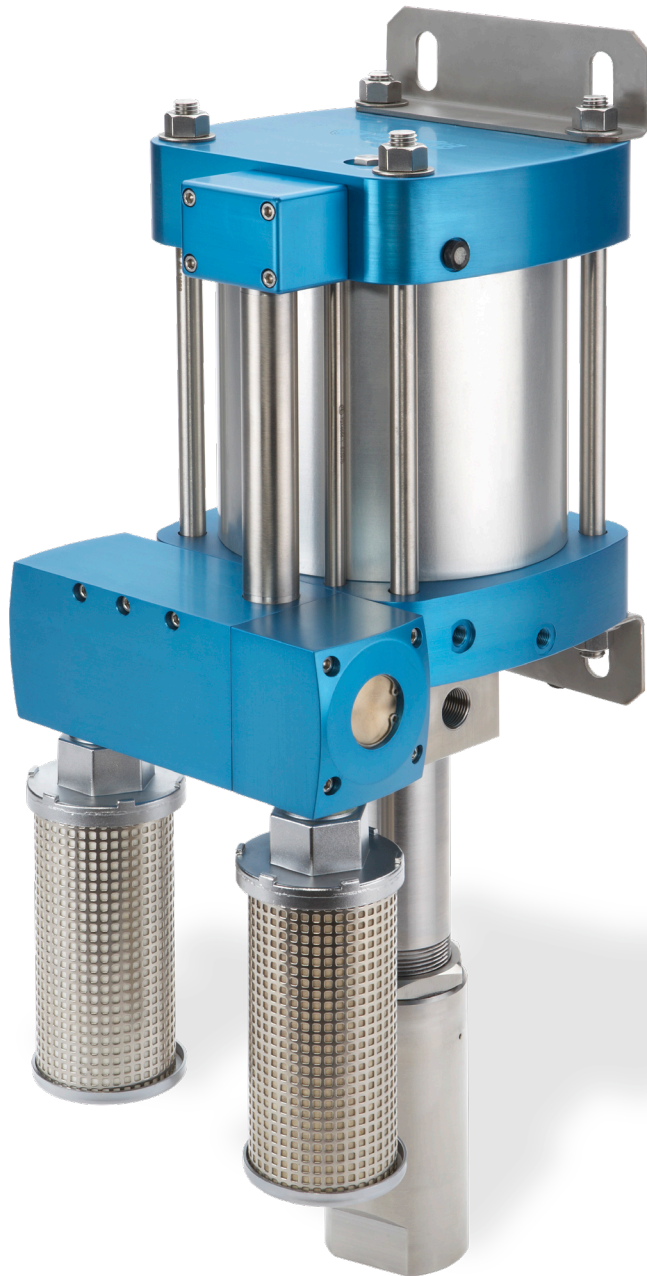

Series AFL35-1D (Double-Acting, Single Ended, Single Piston Air Drive)

Air-Driven, High Flow, High Pressure Liquid Pump

Technical & Performance Data Sheet

Manual: 02-9320BE | January 2022



ENGINEERING YOUR SUCCESS.

Technical Data

Section 1.0 Liquid Side Specifications

Service: Oil, Water or Water/Oil mixture and other fluids depending on material compatibility

Maximum Outlet Pressure: 5,600 psi (386 bar)

Air to Liquid Pressure Ratio: 1:39

Isolation Chamber: Prevents process contamination of air section - Standard

Volume Displacement Per Stroke: 6.02 in³ (98.7 cm³)

Inlet Connection: 1" NPT

Outlet Connections: Parker Autoclave F562C10-9/16" Female High Pressure

Section 2.0 Air Side Specifications

Air Drive Pressure Range: 15- 150 psi (1.0- 10 bar)* **(Note)**

Nominal Air Pressure Required: 5,600 psi (386 bar)

Output Pressure: 144 psi (9.9 bar)

Inlet Port: 3/4" FNPT

Pilot Port: 1/8" FNPT (unregulated air)

Exhaust Port (muffler removed): 1" NPT

Air Consumption @ 90 psi: 167 SCFM

Prelubricated at Factory

***Note:** Maximum air drive pressure is limited by maximum output pressure.

Section 3.0 General Specifications

Maximum Operating Temperature: 0- 140° F (-18° to 60° C)

Net Weight: 51.8 lbs. (23.5 kg)

Pressure Head: 15-5 PH Stainless Steel

Plunger Description: Stainless steel plunger utilizing a proprietary multi-layer carbon based coating with diamond like carbon exterior layer - 3 times the hardness of stellite with a coefficient of friction equal to/less than PTFE

Check Valve Glands: 316 Stainless Steel (SS)

Liquid Seal: UHMWPE U-Cup with FKM O-Rings

Air Drive Seals: Buna N



General Information

Section 4.0 - Ordering Guide

For complete information on available pump options, contact Parker Autoclave Engineers.

Typical catalog number: **AFL35-1DBCPV**

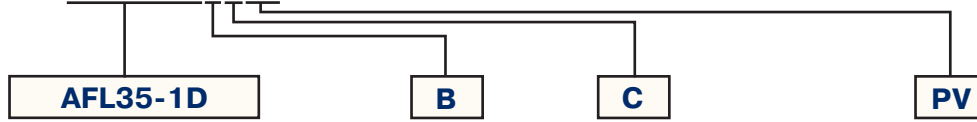

Pump Type / Size / Ratio	Liquid Inlet Location	Isolation Chamber	Liquid Seal Materials†
ASL = • High Flow, High Pressure Pump • 6" Single Piston Air Drive • 1:39 Air-to-Liquid Pressure Ratio • Maximum 5,600 psi (386 bar) • Single Ended, Double Acting Liquid Head	B = Bottom	C = Included	*PV = UHMWPE U-Cup with FKM O-Rings PB = UHMWPE U-Cup with Buna N O-rings PC = UHMWPE U-Cup with FFKM O-rings

Section 5.0 - Liquid Flow Rate vs. Outlet Pressure

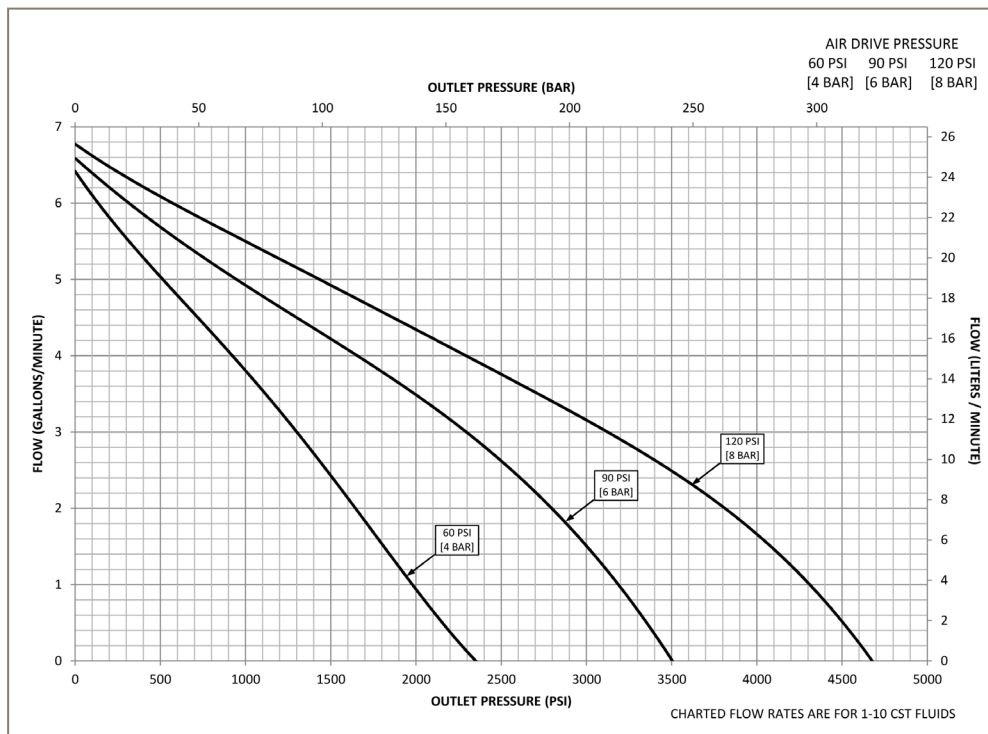

Actual flow rates will vary depending on air flow capacity, downstream flow restrictions, and fluid type.



General Information

Section 6.0 - Dimensional Data

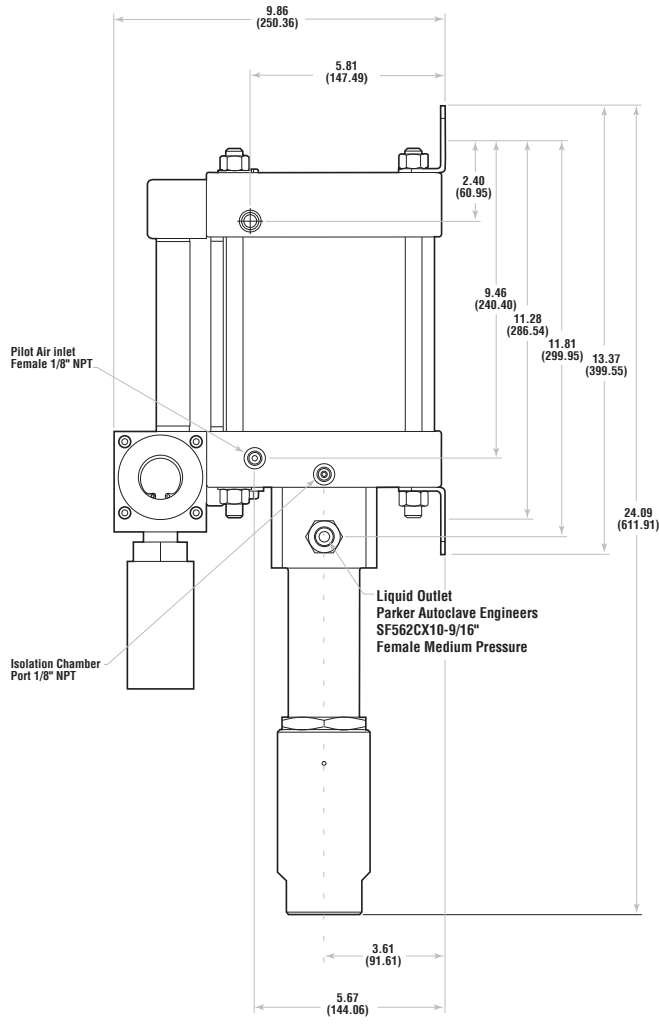

Right View

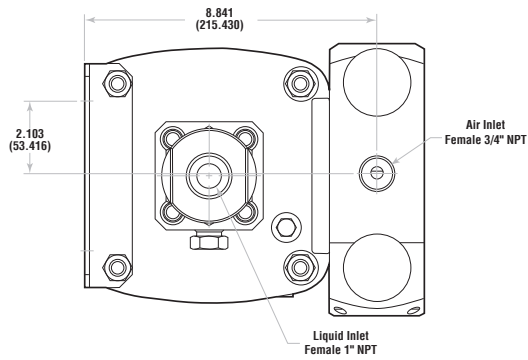

Bottom View

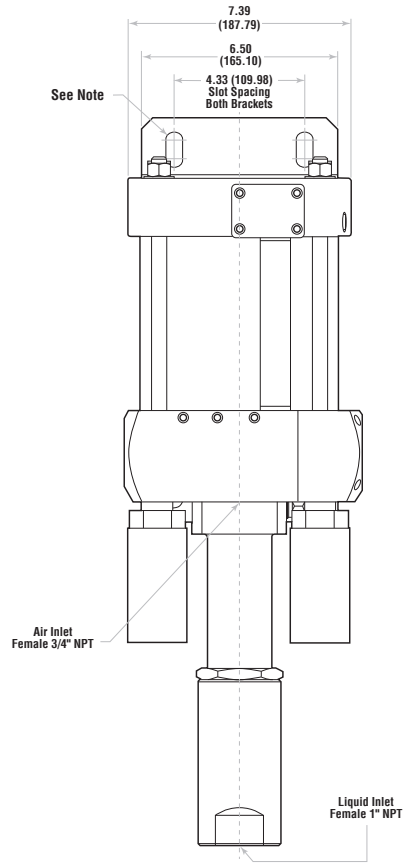

Front View

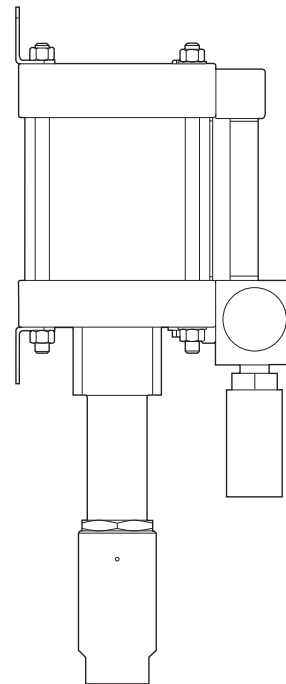

Left View

Note:

Each Mounting Bracket includes (2) 9/16" (14.29) slots for 1/2" Bolts.
 All dimensions are for reference only and are subject to change without notice.
 Primary Dimensions: Inches
 Secondary Dimensions: (Millimeters)



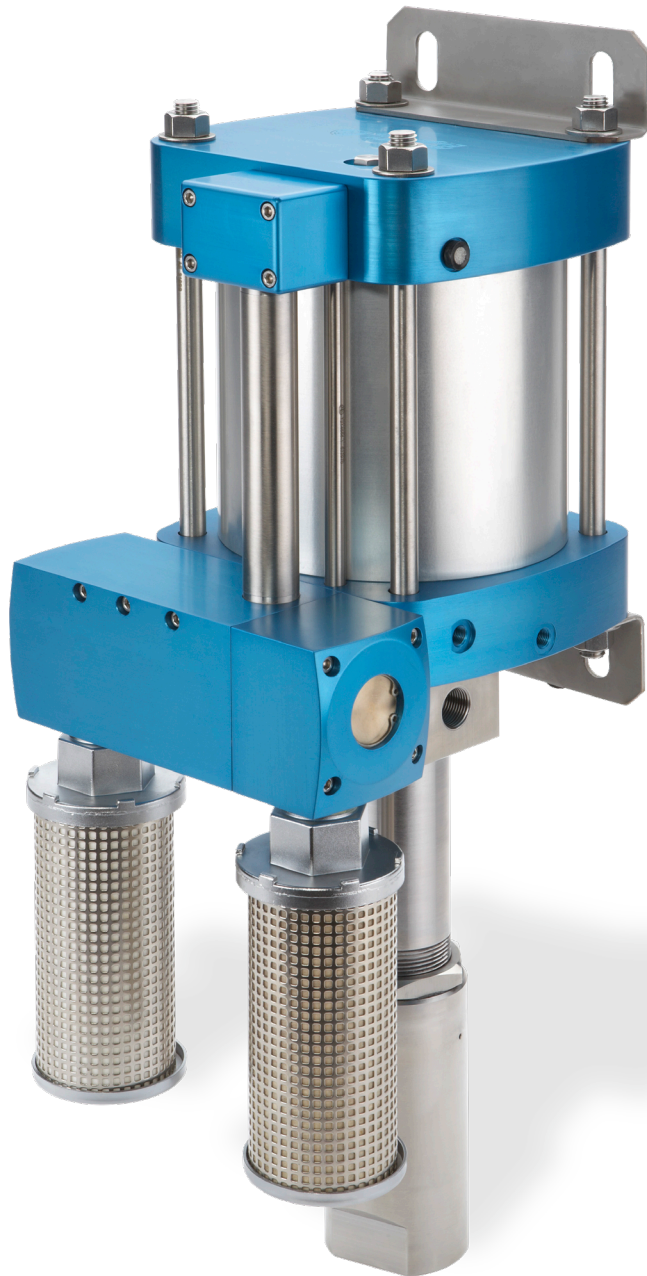

Series AFL60-1D (Double-Acting, Single Ended, Single Piston Air Drive)

Air-Driven, High Flow, High Pressure Liquid Pump

Technical & Performance Data Sheet

Manual: 02-9318BE | January 2022



ENGINEERING YOUR SUCCESS.

Technical Data

Section 1.0 Liquid Side Specifications

Service: Oil, Water or Water/Oil mixture and other fluids depending on material compatibility

Maximum Outlet Pressure: 10,000 psi (690 bar)

Air to Liquid Pressure Ratio: 1:70

Isolation Chamber: Prevents process contamination of air section - Standard

Volume Displacement Per Stroke: 3.40 in³ (55.7 cm³)

Inlet Connection: 1" NPT

Outlet Connections: Parker Autoclave F562C10-9/16" Female High Pressure

Section 2.0 Air Side Specifications

Air Drive Pressure Range: 15- 150 psi (1.0-10 bar)* **(Note)**

Nominal Air Pressure Required: 10,000 psi (690 bar)

Output Pressure: 143 psi (9.9 bar)

Inlet Port: 3/4" FNPT

Pilot Port: 1/8" FNPT (unregulated air)

Exhaust Port (muffler removed): 1" NPT

Air Consumption @ 90 psi: 167 SCFM

Prelubricated at Factory

***Note:** Maximum air drive pressure is limited by maximum output pressure.

Section 3.0 General Specifications

Maximum Operating Temperature: 0-140° F (-18° to 60° C)

Net Weight: 51.8 lbs. (23.5 kg)

Pressure Head: 15-5 PH Stainless Steel

Plunger Description: Stainless steel plunger utilizing a proprietary multi-layer carbon based coating with diamond like carbon exterior layer - 3 times the hardness of stellite with a coefficient of friction equal to/less than PTFE

Check Valve Glands: 316 Stainless Steel (SS)

Liquid Seal: UHMWPE U-Cup with FKM O-Rings

Air Drive Seals: Buna N



General Information

Section 4.0 - Ordering Guide

For complete information on available pump options, contact Parker Autoclave Engineers.

Typical catalog number: **AFL60-1DBCPV**

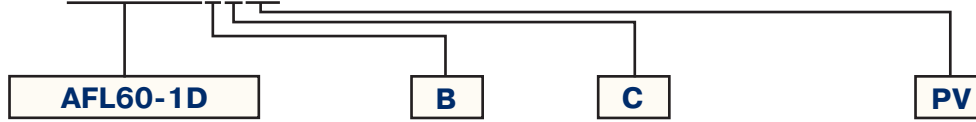

Pump Type / Size / Ratio	Liquid Inlet Location	Isolation Chamber	Liquid Seal Materials†
ASL = • High Flow, High Pressure Pump • 6" Single Piston Air Drive • 1:70 Air-to-Liquid Pressure Ratio • Maximum 10,000 psi (690 bar) • Single Ended, Double Acting Liquid Head	B = Bottom	C = Included	* PV = UHMWPE U-Cup with FKM O-Rings PB = UHMWPE U-Cup with Buna N O-rings PC = UHMWPE U-Cup with FFKM O-rings

Section 5.0 - Liquid Flow Rate vs. Outlet Pressure

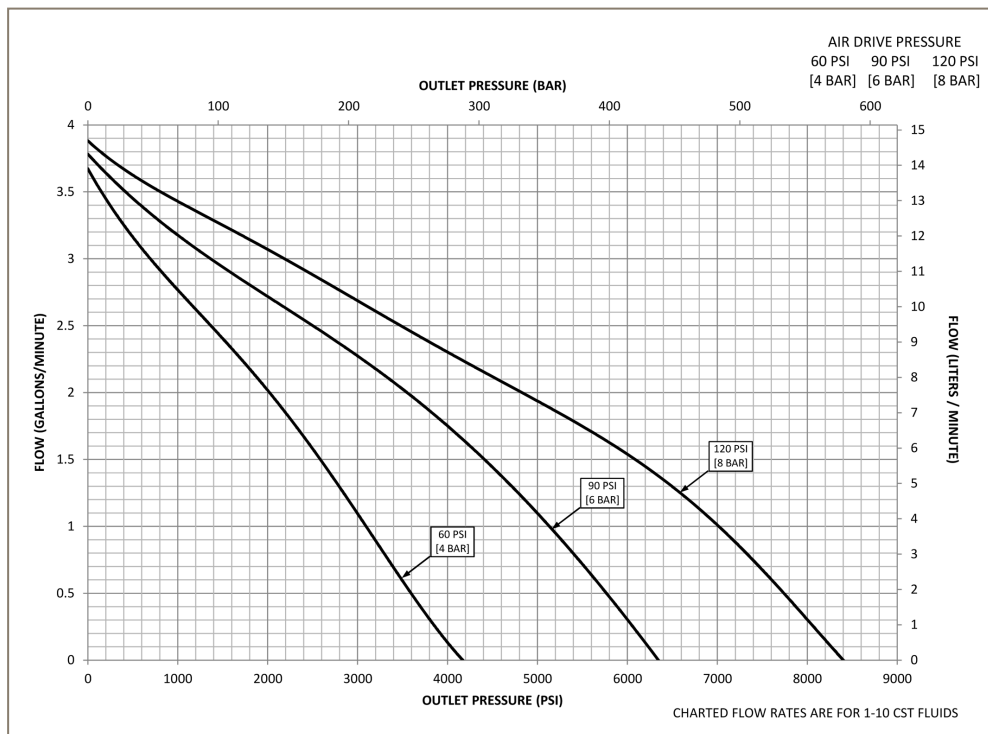

Actual flow rates will vary depending on air flow capacity, downstream flow restrictions, and fluid type.



General Information

Section 6.0 - Dimensional Data

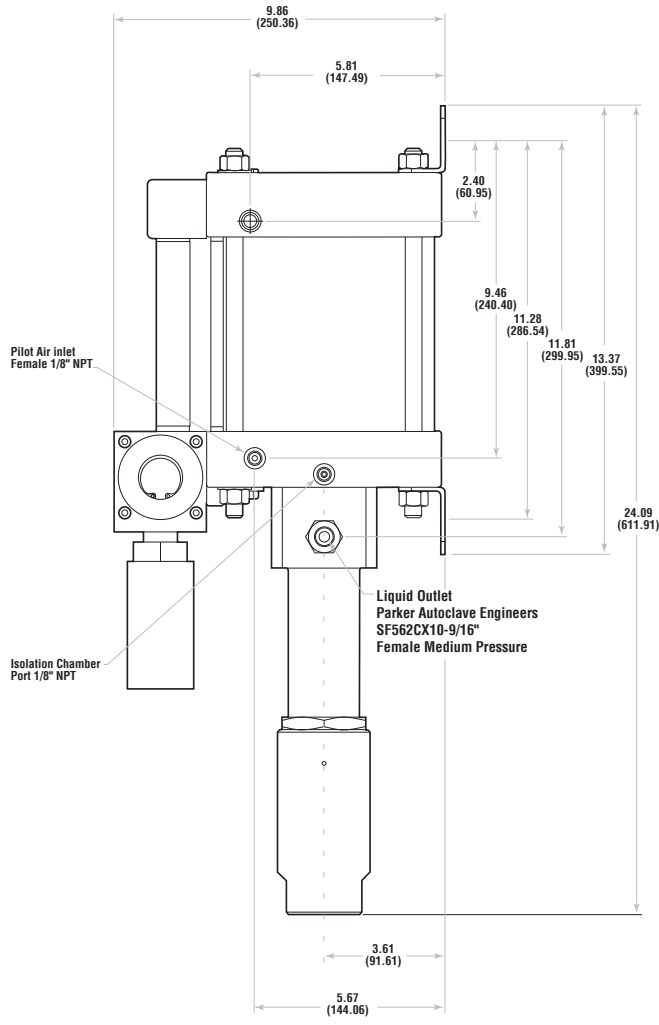

Right View

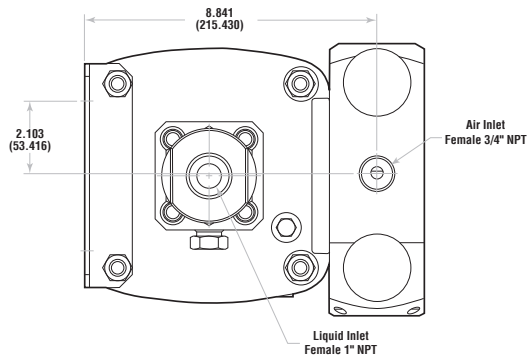

Bottom View

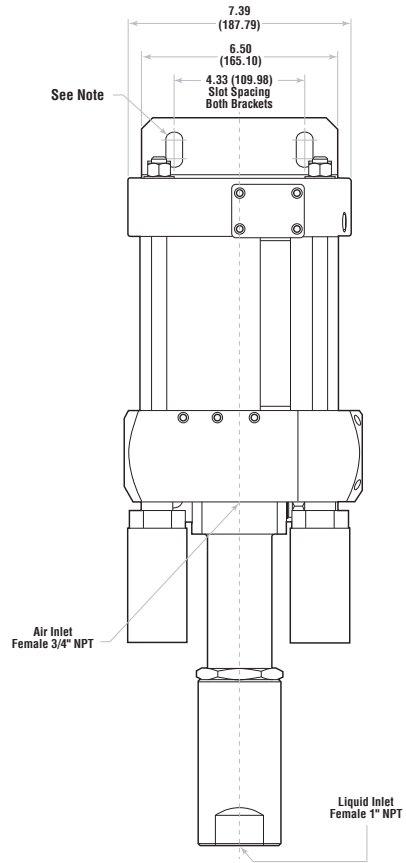

Front View

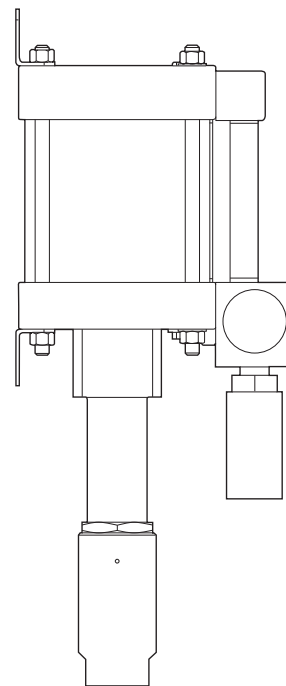

Left View

Note:

Each Mounting Bracket includes (2) 9/16" (14.29) slots for 1/2" Bolts.
 All dimensions are for reference only and are subject to change without notice.
 Primary Dimensions: Inches
 Secondary Dimensions: (Millimeters)



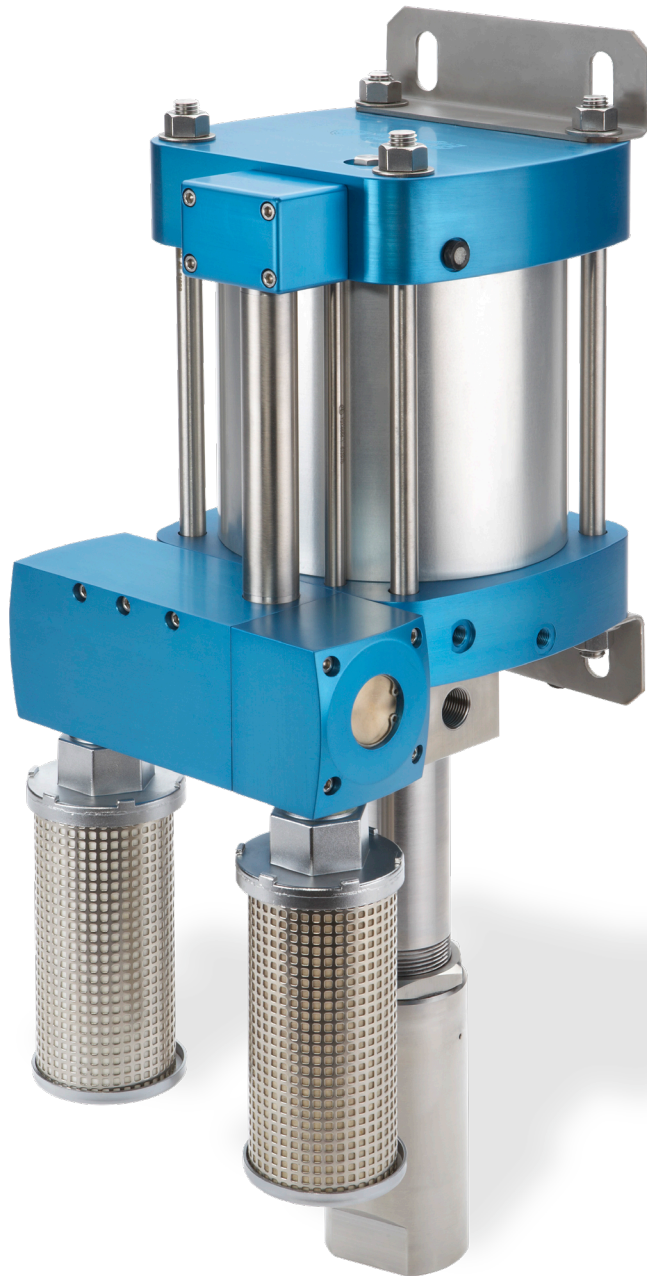

Series AFL100-1D (Double-Acting, Single Ended, Single Piston Air Drive)
Air-Driven, High Flow, High Pressure Liquid Pump
Technical & Performance Data Sheet

Manual: 02-9293BE | January 2022



ENGINEERING YOUR SUCCESS.

Technical Data

Section 1.0 Liquid Side Specifications

Service: Oil, Water or Water/Oil mixture and other fluids depending on material compatibility

Maximum Outlet Pressure: 15,000 psi (1034 bar)

Air to Liquid Pressure Ratio: 1:113

Isolation Chamber: Prevents process contamination of air section - Standard

Volume Displacement Per Stroke: 2.30 in³ (37.7 cm³)

Inlet Connection: 1" NPT

Outlet Connections: Parker Autoclave SF562CX10-9/16" Female High Pressure

Section 2.0 Air Side Specifications

Air Drive Pressure Range: 15- 150 psi (1.0-10 bar)* **(Note)**

Nominal Air Pressure Required: 15,000 psi (1034 bar)

Output Pressure: 132.75 psi (9.15 bar)

Inlet Port: 3/4" FNPT

Pilot Port: 1/8" FNPT (unregulated air)

Exhaust Port (muffler removed): 1" NPT

Air Consumption @ 90 psi: 167 SCFM

Prelubricated at Factory

***Note:** Maximum air drive pressure is limited by maximum output pressure.

Section 3.0 General Specifications

Maximum Operating Temperature: 0-140° F (-18° to 60° C)

Net Weight: 51.8 lbs. (23.5 kg)

Pressure Head: 15-5 PH Stainless Steel

Plunger Description: Stainless steel plunger utilizing a proprietary multi-layer carbon based coating with diamond like carbon exterior layer - 3 times the hardness of stellite with a coefficient of friction equal to/less than PTFE

Check Valve Glands: 316 Stainless Steel (SS)

Liquid Seal: UHMWPE U-Cup with FKM O-Rings

Air Drive Seals: Buna N



General Information

Section 4.0 - Ordering Guide

For complete information on available pump options, contact Parker Autoclave Engineers.

Typical catalog number: **AFL100-1DBCPV**

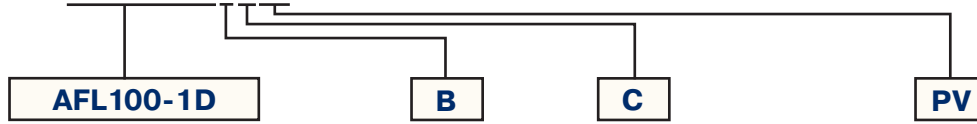

Pump Type / Size / Ratio	Liquid Inlet Location	Isolation Chamber	Liquid Seal Materials†
ASL = <ul style="list-style-type: none"> • High Flow, High Pressure Pump • 6" Single Piston Air Drive • 1:113 Air-to-Liquid Pressure Ratio • Maximum 15,000 psi (1034 bar) • Single Ended, Double Acting Liquid Head 	B = Bottom	C = Included	† PV = UHMWPE U-Cup with FKM O-Rings PB = UHMWPE U-Cup with Buna N O-rings PC = UHMWPE U-Cup with FFKM O-rings

Section 5.0 - Liquid Flow Rate vs. Outlet Pressure

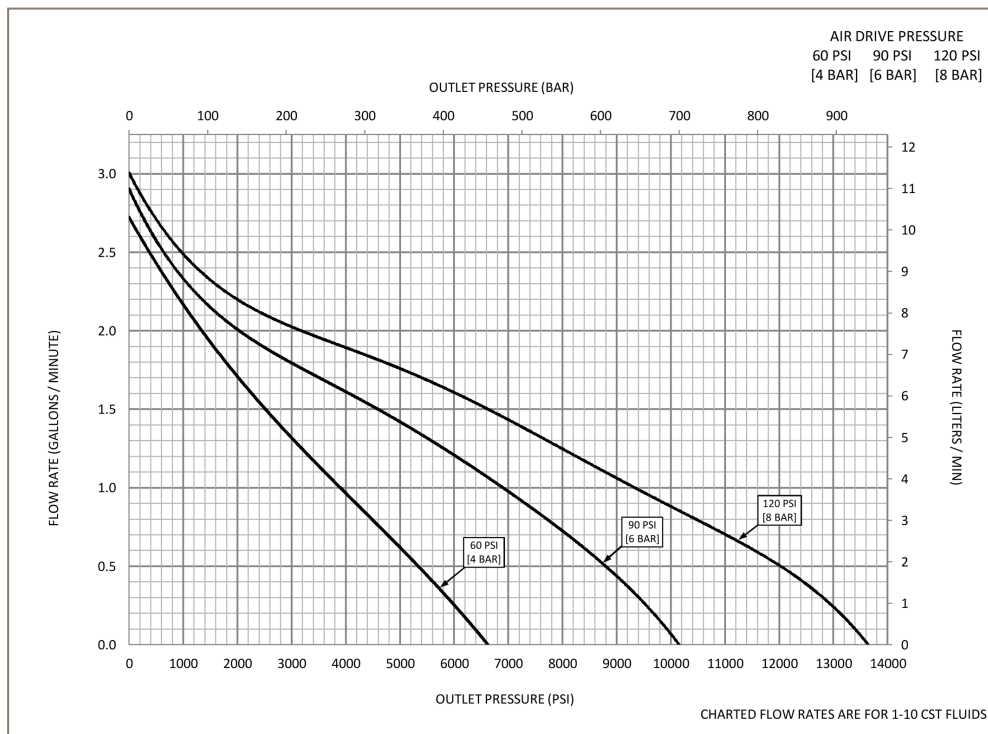

Actual flow rates will vary depending on air flow capacity, downstream flow restrictions, and fluid type.



General Information

Section 6.0 - Dimensional Data

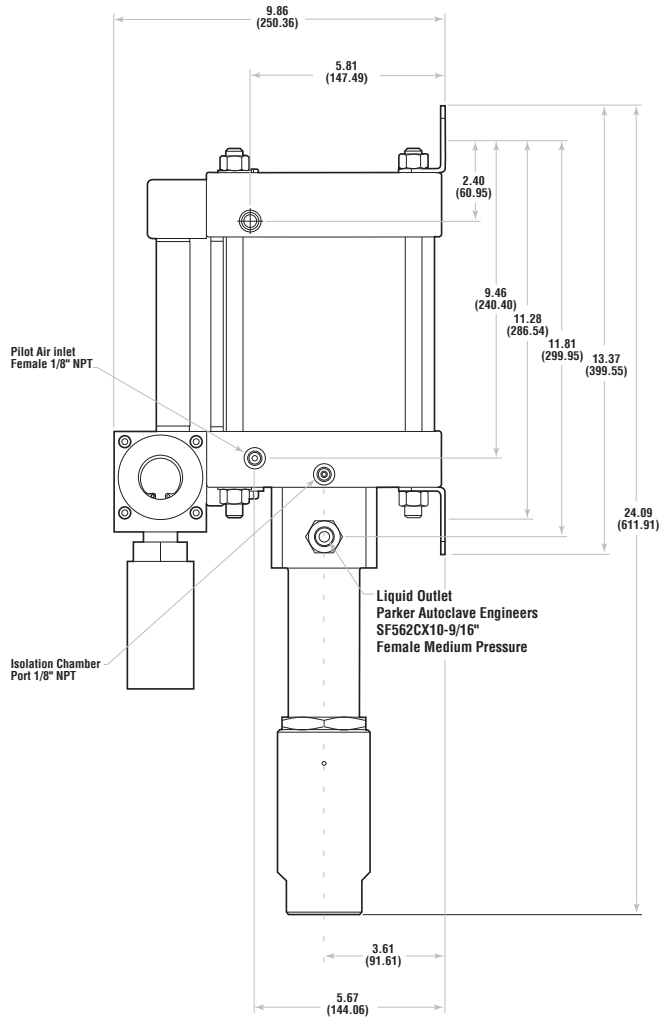

Right View

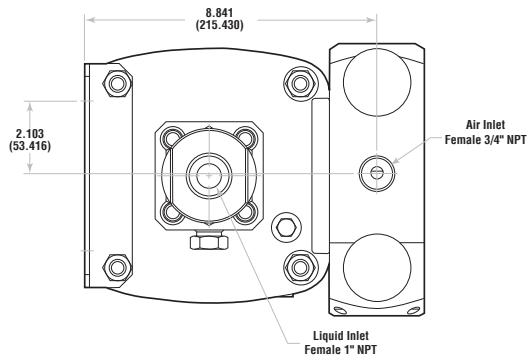

Bottom View

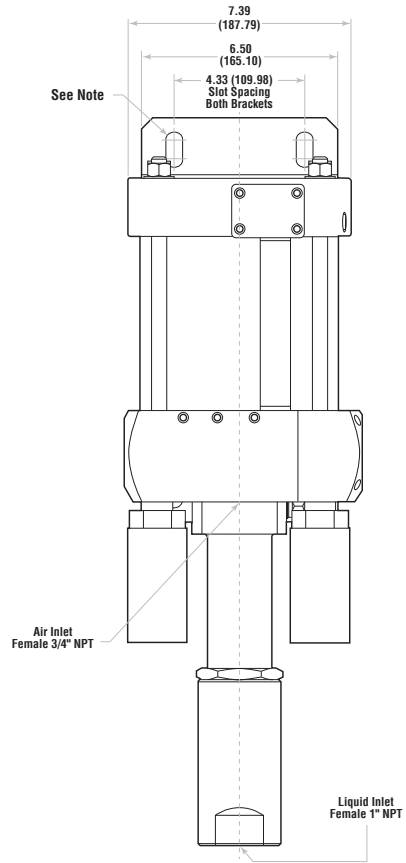

Front View

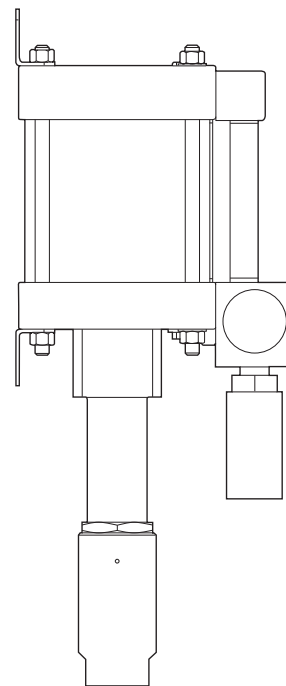

Left View

Note:

Each Mounting Bracket includes (2) 9/16" (14.29) slots for 1/2" Bolts.
 All dimensions are for reference only and are subject to change without notice.
 Primary Dimensions: Inches
 Secondary Dimensions: (Millimeters)



Parker Worldwide

North America

USA – Corporate, Cleveland, OH
Tel: +1 256 896 3000

USA – IPD, Huntsville, AL
Tel: +1 256 881 2040
ipdcct@parker.com

USA – IPD, (Autoclave), Erie, PA
Tel: +1 814 860 5700
ipdaecct@parker.com

CA – Canada, Grimsby, Ontario
Tel: +1 905-945-2274
ipd_canada@parker.com

South America

AR – Argentina, Buenos Aires
Tel: +54 3327 44 4129
falecom@parker.com

BR – Brazil, Diadema, SP
Diadema, SP
Tel: +55 11 4360 6700
falecom@parker.com

CL – Chile, Santiago
Tel: +56 (0) 2 2303 9640
falecom@parker.com

MX – Mexico, Toluca
Tel: +52 722 275 4200
contacto@parker.com

Asia Pacific

AU – Australia, Dandenong
Tel: +61 (0)2 9842 5150
customer.service.au@parker.com

CN – China, Shanghai
Tel: +86 21 2899 5000
INGtechnical.china@parker.com

HK – Hong Kong
Tel: +852 2428 8008

IN – India, Mumbai
Tel: +91 22 6513 7081-85

ID – Indonesia, Tangerang
Tel: +62 2977 7900
parker.id@parker.com

JP – Japan, Tokyo
Tel: +(81) 3 6365 4020
infophj@parker.com

KR – South Korea, Seoul
Tel: +82 2 559 0400
parkerkr@parker.com

MY – Malaysia, Selangor
Tel: +603 784 90 800
parkermy@parker.com

SG – Singapore,
Tel: +65 6887 6300
parker.sg@parker.com

TH – Thailand, Bangkok
Tel: +66 2 186 7000
phthailand@parker.com

TW – Taiwan, Taipei
Tel: +886 2 2298 8987
enquiry.taiwan@parker.com

VN – Vietnam, Hochi Minh City
Tel: +848 382 508 56
parker_viet@parker.com

Europe, Middle East, Africa

AE – UAE, Dubai
Tel: +971 4 812 7100
parker.me@parker.com

AT – Austria, Wiener Neustadt
Tel: +43 (0)2622 23501-0
parker.austria@parker.com

AT – Eastern Europe, Wiener Neustadt
Tel: +43 (0)2622 23501 900
parker.easteurope@parker.com

AZ – Azerbaijan, Baku
Tel: +994 50 2233 458
parker.azerbaijan@parker.com

BE/LU – Belgium, Nivelles
Tel: +32 (0)67 280 900
parker.belgium@parker.com

BG – Bulgaria, Sofia
Tel: +359 2 980 1344
parker.bulgaria@parker.com

BY – Belarus, Minsk
Tel: +48 (0)22 573 24 00
parker.belarus@parker.com

CH – Switzerland, Etoy
Tel: +41 (0) 21 821 87 00
parker.switzerland@parker.com

CZ – Czech Republic, Klecany
Tel: +420 284 083 111
parker.czechrepublic@parker.com

DE – Germany, Kaarst
Tel: +49 (0)2131 4016 0
parker.germany@parker.com

DK – Denmark, Ballerup
Tel: +45 43 56 04 00
parker.denmark@parker.com

ES – Spain, Madrid
Tel: +34 902 33 00 01
parker.spain@parker.com

FI – Finland, Vantaa
Tel: +358 (0)20 753 2500
parker.finland@parker.com

FR – France, Contamine s/Arve
Tel: +33 (0)4 50 25 80 25
parker.france@parker.com

GR – Greece, Athens
Tel: +30 210 933 6450
parker.greece@parker.com

HU – Hungary, Budapest
Tel: +36 223 885 470
parker.hungary@parker.com

IE – Ireland, Dublin
Tel: +353 (0)1 466 6370
parker.ireland@parker.com

IT – Italy, Corsico (MI)
Tel: +39 02 45 19 21
parker.italy@parker.com

KZ – Kazakhstan, Almaty
Tel: +7 7273 561 000
parker.easteurope@parker.com

NL – The Netherlands, Oldenzaal
Tel: +31 (0)541 585 000
parker.nl@parker.com

NO – Norway, Stavanger
Tel: +47 66 75 34 00
parker.norway@parker.com

PL – Poland, Warsaw
Tel: +48 (0)22 573 24 00
parker.poland@parker.com

PT – Portugal, Leca da Palmeira
Tel: +351 22 999 7360
parker.portugal@parker.com

RO – Romania, Bucharest
Tel: +40 21 252 1382
parker.romania@parker.com

RU – Russia, Moscow
Tel: +7 495 645-2156
parker.russia@parker.com

SE – Sweden, Spånga
Tel: +46 (0)8 59 79 50 00
parker.sweden@parker.com

SK – Slovakia, Banská Bystrica
Tel: +421 484 162 252
parker.slovakia@parker.com

SL – Slovenia, Novo Mesto
Tel: +386 7 337 6650
parker.slovenia@parker.com

TR – Turkey, Istanbul
Tel: +90 216 4997081
parker.turkey@parker.com

UA – Ukraine, Kiev
Tel: +48 (0)22 573 24 00
parker.ukraine@parker.com

UK – United Kingdom, Warwick
Tel: +44 (0)1926 317 878
parker.uk@parker.com

ZA – South Africa, Kempton Park
Tel: +27 (0)11 961 0700
parker.southafrica@parker.com



1005 A Cleaner Way
Huntsville, AL 35805 USA
Tel: 256.881.2040
Fax: 256.881.5072

www.Parker.com/IPD

8325 Hessinger Drive
Erie, PA 16509 USA
Tel: 814 860 5700
Fax: 814 860 5811

www.autoclave.com