



Bulletin MSG11-5715-734/UK

# Operation Manual Series TFP

Design ≥ 20

---

## 2-Way Servo Proportional Valves with VCD<sup>®</sup>-Technology

---

**Parker Hannifin**  
**Manufacturing Germany GmbH & Co. KG**  
Industrial Systems Division Europe  
Gutenbergstr. 38  
41564 Kaarst, Germany  
E-mail: [isde.kaarst.support@support.parker.com](mailto:isde.kaarst.support@support.parker.com)  
Copyright © 2024, Parker Hannifin Corp.



## **WARNING — USER RESPONSIBILITY**

**FAILURE OR IMPROPER SELECTION OR IMPROPER USE OF THE PRODUCTS DESCRIBED HEREIN OR RELATED ITEMS CAN CAUSE DEATH, PERSONAL INJURY AND PROPERTY DAMAGE.**

This document and other information from Parker-Hannifin Corporation, its subsidiaries and authorized distributors provide product or system options for further investigation by users having technical expertise.

The user, through its own analysis and testing, is solely responsible for making the final selection of the system and components and assuring that all performance, endurance, maintenance, safety and warning requirements of the application are met. The user must analyze all aspects of the application, follow applicable industry standards, and follow the information concerning the product in the current product catalog and in any other materials provided from Parker or its subsidiaries or authorized distributors.

To the extent that Parker or its subsidiaries or authorized distributors provide component or system options based upon data or specifications provided by the user, the user is responsible for determining that such data and specifications are suitable and sufficient for all applications and reasonably foreseeable uses of the components or systems.

Content	Page
<b>1. Introduction</b>	<b>4</b>
Characteristics of Valve Driver	4
Order Code TFP	5
Technical Data	6
Block Diagram of Integral Electronics	8
<b>2. Safety Instructions</b>	<b>9</b>
Symbols	9
Service	9
<b>3. Important Details</b>	<b>9</b>
Intended Usage	9
Common Instructions	9
Liability	9
Storage	9
<b>4. Mounting / Installation</b>	<b>9</b>
Scope of Supply	9
Available Bolts Kits	10
Mounting	10
Disassembly	10
Limits of Use	11
Pressure Fluids	11
Electrical Connection	11
Electrical Interfacing	12
<b>5. Operation Instructions</b>	<b>14</b>
Solenoid Current Monitoring	14
<b>6. Interface and Parameter</b>	<b>14</b>
IO-Link Interface	14
NFC Interface	14
ProPxD Parameterizing Software	14
Valve Parameter	15
Error Codes	17
LED Flashing Signals of the Valve Electronics	18
<b>7. Shut-off Valve TEP</b>	<b>19</b>
Position Control Switch	22
Wiring	23
Air Bleeding of Hydraulic System	24
Filter	24
Flushing	24
<b>8. Troubleshooting</b>	<b>24</b>
<b>9. Accessories / Spare Parts</b>	<b>25</b>
Accessories	25
Spare Parts	25

## Operation Manual

### 1. Introduction

Parker 2-way servo proportional valves with VCD technology have an integrated electronics and require only one sole electrical common for the control system.

The TFP\*B series is based on the TFP\*A series and has a directional control valve, with position control, for shutting off the pilot valve.

### Characteristics of Valve Driver

The described integral electronic driver combines all necessary functions for the optimal operation of the valves. Thanks to its excellent dynamic the valves are usable within closed loop control applications. The most important features are:

- high dynamic actuator principle with special designed electronic driver
- closed loop controlled spool position
- constant current actuator control with overcurrent shutoff
- excellent properties for response sensitivity and temperature drift
- differential input stage with various command signal options
- diagnostic output for spool stroke
- standard central connection
- compatible to the relevant European EMC-standards

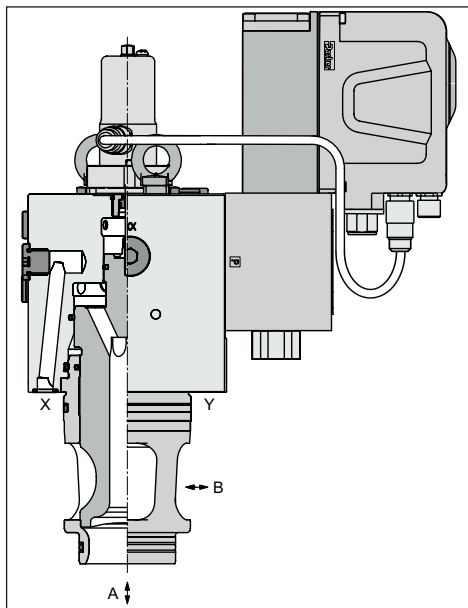

TFP050

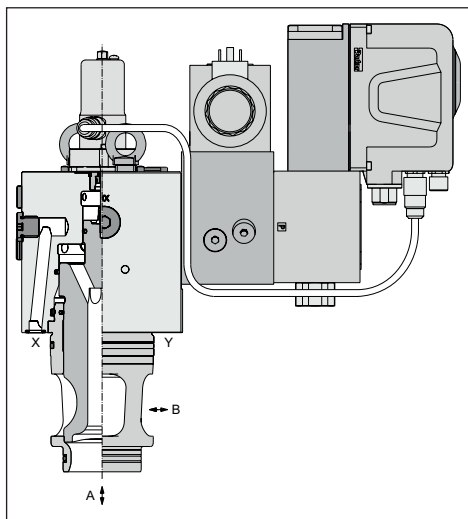

TFP050\*B



## Operation Manual

### Ordering Code

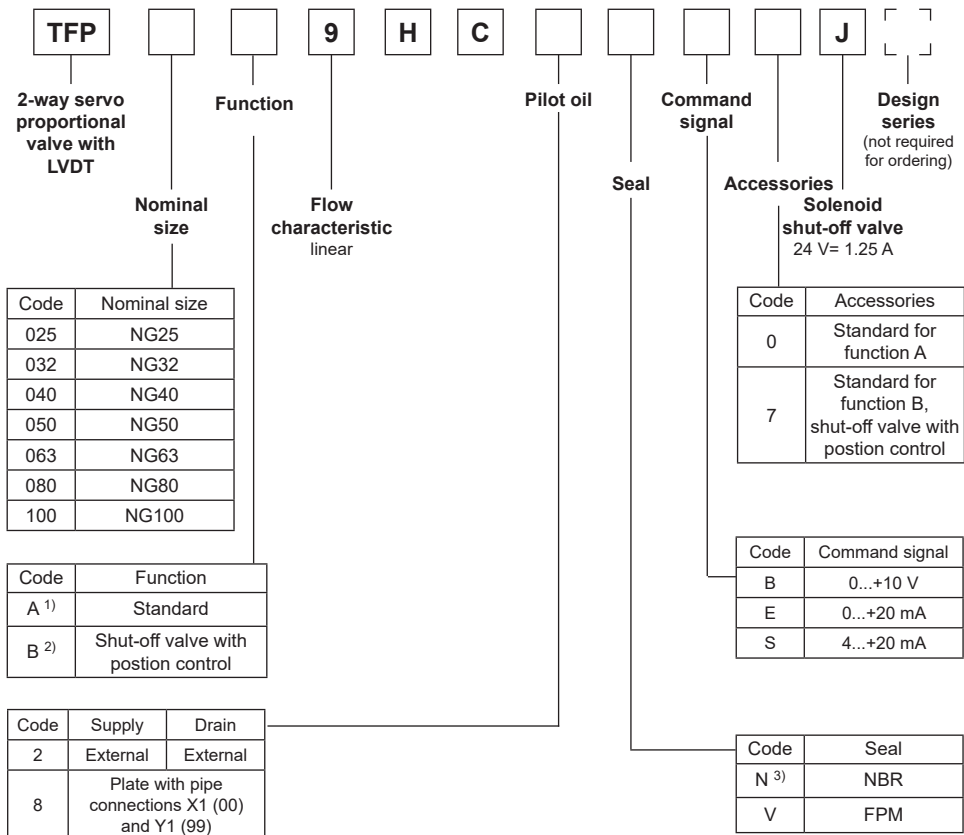

Note : Please order connector separately

<sup>1)</sup> For accessories code 0.

<sup>2)</sup> For accessories code 7.

<sup>3)</sup> HFC fluids suitable.

### Technical Data

General								
Design	Proportional throttle valve with LVDT and integrated electronics, slip-in cartridge according to ISO 7368							
Nominal size	DIN	<b>NG25</b>	<b>NG32</b>	<b>NG40</b>	<b>NG50</b>	<b>NG63</b>	<b>NG80</b>	<b>NG100</b>
Mounting position	unrestricted							
Ambient temperature	[°C]	-20...+60						
Weight	[kg]	9	11	21	28	42	77	122
Vibration resistance	[g]	10 sinus 5...2000 Hz acc. IEC 60068-2-6 10 (RMS) random noise 20...2000 Hz acc. IEC 60068-2-64 15 shock acc. IEC 60068-2-27						
Hydraulic								
Max. operating pressure	[bar]	Ports A, B, SP max. 420, X max. 350; XX observe accumulator pressure rating; port Y max. 35						
Fluid	Hydraulic oil according to DIN 51524							
Fluid temperature	[°C]	-20...+60 (NBR: -25...+60)						
Viscosity, recommended	[cSt]/	30 ... 80						
permitted	[cSt]/	20 ... 400						
Filtration								
Nominal flow at $\Delta p = 5$ bar (linear)	[l/min]	650	1200	1800	3100	5200	7600	11100
Max. flow ( $v = 30$ m/s), recommended (linear)	[l/min]	1400	2600	4100	6200	9800	17000	25000
Flow direction	B to A / A to B							
Pilot pressure	[bar]	max. 350						
Pilot oil Supply	external via X							
Drain	external via Y							
Leakage in pilot valve at 100 bar	[ml/min]	< 400						
Pilot valve size	<b>NG06</b>				<b>NG10</b>			
Max. pilot flow at 140 bar pilot pressure	[l/min]	21	33	37	54	71	86	105
Pilot pressure, recommended	Pilot pressure $p_x =$ system pressure $p_s$							
Minimum pilot pressure $p_{min}^{1)}$	[bar]	140						
Static/dynamic								
(for optimal dynamics see installation recommendation)								
Step response at pilot press. >140 bar	[ms]	9	11	13	12	15	20	26
Frequency response at pilot pressure >140 bar	[Hz]	on request						
Hysteresis	[%]	< 0.1						
Sensitivity	[%]	< 0.05						
Temperature drift	[%/K]	< 0.025						

### Installation recommendations

The maximum pilot flow is given in the technical data. At insufficient pilot oil supply – e.g. because of long distances and/or small diameters – an accumulator can be connected to port XX.

To avoid this, an accumulator can be connected to port XX at the valve body of the TFP (not for nominal size NG25). A short-term undersupply with pilot oil can be compensated via this accumulator.

The required accumulator size is dependent on the pilot oil pressure.

Please also consider the Parker accumulator product range and the Parker Accumulator Sizing Software.

Nominal size	Required accumulator volume [l]	
	1 stroke (close)	2 stroke (close and open)
NG25	0.005	0.010
NG32	0.008	0.016
NG40	0.010	0.020
NG50	0.015	0.03
NG63	0.02	0.04
NG80	0.035	0.07
NG100	0.05	0.1

<sup>1)</sup> If valves with onboard electronics are used in safety-related parts of control systems, in case the safety function is requested, the valve electronics voltage supply is to be switched off by a suitable switching element with sufficient reliability.

Technical Data

Interfaces		
IO-Link		IEC 61131-9
NFC		ISO/IEC 15693 • NFC Forum Type 5 tag certified by the NFC Forum Frequency 13.56 MHz; -27.2 dBμA/m at 10 distances
Electrical characteristics		
Duty ratio	[%]	100
Protection class		IP65 in accordance with EN 60529 (with correctly mounted plug-in connector) 6 = Full protection against contact, dust tight 5 = Protection against water jets (nozzle) from any angle
Supply voltage/ripple	[V]	24 nominal (tolerance range 22 ... 30), electric shut-off at < 19, ripple < 5 % eff., surge free
Current consumption max.	[A]	3.5
Pre-fusing	[A]	4.0 medium lag
Input signal		
Code B	Voltage [V]	10...0...-10, ripple <0.01 % eff., surge free
	Impedance [kOhm]	100
Code E	Current [mA]	20...0...-20, ripple <0.01 % eff., surge free
	Impedance [Ohm]	<250
Code S	Current [mA]	4...12...20, ripple <0.01 % eff., surge free <3.6 mA = disable, >3.8 mA = according to NAMUR NE43
	Impedance [Ohm]	<250
Differential input max.	[V]	30 for terminal D and E against PE (terminal G) 11 for terminal D and E against 0V (terminal B)
Enable signal		acc. EN 61131-2; Type 3
	[V]	Low -3...+5; High 11...30; input current 3 mA
Diagnostic signal	[V]	+10...0...-10
EMC		EN 61000-6-2, EN 61000-6-4
Electrical connection		6 + PE acc. EN 175201-804
Wiring min.	[mm <sup>2</sup> ]	7 x 1.0 (AWG16) overall braid shield
Wiring length max.	[m]	50

Block Diagram of Integrated Electronics

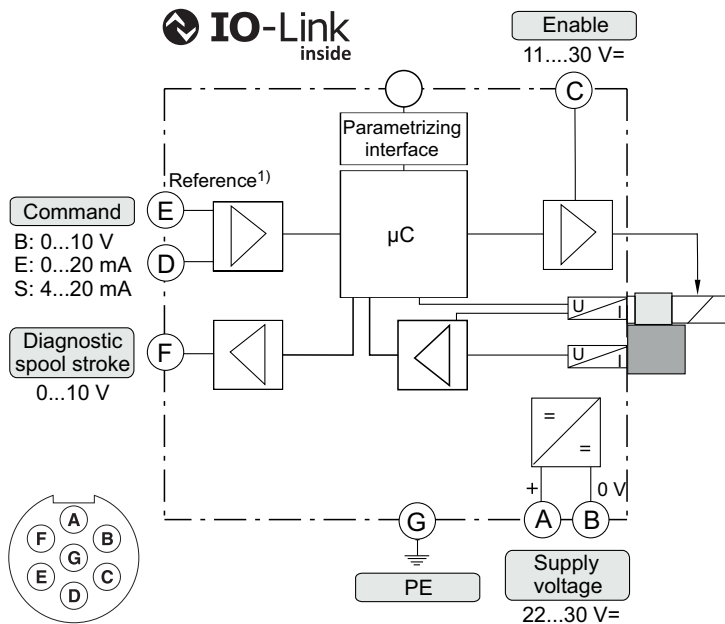

<sup>1)</sup> Do not connect with the supply voltage zero.

Pin assignment IO-Link (parametrizing) interface, M12 socket

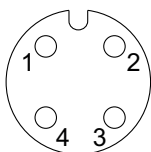

PIN assignment acc. IEC 60974-5-2

- Pin 1: 24 VDC
- Pin 3: GND
- Pin 4: IO-Link Communication (C/Q)

# Operation Manual

## 2. Safety Instructions

Please read the operation manual before installation, startup, service, repair or stocking! Paying no attention may result in damaging the valve or incorporated system parts.

### Symbols

This manual uses symbols which have to be followed accordingly:



**Instructions with regard to the warranty**



**Instructions with regard to possible damaging of the valve or linked system components**



**Helpful additional instructions**

### Service

Workings in the area of installation, commissioning, maintenance and repair of the valve may only be allowed by qualified personnel. This means persons which have, because of education, experience and instruction, sufficient knowledge on relevant directives and approved technical rules.

## 3. Important Details

### Intended Usage

This operation manual is valid for 2-way high-response valves series TFP. Any different or beyond it usage is deemed to be as not intended. The manufacturer is not liable for warranty claims resulting from this.

### Common Instructions

We reserve the right for technical modifications of the described product. Illustrations and drawings within this manual are simplified representations. Due to further development, improvement and modification of the product the illustrations might not match precisely with the described valve. The technical specifications and dimensions are not binding. No claim may result out of it. Copyrights are reserved.

### Liability

The manufacturer does not assume liability for damage due to the following failures:

- incorrect mounting / installation
- improper handling
- lack of maintenance
- operation outside the specifications



Do not disassemble the valve! In case of suspicion for a defect please contact Parker.

### Storage

In case of temporary storage the valve must be protected against contamination, atmospheric exposure and mechanical damages. Each valve has been factory tested with hydraulic oil, resulting in protection of the core parts against corrosion. Yet this protection is only ensured under the following conditions:

Storage period	Storage requirements
12 months	constant humidity < 60 % as well as constant temperature < 25 °C
6 months	varying humidity as well as varying temperature < 35 °C



Outdoor storage or within sea and tropical climate will lead to corrosion and might disable the valve!

## 4. Mounting / Installation

### Scope of Supply

Please check immediately after receiving the valve, if the content is matching with the specified scope of supply. The delivery includes:

- valve
- operation manual

The central connector has to be ordered separately and is not included in the delivery.



Please check the delivery immediately after receiving the shipment for apparent damages due to shipping. Report shipment losses at once to the carrier and the supplier!

## Available Bolt Kits

Size	Ordering no.	Mounting bolt	Torque
TFP025	BK504	4 pcs. M12x100	108 Nm
TFP032	BK529	4 pcs. M16x100	264 Nm
TFP040	BK481	4 pcs. M20x110	517 Nm
TFP050	BK544	4 pcs. M20x130	517 Nm
TFP063	BK545	4 pcs. M30x140	1775 Nm
TFP080	BK546	8 pcs. M24x200	890 Nm
TFP100	BK547	8 pcs. M30x220	1775 Nm

## Mounting

- Compare valve type (located on the name plate) with part list resp. circuit diagram.
  - The valve may be mounted fix or movable in any direction.
  - Verify the mounting surface for the valve. Unevenness of 0.01 mm/100 mm, surface finish of 6.3 µm are tolerable values.
  - ☞ Keep valve mounting surface and work environment clean!
  - Remove protection plate from the valve mounting surface
  - Check the proper position of the valve ports and the O-rings.
  - Mounting bolts: use property class 12.9, ISO 4762
- ⚠ Insufficient condition of the valve mounting surface might create malfunction! Incorrect mounting resp. bolt torque may result in abrupt leakage of hydraulic fluid on the valve ports.
- ⚠ Y-port has always to be tied directly and separately to tank!

## Disassembly

Use of disassembly aid (from nominal size NG50)

First loosen the two fixing screws without disassembly aid. Then loosen the two socket screws SW6 (TFP050: the two ring bolts) with the disassembly aids and turn the straps 90° against the

stop. Fix the socket screws/ring bolts again. Now loosen the two remaining fixing screws alternately. By turning them against the straps, the valve is pulled out of the cavity.

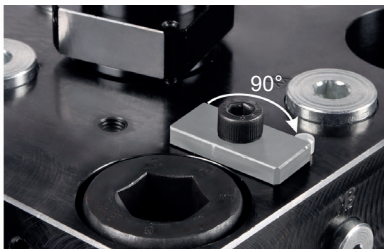

## Operation Manual

### Limits of Use

The valve may be operated within the determined limits only. Please refer to the "technical data" section as well as to the "characteristic curves" in the Parker catalogue MSG11-3500/UK "Hydraulic Valves Industrial Standard".



Follow the environmental conditions! Unallowable temperatures, shock load, aggressive chemicals exposure, radiation exposure, illegal electromagnetic emissions may result in operating trouble and may lead to failure! Follow the operating limits listed in the "specifications" table!

### Pressure Fluids

The following rules applies for the operation with various pressure fluids:



This information serves for orientation and does not substitute user tests among the particular operating conditions. Particularly no liability for media compatibility may be derived out of it.

Mineral oil: usable without restriction.

HFC: Choose seal option code N.

For operation with the following pressure fluids please consult Parker:

HFA	Oil-in-water emulsion
HFB	Water-in-oil emulsion
HFD	Unhydrous fluids (Phosphor-Ester)



For detailed information concerning pressure fluids note VDMA-document 24317 as well as DIN 51524 & 51502.

Special gaskets may be available depending on the utilized fluid.

In case of doubt please consult Parker.

### Electrical Connection

The electrical connection of the valve takes place by one common cable, which is coupled to the integrated electronic driver by a central connector assembly.

The connection requires a 6 + PE female connector EN 175201-804.

Female connector (ordering no. 5004072)

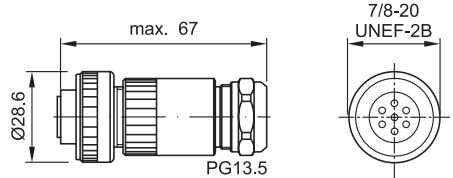

A female connector with metal housing is required! Plastic made models may create function problems due to insufficient EMC-characteristics.



Do not disconnect cable socket under tension!

The connecting cable has to comply to the following specification:

Cable type	control cable, flexible, 7 conductors, overall braid shield
Cross section	min. AWG16
Outer dimension	8...12 mm
Cable length	max. 50 m



For cable lengths > 50 m consult Parker.

The connection cable is coupled to the female connector by solder joints.

Skinning lengths for the connecting cable:

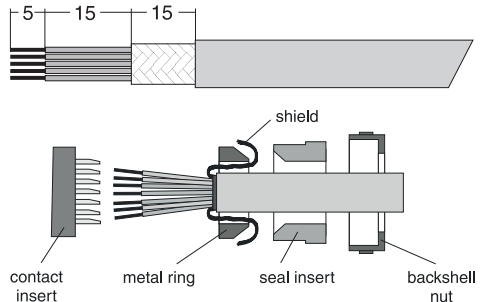

The backshell nut of the cable gland has to be tightened with a suitable tool. The target value for the tightening torque is 4 Nm. Tighten the cap nut with a torque of 5 Nm after attaching the female connector on the socket.

**⚠** Incomplete tightening of backshell nut respectively cap nut may result in undesired release of the connection as well as degradation of the water tightness.

When using female connectors of other manufacturers, the relevant regulations must be observed.

**⚠** The cable may only be connected to the female connector by authorized and qualified personnel. A short between individual conductors resp. to the connector housing, bad soldering as well as improper shield connection may result in malfunction and breakdown of the valve.

**⚠** The mounting surface of the valve has to be connected to the earth grounded machine frame. The earth ground wire from the valve connecting cable as well as the cable shield have to be tied to the protective earth terminal within the control unit. It is necessary to use a low ohmic potential connection between control unit and machine frame to prevent earth loops (cross section AWG 6).

## Electrical Interfacing

### Supply Voltage

The supply voltage for the valve has to cover the range of 22...30 V. Valve is de-energized below 19 V. The residual ripple may not exceed 5 % eff.

**⚠** The applied power supply must comply to the relevant regulations (DIN EN 61558) and must carry a CE-mark. The operating voltage for the valve must be free of inductive surges. Do not exceed the max. value of 30 V! Higher voltage can lead to failure of the valve.

**⚠** The increased inrush current of the valve should be considered when selecting the power supply. A stabilized power supply with overcurrent limiting feature should not be used. Due to the inrush current of the valve the current limit circuit may respond prematurely and create problems during energizing of the supply voltage.

**⚠** The operation of the valve is blocked if the supply voltage polarity is interchanged.

**⚠** Each valve requires a separate pre-fuse of 4 Amp semi time-lag. Failure to observe this instruction may create irreparable damage of valve respectively incorporated system parts.

## Wiring Diagram of Supply Voltage

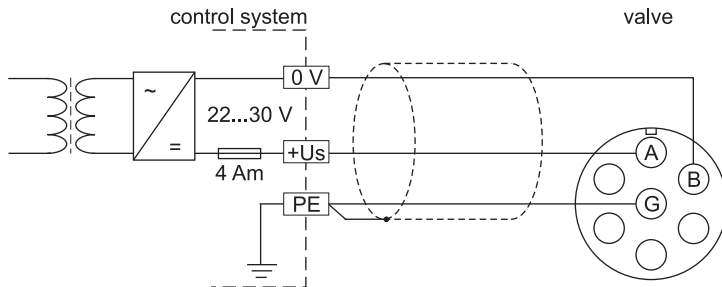

## Operation Manual

### Enable Input

A signal voltage enables the actuator drive of the valve. Continuous operation of the valve requires a permanent voltage 11...30 V (i.e. the supply voltage). In case of disabling the signal the valve will reach its power down position spring-actuated independently from the command signal value.

 The enable function represents no safety arrangement against unwanted valve operation in terms of rules for accident prevention!

 The option 4...20 mA uses the “3.6 mA” condition as breakdown-information. If the input signal line is interrupted, an evaluable failure information is available. In this case the actuator drive will be switched off. The drive will switch on when the input signal reaches a value of 3.8 mA, it switches off when the command falls below 3.6 mA. This determination follows the NAMUR-specification NE43.

### Command Signal Input

The spool stroke behaves proportional to the command signal amplitude.

 The command input signal needs to be filtered as well as free of inductive surges and modulations. Due to the sensitivity of the valve a high signal quality is recommended, this will prevent malfunction.

### Diagnostics Output

A diagnostics signal is available. Its voltage represents the operating condition of the valve.

 The output may drive a load of max. 5 mA. Exceeding of this limit leads to malfunction.

### Valves NG25 to NG100

Code command signal	Command signal	VCD actuator	Diagnostic signal
B	0...+10 V	on	0...-10 V
	0...-10 V	on	0...+10 V
	Overload	off	Red LED
E	0...+20 mA	on	0...-10 V
	0...-20 mA	on	0...+10 V
	Overload	off	Red LED
S	4...12 mA	on	0...+10 V
	12...20 mA	on	0...-10 V
	0...3.6 mA	off	Cable break, red LED
	Overload	off	Red LED

 A valve fault can be recognised by the signal colour of the 360° LED (page 18). Error and error type can be read out via the ProPXD software or the IO-Link connection.

- Parameter list Page 15
- Error code list Page 17

## Operation Manual

### 5. Operating Instructions

#### Spool Position at Power Down/Center Position



For valves with zero lap spools, distinction must be made between hydraulic neutral position and power-down position. Neutral position is taken at neutral input signal, corresponding to zero position of the hydraulic symbol. When the valve is switched off – no supply voltage, no enable, current signal (code S) < 3,8 mA – zero lap valves take the power down position (approximately 10 % opening) according to the ordering code. For valves with overlap spools, neutral position and power down position are the same (zero position).



Supply pressure must be ensured before valve is energized.

#### Solenoid Current Monitoring

If the actuator current time interval exceeds 10 seconds, the actuator is switched off to prevent overheating. For normal operating conditions this state will not be reached, but it may occur with a contaminated sluggish valve.



In this case the reason for the contamination should be rectified (hydraulic fluid exchange, filtration review, valve flushing).

The overcurrent shutoff condition may be reset by the actions below:

Code 0: Temporary disconnection of the supply voltage.

Code 5: Temporary disconnection of the enable signal.

Code 7: Temporary disconnection of the enable signal.



The shutoff of the VCD actuator due to overload will be indicated via the LED.

#### Temperature monitoring

The proportional directional control valves have internal temperature monitoring of the valve electronics.



When an overtemperature is reached, the valve switches off automatically. A restart is only possible again when the temperature of the valve electronics is within the operating temperature range.

### 6. Interface and Parameter

#### IO-Link Interface

IO-Link communication takes place via the externally accessible M12 interface.

The IO-Link interface allows an external access to the available valve parameters via an IO-Link master or via the ProPxD software.

Parker IO-LINK MASTER USB order no. 40983544 (Parameter overview in the operating instructions)

#### NFC Interface

The NFC interface allows a wireless access to valve data via the Parker App PDC (available free of charge in the **App Store** and **Google Play Store**). NFC communication may only be used for maintenance purposes by trained personnel.



The valve may have hot surfaces. There is a risk of burn injury. Before using NFC radio communication, ensure that the valve has cooled down sufficiently.

#### ProPxD Parameterizing Software

The ProPxD software allows quick and easy setting of the digital valve electronics. Individual parameters as well as complete settings can be viewed, changed and saved via the comfortable user interface. Parameter sets saved in the non-volatile memory can be loaded to other valves of the same type or saved for documentation purposes.

The PC software can be downloaded free of charge at [www.parker.com/isde](http://www.parker.com/isde) – see page “Support” or directly at [www.parker.com/propxd](http://www.parker.com/propxd).

(IO-Link Master USB is required)

#### IO-Link interface

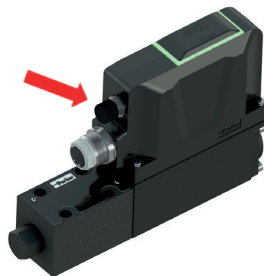

## Valve Parameter - read + write

Please note: Certain combinations of parameters can lead to inappropriate reactions in the application.

Parameter	Function	Description	Unit	Parameter range		Default settings	Note
				from	to		
24	CUSTOMER - Specification application Tag	Specification of the application					
25	CUSTOMER - Function Tag	Description of the function					
26	CUSTOMER - Location Tag	Location of the application					
96	Device Local	Indicates the source of the control word acting on the device state machine					
97	Device Mode	Device mode					
100	Hold Setpoint	Internal setpoint in device state HOLD					
101	Enable Behavior	Determines enable/disable reaction of state machine					
256	Command signal Type	Selection of the analog command signal type					"Command W read + write"
257	Scaling command signal	"Adjustment of the command signal option. To match the command signal input to the input signal mode."					
258	Command Signal Analog Cable Break	"Analog command signal cable break detection only for 4-20 mA"					
264	Diagnose A Output Signal Type	Set the diagnose output A signal type					
265	Diagnose B Output Signal Type	Set the diagnose output B signal type					
268	Diagnose A Measuring Point	Diagnose A measuring point					
269	Diagnose B Measuring Point	Diagnose B measuring point					
276	Zero adjust	Adjustment of zero position shifting (offset).	%	-90	90	0	
277	MIN Overlap Comp On/Off	To compensate asymmetries.					
278	MIN A-Channel	"Adjustment of stroke step for valve side A at min. operating threshold. To compensate for the overlap of the valve spool."	%	0	50	depending on valve	
279	MIN B-Channel	"Adjustment of stroke step for valve side B at min. operating threshold. To compensate for the overlap of the valve spool."	%	0	50	depending on valve	
280	MAX A-Channel	"Adjustment of maximum signal span for positive output signal. To match the command signal span to the valve operating range."	%	50	100	depending on valve	
281	MAX B-Channel	"Adjustment of maximum signal span for negative output signal. To match the command signal span to the valve operating range."	%	50	100	depending on valve	
284	Ramp Type	Selection of the ramp type	-				
285	Ramp Up Time Quadrant I	Ramp increasing rate for quadrant I	ms	0	32500	0	
286	Ramp Down Time Quadrant I	Ramp decreasing rate for quadrant I	ms	0	32500	0	
289	Ramp Up Time Quadrant III	Ramp increasing rate for quadrant III	ms	0	32500	0	
290	Ramp Down Time Quadrant III	Ramp decreasing rate for quadrant III	ms	0	32500	0	
295	LED Ring On Off	On/Off LED ring	-				
768	Validate Error Reaction Type	Set reaction type of the chosen error	-				
769	Validate Error Code	Chosen error to validate	-				

## Operation Manual

### Valve Parameter - read only

Parameter	Function	Description	Unit
16	Vendor Name	PARKER	
19	Part no.	Part number	
20	Product description	Product description with design stage	
21	Serial number	PTS code	
23	Firmware Revision	Firmware revision number	
32	Error Counter	Number of error	
36	Device Status	Device Status OK or not OK	
67	Elektronik hardware version	Hardware identification	
86	Checksum Active Parameter Setting	Checksum over active parameters (user changed)	
64	Valve Type	Valve family	
770	Validate Error Counter	Number of occurred errors of the chosen error	
800	Operating Time Days	Daily counter in which the device is in operation	day
801	Operating Time Hours	Hour counter in which the device is in operation	hour
802	Operating Time Minutes	Minute counter in which the device is in operation	minutes
805	On Off Cycles	Counter how often the device was switched on off	
810	Device Supply Voltage Actual	Actual applied supply voltage of the device	V
811	Device Supply Voltage Max	Maximum applied supply voltage of the device	V
812	Device Supply Voltage Avg	Average supply voltage of the device	V
813	Device Current Actual	Actual current consumption that occurred on the device	A
814	Device Current Max	Maximum current consumption that occurred on the device	A
815	Device Current Avg	Average current consumption of the device	A
816	Device Power Actual	Actual power consumption that occurred on the device	W
817	Device Power Max	Maximum power consumption that occurred on the device	W
818	Device Power Avg	Average power consumption of the device	W
831	Temperature In electronic box Actual	Actual temperature that occurred in electronic box	°C
832	Temperature In electronic box Min	Minimum temperature that occurred in electronic box	°C
833	Temperature In electronic box Max	Maximum temperature that occurred in electronic box	°C
834	Temperature In electronic box Avg	Average temperature that occurred in electronic box	°C
847	Pilot Position Min.	Minimum pilot position that occurred	%
848	Pilot Position Max	Maximum pilot position that occurred	%
849	Pilot Position Avg	Average pilot position during operation	%
853	Command Min	Minimum command that occurred	%
854	Command Max	Maximum command that occurred	%
855	Command Avg	Average command during operation	%
1056	Error Word	Last occurred error	
1064	Error Memory 1 Error	Error memory 1 - error type	
1065	Error Memory 1 Day	Error memory 1 - day in which the error occurred	day
1066	Error Memory 1 Hour	Error memory 1 - hour in which the error occurred	hour
1067	Error Memory 1 Minute	Error memory 1 - minute in which the error occurred	minutes
1068	Error Memory 2 Error	Error memory 2 - error type	-
1069	Error Memory 2 Day	Error memory 2 - day in which the error occurred	day
1070	Error Memory 2 Hour	Error memory 2 - hour in which the error occurred	hour
1071	Error Memory 2 Minute	Error memory 2 - minute in which the error occurred	minutes
1072	Error Memory 3 Error	Error memory 3 - error type	
1073	Error Memory 3 Day	Error memory 3 - day in which the error occurred	day
1074	Error Memory 3 Hour	Error memory 3 - hour in which the error occurred	hour
1075	Error Memory 3 Minute	Error memory 3 - minute in which the error occurred	minutes
1076	Error Memory 4 Error	Error memory 4 - error type	
1077	Error Memory 4 Day	Error memory 4 - day in which the error occurred	day
1078	Error Memory 4 Hour	Error memory 4 - hour in which the error occurred	hour
1079	Error Memory 4 Minute	Error memory 4 - minute in which the error occurred	minutes
1080	Error Memory 5 Error	Error memory 5 - error type	
1081	Error Memory 5 Day	Error memory 5 - day in which the error occurred	day
1082	Error Memory 5 Hour	Error memory 5 - hour in which the error occurred	hour

## Valve Parameter - read only

Parameter	Function	Description	Unit
1083	Error Memory 5 Minute	Error memory 5 - minute in which the error occurred	minutes
1084	Error Memory 6 Error	Error memory 6 - error type	
1085	Error Memory 6 Day	Error memory 6 - day in which the error occurred	day
1086	Error Memory 6 Hour	Error memory 6 - hour in which the error occurred	hour
1087	Error Memory 6 Minute	Error memory 6 - minute in which the error occurred	minutes
1088	Error Memory 7 Error	Error memory 7 - error type	
1089	Error Memory 7 Day	Error memory 7 - day in which the error occurred	day
1090	Error Memory 7 Hour	Error memory 7 - hour in which the error occurred	hour
1091	Error Memory 7 Minute	Error memory 7 - minute in which the error occurred	minutes
1092	Error Memory 8 Error	Error memory 8 - error type	
1093	Error Memory 8 Day	Error memory 8 - day in which the error occurred	day
1094	Error Memory 8 Hour	Error memory 8 - hour in which the error occurred	hour
1095	Error Memory 8 Minute	Error memory 8 - minute in which the error occurred	minutes
1096	Error Memory 9 Error	Error memory 9 - error type	
1097	Error Memory 9 Day	Error memory 9 - day in which the error occurred	day
1098	Error Memory 9 Hour	Error memory 9 - hour in which the error occurred	hour
1099	Error Memory 9 Minute	Error memory 9 - minute in which the error occurred	minutes
1100	Error Memory 10 Error	Error memory 10 - error type	
1101	Error Memory 10 Day	Error memory 10 - day in which the error occurred	day
1102	Error Memory 10 Hour	Error memory 10 - hour in which the error occurred	hour
1103	Error Memory 10 Minute	Error memory 10 - minute in which the error occurred	minutes
1186	Command Signal Analog	Analog command signal	%
1187	Command Signal Digital	Digital command signal (IO-Link)	%
1189	Internal Command Signal	Internal command signal from the valve controller to the valve actuator	%
1194	Actual Pilot Position	Actual position of the pilot stage	%

## Error Codes

Error code	Error Description
0	no errors
8	overvoltage error
13	electronics temperature too low (< -20 °C)
14	electronics temperature too high (> 85 °C)
15	electronics temperature exceeded
16	over current shutdown
26	cable break command signal
27	cable break feedback signal 1
28	cable break feedback signal 2
51	firmware restarted
52	hardware failure
67	"spool Fail-Safe monitoring the valve spool has left the power-down-range"
71	hardware failure
72	hardware failure
73	hardware failure
74	hardware failure
82	undervoltage error
83	over current shutdown
84	over current shutdown
85	over current shutdown
86	over current shutdown
91	actuator shut down - overtemperature shutdown

## Operation Manual

### LED flashing signals of the valve electronics

The device status is indicated by an LED with two color fields. Different device states are indicated by the color combinations and the flashing frequency.



Device status	LED field 1		LED field 2	
	Colour	Flash frequency	Colour	Flash frequency
<b>Normal</b>				
Active	Green	Permanent	Green	Permanent
Disabled	Green	1 Hz	Green	1 Hz
On Hold	Green	0.5 Hz	Green	0.5 Hz
<b>Warning</b>				
Active	Yellow	Permanent	Yellow	Permanent
Disabled	Yellow	1 Hz	Yellow	1 Hz
<b>Error</b>				
Active	Red	Permanent	Red	Permanent
Disabled	Red	1 Hz	Red	1 Hz
<b>Normal + active IO Link communication</b>				
Active	Blue	Permanent	Green	Permanent
Disabled	Blue	1 Hz	Green	1 Hz
On Hold	Blue	0.5 Hz	Green	0.5 Hz
<b>Warning + active IO Link communication</b>				
Active	Blue	Permanent	Yellow	Permanent
Disabled	Blue	1 Hz	Yellow	1 Hz

### Air Bleeding of Hydraulic System

During initial startup, after an oil change as well as after the opening of lines or valves the hydraulic system must be air bled.

### Filter

The function and lifetime of the valve are strongly affected by the cleanliness of the fluid.

Purity level class of 18/16/13 acc. ISO4406 is required.

### Flushing

It is recommended to flush the pipelines by short circuiting the pressure and return lines. This prevents the installation dirt from entering the valve.

## 7. Shut-off Valve TEP\*B

**Product Name D3DW**

### CE Mark

The CE mark appears on the main nameplate. If the product is installed as part of a larger machine, this larger machine is in turn subject to EU directives and must therefore obtain a general CE mark for the machine as a whole. The machine must not enter circulation in the EU until this is done.

### Conformity

The declaration of conformity (see page 17) attests that the products comply with all essential health and safety requirements set out in Annex I of the Machinery Directive 2006/42/EC.

☞ If our product is used in ways other than specified, hazards may occur that could not be foreseen by the manufacturer. Any resulting loss or damage is not the responsibility of Parker Hannifin.

☞ If the described product is installed in a machine that came into circulation before 1995, note the following:  
If the function has not been changed significantly, commissioning may not take place until conformity with national occupational health and safety provisions has been established for the machine as a whole, in particular those provisions implementing the Use of Work Equipment Directive.  
If the function has been changed significantly, a new conformity procedure must be carried out in accordance with the Machinery Directive 2006/42/EC.

### Electronic Control System

The D3DW valve must be operated by the user with a suitable control system.

The valve is connected using separate wires for solenoids/position control.

### Solenoid Connection Shut-off valve TFP\*B

Each solenoid connection requires one plug 2 + PE as specified in EN 175301-803.

### Connection of Plug

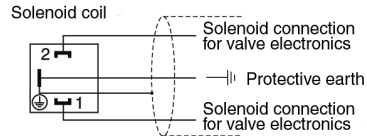

☞ The plug for the solenoid must be ordered separately.

### Deliverable version

Thread	Colour	Mark	Order no.
PG9	grey	A	5001711
PG11	grey	A	5001717

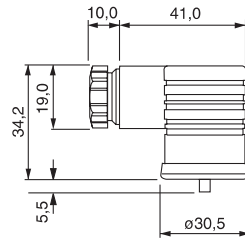

The wiring must meet the following specifications:

Type	Flexible control cable, 3-core
Size	Min. 1.5 mm <sup>2</sup>
External diameter	PG9: 4.5...7 mm PG11: 6...9 mm
Length	Max. 50 m

☞ For lengths >50 m please contact Parker.  
The sealing surface of the valve must be properly connected to the earthed frame of the machine. Connect the earth wire and cable shield to the protective earth in the electrical cabinet.

Use the screw connectors to attach the wires to the plug. Use a suitable tool to tighten the screw at the cable entry point.

 Failure to tighten the screw connectors may cause the connectors to loosen and may impair the seal.

If you are using plugs from other manufacturers, follow the relevant instructions.

 Short circuits between the wires, poor workmanship or incorrect attachment of the shielding may cause disruption and the failure of the valve and the electronic control system.

## Sensor Connection

See "Technical data" page 18

## Choice of Solenoid

The choice of a suitable solenoid is an important factor in the operational reliability of the valve. The D3DW is available with various solenoid voltages. If the solenoid can be adjusted by setting parameters in the electronic control system, the suitable solenoid options must be selected.

 Note about using valves with actuating solenoids:

The current drops as the solenoid heats up. The lower current has no effect on valve operation, provided the specified voltage is maintained at the valve.

 A suitable tool must if necessary be used for manual emergency actuation of the solenoid.

## Remaining Risk

### Allergic Reactions

Hydraulic oil can cause allergic reactions on susceptible skin. This can be prevented by taking the precautions that are usual when handling mineral oil products and by using personal protective equipment.

### Leaking Plugs

 Leaking plugs can cause a malfunction. That is why the plugs must be checked for leaks at the regular maintenance interval. Leaking plugs may constitute a safety hazard, so the valve must be returned to the manufacturer for repair.

## Lightning

 If electronic components are exposed to electromagnetic fields as a result of lightning, they must be checked to ensure they are still working perfectly. If there is a malfunction, the product must be returned to the manufacturer.

## Temperature

The surface of our product may heat up in use.

 The service temperatures may exceed the temperature threshold for burn injury, 70 °C. Above this threshold, even brief contact with the surface may result in a burn.

The only way to consistently prevent burn injuries is to use personal protective equipment and to remain safety-conscious at all times.

 If integrated electronics are exposed to a temperature above 80 °C, they may malfunction.

## Power Failure

 In a power failure the valve piston returns to the spring centred starting position.

You must check whether this creates potential hazards when the system/machine is used.

## Hydraulic

The D3DW is tested and approved with an even flow. If the flow becomes asymmetrical, the safety function of the valve may be compromised. You should therefore carry out tests before commissioning to verify that the valve is in good working order. If the valve piston has been under pressure and stationary in the end position for an extended period, oil particles may cause the piston to seize. For this reason the valve should be actuated regularly.

## Electrical Connection for Position Control TFP\*B

The position control can be connected as normally closed or normally open. In principle, we recommend a normally closed connection, as this is the only way to ensure that position control works properly

### Operation Manual

#### Correct Use

Our products are manufactured using state of the art technology and recognised safety procedures.

The D3DW is designed for mould closing devices in injection moulding machines according to the manufacturer's installation instructions (see page 19).

According to section 1(2b) of accident prevention guidelines "Injection moulding machines" (VGB 7 ac) and section 5 of EN 201:1997 "Injection moulding machines. Safety requirements", the valves must be independently monitored by the control system of the injection moulding machine, such that if position control fails, a new machine cycle is prevented from starting.

#### Function

The D3DW is devised that influence the direction of a flow. To do this, connections between the various ports are made or broken. Activating the solenoid or the hydraulic pilot causes the piston in the valve to move to the end position.

If the electrical signal is removed, the installed spring pushes the piston back to its starting position.

The purpose of the installed position control is to detect when the piston is in the starting position.

 The shut-off function causes a control error when the proportional valve is active, which cannot be corrected due to the hydraulic separation.

#### Electrical Connections

Before commissioning,

- all electrical connections must be made professionally, using suitable ducting,
- parts of the machine and individually installed components must be adequately earthed,
- all limit switches and control elements must be properly integrated with the control system.

#### Hydraulic Requirements for Pilot Operated Directional Control Valves

To guarantee that the main piston operates reliably at all times, the minimum pilot pressure must be provided. To achieve this, a suitable combination of flow and return arrangements must be selected for the pilot oil.

#### Other Documentation

##### Other Applicable Standards / Rules

- 2006/42/EC  
Machinery Directive
- 2014/35/EC  
Low Voltage Directive
- ISO 4406  
Hydraulic fluid power - Fluids - Method for coding the level of contamination by solid particles
- ISO 4401:2005-07  
Hydraulic fluid power - four-port directional control valves - mounting surfaces
- DIN EN 201: 2010-02 / section 5  
Rubber and plastics machines - Injection moulding machines - Safety requirements
- DIN EN 14123-1: 2016-03  
Safety of machinery - Reduction of risks to health from hazardous substances emitted by machinery -  
Part 1: Principles and specifications for machinery manufacturers
- DIN EN 60204-1/A1: 2009-10;  
VDE0113-1:2009-10  
Safety of machinery – Electrical equipment of machines – Part 1: General requirements
- DIN EN 60529: 2014-09;  
VDE0470-1:2014-09  
Degrees of protection provided by enclosures (IP code)
- 2014/30/EC  
Electromagnetic compatibility
- DIN 51524-1:2006-04  
Pressure fluids - hydraulic oils - part 1: hydraulic oils HL; minimum requirements
- DIN 51525-2:2006-04  
Pressure fluids - hydraulic oils - part 1: hydraulic oils HLP; minimum requirements
- German Occupation Safety Ordinance (Betriebssicherheitsverordnung)
- German Labour Protection Act (Arbeitsschutzgesetz)

Technical Data Position Control Switch TFP\*B

Supply voltage	[VDC]	24
Tolerance supply voltage	[%]	±20
Ripple supply voltage	[%]	≤10
Polarity protection	[V]	300
Current consumption without load	[mA]	≤20
Switching hysteresis	[mm]	<0.06
Max. output current per channel, ohmic	[mA]	250
Ambient temperature	[°C]	-20 ... +85
Protection		IP65 acc. EN 60529
CE conform		EN 61000-4-2/EN 61000-4-4/EN 61000-4-6 <sup>1)</sup> /ENV 50140/ENV 50204
Min. distance to next AC solenoid	[m]	0.1
Interface		M12x1 to IEC 61076-2-101



The factory setting of the position control switch must not be changed.

Notes on Installation

- Connections to the limit switch must be laid separately from mains connections, for example power supplies to motors or magnets, because inductive voltage peaks would otherwise pass via the supply network to the limit switch, which could be damaged even though a protection circuit is installed.
- A suitable DC power supply is required for the switch. The ripple of the power supply must not exceed 10 %.
- Voltage spikes occurring when inductive loads are removed should be eliminated using a suitable protection circuit, for example flyback diodes.
- A built-in overload protection circuit suspends the switching function of the limit switch if an overload occurs. When the overload ends, the limit switch automatically resumes operation.
- The limit switch must not be installed close to AC consumers, e.g. AC solenoids, which may cause disruption. A minimum distance of 0.1 m must be observed in all cases.
- The product may only be operated in the conditions set out in the technical data.
- Connections must follow the connection list.

Connection Diagram

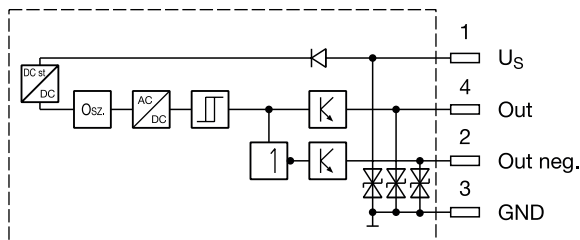

Outputs: Open collector

<sup>1)</sup> Only guaranteed with screened cable and female connector

Limit Switch Type 118368-01

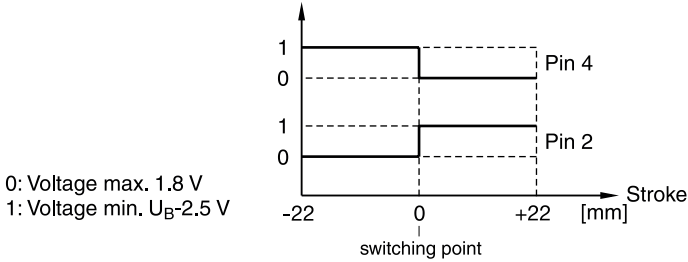

This switch is dedicated for the supervising of **one** trip point. When the trip point is reached, pin 4 is non conducting, this means a **normally closed** function. Simultaneously pin 2 becomes conducting, this means a **normally open** function.

Wirings

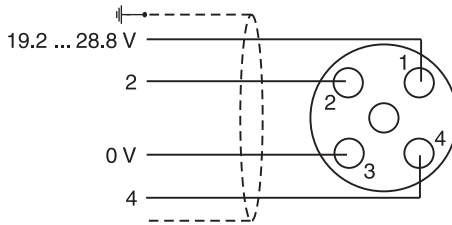

Installation

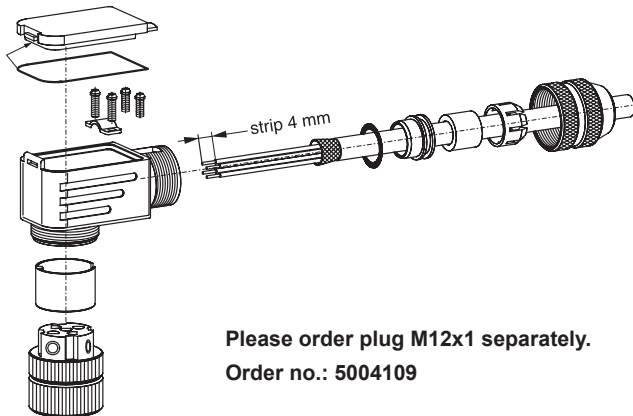

Please order plug M12x1 separately.  
Order no.: 5004109

## Operation Manual

### Air Bleeding of Hydraulic System

During initial startup, after an oil change as well as after the opening of lines or valves the hydraulic system must be air bled.

### Filter

The function and lifetime of the valve are strongly affected by the cleanliness of the fluid.

Purity level class of 18/16/13 acc. DIN ISO 4406 is required.

### Flushing

It is recommended to flush the pipelines by short circuiting the pressure and return lines. This prevents the installation dirt from entering the valve.

### 6. Troubleshooting

Basis of troubleshooting is always a systematic approach.



For suspect of a sluggish spool the valve may be flushed with clean pressure fluid.



Troubleshooting in a hydraulic system requires detailed knowledge about function and construction of the system. Therefore the work may exclusively be performed by qualified personnel.

malfunction at hydraulic load runtime							
						- generally no function	
						- high frequent oscillation	
						- low frequent oscillation	
						- speed variations at unchanging command	
						- different speeds depending on travel direction	
						- speed too low	
						- drifting without command	
				possible reasons for malfunction	corrective actions		
X						hydraulic pump resp. motor defective	replace hydraulic pump resp. motor
X	X	X	X	X		drive overloaded	reduce pressure resp. speed, increase valve size
X	X	X	X	X	X	valve contaminated	clean pressure fluid, filter / flush valve
		X	X			hydraulic fluid too viscous / too cold	change fluid grade, provide operational temperature
X	X					too low oil level within tank	refill pressure fluid
		X	X	X		filter contaminated	clean resp. replace filter
X	X			X	X	supply voltage too low	keep supply voltage range
	X					supply voltage carries too much ripple	reduce ripple
X				X		command signal too low	increase command signal
	X					command signal carries too much ripple	reduce ripple
			X			center position adjustment incorrect	check center position adjustment
X	X	X	X	X	X	contacts of central connector contaminated	clean contacts / replace plug
X						feed cable interrupted	fix feed cable
X	X	X	X	X	X	wiring sequence incorrect	correct wiring sequence
	X				X	feed cable without shielding	change cable grade

## 9. Accessories

The following accessories are available for the valve series TFP:

Female connector 6+PE ordering code 5004072

Mounting bolts see table on page 9.

Please direct technical product enquiries to:

**Parker Hannifin**

**Manufacturing Germany GmbH & Co. KG**

Industrial Systems Division Europe

Gutenbergstr. 38

41564 Kaarst, Germany

E-mail: [isde.kaarst.support@support.parker.com](mailto:isde.kaarst.support@support.parker.com)

## Spare Parts / Seal Kits

Size	NBR	FPM
TFP025	SK-TFW025AN	SK-TFW025AV
TFP032	SK-TFP032AN	SK-TFP032AV
TFP040	SK-TFP040AN	SK-TFP040AV
TFP050	SK-TFP050AN	SK-TFP050AV
TFP063	SK-TFP063AN	SK-TFP063AV
TFP080	SK-TFP080AN	SK-TFP080AV
TFP100	SK-TFP100AN	SK-TFP100AV

**Hotline in Europe**  
**Tel.: 00800-2727-5374**

