

**Characteristics**

2-way servo proportional valves with VCD® technology and shut-off valve series TEP base on the TDP range. Additionally, TEP valves are equipped with a direction control valve for shutting off the pilot system.

**Structure and function**

The 2-way servo proportional valves with shut-off valve TEP have a 2-stage design consisting of a DFplus pilot valve and a main stage with poppet and LVDT.

With the DFplus pilot valve the TEP achieves extremely fast response times: from 10.5 ms (NG25) up to 28 ms (NG100) with an accuracy of <0.1 % of the nominal flow. The pilot valve actively controls the poppet - independent of the pressure conditions in the main ports. It is basically required that the pilot pressure is at the level of the system pressure. At low system pressure the pilot pressure should be min. 140 bar, when high valve dynamics are desired.

The integrated electronics in the pilot of the TEP has two control loops for the main poppet and the pilot spool.

In the de-energized position of the shut-off valve, the upper pilot control surface of the main spool is pressurized, the lower one is relieved to tank. Independent of the DFplus pilot valve, the main spool remains always closed, if the shut-off valve is not activated.

If the solenoid of the shut-off valve is energized, the position of the main spool is controlled by DFplus pilot valve and LVDT.



TEP040

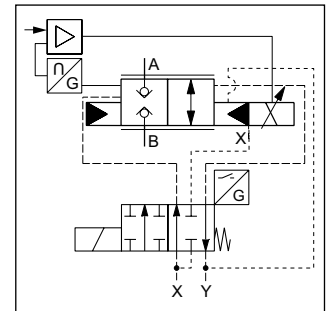

**Features**

- Active pilot operated 2-way servo proportional valves with shut-off valve
- Flow directions A-B and B-A
- Cavity and mounting pattern according to ISO 7368
- Fast step responses
- Completely mounted and adapted unit with integrated electronics
- In order to ensure the closed position pilot pressure is required
- 7 sizes, NG25 up to NG100
- Shut-off function

**TEP040**

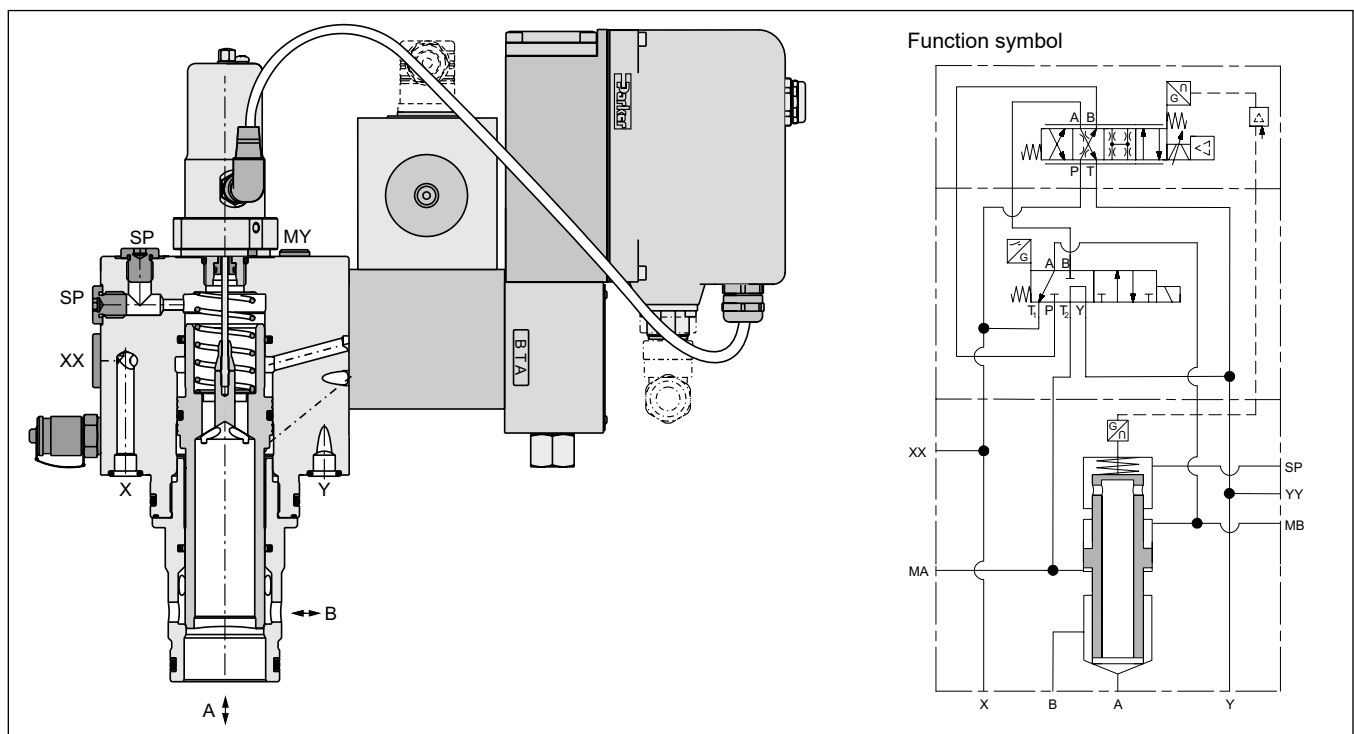

TEP UK.indd 16.08.23

Ordering Code / Performance Curves

Ordering code

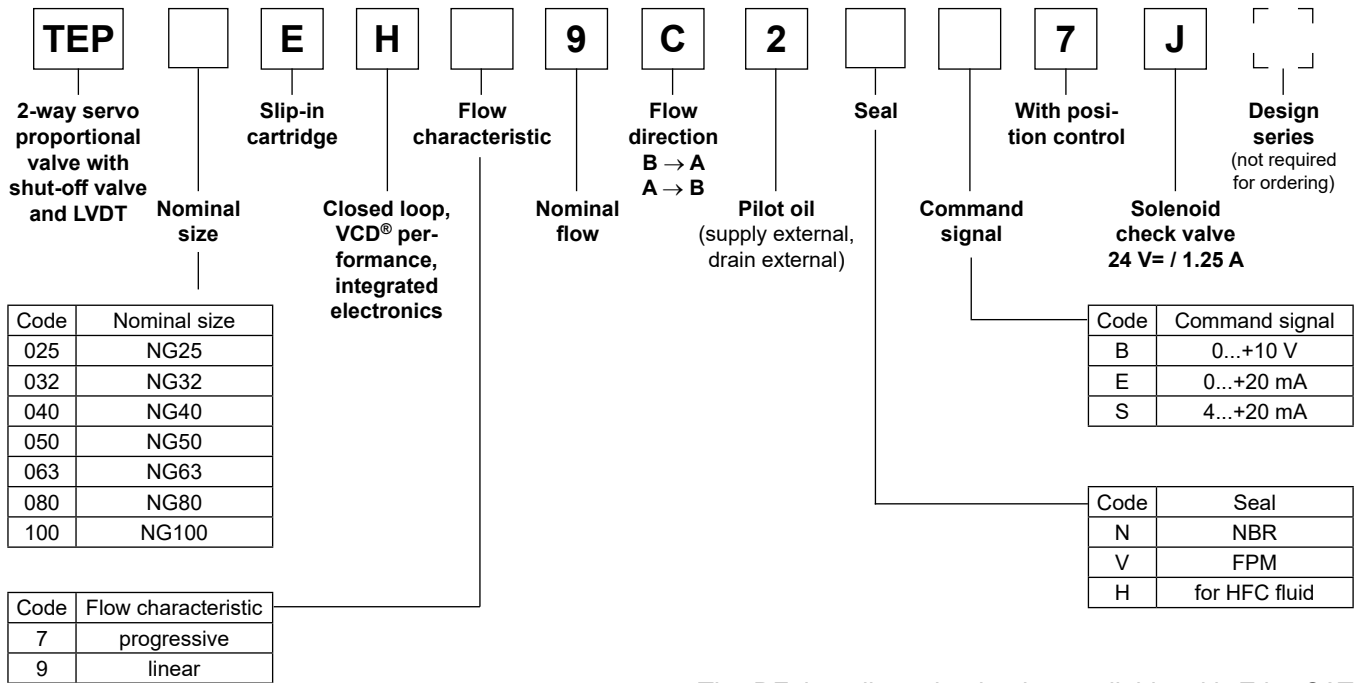

The DFplus pilot valve is also available with EtherCAT interface, see chapter 3, D\*FP and D\*1FP with EtherCAT.

Please order connector separately.

Angle female connector must be used for NG25 to NG50.

Characteristic flow/signal line

Δp = 5 bar

Linear (code 9)

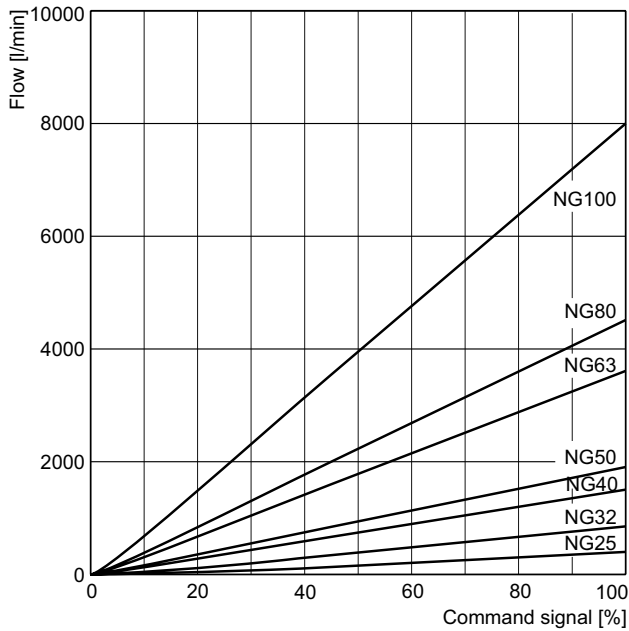

Progressive (code 7)

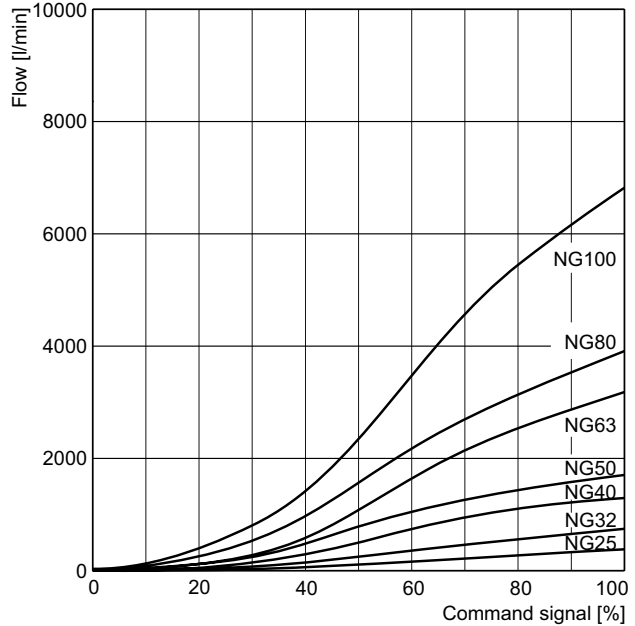

Opening point factory set to 3 %

Characteristic curve measured with HLP46 at 50 °C.

$$\text{Flow at different } \Delta p \quad Q_{\text{actual}} = Q_{\text{nominal}} \cdot \sqrt{\Delta p_{\text{actual}} / \Delta p_{\text{nominal}}}$$

1) Please order female connector M12x1 separately (see accessories, directional control valves, female connector M12x1 (order no.: 5004109).

General								
Design	Proportional throttle valve with LVDT and integrated electronics, slip-in cartridge according to ISO 7368							
Nominal size	DIN	<b>NG25</b>	<b>NG32</b>	<b>NG40</b>	<b>NG50</b>	<b>NG63</b>	<b>NG80</b>	<b>NG100</b>
Mounting position	unrestricted							
Ambient temperature	[°C]	-20...+50						
Weight	[kg]	11	13	15	26	52	105	157
Vibration resistance	[g]	10 sinus 5...2000 Hz acc. IEC 68-2-6 10 (RMS) random noise 20...2000 Hz acc. IEC 68-2-36 15 shock acc. IEC 68-2-27						
Hydraulic								
Max. operating pressure	[bar]	Ports A, B, X and SP up to 350; XX observe accumulator pressure rating; port Y: max. 35						
Fluid	Hydraulic oil according to DIN 51524							
Fluid temperature	[°C]	-20...+60 (NBR: -25...+60)						
Viscosity	recommended	[cSt] / [mm <sup>2</sup> /s]	30 ... 80					
	permitted	[cSt] / [mm <sup>2</sup> /s]	20 ... 400					
Filtration	ISO 4406; 18/16/13							
Nominal flow at Δp= 5 bar (linear)	[l/min]	420	850	1500	1900	3600	4500	8000
Recommended max. flow (linear)	[l/min]	800	2000	3000	4500	8000	13000	20000
Nominal flow at Δp= 5 bar (progressive)	[l/min]	380	750	1300	1700	3200	3900	6800
Recommended max. flow (progressive)	[l/min]	700	1750	2600	4000	7000	11250	17000
Flow direction	B to A / A to B							
Pilot pressure	[bar]	must be as high as system pressure						
Pilot oil supply	external via X							
Pilot oil drain	external via Y							
Leakage in pilot valve at 100 bar	[ml/min]	< 400						
Pilot valve size	NG06			NG10				
Max. pilot flow at 140 bar pilot pr.	[l/min]	23	30	40	40	70	80	100
Static/dynamic								
(for optimal dynamics see installation recommendation)								
Step response at pilot press. >140 bar	[ms]	10.5	12	14	20	17	23	28
Frequency response at pilot press. >140 bar								
Amplitude -3 dB; 10 % ±5 %	[Hz]	95	80	74	66	52	46	41
Phase -90°; 10 % ±5 %	[Hz]	85	63	59	52	56	51	47
Hysteresis	[%]	< 0.1						
Sensitivity	[%]	< 0.05						
Temperature drift	[%/K]	< 0.025						

Electrical							
Duty ratio	[%]	100					
Protection class	IP65 in accordance with EN 60529 (with correctly mounted plug-in connector)						
Supply voltage / ripple	[V]	DC 22 ... 30, electric shut-off at < 19, ripple < 5 % eff., surge free					
Current consumption max.	[A]	3.5					
Pre-fusing	[A]	4.0 A medium lag					
Input signal	Code B	Voltage	[V]	0...+10, ripple < 0.01 % eff., surge free			
		Impedance	[kOhm]	100			
	Code E	Current	[mA]	0...+20, ripple < 0.01 % eff., surge free			
		Impedance	[Ohm]	< 250			
	Code S	Current	[mA]	4...20, ripple < 0.01 % eff., surge free			
				< 3.6 mA = disable, > 3.8 mA = enable on according to NAMUR NE43			
		Impedance	[Ohm]	< 250			
Differential input max.	[V]	30 for terminal D and E against PE (terminal G) 11 for terminal D and E against 0V (terminal B)					
Enable signal	[V]	5...30, Ri = > 8 kOhm					
Diagnostic signal	[V]	0...+10 / +12.5 error detection, rated max. 5 mA					
EMC	EN 61000-6-2, EN 61000-6-4						
Electrical connection	6 + PE acc. EN 175201-804						
Wiring min.	[mm <sup>2</sup> ]	7 x 1.0 (AWG16) overall braid shield					
Wiring length max.	[m]	50					

<sup>1)</sup> If valves with onboard electronics are used in safety-related parts of control systems, in case the safety function is requested, the valve electronics voltage supply is to be switched off by a suitable switching element with sufficient reliability.

**Installation Recommendations / Electronics**

**Installation recommendations**

An insufficient pilot oil supply (e.g. due to long distances and/or small diameters) can negatively influence the dynamics of the TEP valve.

To avoid this, an accumulator can be connected to port XX at the valve body of the TEP. A short-term undersupply with pilot oil can be compensated via this accumulator.

Sizing data: see operation manual.

Please also consider the Parker accumulator product range and the Parker Accumulator Sizing Software.

**Block circuit diagram electronics**

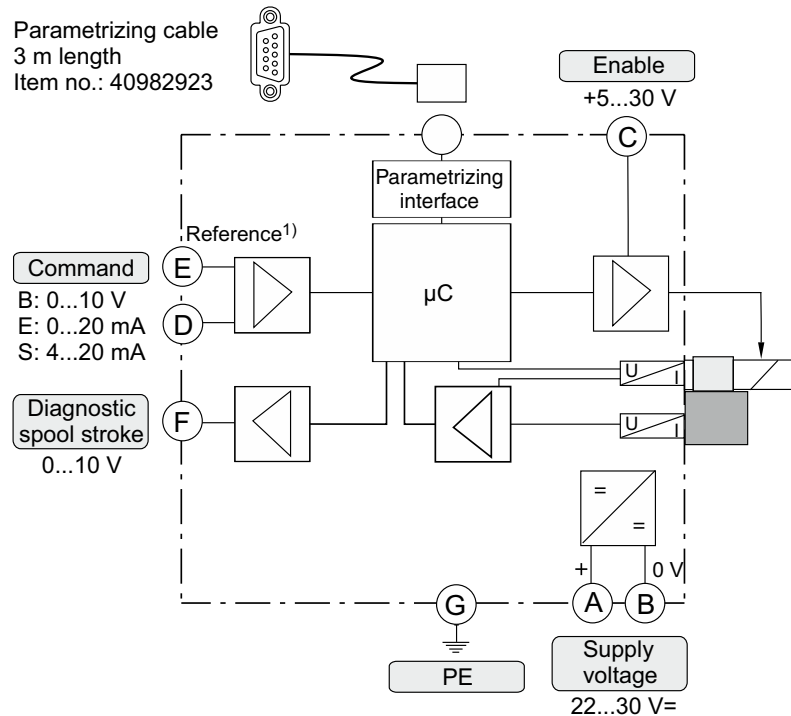

**Connection diagrams electronics**

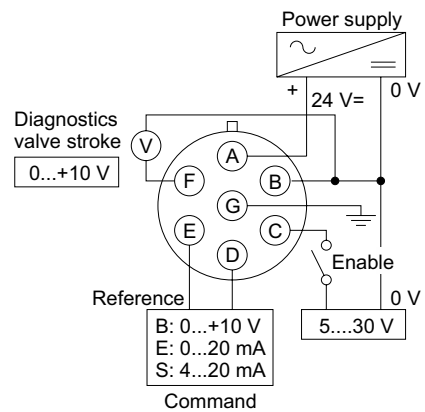

8

**Female connector for NG63 to NG100**  
(EMC conform)

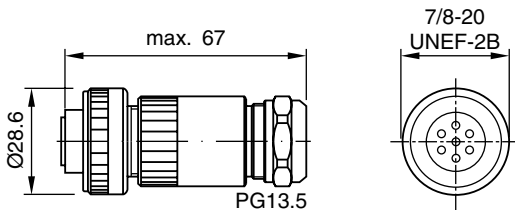

ID no. 5004072

Please order plugs separately.

**Angle female connector for NG25 to NG50**  
(EMC conform)

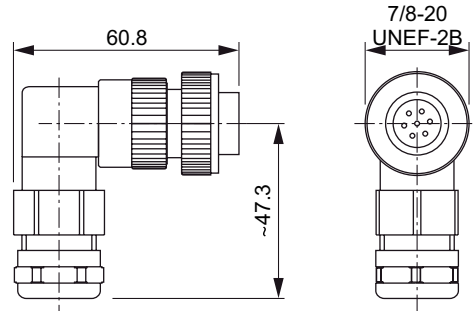

ID no. 5005160

<sup>1)</sup> Do not connect with the supply voltage zero.

**Single solenoid valve**

**Electrical characteristics of position control as per IEC 61076-2-101 (M12x1)**

Supply voltage	[VDC]	24
Tolerance supply voltage	[%]	±20
Ripple supply voltage	[%]	≤10
Polarity protection	[V]	300
Current consumption without load	[mA]	≤20
Switching hysteresis	[mm]	<0.06
Max. output current per channel, ohmic	[mA]	250
Ambient temperature	[°C]	-20 ... +60
Protection		IP65 acc. EN 60529 (with correctly mounted plug-in connector)
Min. distance to next AC solenoid	[m]	0.1
Interface		M12x1 to IEC 61076-2-101
CE conform		EN 61000-4-2 / EN 61000-4-4 / EN 61000-4-6 <sup>1)</sup> / ENV 50140 / ENV 50204

<sup>1)</sup> Only guaranteed with screened cable and female connector

**M12 pin assignment**

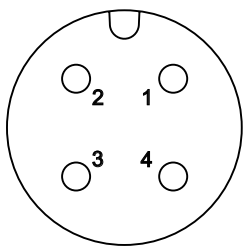

- 1 + U<sub>S</sub> 19.2...28.8 V
- 2 Out B: normally open
- 3 0V
- 4 Out A: normally closed

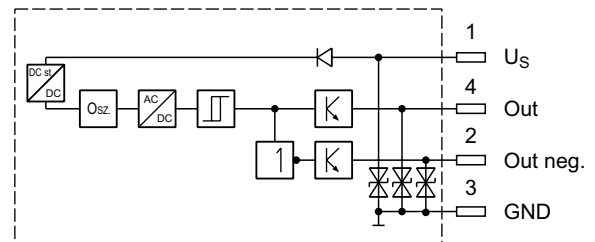

Outputs: Open collector

Please order female connector M12x1 separately (see accessories, directional control valves, female connector M12x1 (order no.: 5004109).

Dimensions

NG25

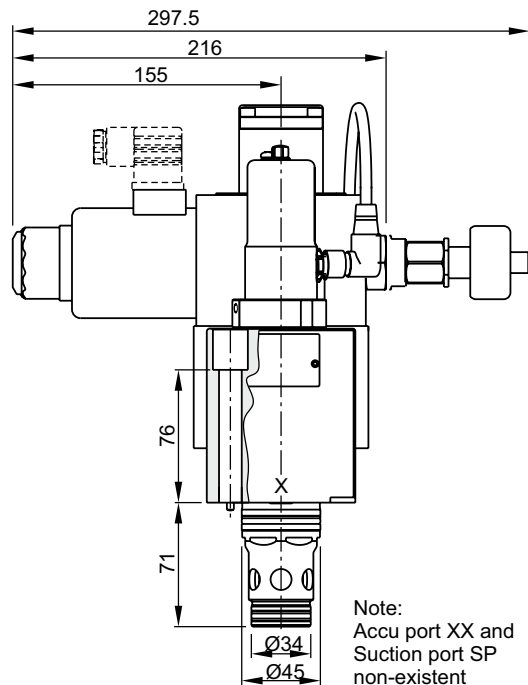
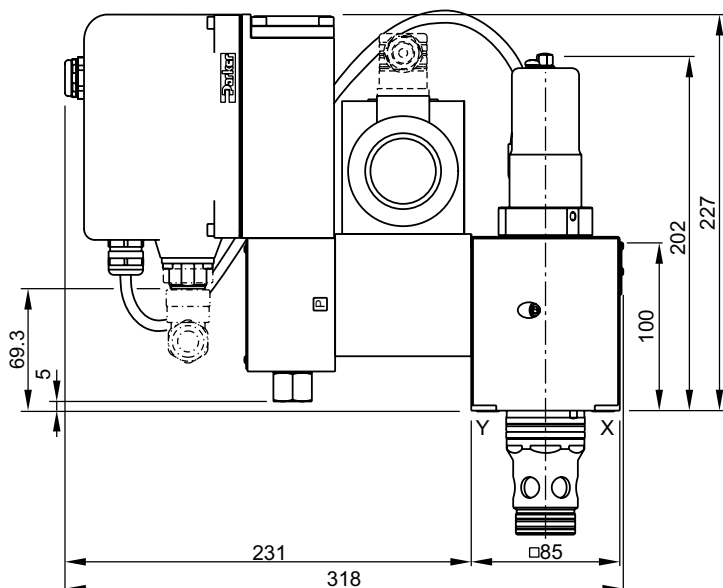

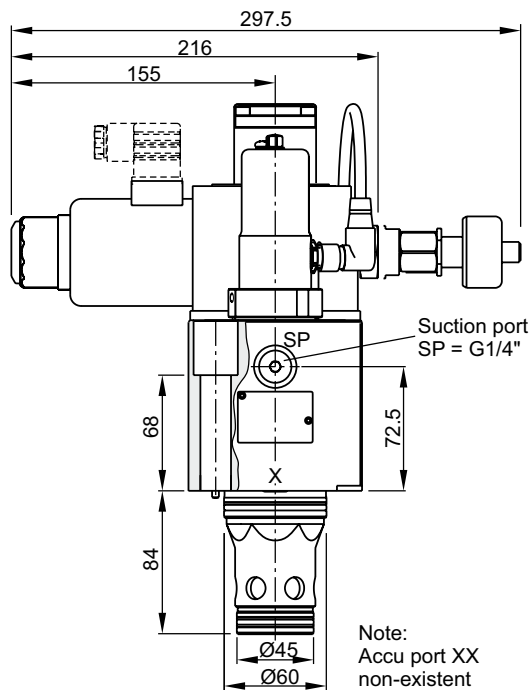
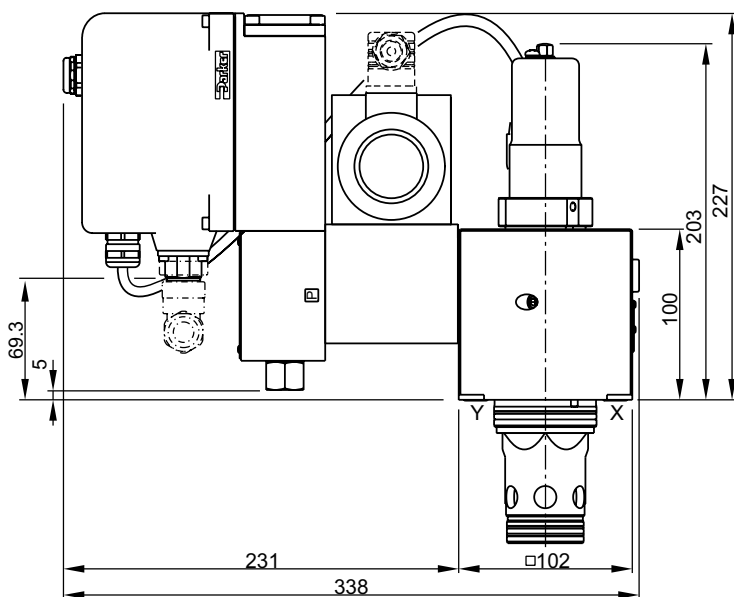

NG32

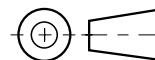

8

Suction port SP: Contact Parker for installation recommendation.

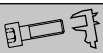

NG	Bolt kit - 		NBR	Kit	FPM
25	BK504 4 x M12x100 ISO 4762-12.9	108 Nm	SK-TEP025EN		SK-TEP025EV
32	BK529 4 x M16x100 ISO 4762-12.9	264 Nm	SK-TEP032EN		SK-TEP032EV

1) Please order female connector M12x1 separately (see accessories, directional control valves, female connector M12x1 (order no.: 5004109).

**NG40**

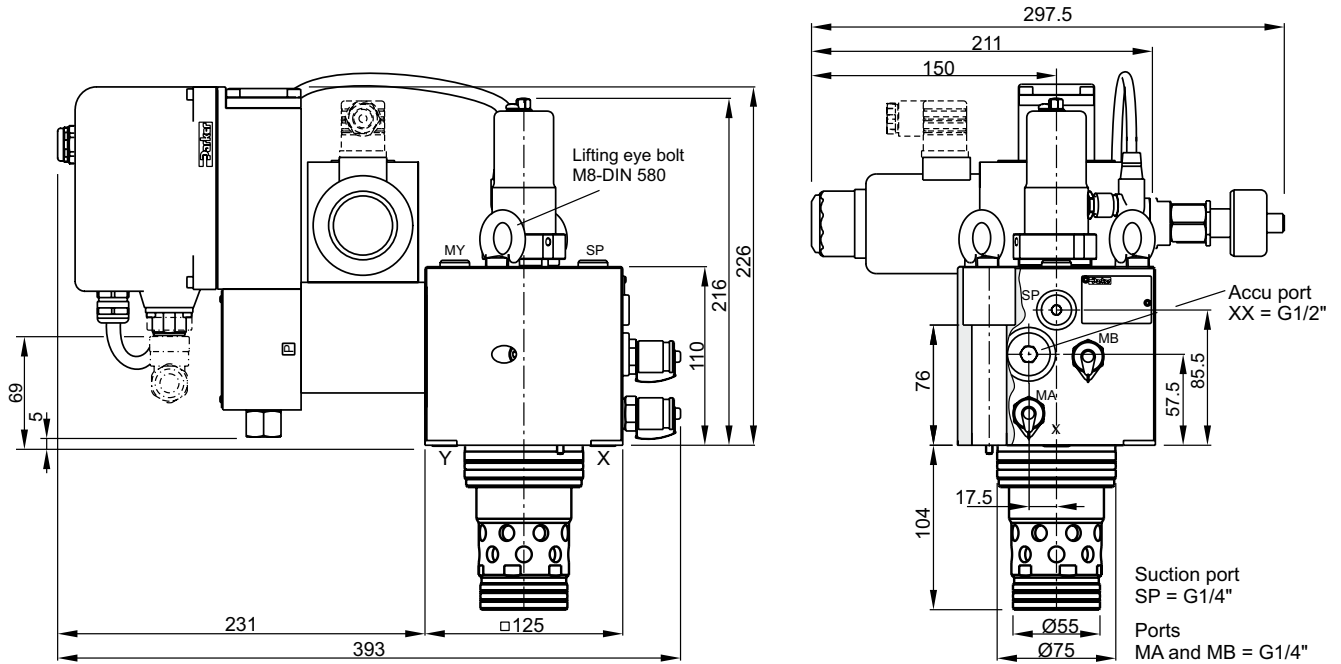



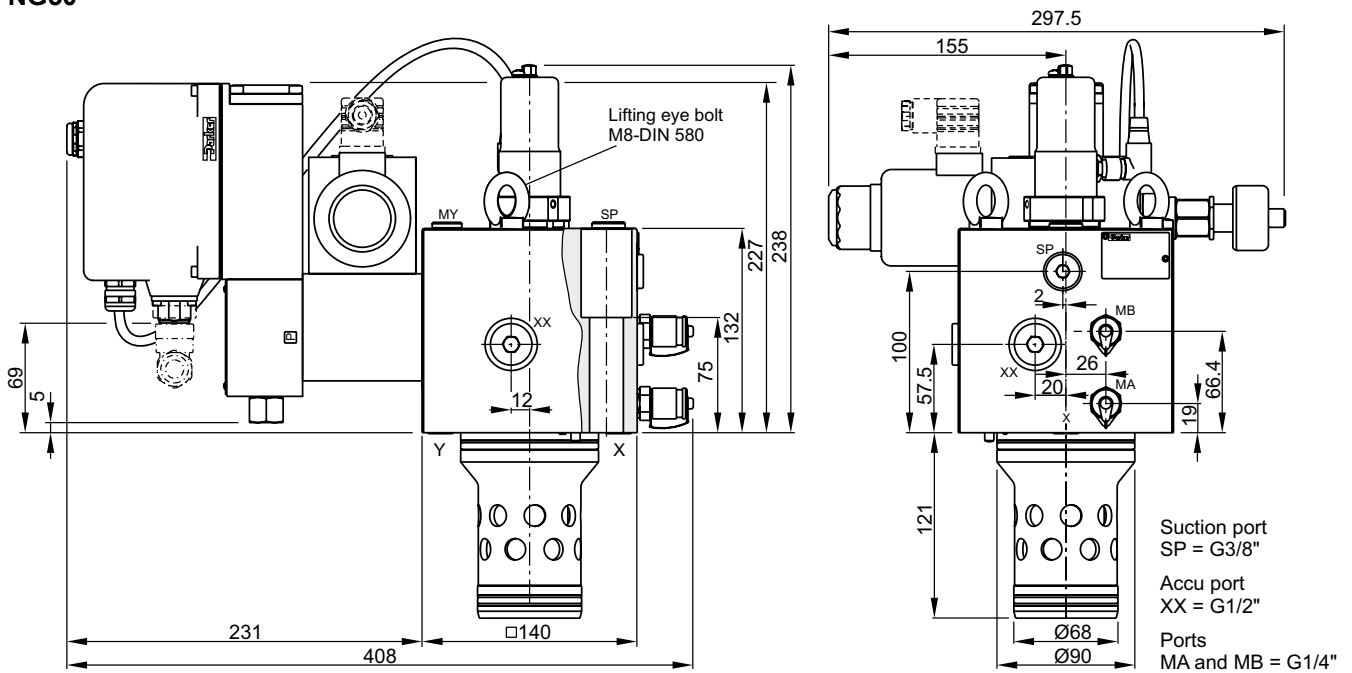

**NG50**

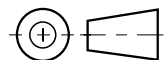

Lifting thread for disassembly M12

**Suction port SP:** Contact Parker for installation recommendation.



NG	Bolt kit - 		NBR	Kit 	FPM
40	BK481 4 x M20x110 ISO 4762-12.9	517 Nm	SK-TEP040EN		SK-TEP040EV
50	BK481 4 x M20x110 ISO 4762-12.9	517 Nm	SK-TEP050EN		SK-TEP050EV

<sup>1)</sup> Please order female connector M12x1 separately (see accessories, directional control valves, female connector M12x1 (order no.: 5004109).

**Dimensions**

**NG63**

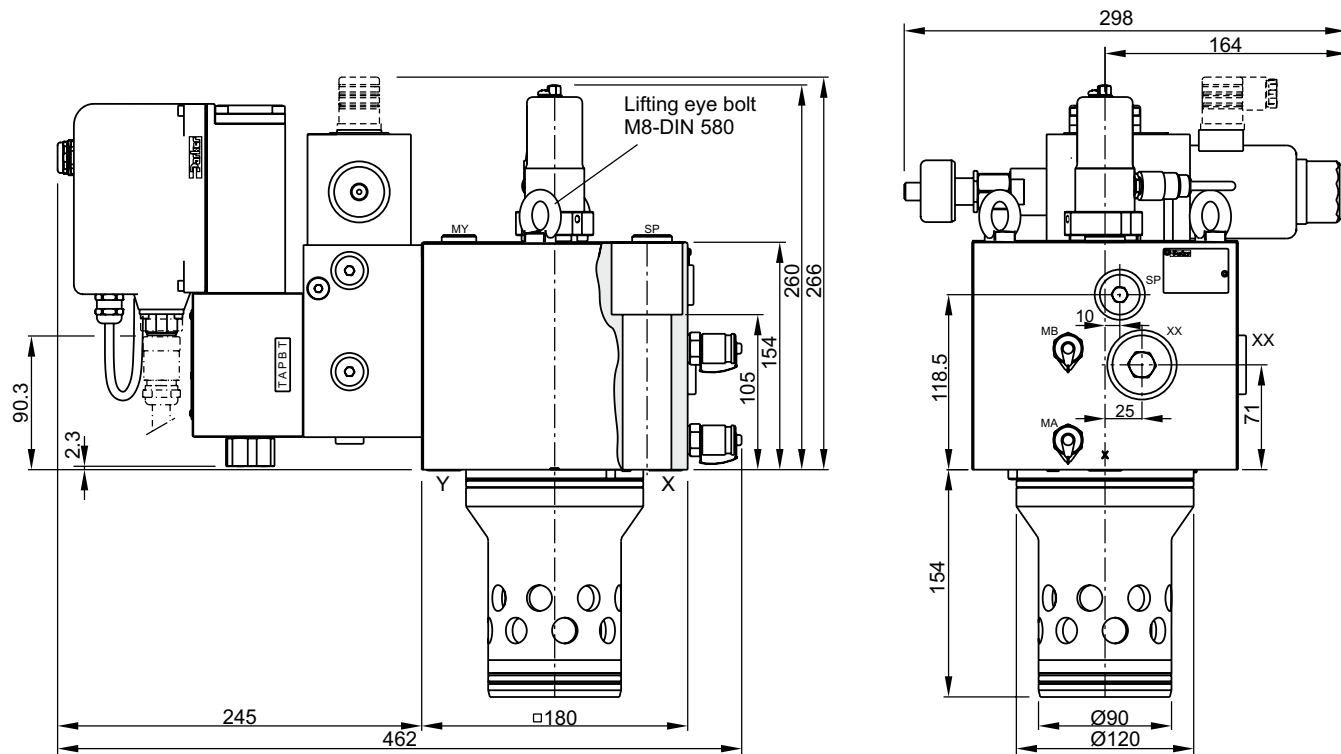



Suction port    Accu port    Ports  
 SP = G1/2"    XX = G3/4"    MA and MB = G1/4"  
 Lifting thread for disassembly M12

8

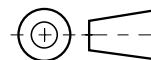
**Suction port SP:** Contact Parker for installation recommendation.

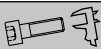

NG	Bolt kit - 		NBR	Kit 	FPM
63	BK518 4x M30x160 ISO 4762-12.9	1775 Nm	SK-TEP063EN		SK-TEP063EV

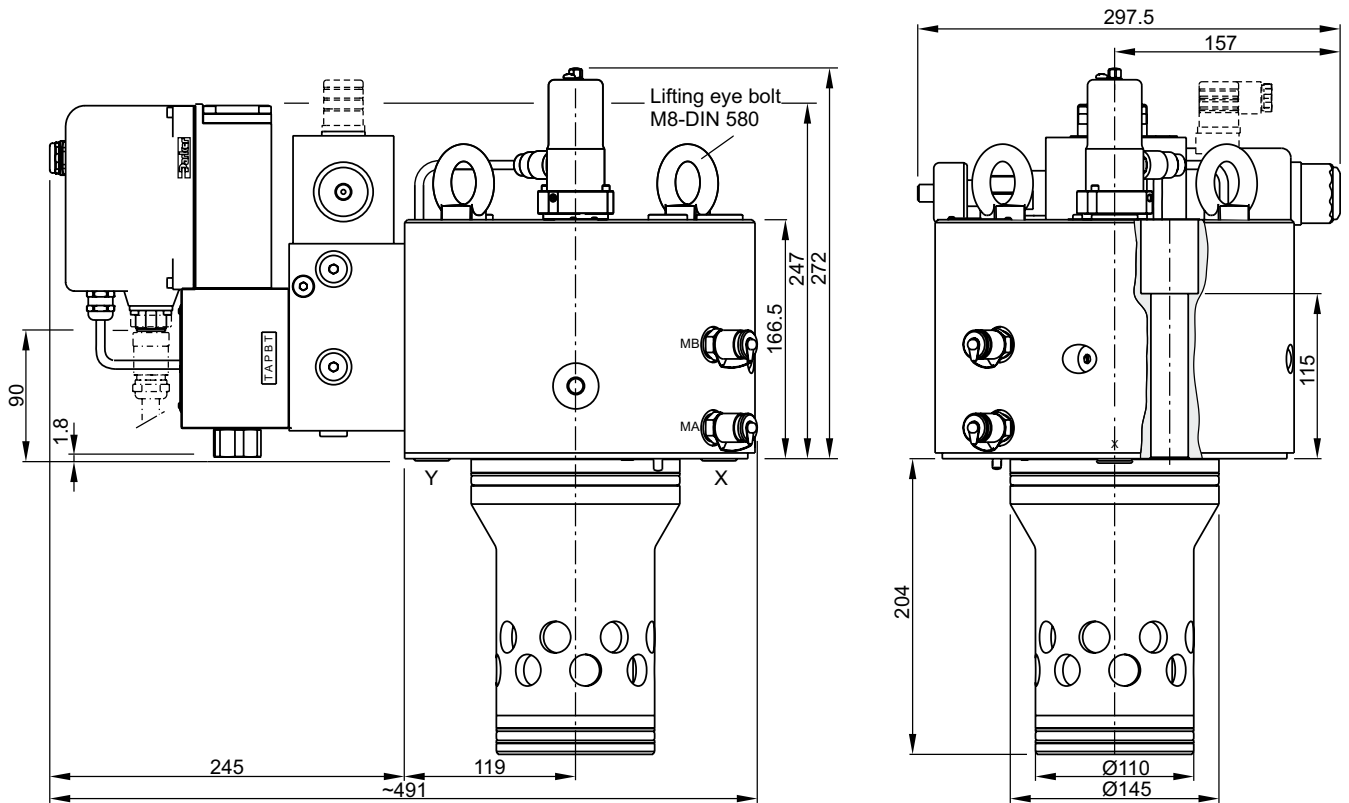
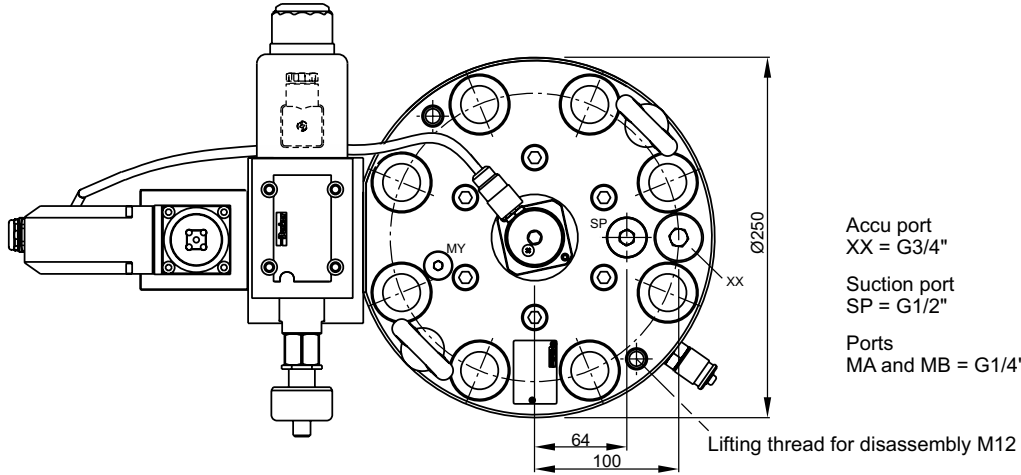

<sup>1)</sup> Please order female connector M12x1 separately (see accessories, directional control valves, female connector M12x1 (order no.: 5004109).

**NG80**

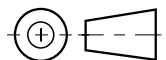

**Suction port SP:** Contact Parker for installation recommendation.



NG	Bolt kit - 		NBR	Kit	FPM
80	BK530 8x M24x160 ISO 4762-12.9	890 Nm	SK-TEP080EN		SK-TEP080EV

<sup>1)</sup> Please order female connector M12x1 separately (see accessories, directional control valves, female connector M12x1 (order no.: 5004109).

Dimensions

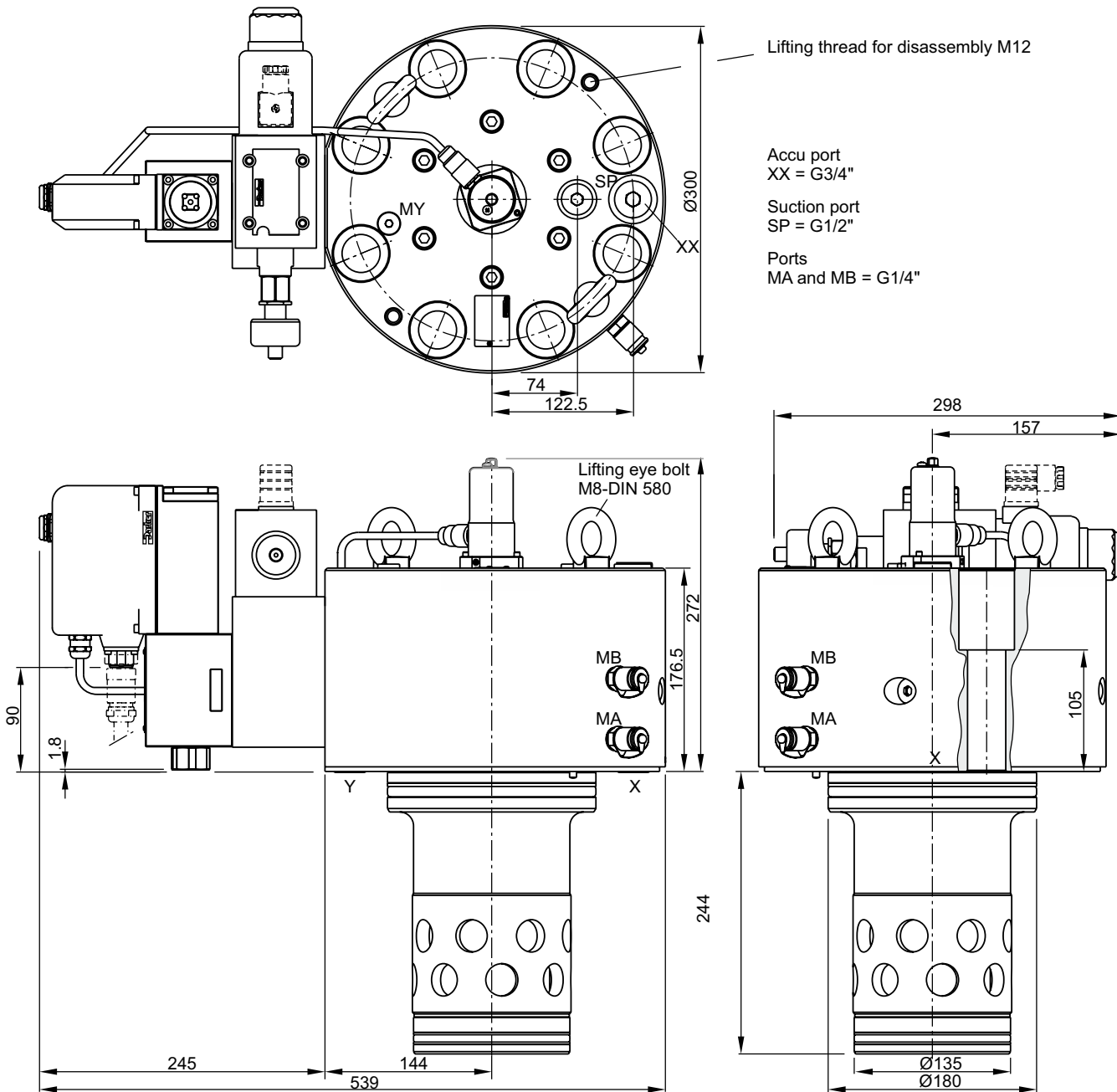

NG100

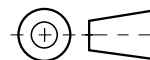

8

Suction port SP: Contact Parker for installation recommendation.

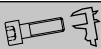

NG	Bolt kit - 		NBR	Kit	FPM
100	BK531 8x M30x150 ISO 4762-12.9	1775 Nm	SK-TEP100EN		SK-TEP100EV

<sup>1)</sup> Please order female connector M12x1 separately (see accessories, directional control valves, female connector M12x1 (order no.: 5004109).

**Code: ISO 7368-B\*-2-A/B**  
**NG25 to NG63**

**Code: ISO 7368-B\*-2-A**  
**NG80 to NG100**

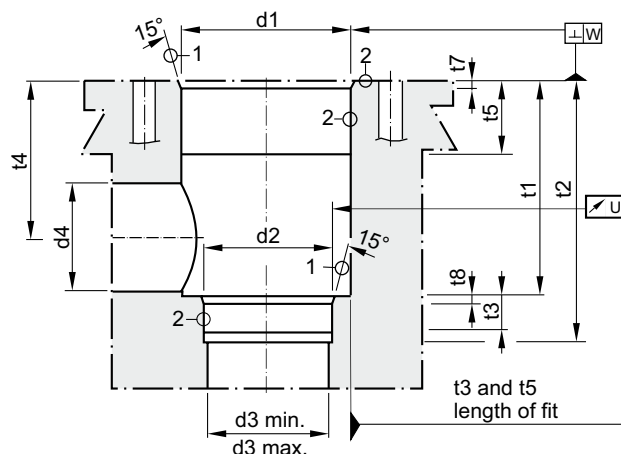
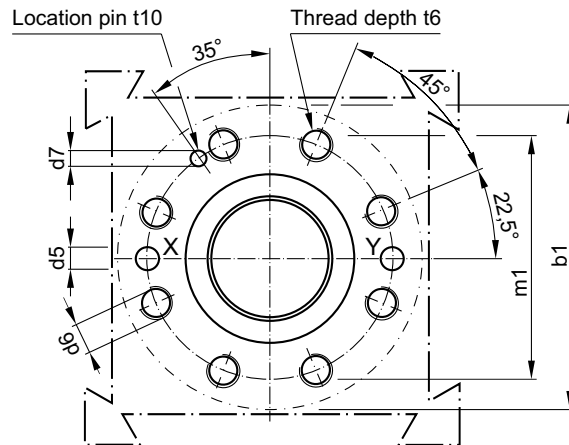
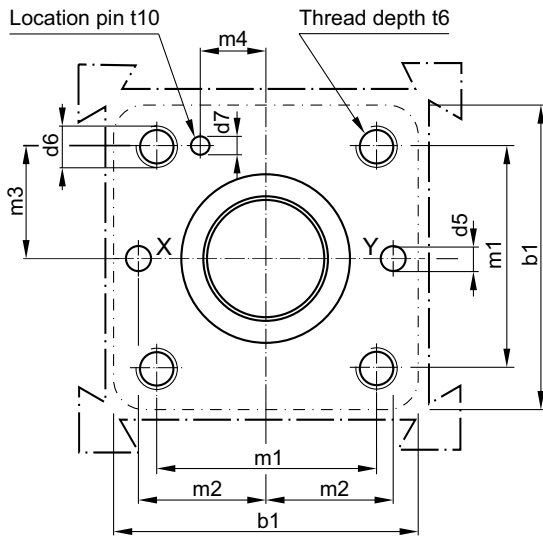

Required surface finish:

① =  $\sqrt{R_{\max} 16}$ , ② =  $\sqrt{R_{\max} 8}$

Deviating from ISO 7368 it is advisable to increase the diameters d3, d4 and d5.

Size	b1	d1 H7	d2 H7	d3 / d4	d3 max	d4 max <sup>1)</sup>	d5	d6	d7 H13	m1±0.2	m2±0.2	m3±0.2
25	85	45	34	25	27	32	6	M 12	4	58	33	29
32	102	60	45	32	44	50	8	M 16	6	70	41	35
40	125	75	55	40	54	63	10	M 20	6	85	50	42.5
50	140	90	68	50	67	80	10	M 20	8	100	58	50
63	180	120	90	63	89	100	12	M 30	8	125	75	62.5
80	250	145	110	80	109	110	16	M 24	10	200	—	—
100	300	180	135	100	134	150	20	M 30	10	245	—	—

Size	m4±0.2	t1+0.5	t2+1	t3	t4	t4 max <sup>1)</sup>	t5	t6	t7	t8	t10	U	W
25	16	58	72	12	44	40.5	30	35	25	25	10	0.03	0.05
32	17	70	85	13	52	44	15	35	2.5	2.5	10	0.03	0.1
40	23	87	105	15	64	54	15	45	3	3	10	0.05	0.1
50	30	100	122	17	72	59	17	45	4	3	10	0.05	0.1
63	38	130	155	20	95	78	19	65	4	4	10	0.05	0.2
80	—	175	205	25	130	115	32	50	5	5	10	0.05	0.2
100	—	210	245	29	155	133	32	53	5	5	10	0.05	0.2

<sup>1)</sup> d4max only in combination with t4max.