

The 2-way servo proportional valves with VCD technology valves series TDP are used in applications where high flow has to be precisely controlled at maximum dynamics. Typical applications are die casting, injection moulding and hydraulic presses.

Function

The 2-way servo proportional valves TDP have a 2-stage design consisting of a DFplus pilot valve and a main stage with poppet and LVDT.

With the DFplus pilot valve the TDP achieves extremely fast response times: from 10.5 ms (NG25) up to 28 ms (NG100) with an accuracy of <0.1 % of the nominal flow. The pilot valve actively controls the poppet - independent of the pressure conditions in the main ports. It is basically required that the pilot pressure is at the level of the system pressure. At low system pressure the pilot pressure should be min. 140 bar, when high valve dynamics are desired. The integrated electronics in the pilot of the TDP has two control loops for the main poppet and the pilot spool.



TDP040

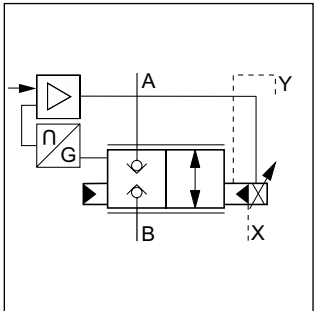

Features

- Active pilot operated 2-way servo proportional valve
- Cavity and mounting pattern according to ISO 7368
- Fast step response
- Flow direction B to A and A to B
- Completely mounted and adapted unit with integrated electronics
- In order to ensure the closed position, pilot pressure is required
- IO-Link interface for parametrizing
- RGB diode for optical status check
- NFC interface
- 7 sizes, NG25 up to NG100



TDP040

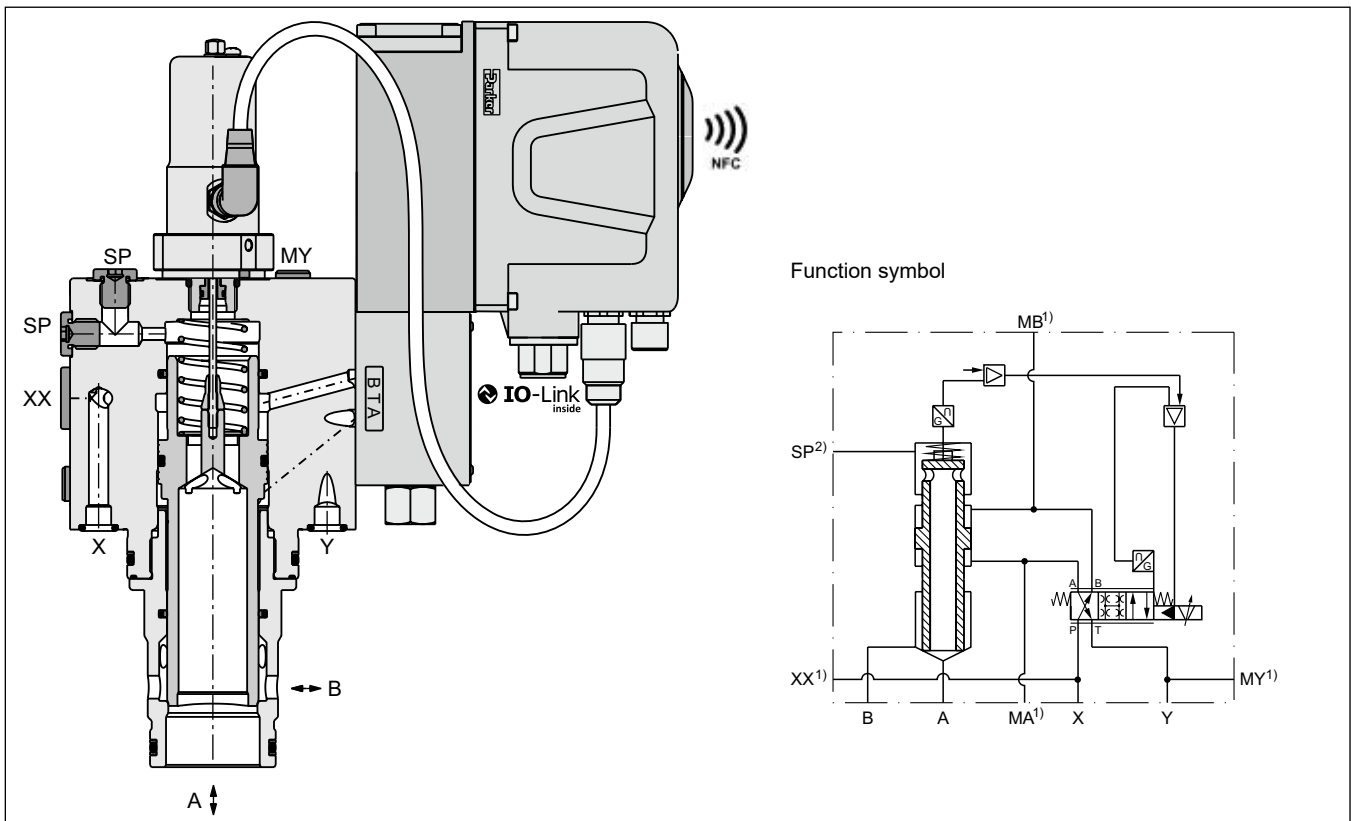

Function symbol

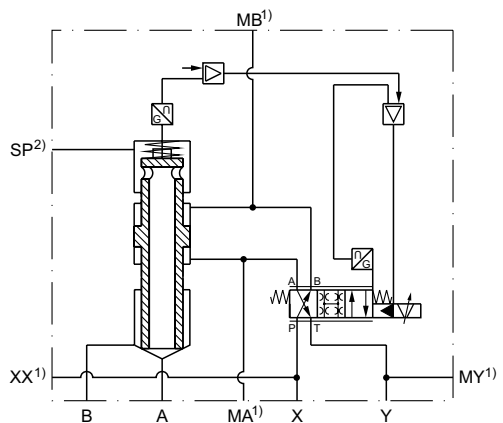

¹⁾ NG25 and NG32 without accu port XX and without port MA, MB and MY.
²⁾ NG25 without suction port SP.

Ordering Code / Performance Curves

Ordering code

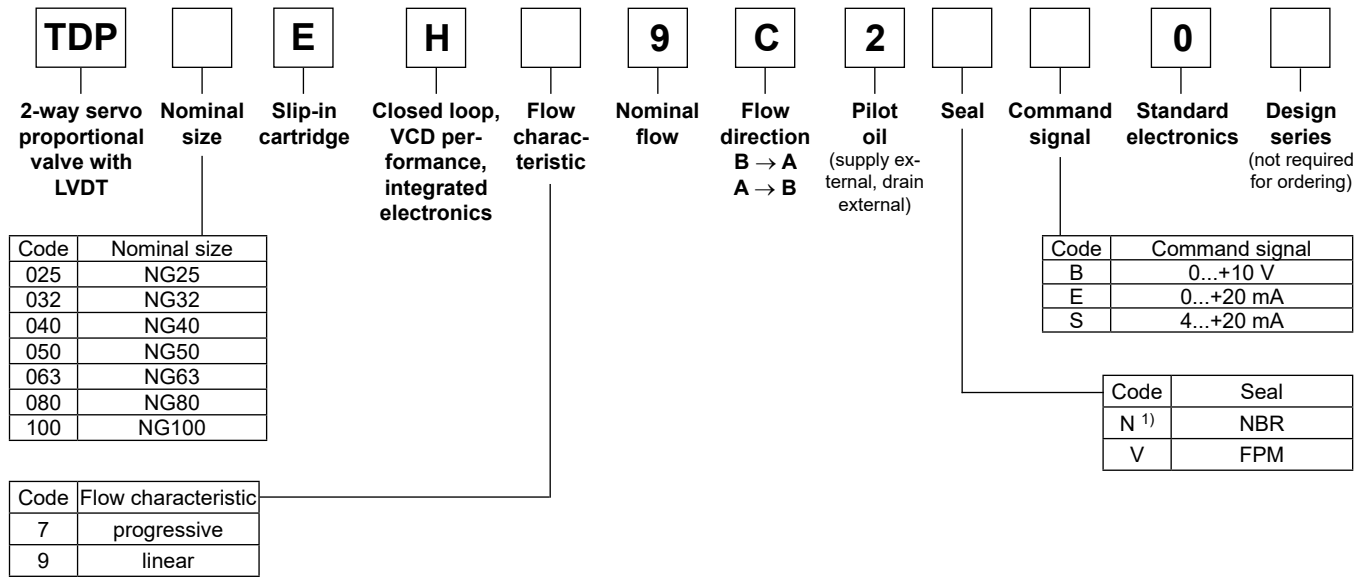

¹⁾ HFC fluids suitable

The DFplus pilot valve is also available with EtherCAT interface, see chapter 3, D*FP and D*1FP with EtherCAT. Please order connector separately. Angle female connector must be used for NG25 to NG50. IO-LINK-MASTER-USB ordering no. 40983544

8

Characteristic flow/signal line, Δp = 5 bar
Linear (code 9)

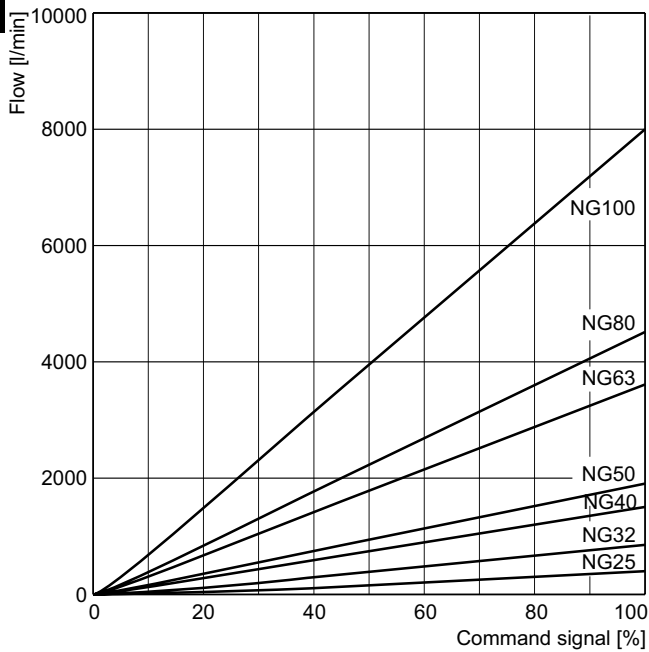

Progressive (code 7 for TDL replacement)

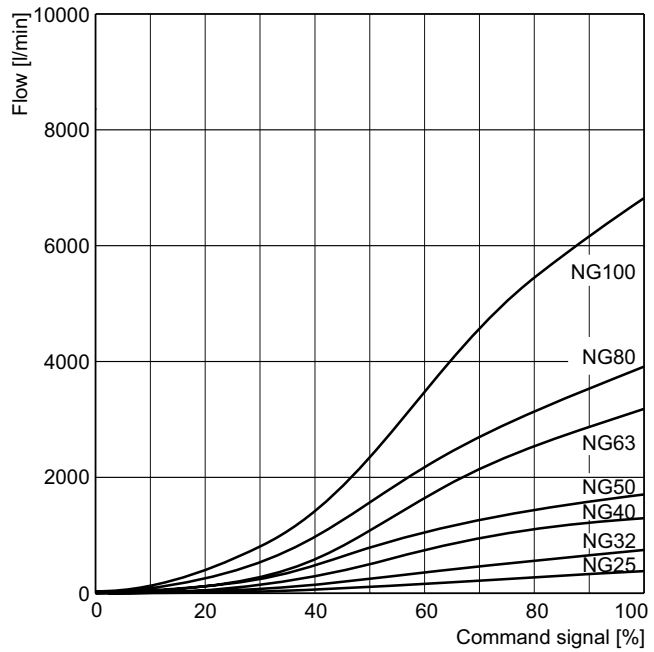

Opening point factory set to 3 %

$$\text{Flow at different } \Delta p \quad Q_{\text{actual}} = Q_{\text{nominal}} \cdot \sqrt{\Delta p_{\text{actual}} / \Delta p_{\text{nominal}}}$$

Characteristic curve measured with HLP46 at 50 °C.

General		Proportional throttle valve with LVDT and integrated electronics, slip-in cartridge according to ISO 7368							
Design		to ISO 7368							
Nominal size	DIN	NG25	NG32	NG40	NG50	NG63	NG80	NG100	
Mounting position		unrestricted							
Ambient temperature	[°C]	-20...+60							
Weight	[kg]	11	13	15	26	52	105	157	
Vibration resistance	[g]	10 sinus 5...2000 Hz acc. IEC 60068-2-6 10 (RMS) random noise 20...2000 Hz acc. IEC 60068-2-64 15 shock acc. IEC 60068-2-27							
Hydraulic									
Max. operating pressure	[bar]	Ports A, B, X and SP up to 350, XX observe accumulator pressure rating; port Y: max. 35							
Fluid		Hydraulic oil according to DIN 51524							
Fluid temperature	[°C]	-20...+60 (NBR: -25...+60)							
Viscosity	recommended [cSt] / [mm²/s] permitted [cSt] / [mm²/s]	30 ... 80 20 ... 400							
Filtration		ISO 4406; 18/16/13							
Nominal flow at Δp = 5 bar (linear)	[l/min]	420	850	1500	1900	3600	4500	8000	
Recommended max. flow (linear)	[l/min]	800	2000	3000	4500	8000	13000	20000	
Nominal flow at Δp = 5 bar (progressive)	[l/min]	380	750	1300	1700	3200	3900	6800	
Recommended max. flow (progressive)	[l/min]	700	1750	2600	4000	7000	11250	17000	
Flow direction		B to A / A to B							
Pilot pressure	[bar]	must be as high as system pressure							
Pilot oil	supply drain	external via X external via Y							
Leakage in pilot valve at 100 bar	[ml/min]	< 400							
Pilot valve size		NG06				NG10			
Max. pilot flow at 140 bar pilot pr.	[l/min]	23	30	40	40	70	80	100	
Static/dynamic (for optimal dynamics see installation recommendation)									
Step response at pilot press. >140 bar	[ms]	10.5	12	14	20	17	23	28	
Frequency response at pilot press. >140 bar									
Amplitude -3 dB; 10 % ±5 %	[Hz]	95	80	74	66	52	46	41	
Phase -90°; 10 % ±5 %	[Hz]	85	63	59	52	56	51	47	
Hysteresis	[%]	< 0.1							
Sensitivity	[%]	< 0.05							
Temperature drift	[%/K]	< 0.025							
Interfaces									
IO-Link		IEC 61131-9							
NFC		ISO/IEC 15693; Frequency 13.56 MHz; -27.2 dBμA/m at 10 distances NFC Forum Type 5 tag certified by the NFC Forum							
Electrical characteristics									
Duty ratio	[%]	100							
Protection class		IP65 in accordance with EN 60529 (with correctly mounted plug-in connector) 6 = Full protection against contact, dust tight 5 = Protection against water jets (nozzle) from any angle							
Supply voltage/ripple	[V]	24 nominal (tolerance range 22 ... 30), electric shut-off at < 19, ripple < 5 % eff., surge free							
Current consumption max.	[A]	3.5							
Pre-fusing	[A]	4.0 medium lag							
Input signal									
Code B	Voltage [V] Impedance [kOhm]	10...0...-10, ripple <0.01 % eff., surge free 100							
Code E	Current [mA] Impedance [Ohm]	20...0...-20, ripple <0.01 % eff., surge free <250							
Code S	Current [mA] Impedance [Ohm]	4...12...20, ripple <0.01 % eff., surge free <3.6 mA = disable, >3.8 mA = according to NAMUR NE43 <250							
Differential input max.	[V]	30 for terminal D and E against PE (terminal G) 11 for terminal D and E against 0V (terminal B)							
Enable signal		acc. EN 61131-2; Type 3							
Diagnostic signal	[V]	Low -3...+5; High 11...30; input current 3 mA							
EMC		+10...0...-10							
Electrical connection		EN 61000-6-2, EN 61000-6-4							
Wiring min.	[mm²]	6 + PE acc. EN 175201-804							
Wiring length max.	[m]	7 x 1.0 (AWG16) overall braid shield 50							

Installation Recommendations / Electronics

Installation recommendations

An insufficient pilot oil supply (e.g. due to long distances and/or small diameters) can negatively influence the dynamics of the TDP valve.

To avoid this, an accumulator can be connected to port XX at the valve body of the TDP. A short-term undersupply with pilot oil can be compensated via this accumulator.

Sizing data: see operation manual.

Please also consider the Parker accumulator product range and the Parker Accumulator Sizing Software.

Block circuit diagram electronics

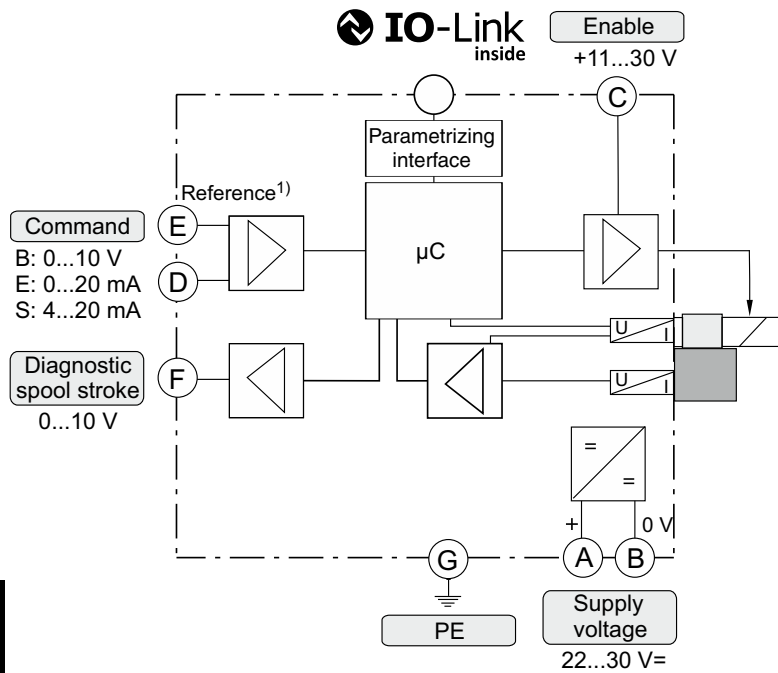

Connection diagrams electronics

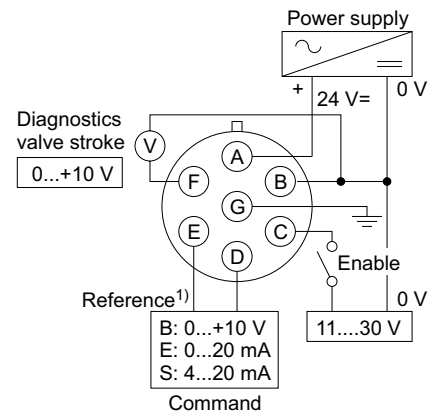

8

Female connector for NG63 to NG100 (EMC conform)

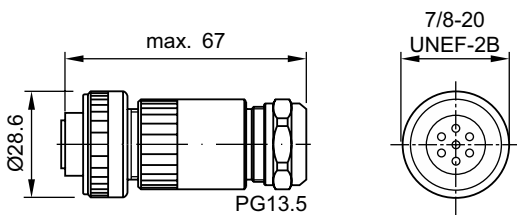

ID no. 5004072

Please order plugs separately.

Pin assignment IO-Link (parametrizing) interface, M12 socket

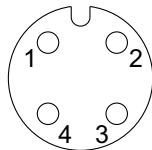

PIN assignment acc. IEC 60974-5-2

- Pin 1: 24 VDC
- Pin 3: GND
- Pin 4: IO-Link Communication (C/Q)

¹⁾ Do not connect with the supply voltage zero.

Angle female connector for NG25 to NG50 (EMC conform)

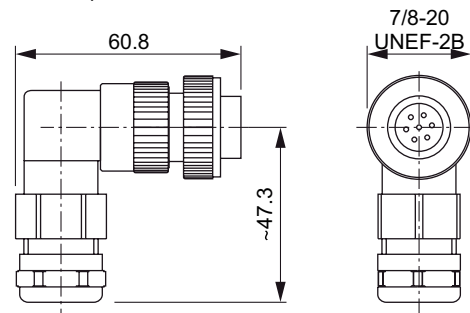

ID no. 5005160

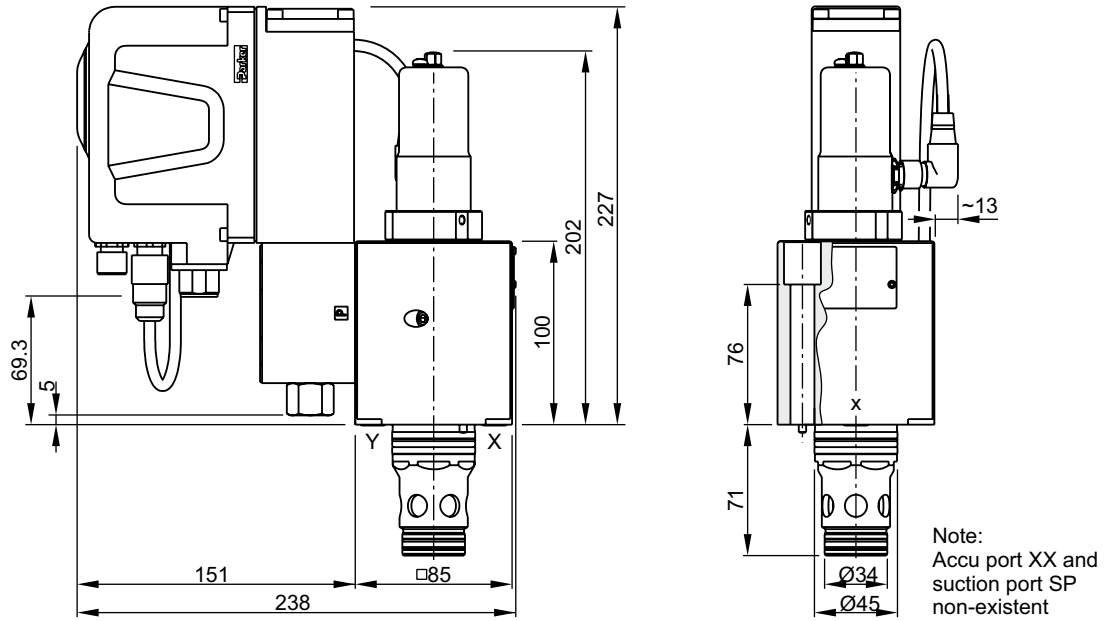

NG25

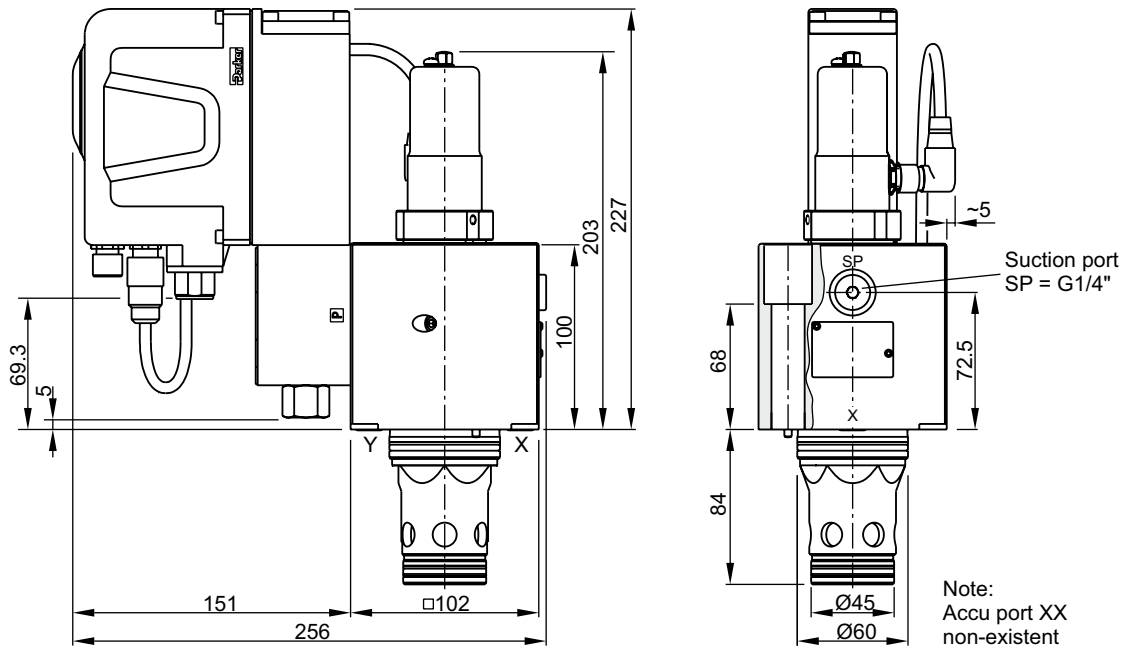

NG32



Suction port SP: Contact Parker for installation recommendation.

NG	Bolt kit - 		NBR	 Kit	FPM
25	BK504 4 x M12x100 ISO 4762-12.9	108 Nm	SK-TDP025EN30		SK-TDP025EV30
32	BK529 4 x M16x100 ISO 4762-12.9	264 Nm	SK-TDP032EN30		SK-TDP032EV30

NG40

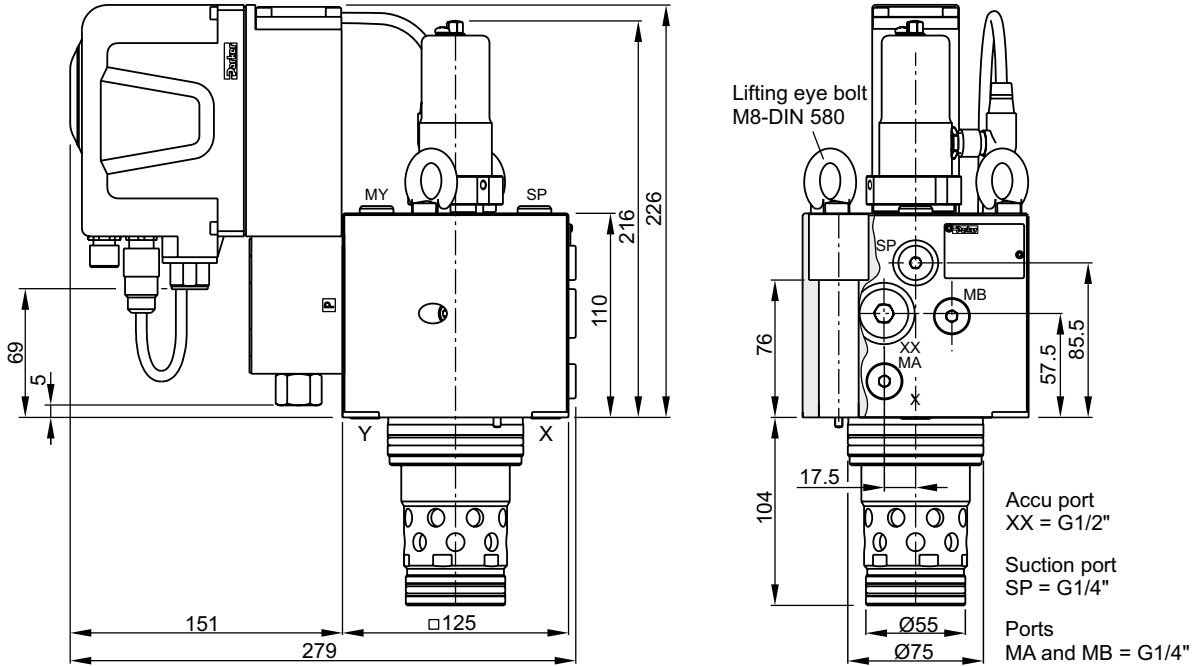

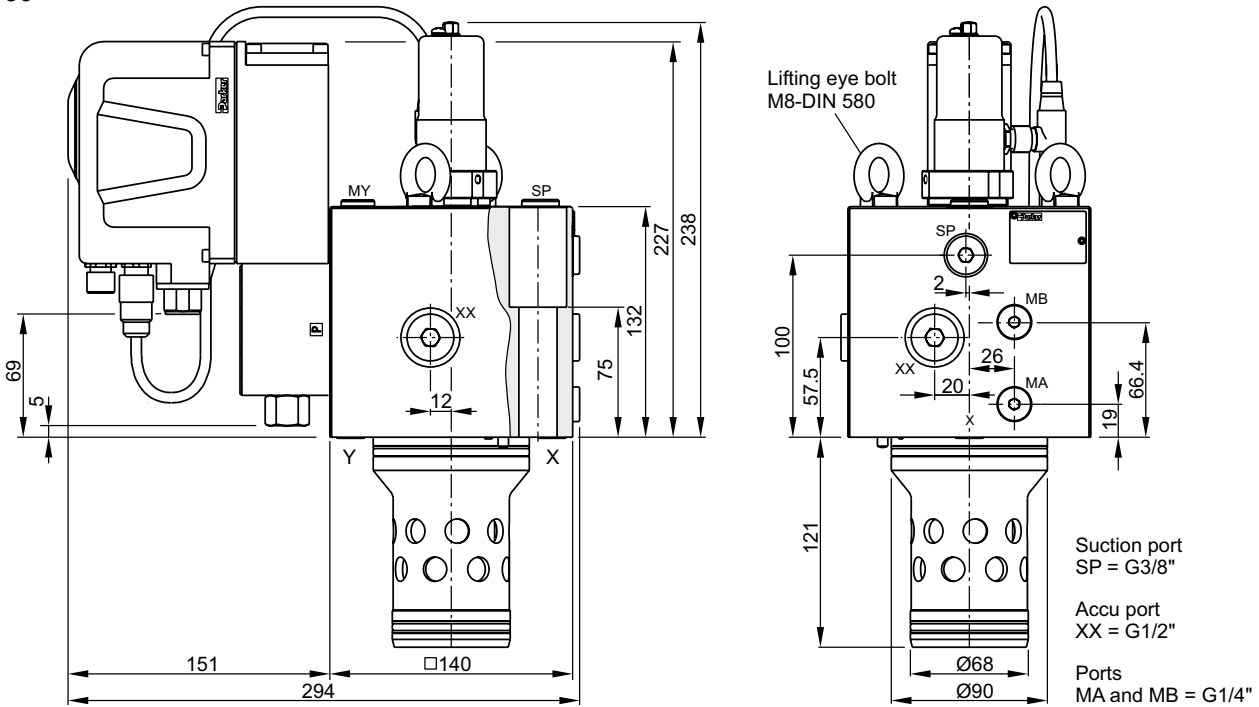

NG50

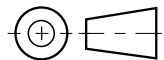

Lifting thread for disassembly M12



Suction port SP: Contact Parker for installation recommendation.

NG	Bolt kit - 		NBR	 Kit	FPM
40	BK481 4 x M20x110 ISO 4762-12.9	517 Nm	SK-TDP040EN30		SK-TDP040EV30
50	BK481 4 x M20x110 ISO 4762-12.9	517 Nm	SK-TDP050EN30		SK-TDP050EV30

NG63

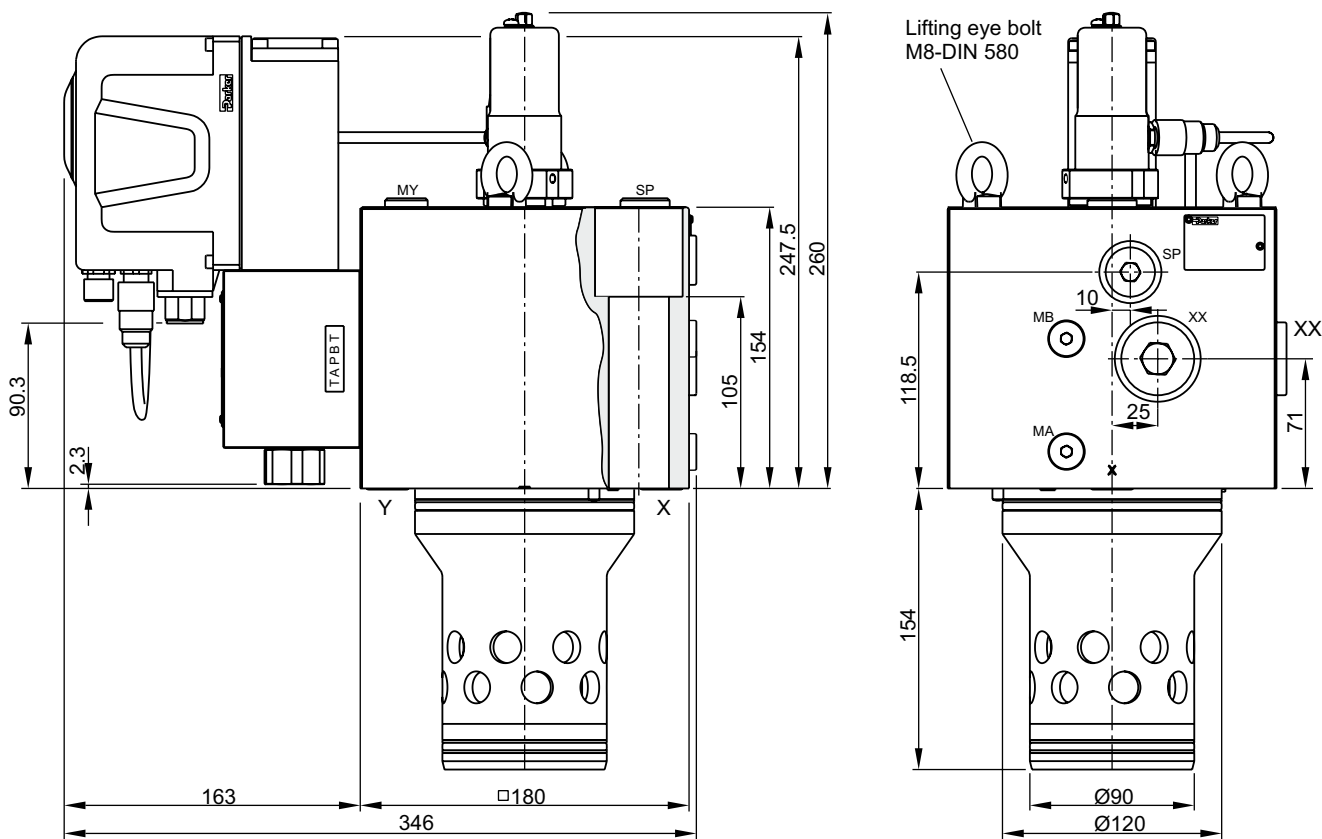





Suction port Accu port Ports
 SP = G1/2" XX = G3/4" MA and MB = G1/4"

Lifting thread for disassembly M12

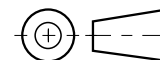

Suction port SP: Contact Parker for installation recommendation.





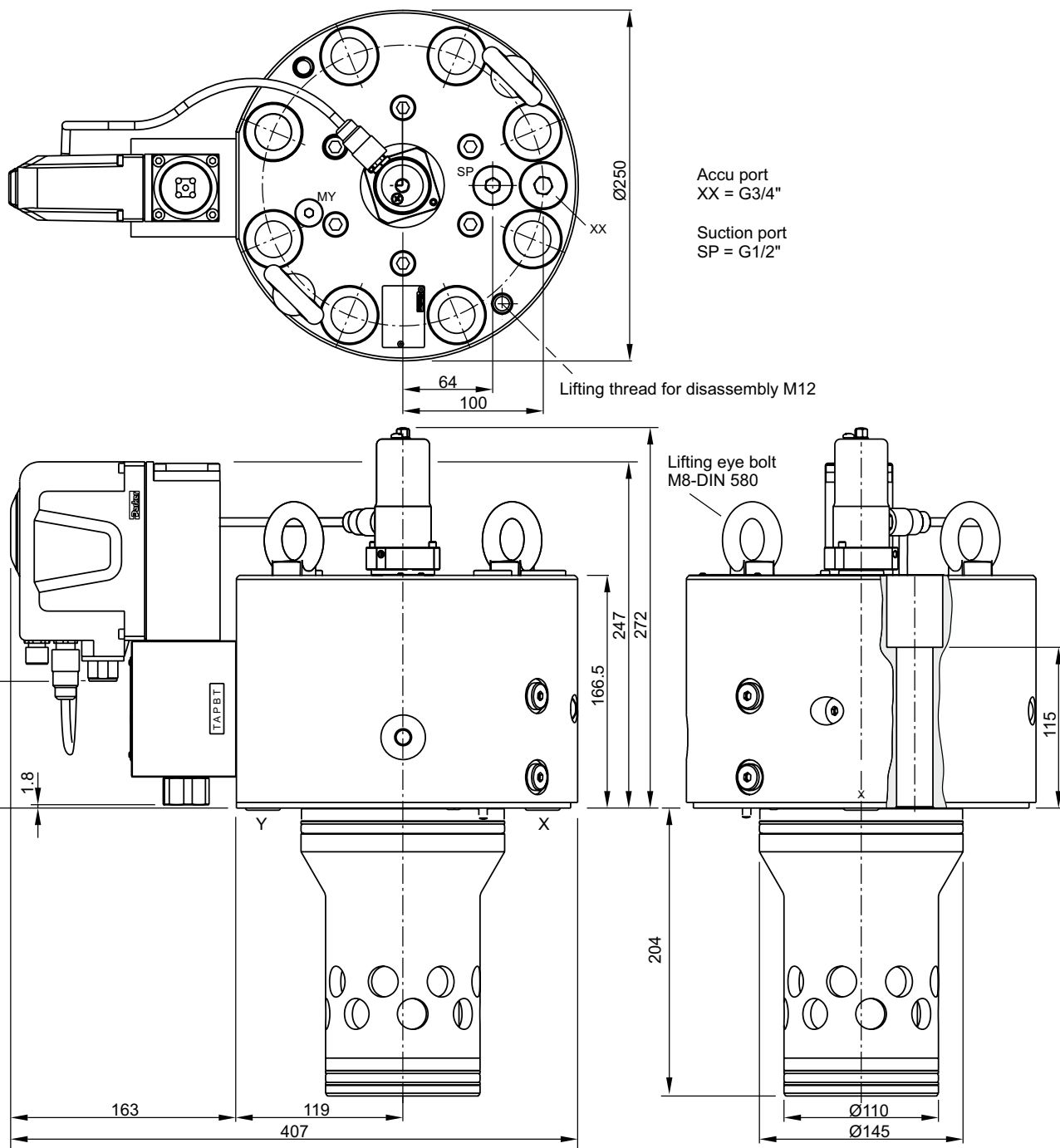

NG	Bolt kit - 		NBR	 Kit	FPM
63	BK518 4 x M30x160 ISO 4762-12.9	1775 Nm	SK-TDP063EN30		SK-TDP063EV30

NG80

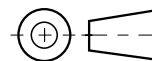

Suction port SP: Contact Parker for installation recommendation.



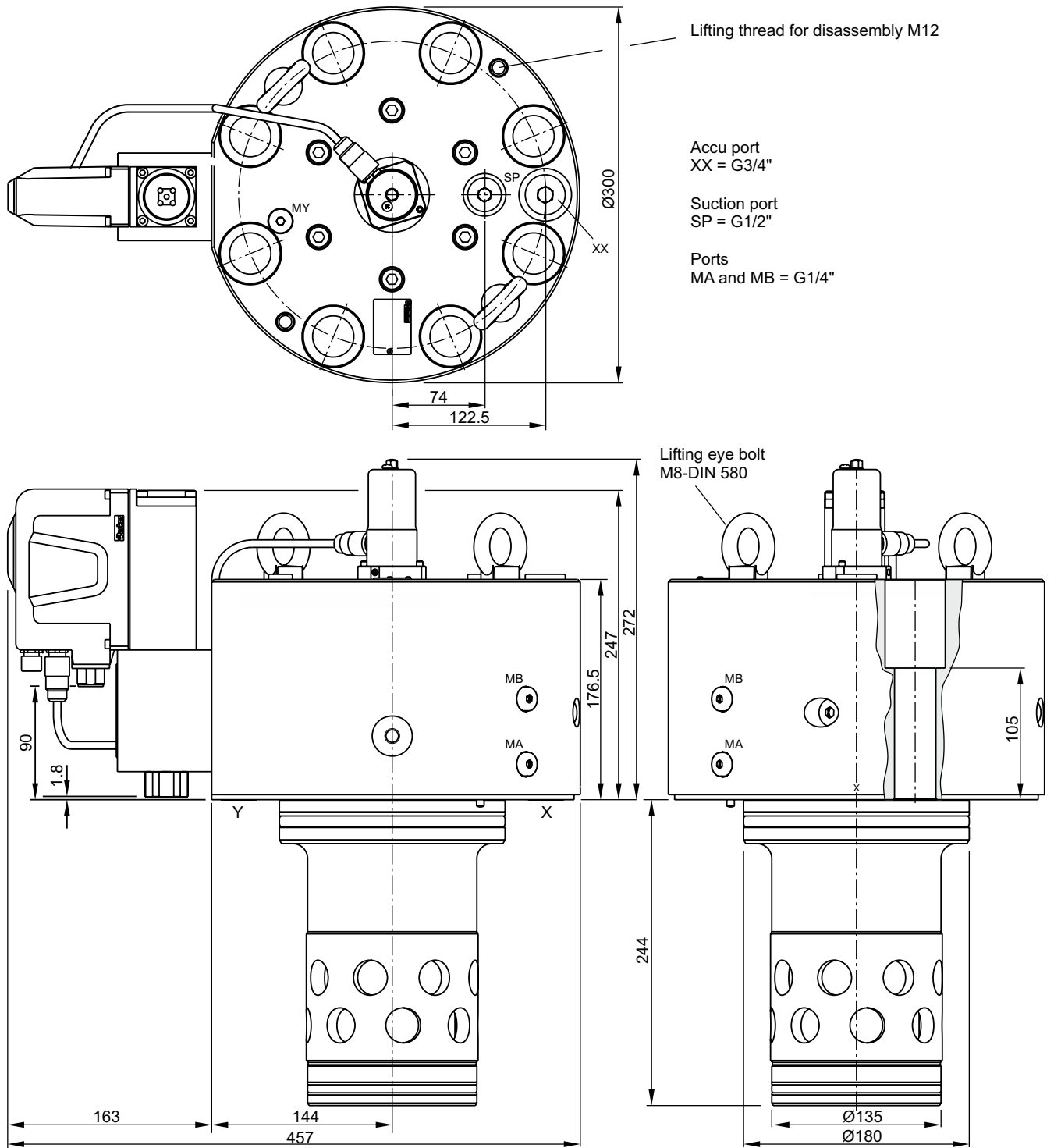

NG	Bolt kit - 		NBR	 Kit	FPM
80	BK530 8x M24x160 ISO 4762-12.9	890 Nm	SK-TDP080EN30		SK-TDP080EV30

NG100



Suction port SP: Contact Parker for installation recommendation.

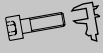

NG	Bolt kit - 		NBR	 Kit	FPM
100	BK531 8x M30x150 ISO 4762-12.9	1775 Nm	SK-TDP100EN30		SK-TDP100EV30

Dimensions

Code: ISO 7368-B*-*-2-A/B

Code: ISO 7368-B*-*-2-A

NG25 to NG63

NG80 to NG100

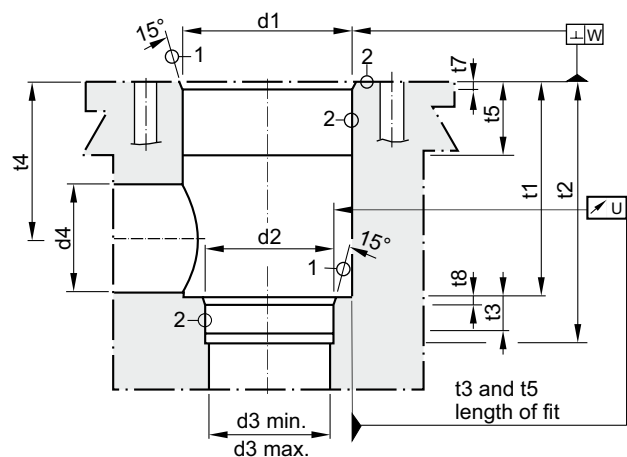
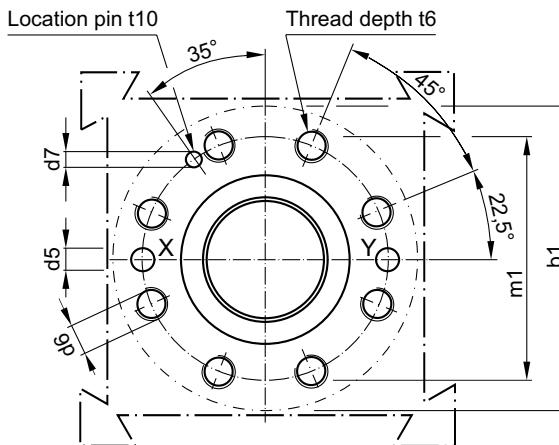
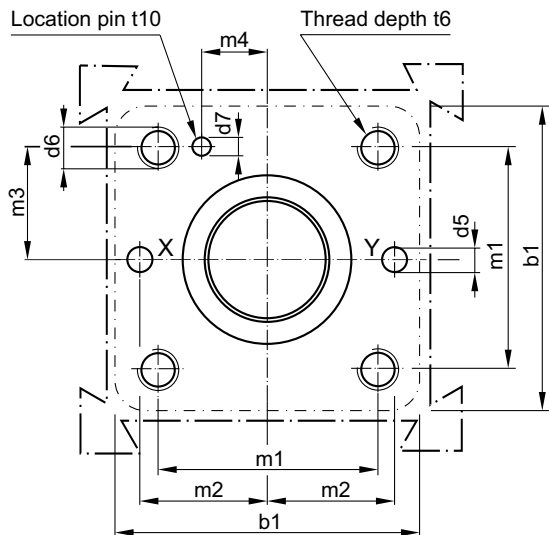

Required surface finish:

① = $\sqrt{R_{\max} 16}$, ② = $\sqrt{R_{\max} 8}$

Deviating from ISO 7368 it is advisable to increase the diameters d3, d4 and d5.

Size	b1	d1 H7	d2 H7	d3	d3 max	d4 max ¹⁾	d5 max	d6	d7 H13	m1±0.2	m2±0.2	m3±0.2
25	85	45	34	25	27	32	6	M12	4	58	33	29
32	102	60	45	32	44	50	8	M 16	6	70	41	35
40	125	75	55	40	54	63	10	M 20	6	85	50	42.5
50	140	90	68	50	67	80	10	M 20	8	100	58	50
63	180	120	90	63	89	100	12	M 30	8	125	75	62.5
80	250	145	110	80	109	110	16	M 24	10	200	—	—
100	300	180	135	100	134	150	20	M 30	10	245	—	—

Size	m4±0.2	t1+0.5	t2+1	t3	t4	t4 max ¹⁾	t5	t6	t7	t8	t10	U	W
25	16	58	72	12	44	40.5	30	35	25	25	10	0.03	0.05
32	17	70	85	13	52	44	15	35	2.5	2.5	10	0.03	0.1
40	23	87	105	15	64	54	15	45	3	3	10	0.05	0.1
50	30	100	122	17	72	59	17	45	4	3	10	0.05	0.1
63	38	130	155	20	95	78	19	65	4	4	10	0.05	0.2
80	—	175	205	25	130	115	32	50	5	5	10	0.05	0.2
100	—	210	245	29	155	133	32	53	5	5	10	0.05	0.2

¹⁾ Only in combination with d4max and t4max.