

Characteristics

Hydraulically pilot operated check valves allow free flow from A to B. The counter-flow direction is blocked.

When pressure is applied to control port X, the ring chamber flow from B to A is released. The pilot control ratio is 6:1.

Function

When no pressure is applied to the X-port, the flow from B to A is blocked, because the pressure in B is also effective on top of the poppet.

Pressurizing the X-port relieves the area on top of the poppet to the drain port and allows flow from B to A. The seat design of the SVLB valve series provides leak-free separation of port A and B in the closed position.

Features

- Pilot operated check valve
- Cavity and mounting pattern acc. to ISO 7368
- Dampening poppet optional
- 5 sizes NG16 to NG50

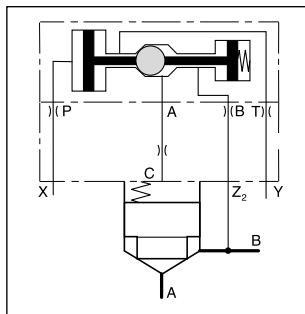
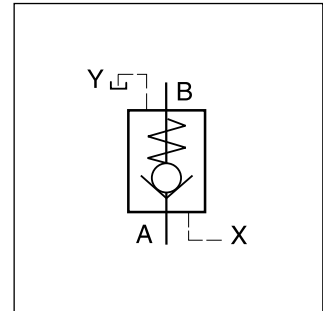

8

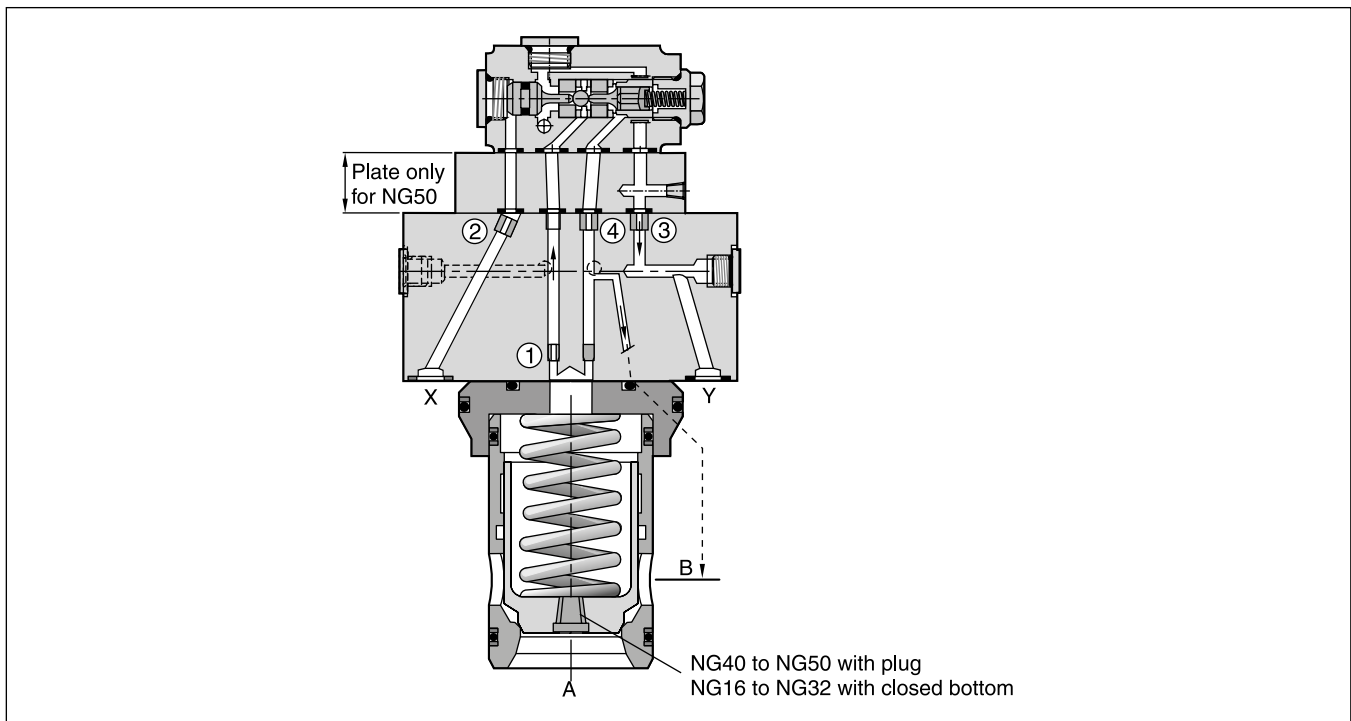

Ordering code

	SVL	B	10		6	E			
Seal	Hydr. operated check valve	Slip-in mounting	Design style acc. to ISO 7368	Poppet type	Pilot control ratio 6:1	Slip-in cartridge valve	Valve size	Closing spring	Design series (not required for ordering)

Code	Seal
omit	NBR
V	FPM

Code	Spring
N	0.5 bar
S	1.6 bar
T	2.5 bar
U	4.0 bar

Code	Poppet type
4	04
8 ¹⁾	08

Code	Size
16	NG16
25	NG25
32	NG32
40	NG40
50	NG50

Bold letters = Short-term availability

Technical data

General		NG16	NG25	NG32	NG40	NG50
Nominal size						
Interface		Slip-in mounting acc. ISO 7368				
Mounting position		unrestricted				
Ambient temperature	[°C]	-20...+60				
MTTF _D value	[years]	75				
Weight	[kg]	2.3	3.2	4.6	7.8	12.0
Hydraulics						
Max. operating pressure	[bar]	350				
Nominal flow	[l/min]	250	450	900	1300	1800
Fluid		Hydraulic oil according to DIN 51524				
Fluid temperature	[°C]	-20...+70 (NBR: -25...+70)				
Viscosity, permitted	[cSt] / [mm ² /s]	20...400				
Viscosity, recommended	[cSt] / [mm ² /s]	30...80				
Filtration		ISO 4406 (1999); 18/16/13				

Δp/Q flow curve

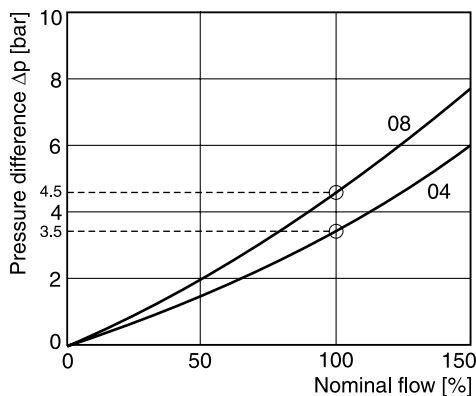

Poppet type 04, 08, without spring.

All characteristic curves measured with HLP46 at 50 °C.

¹⁾ With damping nose.

Standard orifices

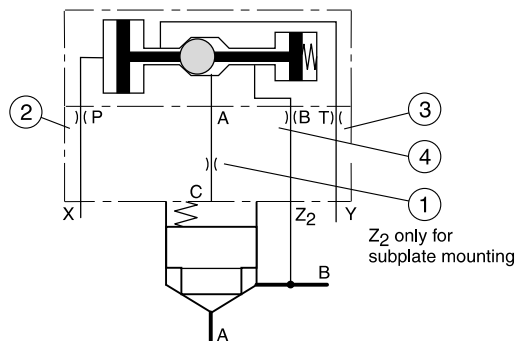

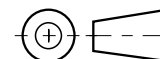
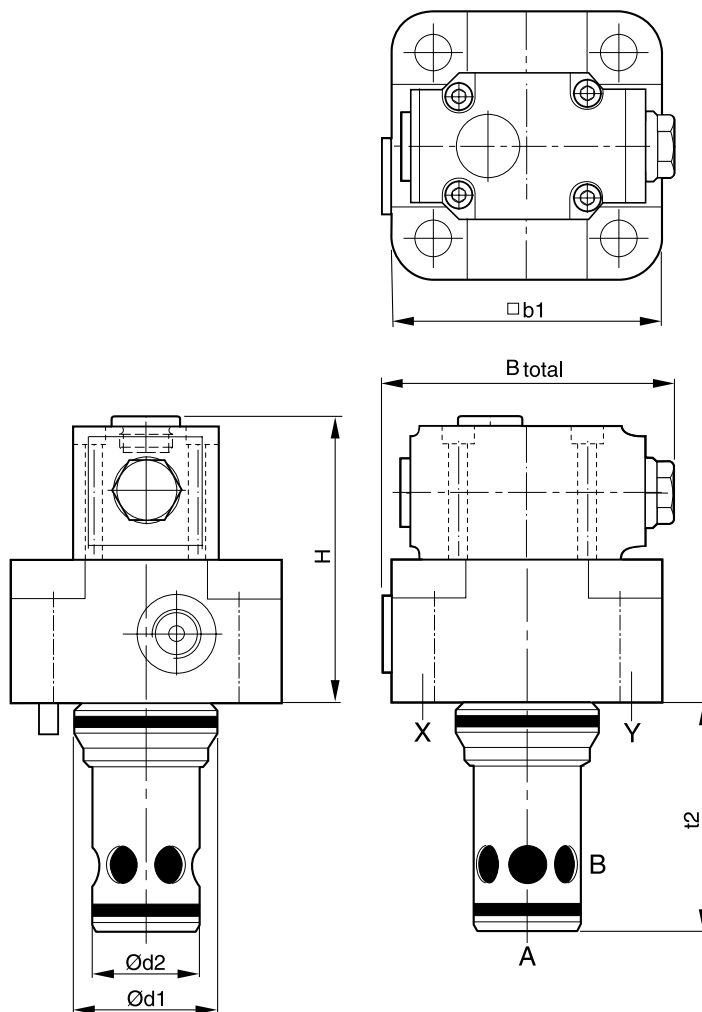

Pos.	E16	E25	E32	E40	E50
1	open (M5)	open (M5)	open (M5)	open (M5)	open (M6)
2	Ø1.2 (M5)	Ø1.2 (M6)	Ø1.2 (M6)	Ø1.2 (M6)	Ø1.2 (M8)
3	open (M5)	open (M6)	open (M6)	open (M6)	open (M8)
4	Ø1.0 (M5)	Ø1.2 (M5)	Ø1.3 (M5)	Ø1.5 (M6)	Ø2.0 (M6)

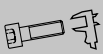

8

Size	16	25	32	40	50
H	84	88	93	103	138
b1	79*	85	102	125	140
d1 ^{H7}	32	45	60	75	90
d2 ^{H7}	25	34	45	55	68
t2 ^{+0.1}	56	72	85	105	122
Bges.	99	94	103	133	148

NG	Kit	 ISO 4762-12.9	 [Nm]	 Kit	
				NBR	FPM
16	BK441	4x M8x50	31.8	SK-SVLB10E16	SK-SVLB10E16V
25	BK391	4x M12x50	108	SK-SVLB10E25	SK-SVLB10E25V
32	BK415	4x M16x55	264	SK-SVLB10E32	SK-SVLB10E32V
40	BK416	4x M20x70	517	SK-SVLB10E40	SK-SVLB10E40V
50	BK417	4x M20x75	517	SK-SVLB10E50	SK-SVLB10E50V

* Width 65 mm.