

Characteristics

The proportional pressure relief valve series RE*E*W consists of a proportional pilot stage and a slip-in cartridge main stage. A mechanical maximum pressure stage is optionally available. For sizes NG25, NG32 and NG40 a screw-in cartridge is used, for sizes NG50 and NG63 an additional sandwich unit.

The RE*W model code embraces the pilot valves, covers and cartridges that are also offered as separate items. See combination examples for details.

In combination with the digital power amplifier PC-D00A-400 the valve parameters can be saved, changed and duplicated.

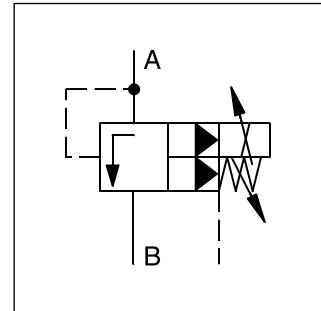

Features

- Pilot operated with proportional solenoid
- Continuous adjustment by proportional solenoid
- Optional mechanical max. pressure stage
- Cavity and mounting pattern according to ISO 7368
- 4 pressure stages
- 6 sizes, NG16 to NG63

Note

Port X only usable for remote control.

8

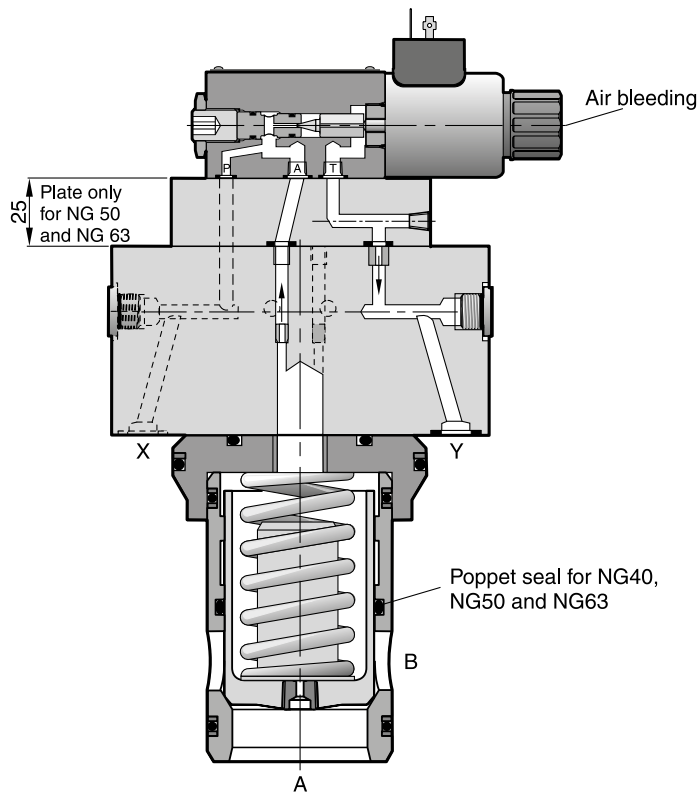

Ordering Code / Technical Data

Ordering code

RE		E		W	1	S		1		W			
Prop. pressure relief valve	Nominal size	Slip-in mounting ISO 7368	Pressure stages	Off-board electronics	Pilot oil (pilot int., drain ext.)	Poppet spring	Seal	Normally open	Solenoid	Without plug	Options	Design series	Spool type

Code	Nominal size
16	NG16
25	NG25
32	NG32
40 ¹⁾	NG40
50 ¹⁾	NG50
63 ¹⁾	NG63

Code	Pressure stages
10	up to 105 bar
17	up to 175 bar
25	up to 250 bar
35	up to 350 bar

Code	Spool type
omit	Standard
S07	with poppet seals

Code	Options
omit	Standard
M	Mech. max. adjustment

Code	Solenoid
K	12 V, 2.1 A
X	16 V, 1.3 A

Code	Seal
N	NBR
V	FPM

¹⁾ With poppet seal.

Technical data

General							
Nominal size		NG16	NG25	NG32	NG40	NG50	NG63
Interface	Slip-in mounting acc. ISO 7368						
Mounting position	as desired, horizontal mounting preferred						
Ambient temperature	[°C]	-20...+60					
MTTF _D value	[years]	75					
Weight	[kg]	2.7	5.2	6.4	9.5	15.2	24.3
Hydraulic							
Max. operating pressure	[bar]	Ports A and X 350, ports B and Y 30					
Pressure stages	[bar]	105, 175, 250, 350					
Nominal flow	[l/min]	220	500	950	1400	2300	4000
Fluid	Hydraulic oil according to DIN 51524						
Fluid temperature	[°C]	-20...+70 (NBR: -25...+70)					
Viscosity, permitted	[cSt] / [mm ² /s]	20...400					
		30...80					
Filtration		ISO 4406 (1999); 18/16/13					
Electrical (proportional solenoid)							
Duty ratio	100 % ED; CAUTION: coil temperature up to 150 °C possible						
Protection class	IP65 in accordance with EN 60529 (with correctly mounted plug-in connector)						
Code		K			X		
Supply voltage	[V]	12 V =			16 V =		
Max. current	[A]	2.1			1.3		
Coil resistance at 20 °C	[Ohm]	4.28			12		
Solenoid connection	Connector as per EN 175301-803						
Power amplifier, recommended	PCD00A-400						

Signal/pressure curve

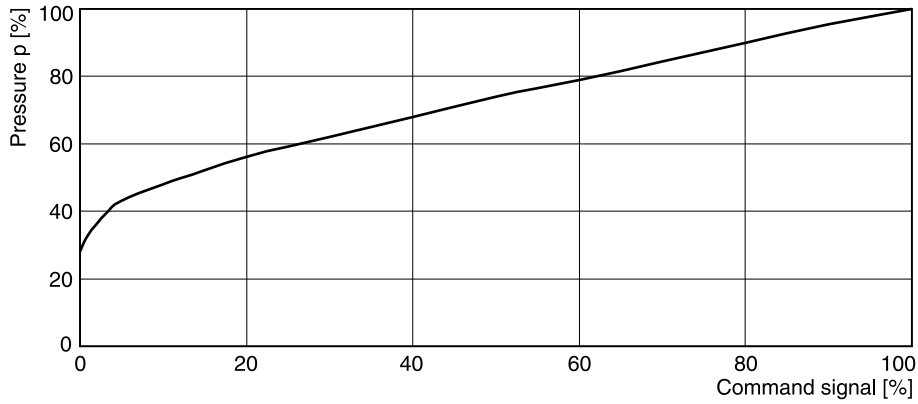

p/Q performance curve

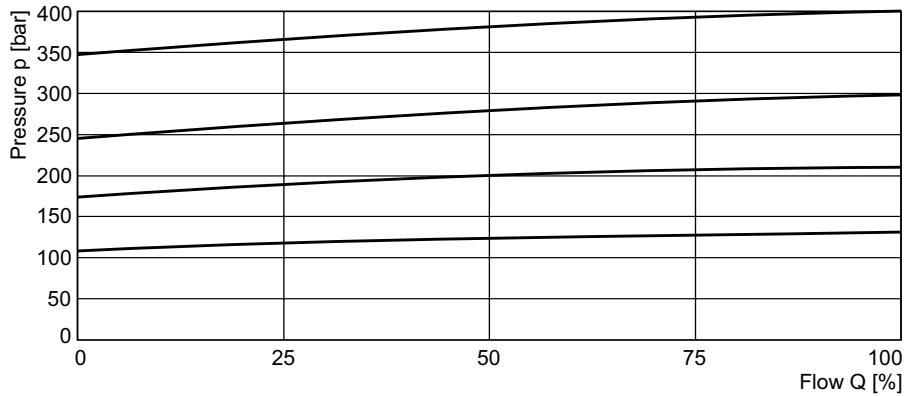

All characteristic curves measured with HLP46 at 50 °C.

The performance curves are measured with external drain. For internal drain the tank pressure has to be added to curve.

8

NG16 - NG32

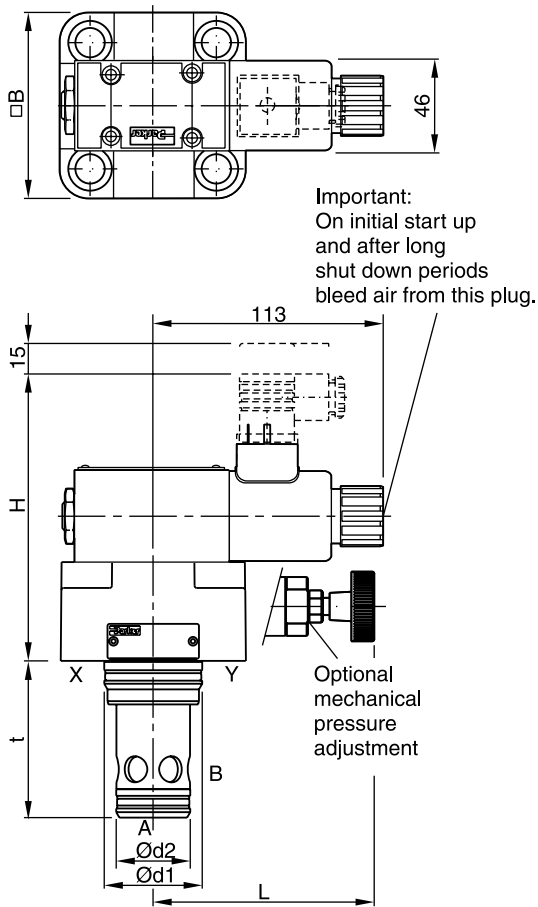

NG40 - NG63 *)

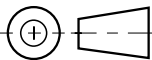
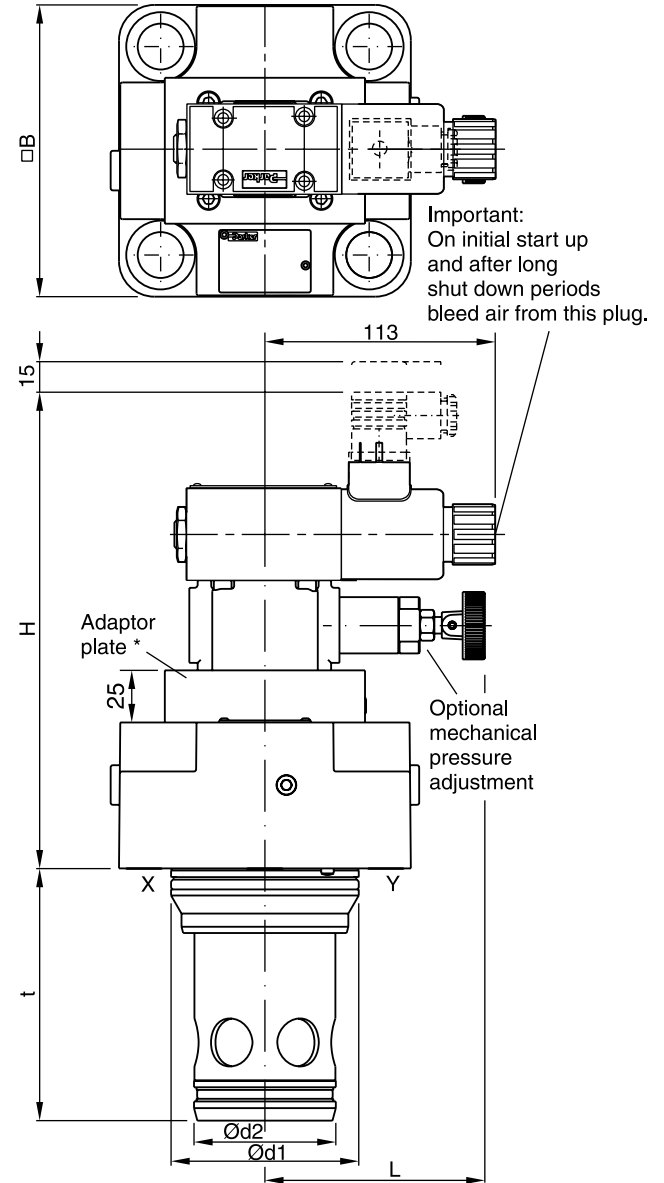

NG	H	B	d ₁	d ₂	t	L
16	135	79 ¹⁾	32	25	56	114
25	140	85	45	34	72	102
32	145	102	60	45	85	95
40	137 (180.2) ²⁾	125	75	55	105	106
50	172 (215.2) ²⁾	140	90	68	122	106
63	187 (230.2) ²⁾	180	120	90	155	106

NG	Kit	ISO 4762-12.9	[Nm]	Kit	
				NBR	FPM
16	BK414	4 x M8x40	31.8	SK-RE16EN	SK-RE16EV
25	BK391	4 x M12x50	108	SK-RE25EN	SK-RE25EV
32	BK415	4 x M16x55	264	SK-RE32EN	SK-RE32EV
40	BK416	4 x M20x70	517	SK-RE40EN	SK-RE40EV
50	BK417	4 x M20x75	517	SK-RE50EN	SK-RE50EV
63	BK418	4 x M30x100	1775	SK-RE63EN	SK-RE63EV

* NG40 without adaptor plate.

¹⁾ Width 65 mm.

²⁾ With mechanical pressure adjustment.