

Pilot operated pressure reducing valves series ZDR are designed for maximum flow rates.

The reducing function can be located in the ports P, A or B. The sizes NG06 and NG10 are equipped with an integral return flow check valve (reducing function in A or B).

Features

- High flow capacity
- Pressure function in P, A or B
- With integral return flow check valve
- Sizes:
ZDR01 - NG06 (CETOP 03)
ZDR02 - NG10 (CETOP 05)



ZDR-P01

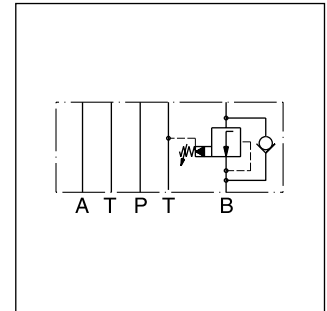

ZDR-B02

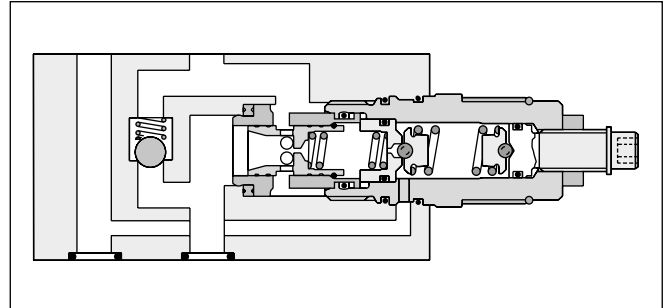

ZDR-B02

Technical data

General			NG06	NG10
Size				
Mounting interface			DIN 24340 A6 ISO 4401 NFPA D03	DIN 24340 A10 ISO 4401 NFPA D05
			CETOP RP 121	
Mounting position			unrestricted	
Ambient temperature		[°C]	-20...+60	
MTTF _D value		[years]	150	
Weight	ZDR-P	[kg]	1.6	2.9
	ZDR-AR / BR	[kg]	1.8	3.0
Hydraulic				
Max. operating pressure		[bar]	350 (ZDR-AR / BR 315)	315
Nominal flow		[l/min]	80	120
Pilot oil		[l/min]	0.3	0.3
Fluid			Hydraulic oil according to DIN 51524	
Fluid temperature		[°C]	-20...+70 (NBR: -25...+70)	
Viscosity	permitted	[cSt] / [mm ² /s]	20 ... 400	
	recommended	[cSt] / [mm ² /s]	30 ... 80	
Filtration			ISO 4406 (1999); 18/16/13	

Ordering code

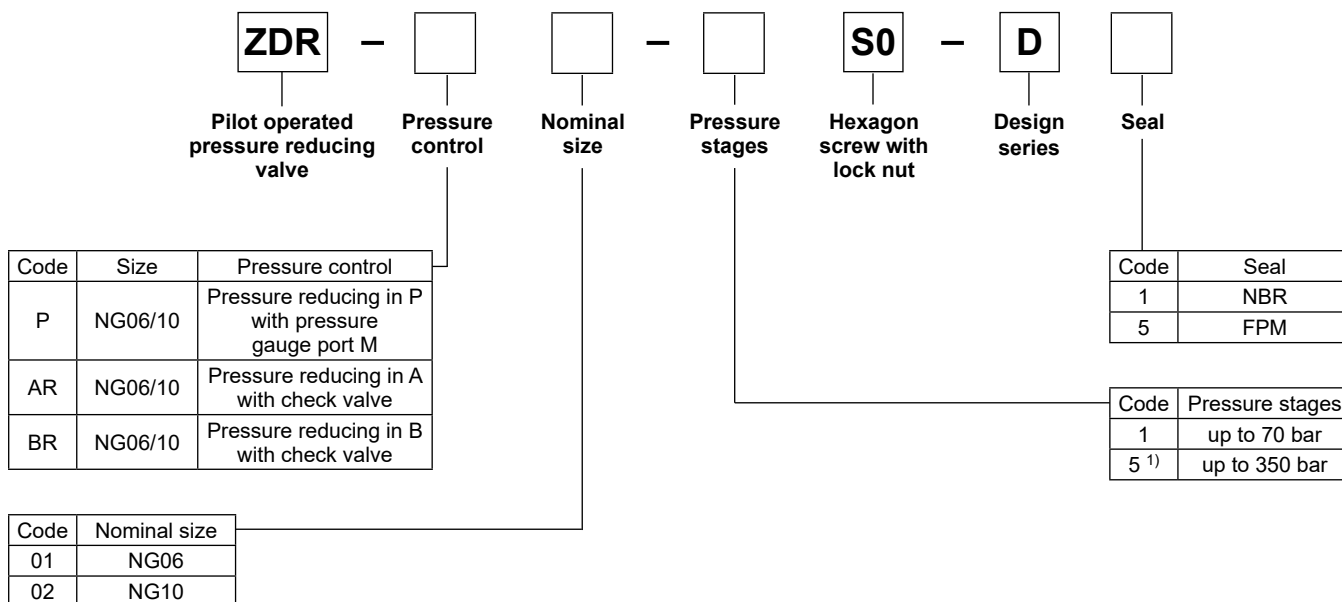

**7 Ordering Code Details
 ZDR01**

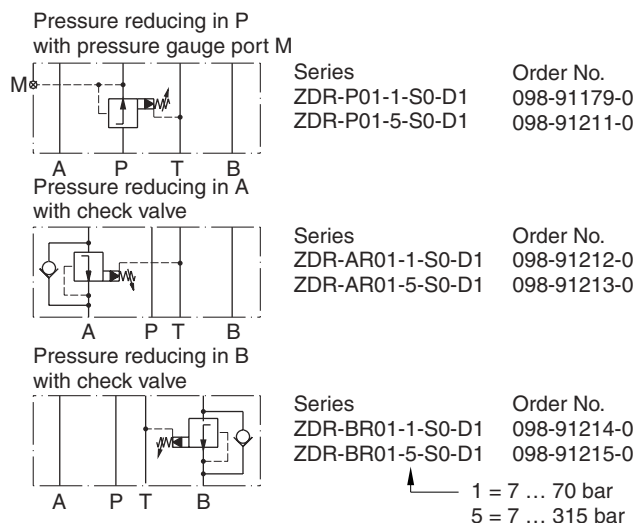

ZDR02

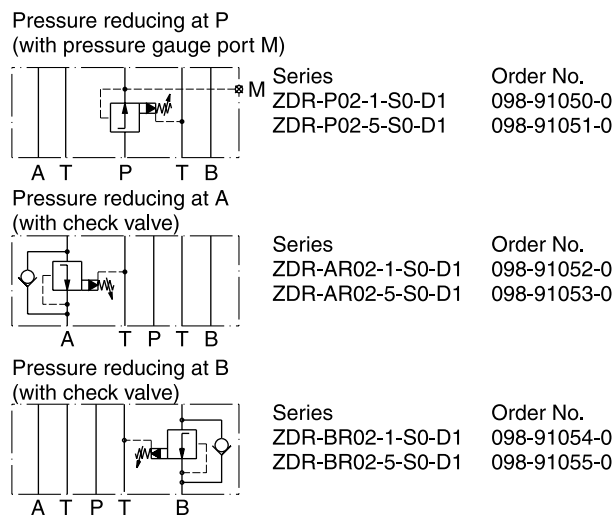

¹⁾ Code AR, BR and size 10 up to 315 bar.

p/Q performance curves
ZDR-P/AR/BR01

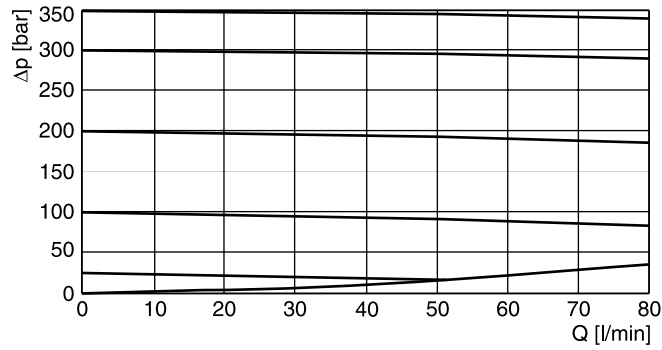

ZDR-P/AR/BR02

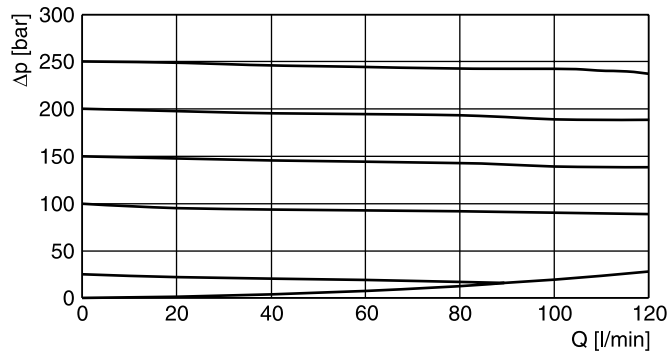

All characteristic curves measured with HLP46 at 50°C.

7

ZDR01

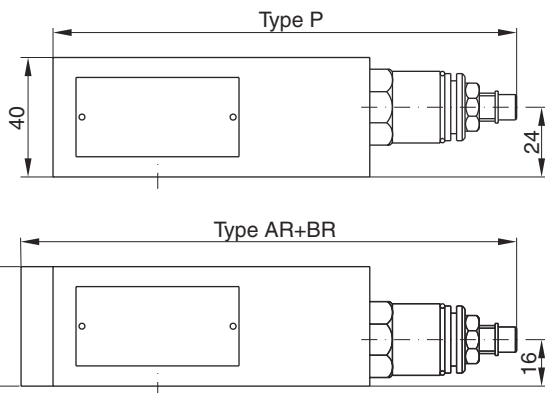
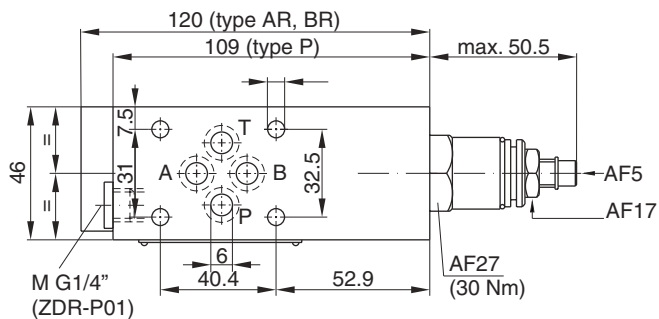

Seal kit	
Seal	Order code
1	098-91184-0
5	098-91185-0
Complete cartridge	
Pressure stage	Order code
1	098-91102-0
5	098-91103-0

7

ZDR02

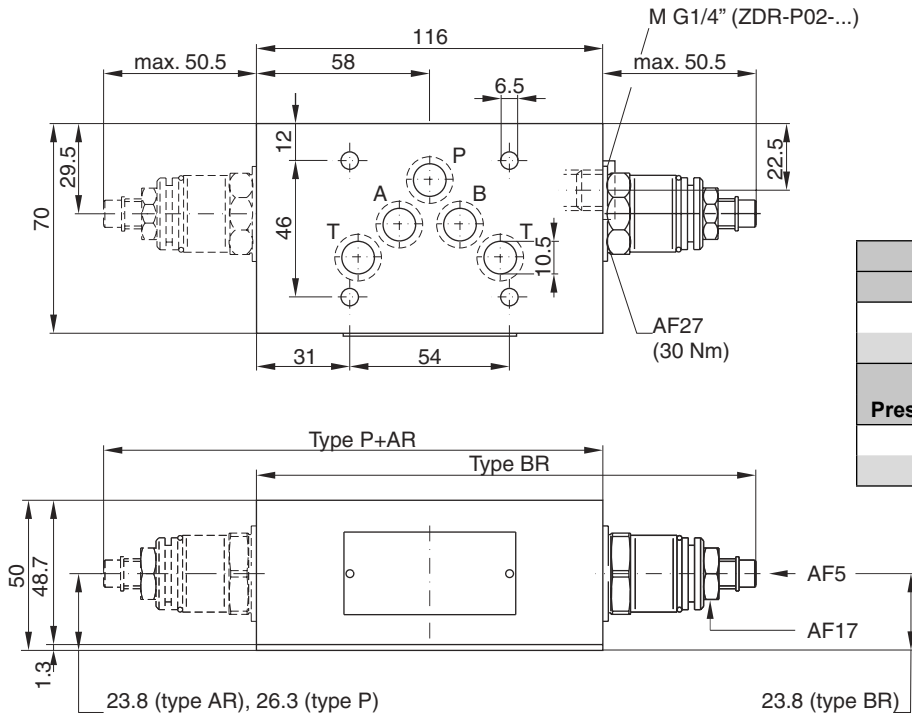

Seal kit	
Seal	Order code
1	098-91082-0
5	098-91083-0
Complete cartridge	
Pressure stage	Order code
1	098-91102-0
5	098-91103-0

