

Characteristics

The series of pilot operated control valves D30FP closes the gap between the direct operated D3FP valves and the conventional pilot operated D31FP valves.

Providing high flow capacity and practically no flow limits like D31FP in the envelope size of the D3FP.

The valve works with the hydraulic follower principle, with a moving sleeve as main spool.

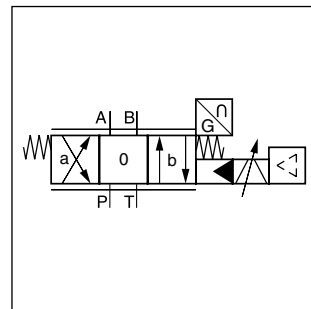

3

Features

- Pilot operated with hydraulic follower sleeve
- No flow limit up to 350 bar through the valve
- Defined spool positioning at power-down - optional P-A / B-T or P-B / A-T or center position (for overlapped spools)

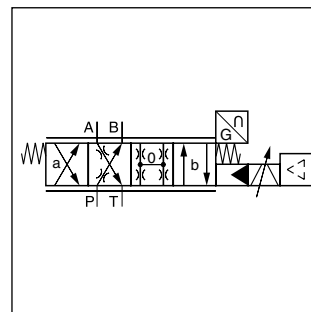
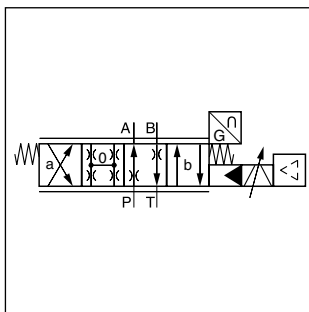

D30FP*3

with hydraulic follower principle

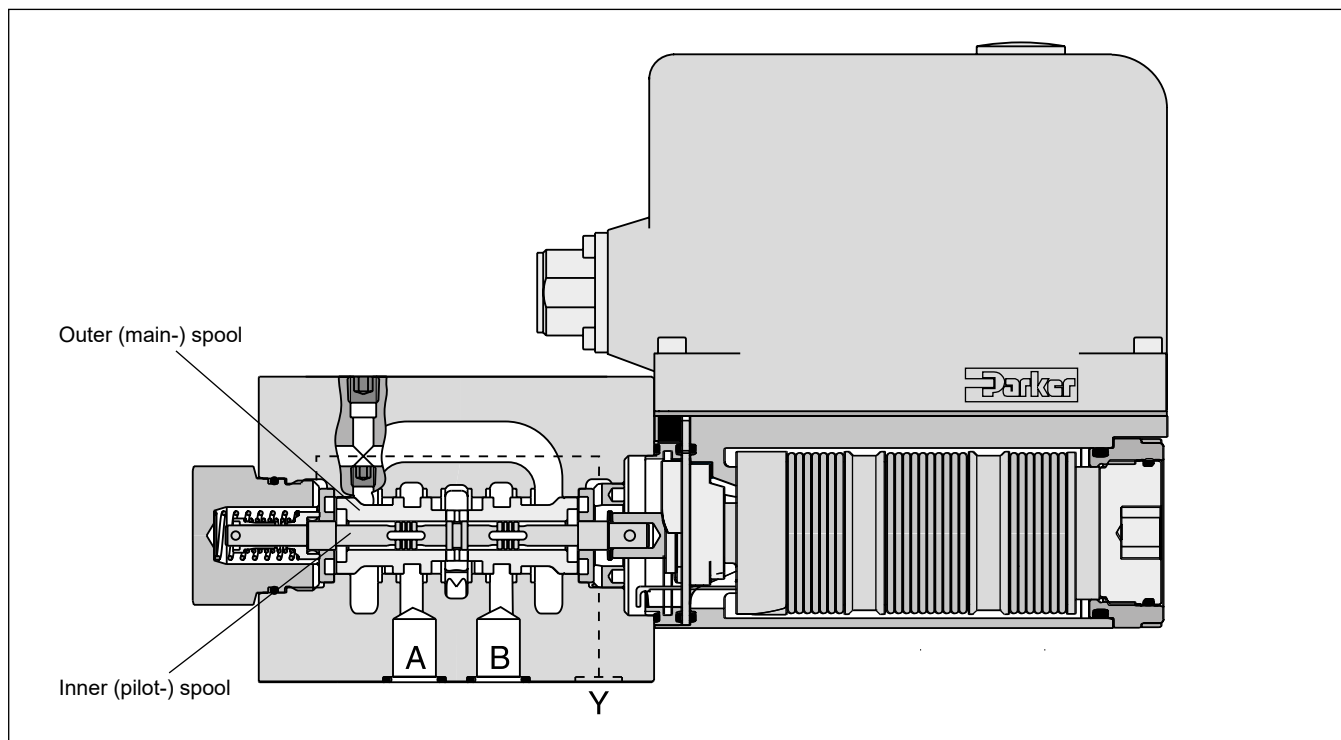

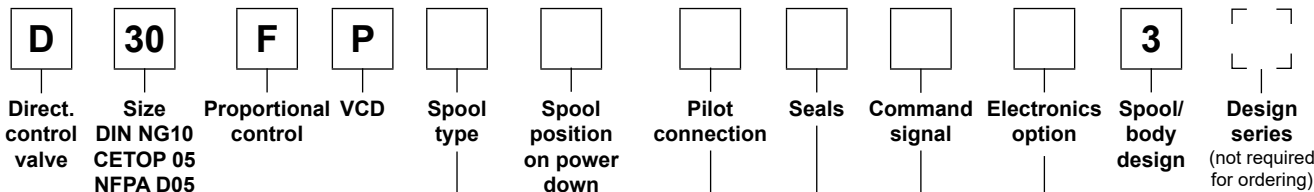

Code	Spool type	Flow [l/min] at Δp 5 bar per metering edge
Zerolap		
E50U		80
B60U		80 / 40
Overlap		
E01U		80
E02U		80
B31U		80 / 40
B32U		80 / 40

Code	Connection type
0	6 + PE acc. EN175201-804
5	11 + PE acc. EN175201-804
7	6 + PE + Enable

Code	Signal	Function
B	+/- 10 V	0...+10 V -> P-A
E	+/- 20 mA	0...+20 mA -> P-A
S	4...20 mA	12...20 mA -> P-A

Code	Seals
N	NBR
V	FPM
H	for HFC fluid

Code	Spool pos. at power down
A ¹⁾	
B ¹⁾	
C ²⁾	

Code	Inlet	Drain
1 ³⁾	internal	external
4	internal	internal

3

Short delivery time
for all variations

Please order connector separately, see chapter 3 accessories.
 Parametrizing cable OBE -> RS232, item no. 40982923

1) Approx. 10 % opening, only zerolapped spools.
 2) Only for overlapped spools.
 3) For tank pressure >35 bar.

General			
Design			Pilot operated servo proportional DC valve
Actuation			VCD® actuator
Size			NG10 / CETOP 05 / NFPA D05
Mounting interface			DIN 24340 / ISO 4401 / CETOP RP121 / NFPA
Mounting position			horizontal mounting preferred (other mounting positions after consultation)
Ambient temperature	[°C]		-20...+50
MTTF _D value ¹⁾	[years]		75
Weight	[kg]		6.5
Vibration resistance	[g]		10 Sinus 5...2000 Hz acc. IEC 68-2-6 10 (RMS) Random noise 20...2000 Hz acc. IEC 68-2-36 15 Shock acc. IEC 68-2-27
Hydraulic			
Max. operating pressure	[bar]		Ports P, A, B 350; Port T 35 for internal drain, 250 for external drain Port Y 35 ²⁾
Fluid			Hydraulic oil according to DIN 51524 ... 535, other on request
Fluid temperature	[°C]		-20...+60 (NBR: -25...+60)
Viscosity permitted	[cSt]/[mm ² /s]		20...400
Viscosity recommended	[cSt]/[mm ² /s]		30...80
Filtration			ISO 4406; 18/16/13
Flow nominal at Δp=5 bar per control edge ³⁾	[l/min]		80
Flow maximum	[l/min]		250
Leakage at 100 bar	[ml/min]		<1800 (Zerolap spool); <1000 (Overlap spool)
Opening point	[%]		set to 9 commande signal (see flow characteristics)
Pilot supply pressure	[bar]		>5 higher than tank pressure (only internal pilot oil supply)
Static / Dynamic			
Step response at 100 % step ⁴⁾	[ms]		<7
Frequency response (±5 % signal) ⁴⁾	[Hz]		120 (amplitude ratio -3 dB), 120 (phase lag -90°)
Hysteresis	[%]		<0.05
Sensitivity	[%]		<0.03
Temperature drift	[%/K]		<0.025
Electrical characteristics			
Duty ratio	[%]		100
Protection class			IP65 in accordance with EN 60529 (with correctly mounted plug-in connector)
Supply voltage/ripple	[V]		DC 22 ... 30, electric shut-off at < 19, ripple < 5 % eff., surge free
Current consumption max.	[A]		3.5
Pre-fusing	[A]		4.0 medium lag
Input signal			
Code B	Voltage	[V]	10...0...-10, ripple <0.01 % eff., surge free, 0...+10 V P->A
	Impedance	[kOhm]	100
Code E	Current	[mA]	20...0...-20, ripple <0.01 % eff., surge free, 0...+20 mA P->A
	Impedance	[Ohm]	<250
Code S	Current	[mA]	4...12...20, ripple <0.01 % eff., surge free, 12...20 mA P->A <3.6 mA = disable, >3.8 mA = according to NAMUR NE43
	Impedance	[Ohm]	<250
Differential input max.			
Code 0	[V]		30 for terminal D and E against PE (terminal G)
Code 5	[V]		30 for terminal 4 and 5 against PE (terminal ⊥)
Code 7	[V]		30 for terminal D and E against PE (terminal G)
Enable signal (only code 5/7)	[V]		5...30, R _i = > 8 kOhm
Diagnostic signal	[V]		+10...0...-10 / +12.5 error detection, rated max. 5 mA
EMC			EN 61000-6-2, EN 61000-6-4
Electrical connection	Code 0/7		6 + PE acc. EN 175201-804
	Code 5		11 + PE acc. EN 175201-804
Wiring min.	Code 0/7	[mm ²]	7 x 1.0 (AWG 18) overall braid shield
	Code 5	[mm ²]	8 x 1.0 (AWG 18) overall braid shield
Wiring length max.		[m]	50

¹⁾ If valves with onboard electronics are used in safety-related parts of control systems, in case the safety function is requested, the valve electronics voltage supply is to be switched off by a suitable switching element with sufficient reliability.

²⁾ For applications with p_r>35 bar (max. 250 bar) the Y-port has to be connected and the plug in the Y-port has to be removed.

³⁾ Flow rate for different Δp per control edge: $Q_x = Q_{Nom.} \cdot \sqrt{\frac{\Delta p_x}{\Delta p_{Nom.}}}$

⁴⁾ Measured with load (100 bar pressure drop/two control edges).

Flow curves

(Overlapped spool set to opening point 9 %)
 at $\Delta p = 5$ bar per metering edge
 Spool type **E01/02, E50**

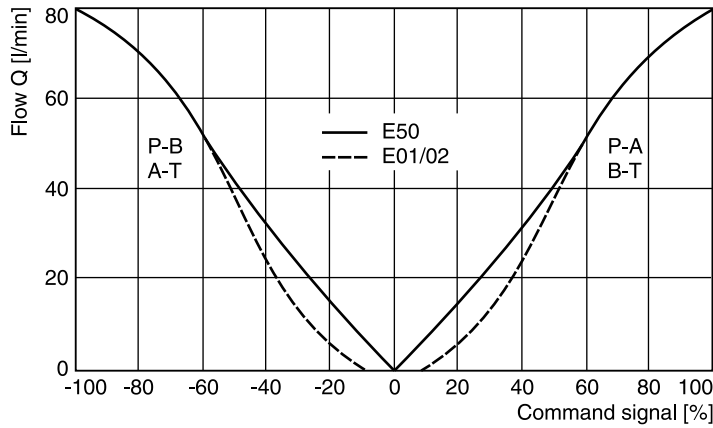

Pressure gain

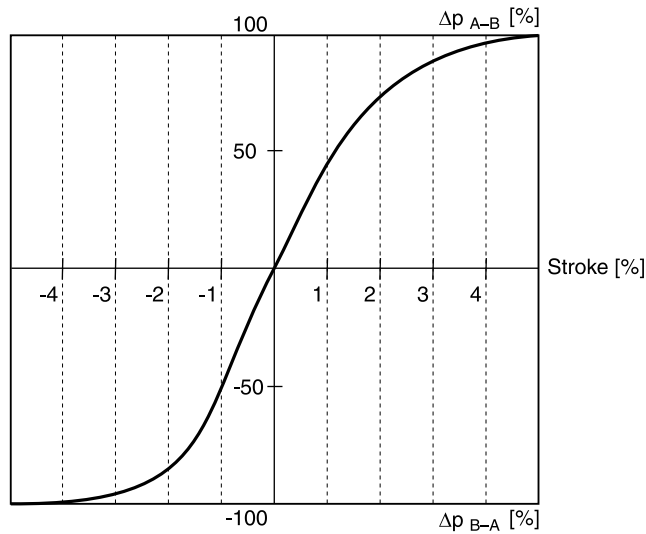

Frequency response

± 5 % command signal
 ± 25 % command signal

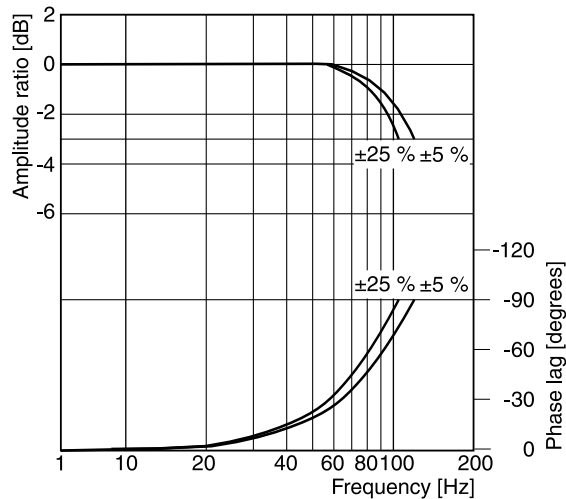

3

Code 0

Parametrizing cable
 3 m length
 Item no.: 40982923

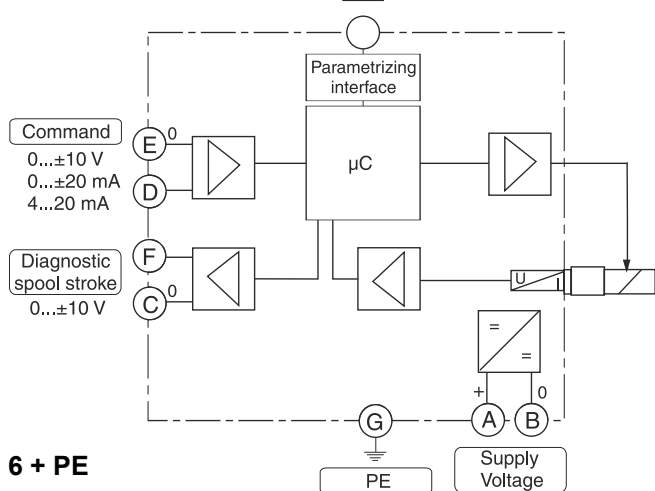

6 + PE

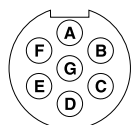

Code 5

Parametrizing cable
 3 m length
 Item no.: 40982923

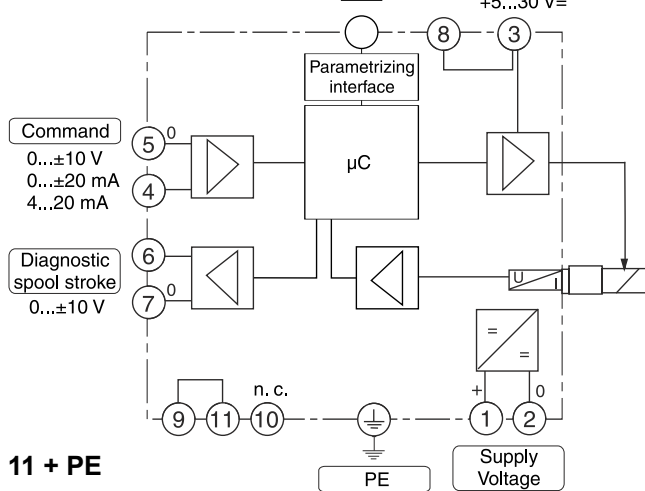

11 + PE

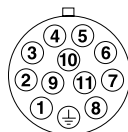

Code 7

Parametrizing cable
 3 m length
 Item no.: 40982923

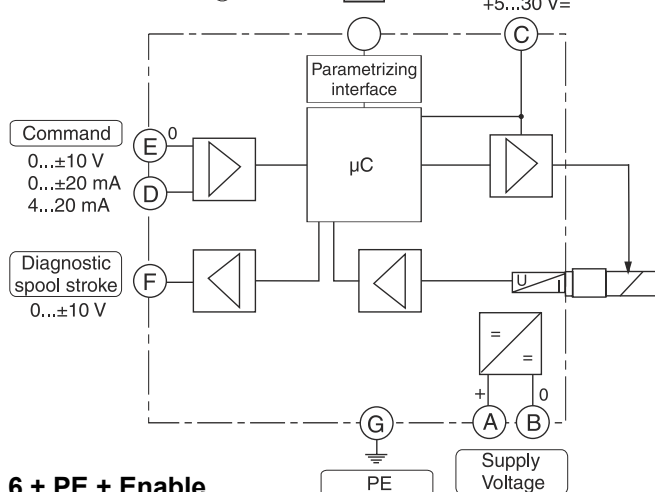

6 + PE + Enable

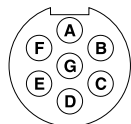

1) Do not connect with supply voltage zero.

ProPxD interface program

The ProPxD software allows quick and easy setting of the digital valve electronics. Individual parameters as well as complete settings can be viewed, changed and saved via the comfortable user interface. Parameter sets saved in the non-volatile memory can be loaded to other valves of the same type or printed out for documentation purposes.

The PC software can be downloaded free of charge at www.parker.com/isde – see page “Support” or directly at www.parker.com/propxd.

Features

- Comfortable editing of valve parameters
- Saving and loading of customized parameter sets
- Executable with all Windows® operating systems from Windows® XP upwards
- Simple communication between PC and valve electronics via serial interface RS232C

The valve electronics cannot be connected to a PC with a standard USB cable – this can result in damages of PC and/or valve electronics.

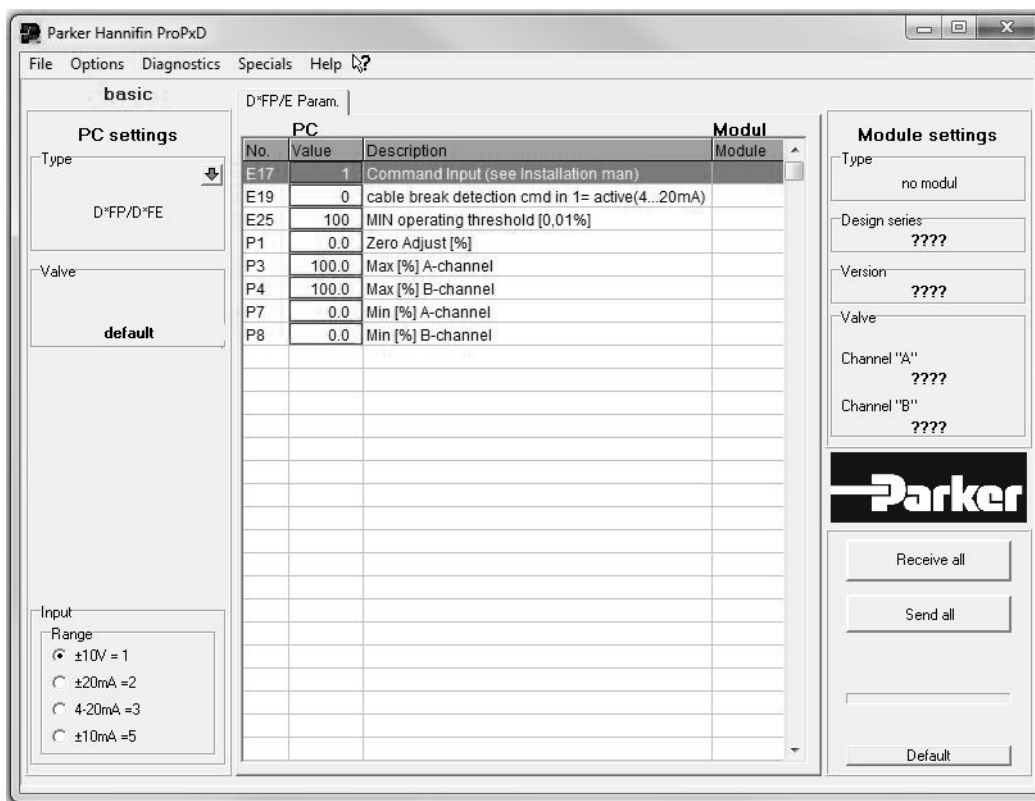

The parametrizing cable may be ordered under item no. 40982923.

3

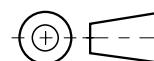
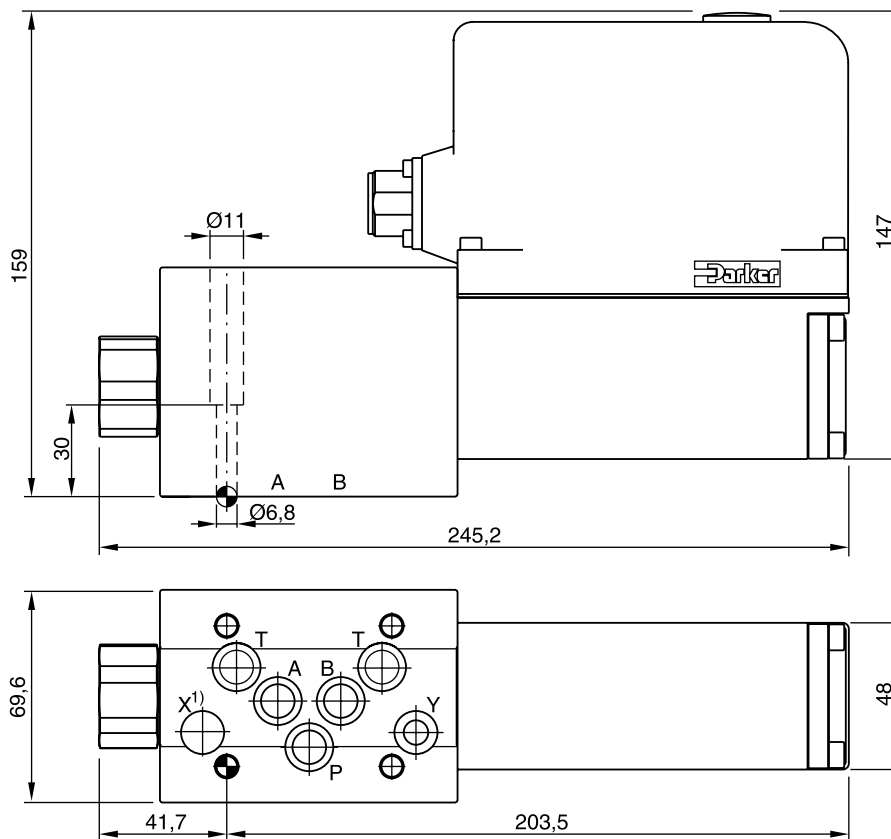

3

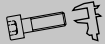

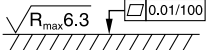
Surface finish	 Kit	 4xM6x40 ISO 4762-12.9	 13.2 Nm ±15 %	 Kit
	BK385			NBR: SK-D3FP FPM: SK-D3FP-V HFC: SK-D3FP-H

¹⁾ O-ring recess diameter on valve body.