

The proportional pressure reducing valves series D1FV are available with and without onboard electronics (OBE).

**D1FV OBE**

The digital onboard electronics is situated in a robust metal housing, which allows the usage under rough environmental conditions.

The nominal values are factory set. The cable for connection to a serial RS232 interface is available as accessory.

**D1FV for external electronics**

The parameters can be saved, changed and duplicated in combination with the digital power amplifier PWD00A-400. The value parameters can be edited with the common ProPxD software for both versions.

The D1FV valves control the pressure in the A- or B-ports using the barometric feedback principle.

Valves with explosion proof solenoids Ex e mb II see catalogue HY11-3343.

Download: [www.parker.com/euro\\_hcd](http://www.parker.com/euro_hcd) - see "Literature"

**Technical Features**

- Barometric feedback
- 3 command options for D1FV OBE:  $\pm 10$  V, 4...20 mA,  $\pm 20$  mA
- High repeatability from valve to valve
- Low hysteresis
- Manual override
- Pressure stages 25 bar and 45 bar



D1FV



D1FV OBE

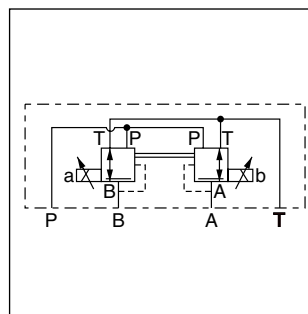

Function C

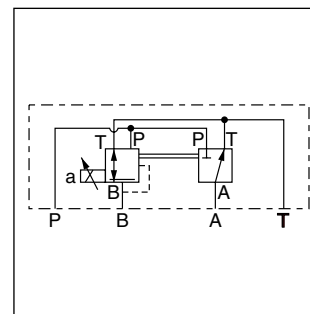

Function E

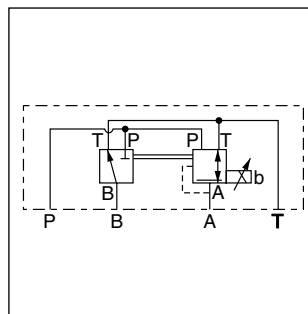

Function K

**D1FV\*3 OBE**

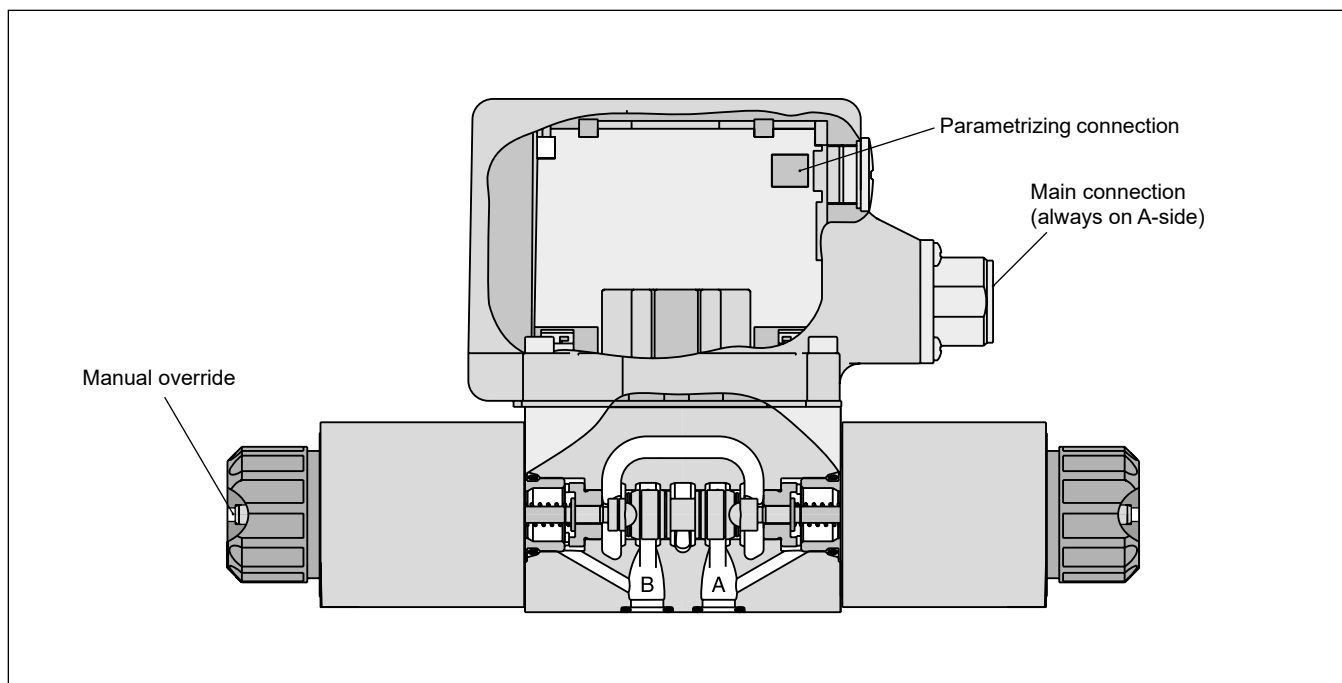

**D1FV**

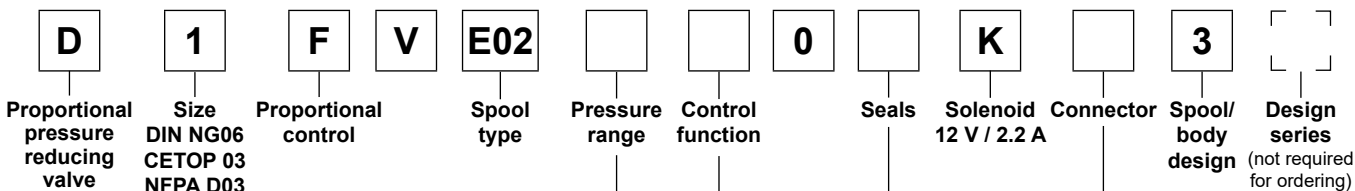

Code	Pressure range
C	25 bar
D	45 bar

Code	Connector
W	Connector as per EN 175301-803
J	Connector DT04-2P "Deutsch"

Code	Control function
C	
E	
K	

Code	Seals
N	NBR
V	FPM

**D1FV OBE (with onboard electronics)**

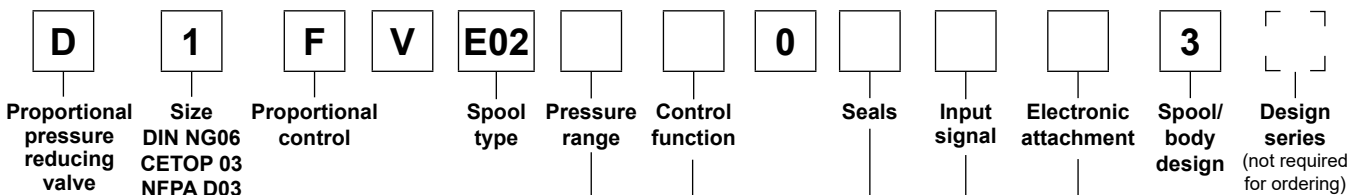

Code	Pressure range
C	25 bar
D	45 bar

Code	Control function
C	
E	
K	

Spool position				
Code	Input signal <sup>1)</sup>	Function	Port	Options
F0	0...+/-10 V	0...+10 V > P-A	6 + PE	Potentiometer supply
G0	0...+/-20 mA	0...+20 mA > P-A	6 + PE	—
M0	0...+/-10 V	0...+10 V > P-B	6 + PE	Potentiometer supply
S0	4...20 mA	12...20 mA > P-A	6 + PE	—
W5 <sup>2)</sup>	0...+/-10 V	0...+10 V > P-A	11 + PE	Command channel & potentiometer supply
	4...20 mA	12...20 mA > P-A		
	0...+/-20 mA	0...+20 mA > P-A		

Code	Seals
N	NBR
V	FPM

Short delivery time  
 for all variations

Please order connector separately, see chapter 3 accessories.  
 Parametrizing cable OBE® RS232, item no. 40982923

<sup>1)</sup> Single solenoid always 0...+10 V respectively 4...20 mA.  
<sup>2)</sup> Factory set ±10 V on delivery.

<b>General</b>		
Design		Direct operated proportional pressure reducing valve
Actuation		Proportional solenoid
Size		NG06/CETOP 03/NFPA D03
Mounting interface		DIN 24340 / ISO 4401 / CETOP RP121 / NFPA
Mounting position		unrestricted
Ambient temperature	[°C]	-20...+60
MTTF <sub>D</sub> value <sup>1)</sup>	[years]	150
Weight (OBE)	[kg]	2.2 (2.9)
<b>Hydraulic</b>		
Max. operating pressure	[bar]	Ports P, A, B 350; Port T 185
Max. pressure drop PABT / PBAT	[bar]	350
Fluid		Hydraulic oil according to DIN 51524...535, other on request
Fluid temperature	[°C]	-20...+60 (NBR: -25...+60)
Viscosity permitted	[cSt] / [mm <sup>2</sup> /s]	20...400
Viscosity recommended	[cSt] / [mm <sup>2</sup> /s]	30...80
Filtration		ISO 4406; 18/16/13
Max. flow	[l/min]	10
Min. primary pressure	[bar]	30 at 25 pressure range, 50 at 45 pressure range
<b>Static / Dynamic</b>		
Hysteresis	[%]	<4
Temperature drift solenoid current	[%/K]	<0.02
<b>Electrical characteristics (D1FV)</b>		
Duty ratio	[%]	100 ED; CAUTION: coil temperature up to 150 °C possible
Protection class		Standard (as per EN175301-803) IP65 in accordance with EN60529 (with correctly mounted plug-in connector); DT04-2P "Deutsch" IP69K (with correctly mounted plug-in connector)
Supply voltage	[V]	12
Current consumption	[A]	2.2
Resistance	[Ohm]	4.4
Solenoid connection		Connector as per EN 175301-803 (code W), DT04-2P "Deutsch" connector (code J). Solenoid identification as per ISO 9461.
Wiring min.	[mm <sup>2</sup> ]	3x1.5 (AWG 16) overall braid shield (code W), "Deutsch" connector DP4 2 Pin (code J)
Wiring length max.	[m]	50 recommended

<sup>1)</sup> If valves with onboard electronics are used in safety-related parts of control systems, in case the safety function is requested, the valve electronics voltage supply is to be switched off by a suitable switching element with sufficient reliability.

With electrical connections the protective conductor (PE  $\perp$ ) must be connected according to the relevant regulations.

Technical Data / Characteristic Curves

3

Electrical characteristics (D1FV OBE)		
Vibration resistance	[g]	10 Sinus 5...2000 Hz acc. IEC 68-2-6 10 (RMS) Random noise 20...2000 Hz acc. IEC 68-2-36 15 Shock acc. IEC 68-2-27
Duty ratio	[%]	100 ED; CAUTION: coil temperature up to 150 °C possible
Protection class		IP65 in accordance with EN 60529 (plugged and mounted)
Supply voltage/ripple DC	[V]	18...30, ripple < 5 % eff., surge free
Current consumption max.	[A]	2.0
Pre fusing medium lag	[A]	2.5
Input signal		
Codes F0 & W5 voltage	[V]	+10...0...-10, ripple < 0.01 % eff., surge free, Ri = 100 kOhm, 0...+10 V → P -> A
Codes M0 voltage	[V]	+10...0...-10, ripple < 0.01 % eff., surge free, Ri = 100 kOhm, 0...+10 V → P -> B
Codes S0 & W5 current	[mA]	4...12...20, ripple < 0.01 % eff., surge free, Ri = <250 Ohm, 12...20 mA → P -> A < 3.6 mA = enable off, > 3.8 mA = enable on (acc. to NAMUR NE43)
Code G0	[mA]	+20...0...-20, ripple < 0.01 % eff., surge free, Ri = <250 Ohm, 0...+20 mA → P -> A
Differential input max.		
Codes F0, G0, M0 & S0	[V]	30 for terminal D and E against PE (terminal G) 11 for terminal D and E against 0V (terminal B)
Code W5	[V]	30 for terminal 4 and 5 against PE (terminal PE) 11 for terminal 4 and 5 against 0V (terminal 2)
Channel recall signal	[V]	0...2.5: off / 5...30: on / Ri = 100 kOhm
Adjustment ranges		
Min	[%]	0...50
Max	[%]	50...100
Ramp	[s]	0...32.5
Interface		RS 232, parametrizing connection 5pole
EMC		EN 61000-6-2, EN 61000-6-4
Central connection		
Codes F0, G0, M0 & S0		6 + PE acc. to EN 175201-804
Code W5		11 + PE acc. to EN 175201-804
Wiring min.		
Codes F0, G0, M0 & S0	[mm <sup>2</sup> ]	7 x 1.0 (AWG16) overall braid shield
Code W5	[mm <sup>2</sup> ]	11 x 1.0 (AWG16) overall braid shield
Wiring length max.		50

Flow characteristics

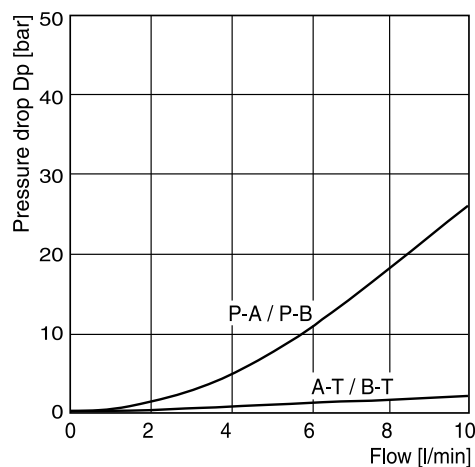

All characteristic curves measured with HLP46 at 50 °C.

Code F0, M0  
 6 + PE acc. to EN 175201-804

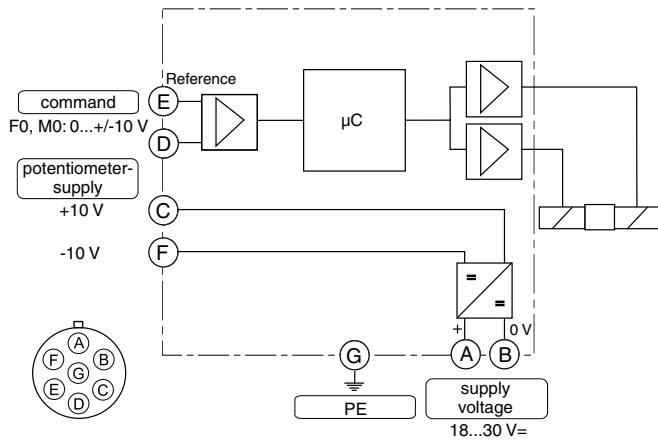

Code G0, S0  
 6 + PE acc. to EN 175201-804

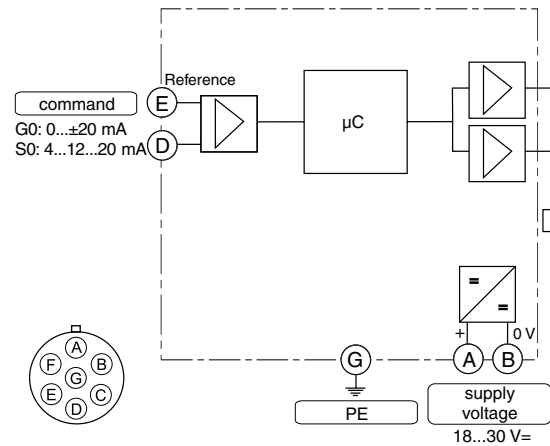

**3**

Code W5  
 11 + PE acc. to EN 175201-804

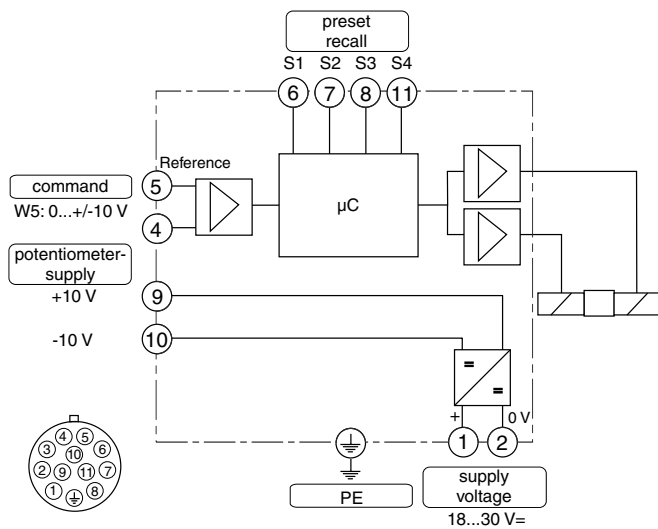

**ProPxD interface program**

The ProPxD software permits comfortable parameter setting for the module electronics. Via the clearly arranged entry mask the parameters can be noticed and modified. Storage of complete parameter sets is possible as well as printout or record as a text file for further documentation. Stored parameter sets may be loaded anytime and transmitted to other valves. Inside the electronics a non-volatile memory stores the data with the option for recal-ling or modification.

The PC software can be downloaded free of charge at [www.parker.com/isde](http://www.parker.com/isde) – see page "Support" or directly at [www.parker.com/propxd](http://www.parker.com/propxd).

**Features**

- Comfortable editing of all parameters
- Depiction and documentation of parameter sets
- Storage and loading of optimized parameter adjust-ments
- Executable with all actual Windows® operating systems from Windows® XP upwards
- Plain communication between PC and electronics via serial interface RS232C

**The parametrizing cable may be ordered under item no. 40982923.**

**3**

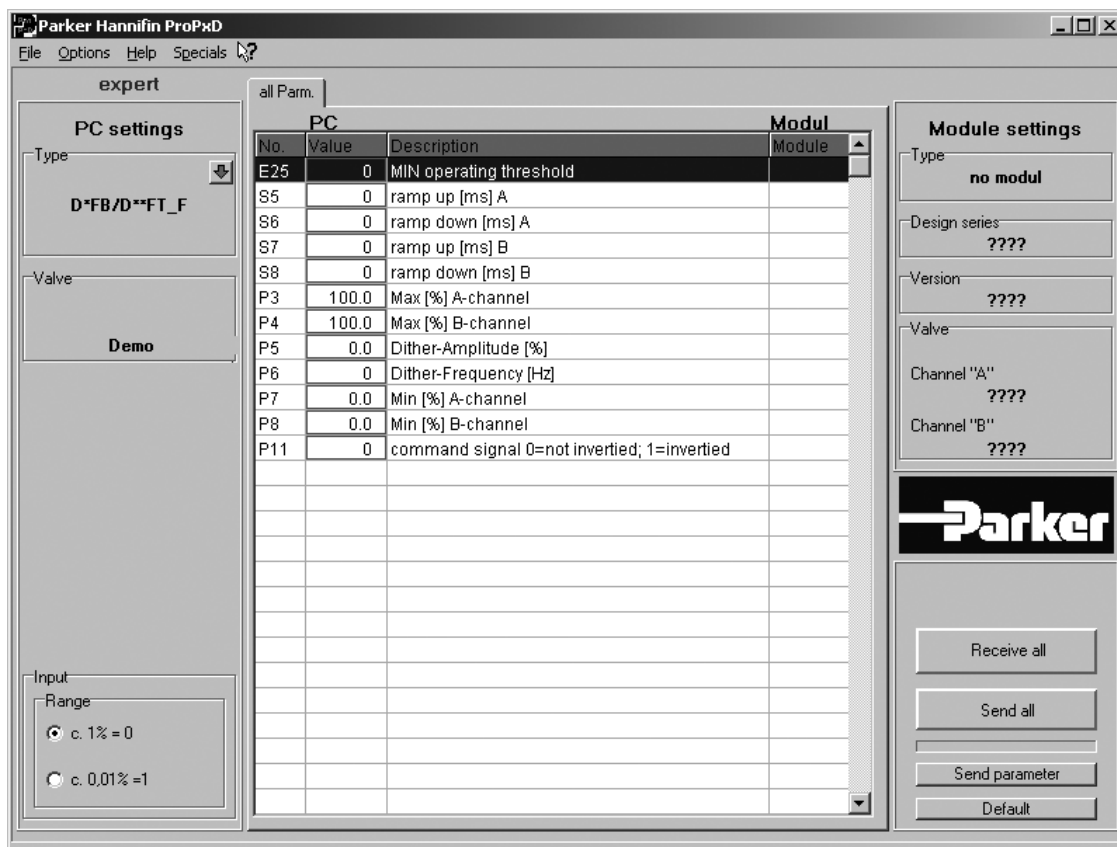

**D1FV\*C**

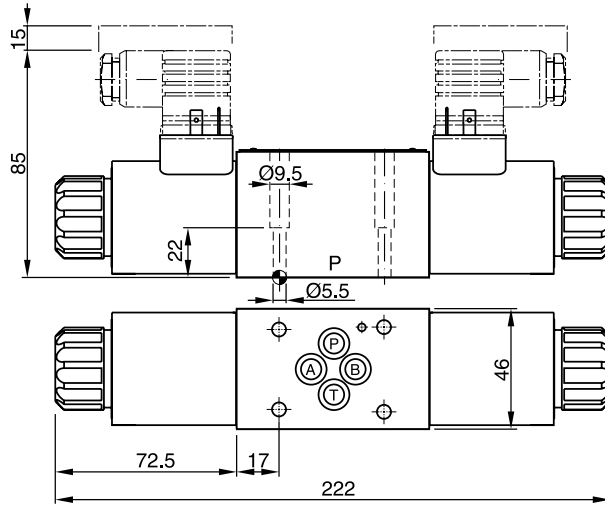

**D1FV\*E**

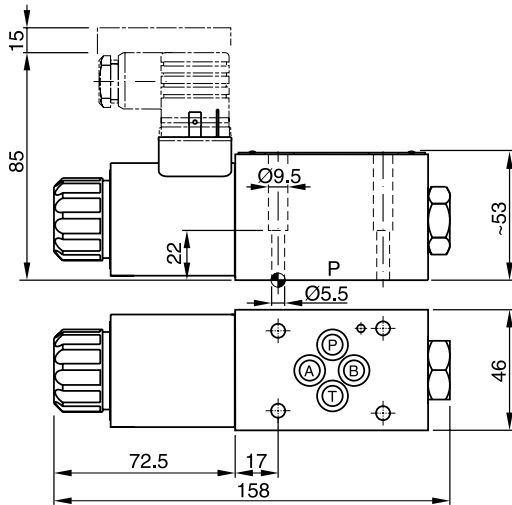



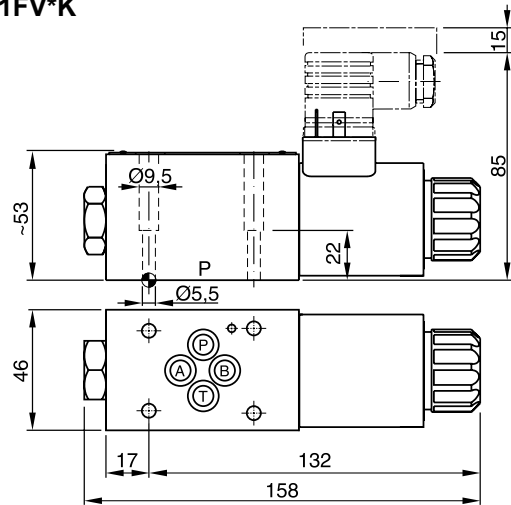

**D1FV\*K**

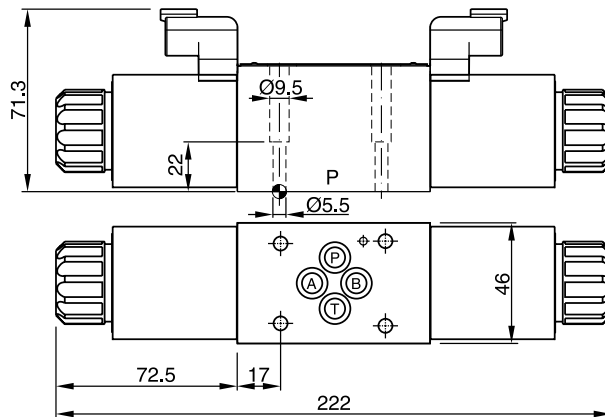

**D1FV\*C with DT04-2P "Deutsch" connector  
 (only C style shown)**

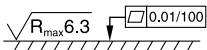

Surface finish	 Kit	 Kit	 Kit	 Kit NBR
	BK375	4x M5x30 ISO 4762-12.9	7.6 Nm ±15 %	SK-D1FB

**D1FV\*C OBE**

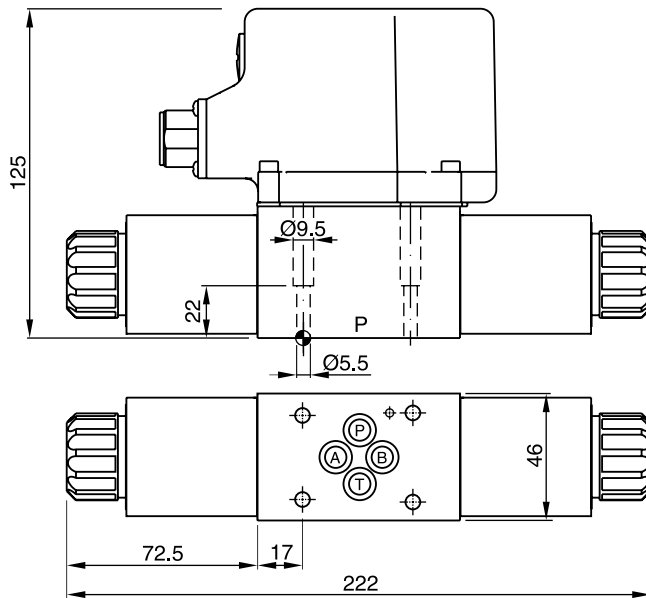



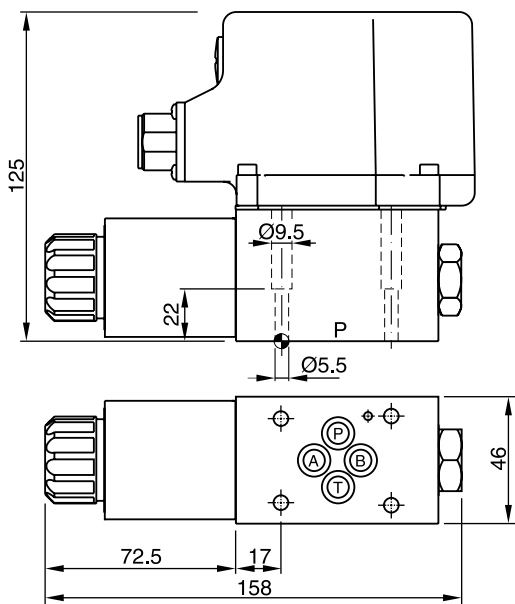

**D1FV\*E OBE**

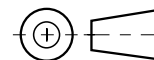
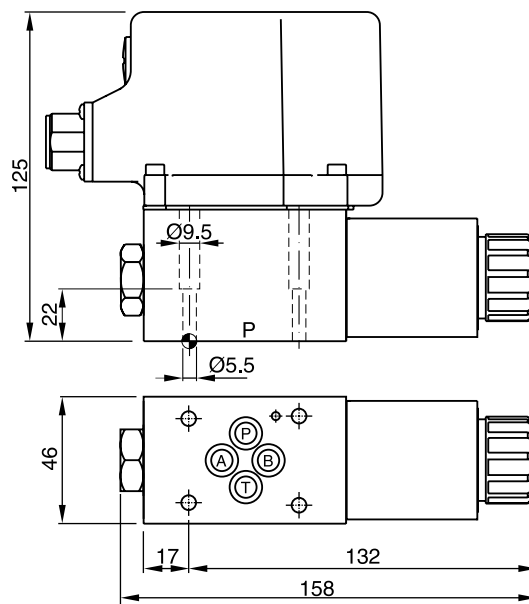

**D1FV\*K OBE**

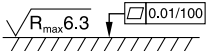

Surface finish	 Kit	 Kit	 Kit	 Kit NBR
	BK375	4x M5x30 ISO 4762-12.9	7.6 Nm ±15 %	SK-D1FB