

**Characteristics**

**Introduction**

DFplus valves with EtherCAT interface fulfill the requirements of modern communication between valve and main control. Due to high data transmission speed and short cycle times, the high dynamics of the DFplus valves can be also utilized within the fieldbus system.

The valve is actuated and monitored by the EtherCAT interface. Actual value (spool position), temperature, operating hours and different error messages are available as diagnostic signals. The valve parameters are factory set and can be adapted with the Parker ProPxD software via the parametrizing interface.

In addition to the fieldbus communication, the valves provide the range of functions of the standard version including analogue command signal and diagnostic spare stroke. Thus they can be operated independent of the fieldbus control, particularly during commissioning and maintenance.

The option with EtherCAT is available for the series:

- D1FP, D3FP
- D30FP
- D31FP, D41FP, D81FP, D91FP, D111FP

as well as for cartridge valves TDP, TEP and TPQ in chapter 8.



D1FP with EtherCAT



**Features EtherCAT interface**

- EtherCAT interface, 2x M12x1, connector 4-Pin (EtherCAT In and EtherCAT Out)
- High dynamics
- High flow capacity
- Onboard electronics

**Technical Data**

Electrical			
Duty ratio		[%]	100
Protection class	IP65 in accordance with EN 60529 (with correctly mounted plug-in connector)		
Supply voltage/ripple		[V]	22 ... 30, electric shut-off at < 19, ripple < 5 % eff., surge free
Current consumption max.		[A]	3.5
Pre fusing		[A]	4.0 medium lag
Differential input		[V]	30 for terminal D and E against PE (terminal G)
Diagnostic signal		[V]	+10...0...-10 / +12.5 error detection, rated max. 5 mA
EMC	EN 61000-6-2, EN 61000-6-4		
Electrical connection	6 + PE acc. to EN 175201-804		
EtherCAT interface	2 x socket M12x1: 5p acc. to IEC61076-2-101		
Wiring min.		[mm <sup>2</sup> ]	3 x 1.0 (AWG16) overall braid shield
Wiring length max.		[m]	50
Wiring EtherCAT	acc. to CiA DS-301 Version 4 / Twisted pair cable acc. to ISO11898		
EtherCAT profiles	Communication Layer IEC 61158-x-12, 301 Version 4 Device Profile in accordance with CiA DS - 408 Version 1.5.2 CANopen over EtherCAT (object dictionary)		
Functionality	One PDO (Receive) One PDO (Transmit) BUS-cycle time down to 0.250 mSec.		
Parameterization			
Interface	RS 232, parametrizing cable order code 40982923		
Interface program	ProPxD (see www.parker.com/propxd)		
Adjustment ranges	Min	[%]	0...50
	Max	[%]	50...100
	Ramp	[%]	0...32.5

The EtherCAT option is also available for the cartridge valves in chapter 8, series TDP, TEP and TPQ

**Direct operated proportional DC valve**

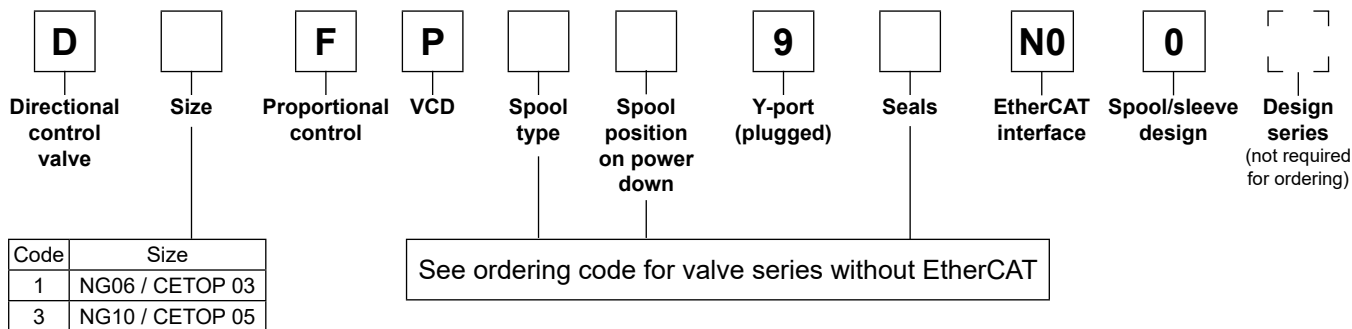

**Pilot operated proportional DC valve**

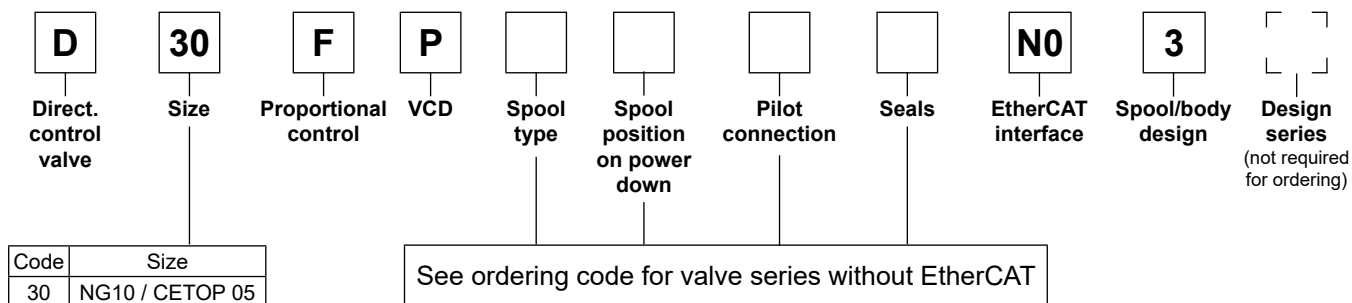

**Pilot operated proportional DC valve**

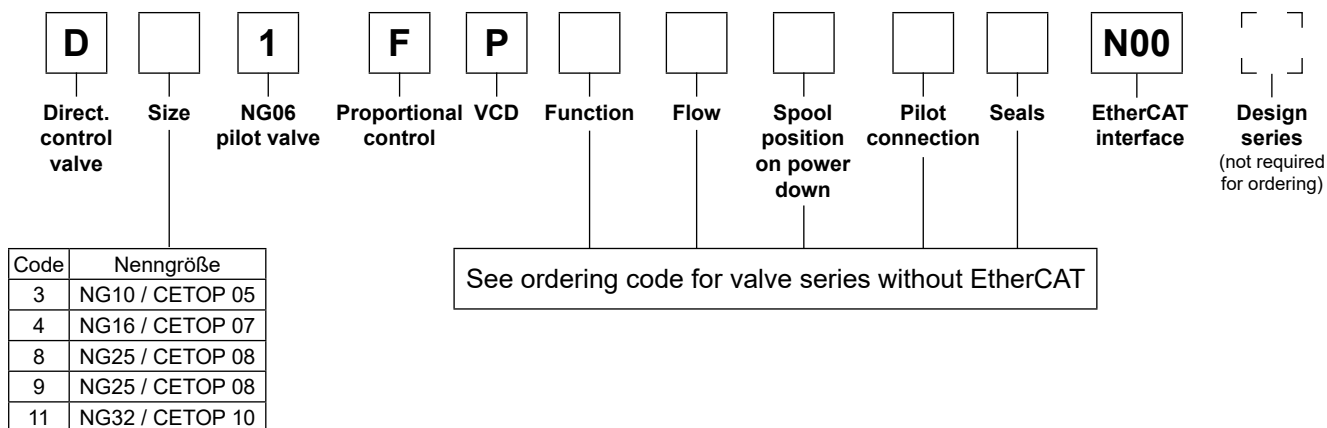

Please order connector separately, see chapter 3 accessories.  
 Parametrizing cable OBE ® RS232, item no. 40982923

**Block diagram**  
**EtherCAT**

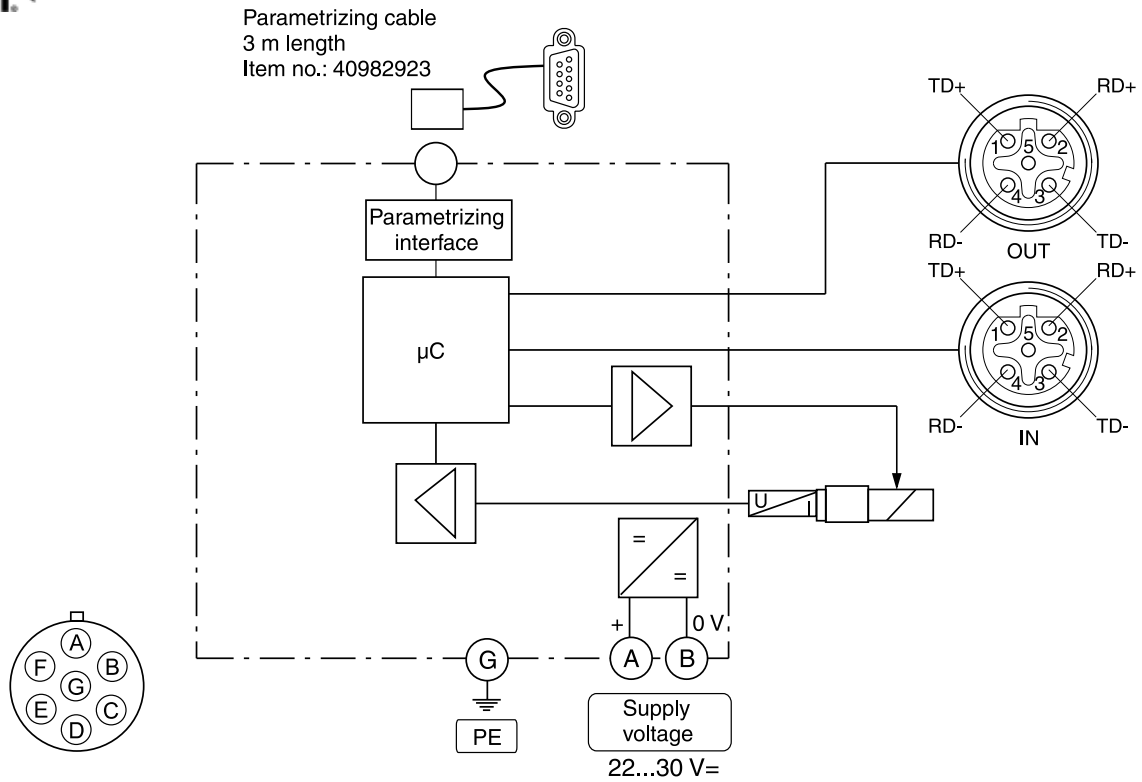

**Dimensions D1FP with EtherCAT**

