

Characteristics

The direct operated control valves D1FP with freely configurable control circuit of the nominal size NG06 (CETOP 03) and D3FP of the nominal size NG10 (CETOP 05) shows extremely high dynamics combined with maximum flow. It is the preferred choice for highest accuracy in positioning of hydraulic axis and controlling of pressure and velocity.

Driven by the patented VCD® actuator the D*FP reaches the frequency response of real servovalves. At power-down the spool moves in a defined position. All common input signals are available.

Features

- Freely configurable supervising control circuit
- Analogue sensor input
- Onboard electronics
- Real servovalve dynamics (-3 dB / 350 Hz at $\pm 5\%$ input signal)
- Max. tank pressure 350 bar (D1FP), 250 (D3FP) (with external drain port Y)
- Defined spool positioning at power-down - optional P-A/B-T or P-B/A-T or center position (for overlapped spools)

Direct Operated Proportional DC Valve Series D*FP*D



D1FP

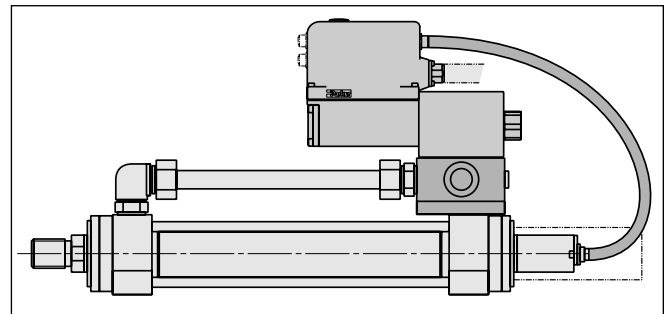
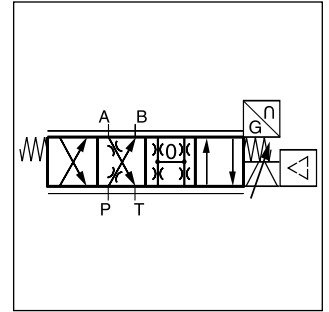
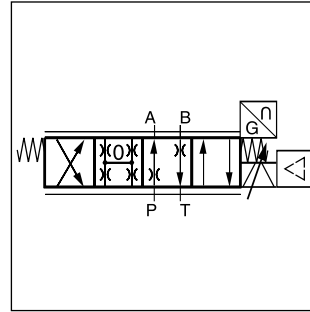
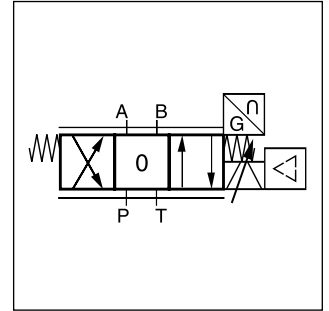

Application example

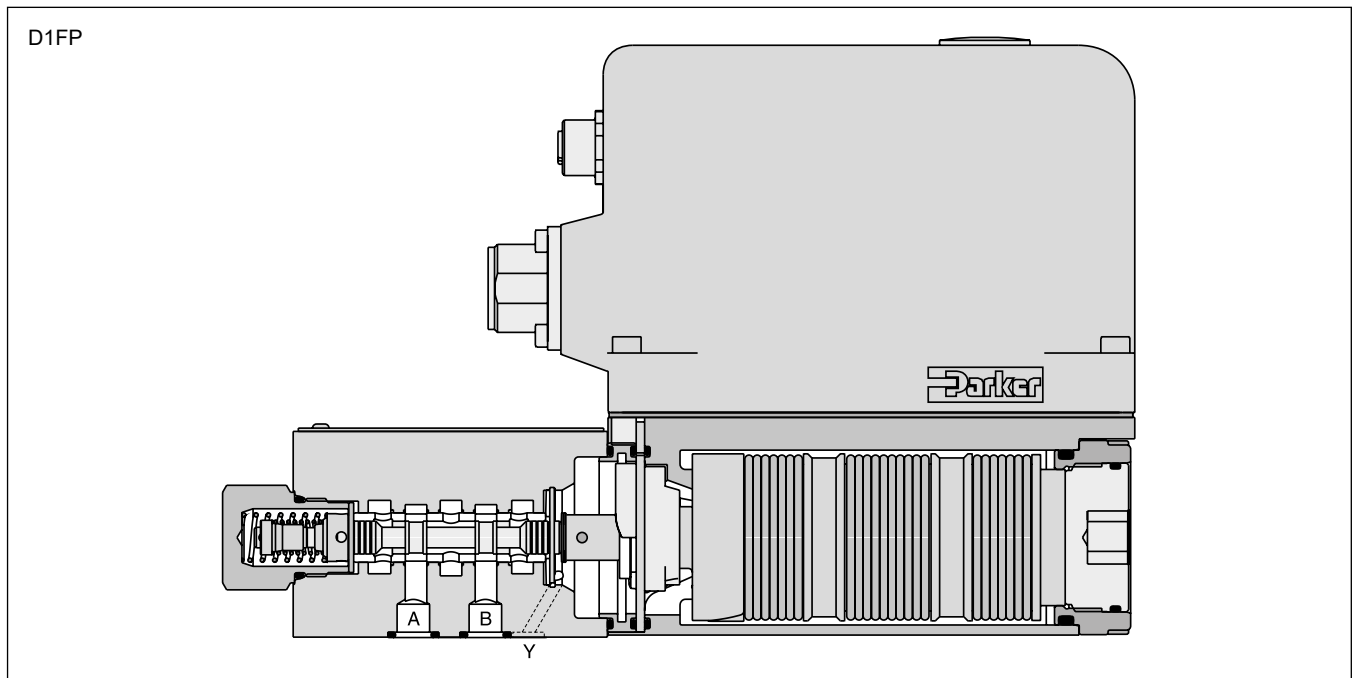

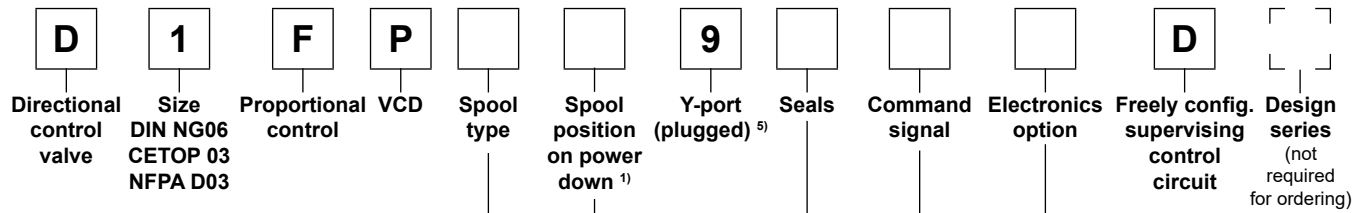

Direct Operated Proportional DC Valve Series D*FP*D

Ordering Code

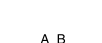
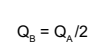
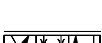
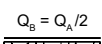

3

Code	Spool type	Flow [l/min] at Δp 35 bar per metering edge
Zerolap		
E50B		3
E50C		6
E50F		12
E50G		16
E50H		25
E50M		40
B60C	$Q_B = Q_A / 2$ 	6 / 3
B60F		12 / 6
B60G		16 / 8
B60H		25 / 12.5
B60M		40 / 20
Underlap		
E55B		3
E55C		6
E55F		12
E55G		16
E55H		25
E55M		40
Overlap		
E01B		3
E01C		6
E01F		12
E01G		16
E01H		25
E01M		40
B31C	$Q_B = Q_A / 2$ 	6 / 3
B31F		12 / 6
B31G		16 / 8
B31H		25 / 12.5
B31M		40 / 20
E02		
E02B		3
E02C		6
E02F		12
E02G		16
E02H		25
E02M		40
B32C	$Q_B = Q_A / 2$ 	6 / 3
B32F		12 / 6
B32G		16 / 8
B32H		25 / 12.5
B32M		40 / 20

Code	Connection type
0	6 + PE acc. EN175201-804
5	11 + PE acc. EN175201-804
7	6 + PE + Enable

Code	Signal	Function
B	+/- 10 V	0...+10 V -> P-A
E	+/- 20 mA	0...+20 mA -> P-A
K	+/- 10 V	0...+10 V -> P-B
S	4...20 mA	12...20 mA -> P-A

Code	Seals
N	NBR
V	FPM
H	for HFC fluid

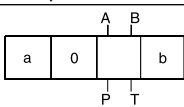
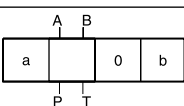
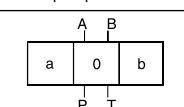
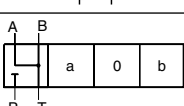
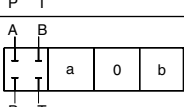
Code	Spool position at power down
A ²⁾	
B ²⁾	
C ³⁾	
H ⁴⁾	
J ⁴⁾	

Note:

Adapter plate for ISO 4401 to ISO 10372 size 04, Ordering code HAP04WV06-1661

Please order connector separately, see catalogue MSG11-3500/UK, chapter 3 accessories.

Parametrizing cable OBE -> RS232, item no. 40982923

- ¹⁾ On power down the spool moves in a defined position. This cannot be guaranteed in case of single flow path on the control edge A – T resp. B – T with pressure drops above 120 bar or contamination in the hydraulic fluid.
- ²⁾ Approx. 10 % opening, only zerolap and underlap spools.
- ³⁾ Only for overlap spools.
- ⁴⁾ Not for flow code M (40 l/min).
- ⁵⁾ Plug in the Y-port needs to be removed at tank pressure >35 bar.

Ordering Code

Direct Operated Proportional DC Valve Series D*FP*D

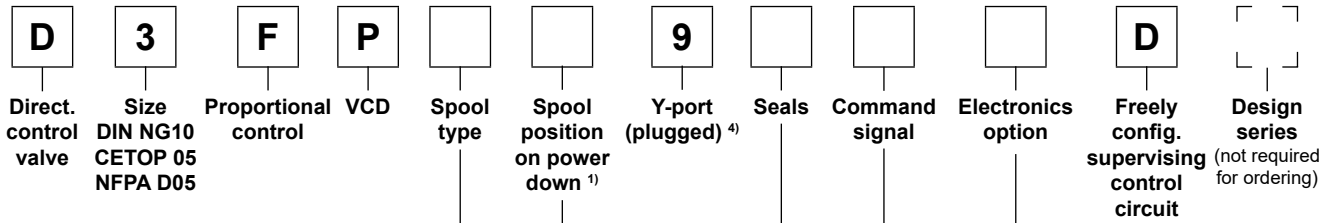

Code	Spool type	Flow [l/min] at Δp 35 bar per metering edge
Zerolap		
E50P		50
E50Y		100
B60P	$Q_B = Q_A/2$ 	50
B60Y	$Q_B = Q_A/2$ 	100
Underlap approx. -0.5 %		
E55P		50
E55Y		100
Overlap		
E01P		50
E01Y		100
E02P		50
E02Y		100
B31P	$Q_B = Q_A/2$ 	50 / 25
B31Y		100 / 50
B32P	$Q_B = Q_A/2$ 	50 / 25
B32Y		100 / 50

Code	Connection type
0	6 + PE acc. EN175201-804
5	11 + PE acc. EN175201-804
7	6 + PE + Enable

Code	Signal	Function
B	+/- 10 V	0...+10 V -> P-A
E	+/- 20 mA	0...+20 mA -> P-A
K	+/- 10 V	0...+10 V -> P-B
S	4...20 mA	12...20 mA -> P-A

Code	Seals
N	NBR
V	FPM
H	for HFC fluid

Code	Spool pos. at power down
A ²⁾	
B ²⁾	
C ³⁾	

3

For regenerative and hybrid function please refer to solutions with sandwich- and adaptor plates "A10-1664 / A10-1665L / H10-1662 / H10-1666L" in catalogue MSG11-3500/UK, chapter 12.

Please order connector separately, see catalogue HY11-3500/UK, chapter 3 accessories.

Parametrizing cable OBE -> RS232, item no. 40982923

- ¹⁾ On power down the spool moves in a defined position. This cannot be guaranteed in case of single flow path on the control edge A – T resp. B – T with pressure drops above 120 bar or contamination in the hydraulic fluid.
- ²⁾ Approx. 10 % opening, only zerolap spools and underlap spools.
- ³⁾ Only for overlap spools.
- ⁴⁾ Plug in the Y-port needs to be removed at tank pressure >35 bar.

Direct Operated Proportional DC Valve Series D*FP*D

Technical Data

General		
Design		Direct operated servo proportional DC valve
Actuation		VCD® actuator
Size		NG06 / CETOP03 / NFPA D03, NG10 / CETOP05 / NFPA D05
Mounting interface		DIN 24340 / ISO 4401 / CETOP RP121 / NFPA
Mounting position		unrestricted
Ambient temperature	[°C]	-20...+50
MTTF _D value ¹⁾	[years]	150
Weight	[kg]	5.0 (D1FP), 6.5 (D3FP)
Vibration resistance	[g]	10 Sinus 5...2000 Hz acc. IEC 68-2-6 10 (RMS) Random noise 20...2000 Hz acc. IEC 68-2-36 15 Shock acc. IEC 68-2-27
Hydraulic		
Max. operating pressure	[bar]	Ports P, A, B 350, port T 35 for internal drain, 350 (D1FP), 250 (D3FP) for external drain, port Y 35 ²⁾
Fluid		Hydraulic oil according to DIN 51524 ... 535, other on request
Fluid temperature	[°C]	-20...+60 (NBR: -25...+60)
Viscosity permitted	[cSt]/mm ² /s	20...400
Viscosity recommended	[cSt]/mm ² /s	30...80
Filtration		ISO 4406; 18/16/13
Nominal flow		
at Δp=35 bar per control edge ³⁾	[l/min]	3 / 6 / 12 / 16 / 25 / 40 (D1FP), 50 / 100 (D3FP)
Flow maximum	[l/min]	90 at Δp=350 bar over two control edges (D1FP), 150 (D3FP)
Leakage at 100 bar	[ml/min]	< 400 (zerolap spool); < 50 (D1FP overlap spool); < 100 (D3FP overlap spool)
Opening point	[%]	set to 23 (D1FP), 19 (D3FP) commande signal (see flow characteristics)
Static / Dynamic		
Step response at 100 % step ⁴⁾	[ms]	< 3.5 (D1FP), < 6 (D3FP)
Frequency response (±5 % signal) ⁴⁾	[Hz]	350 amplitude ratio -3 dB, 350 phase lag -90° (D1FP), 200 amplitude ratio -3 dB, 200 phase lag -90° (D3FP)
Hysteresis	[%]	< 0.05
Sensitivity	[%]	< 0.03
Temperature drift	[%/K]	< 0.025
Electrical characteristics		
Duty ratio	[%]	100
Protection class		IP65 in accordance with EN 60529 (with correctly mounted plug-in connector)
Supply voltage/ripple	[V]	DC 22 ... 30, electric shut-off at < 19, ripple < 5 % eff., surge free
Current consumption max.	[A]	3.5
Pre-fusing	[A]	4.0 medium lag
Input signal		
Code B, (K)	Voltage	[V] 10...0...-10, ripple < 0.01 % eff., surge free, 0...+10 V P->A (P->B)
	Impedance	[kOhm] 100
Code E	Current	[mA] 20...0...-20, ripple < 0.01 % eff., surge free, 0...+20 mA P->A
	Impedance	[Ohm] < 250
Code S	Current	[mA] 4...12...20, ripple < 0.01 % eff., surge free, 12...20 mA P->A
	Impedance	[Ohm] < 250
Differential input max.		
Code 0	[V]	30 for terminal D and E against PE (terminal G)
Code 5	[V]	30 for terminal 4 and 5 against PE (terminal \perp)
Code 7	[V]	30 for terminal D and E against PE (terminal G)
Enable signal (only code 5/7)	[V]	5...30, Ri = > 8 kOhm
Diagnostic signal	[V]	+10...0...-10 / +12.5 error detection, rated max. 5 mA
EMC		EN 61000-6-2, EN 61000-6-4
Electrical connection	Code 0/7	6 + PE acc. EN 175201-804
	Code 5	11 + PE acc. EN 175201-804
Wiring min.	Code 0/7	[mm ²] 7x1.0 (AWG 16) overall braid shield
	Code 5	[mm ²] 8x1.0 (AWG 16) overall braid shield
Wiring length max.	[m]	50

¹⁾ If valves with onboard electronics are used in safety-related parts of control systems, in case the safety function is requested, the valve electronics voltage supply is to be switched off by a suitable switching element with sufficient reliability.

²⁾ For applications with p_r>35 bar (max. 350 bar) the Y-port has to be connected and the plug in the Y-port has to be removed.

³⁾ Flow rate for different Δp per control edge: $Q_x = Q_{Nom.} \cdot \sqrt{\frac{\Delta p_x}{\Delta p_{Nom.}}}$

⁴⁾ Measured with load (100 bar pressure drop/two control edges).

Characteristic Curves

Flow curves

(Overlapped spool set to opening point 23 %)

at $\Delta p = 35$ bar per metering edge

Spool type **E01/E50**

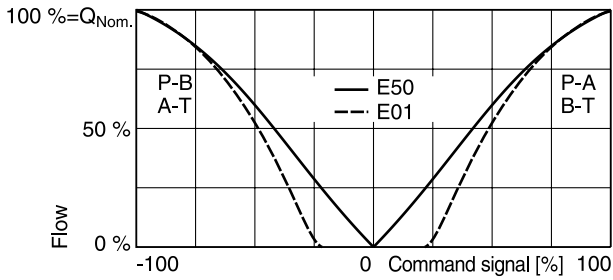

Spool type **B31/B60**

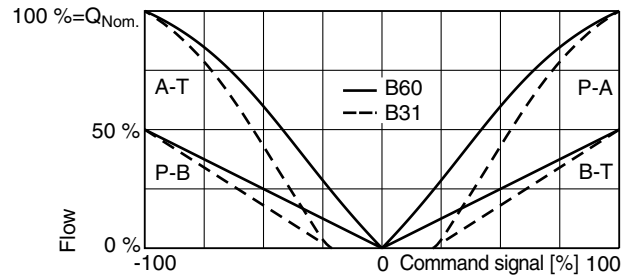

Pressure gain

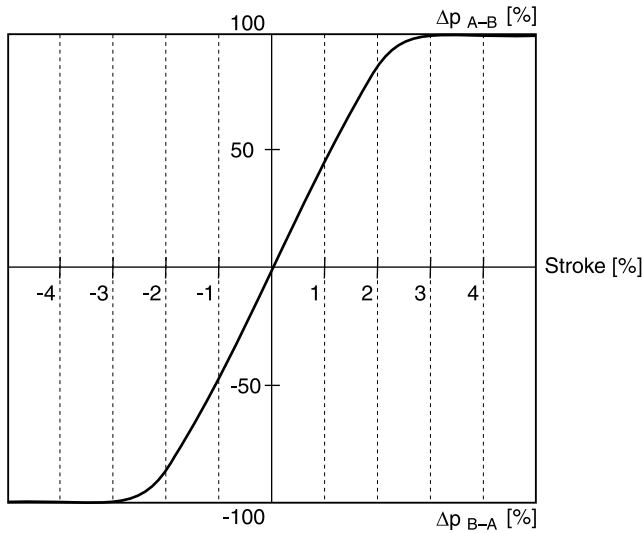

Frequency response

± 5 % command signal

± 90 % command signal

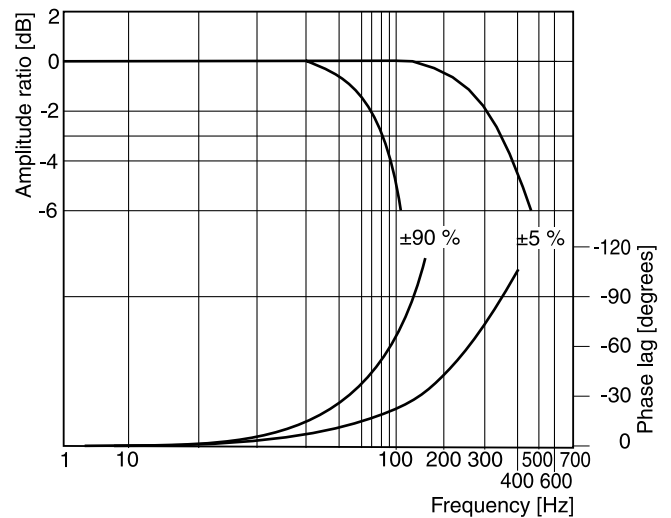

All characteristic curves measured with HLP46 at 50 °C.

Characteristic Curves

Flow curves

(Overlapped spool set to opening point 19 %)

at $\Delta p = 35$ bar per metering edge

Spool type **E50/E55, E01/E02**

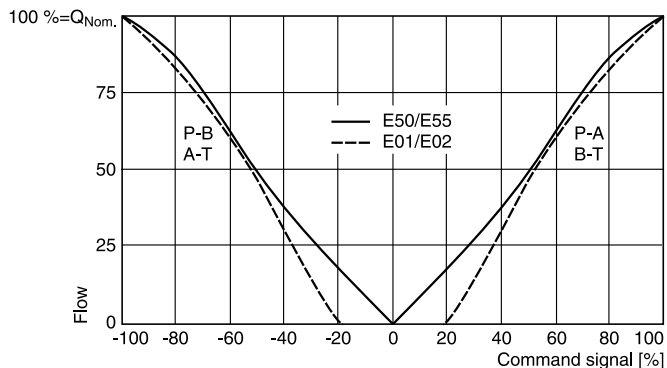

Spool type **B31/B32, B60**

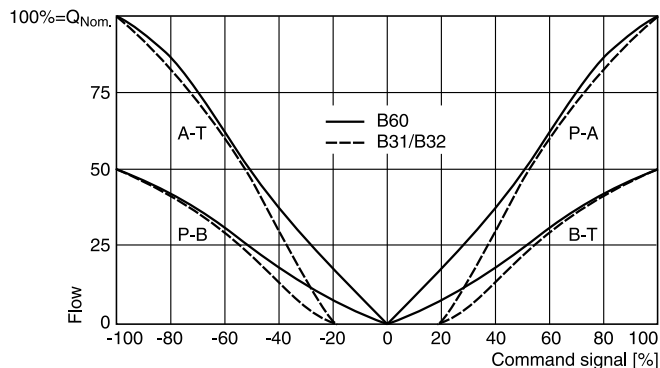

Pressure gain

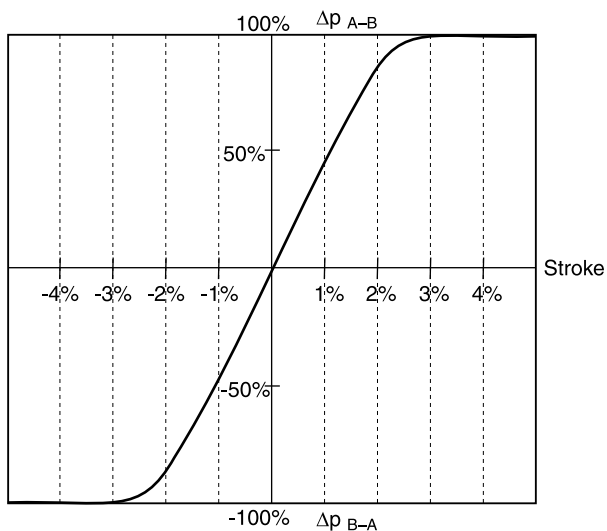

Frequency response

$\pm 5\%$ command signal

$\pm 90\%$ command signal

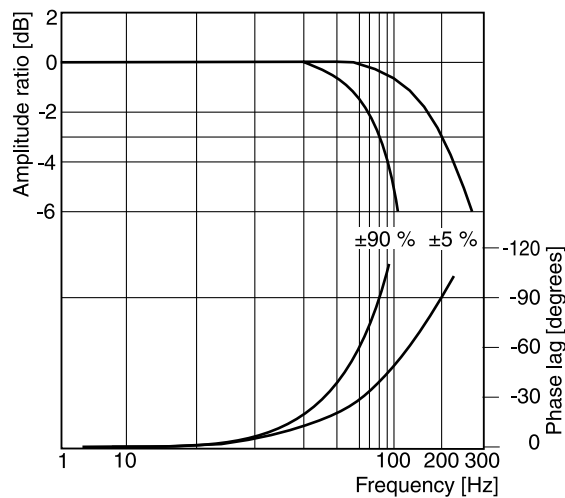

All characteristic curves measured with HLP46 at 50 °C.

D_FP_D UK.indd 25.03.24

Code 0

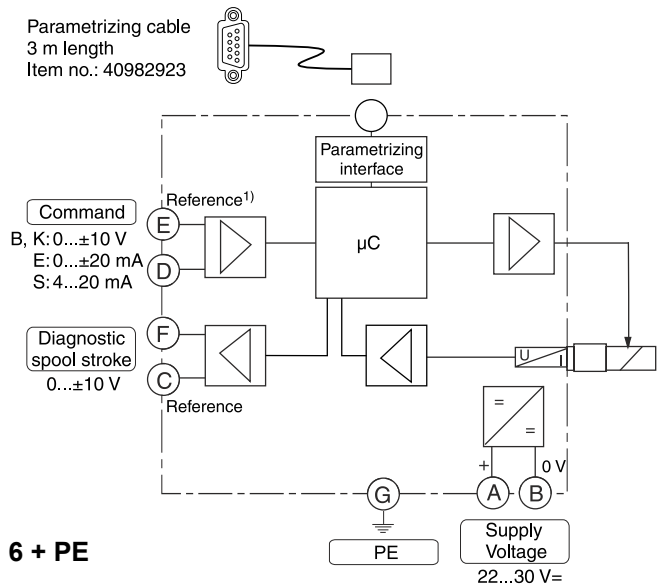

6 + PE

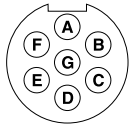

Code 5

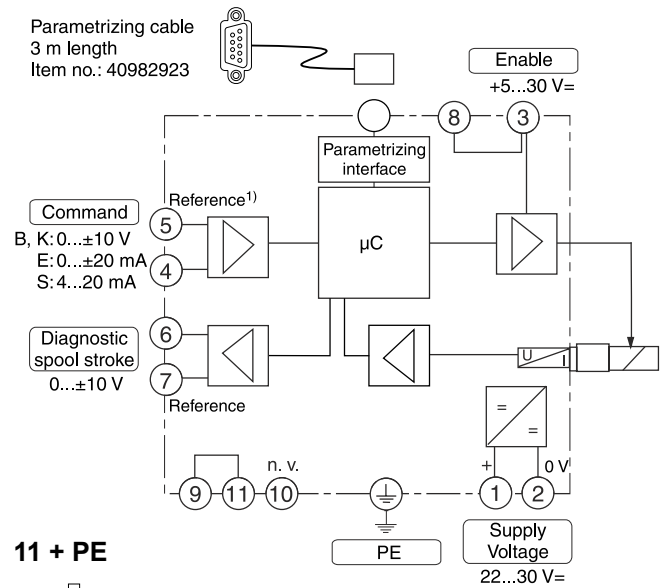

11 + PE

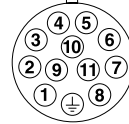

3

Code 7

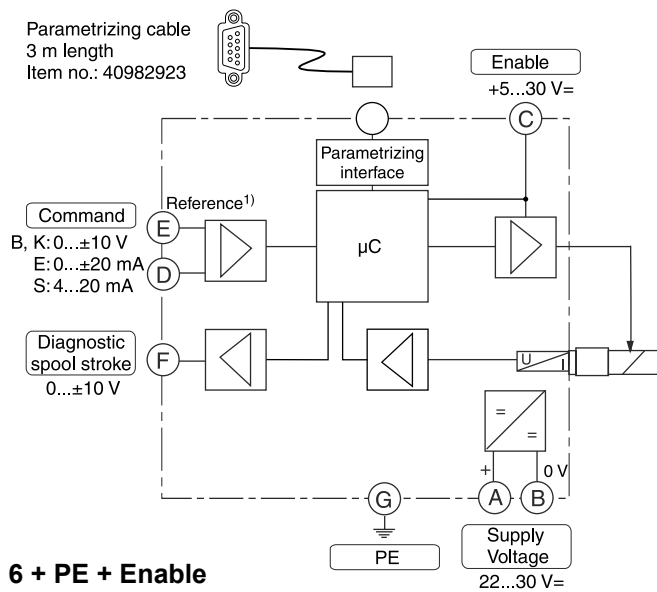

6 + PE + Enable

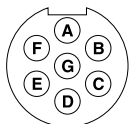

¹⁾ Do not connect with supply voltage zero.

Block Diagrams

Pin assignment analog sensor, M12 socket

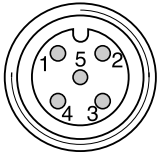

- 1: U_S
- 2: $\pm 10\text{ V}$
- 3: GND
- 4: 4 ... 20 mA +
- 5: 4 ... 20 mA -

3

Examples position control

Current 4...12...20 mA contacts at the sensor input

Wiring diagram four-wire

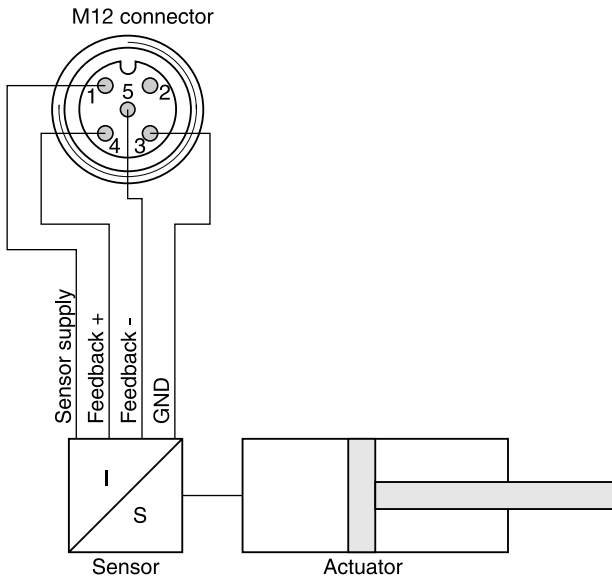

Wiring diagram two-wire

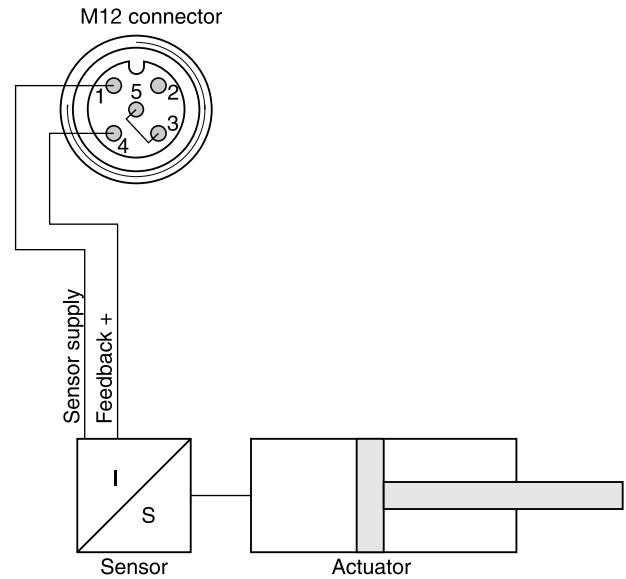

Wiring diagram three-wire

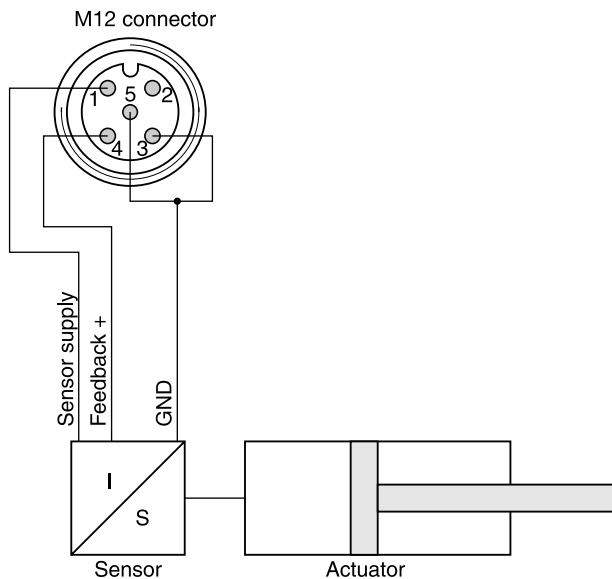

Voltage $\pm 10\text{ V}$ (1...10 V)

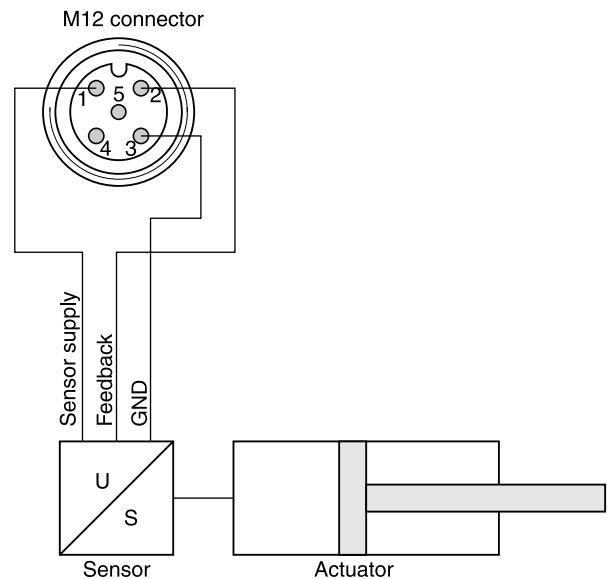

The earth connection is achieved via the shielding.

ProPxD interface program

The ProPxD software allows quick and easy setting of the digital valve electronics. Individual parameters as well as complete settings can be viewed, changed and saved via the comfortable user interface. Parameter sets saved in the non-volatile memory can be loaded to other valves of the same type or printed out for documentation purposes.

The PC software can be downloaded free of charge at www.parker.com/isde – see page “Support” or directly at www.parker.com/propxd.

Features

- Comfortable editing of valve parameters - configuration of the controller
- Saving and loading of customized parameter sets
- Executable with all Windows® operating systems from Windows® XP upwards
- Simple communication between PC and valve electronics via serial interface RS232C

The valve electronics cannot be connected to a PC with a standard USB cable – this can result in damages of PC and/or valve electronics.

The parametrizing cable may be ordered under item no. 40982923.

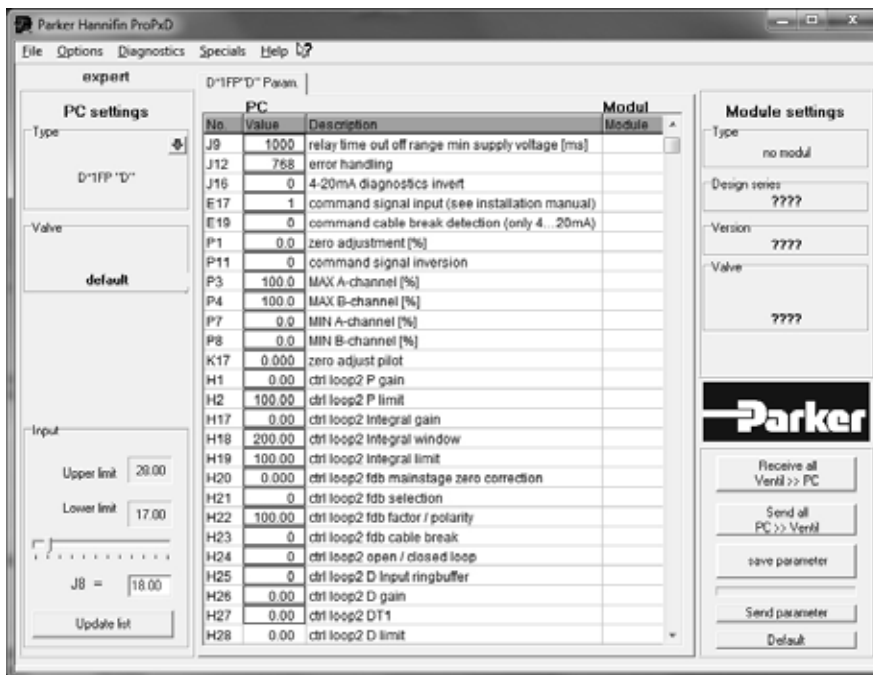





Direct Operated Proportional DC Valve Series D*FP*D

Dimensions

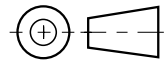
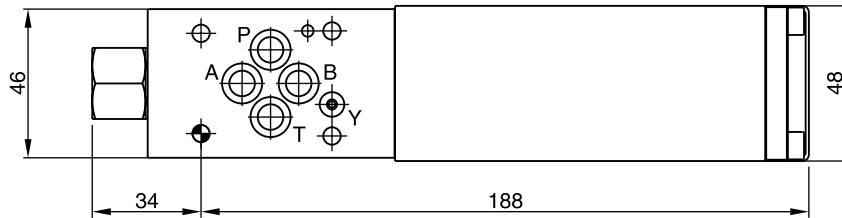
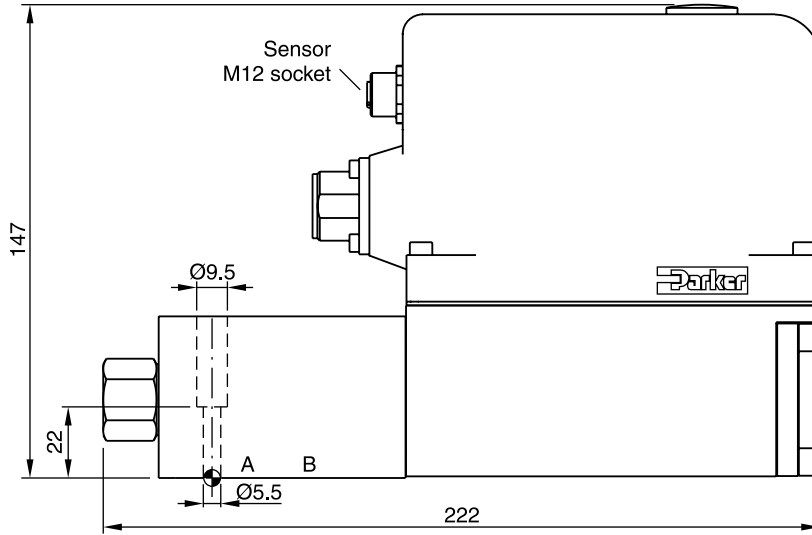
D1FP*D

3



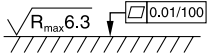



Surface finish	 Kit	 Kit	 Kit	 Kit
	BK375	4x M5x30 ISO 4762-12.9	7.6 Nm ±15 %	NBR: SK-D1FP FPM: SK-D1FP-V HFC: SK-D1FP-H

Dimensions

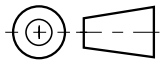
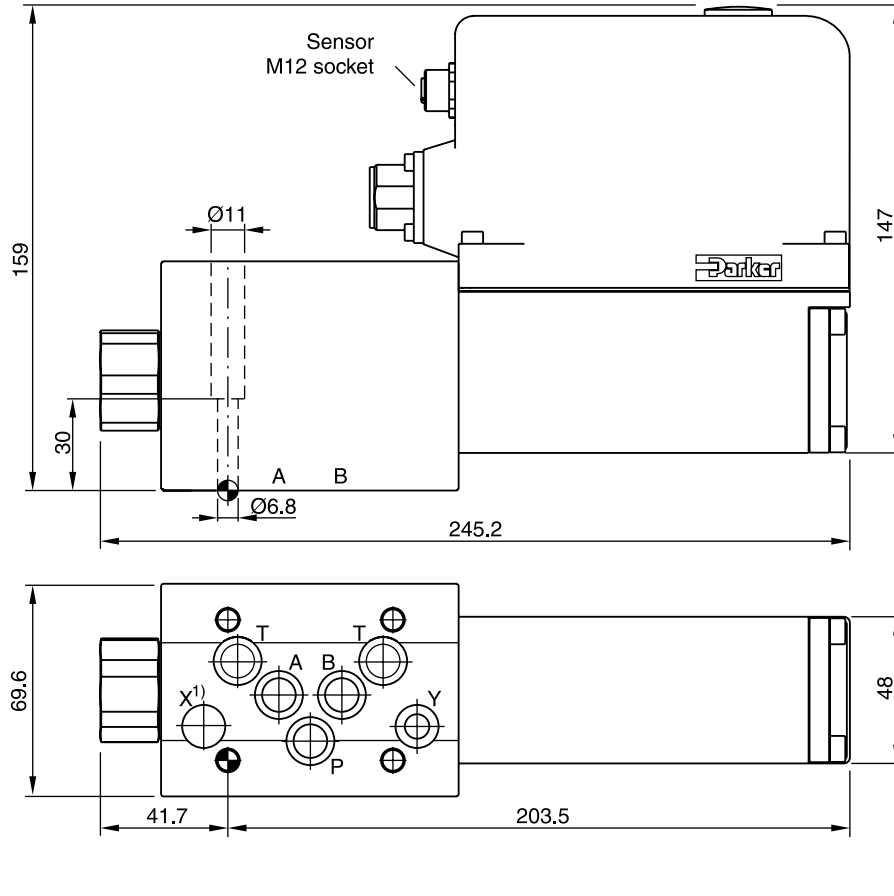
Direct Operated Proportional DC Valve Series D*FP*D

D3FP*D

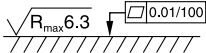

Surface finish	 Kit	 Kit	 Kit	 Kit
	BK385	4x M6x40 ISO 4762-12.9	13.2 Nm ±15 %	NBR: SK-D3FP FPM: SK-D3FP-V HFC: SK-D3FP-H