

The series of pilot operated servo proportional valves D\*1FP transfers the advantages of the Parker patented Voice Coil Drive (VCD®) to larger frame sizes and thus high flow rates. The high dynamics / high precision drive of the pilot valve allows the optimum control of the main spool and results in servo class performance of the complete valves.

The D\*1FP series is available in 5 sizes:

D31FP NG10 (CETOP 05)

D41FP NG16 (CETOP 07)

D91FP NG25 (CETOP 08) for port diam. up to 32 mm

D111FP NG32 (CETOP 10)

The safety concept works with a safe 4th position at the D1FP pilot valve. This ensures that the main stage is hydraulically balanced at power down and allows to have the main spool spring centered (for overlapped spools) or approximately 10 % spring offset to spool position A or B (for zerolap spools).



D41FP

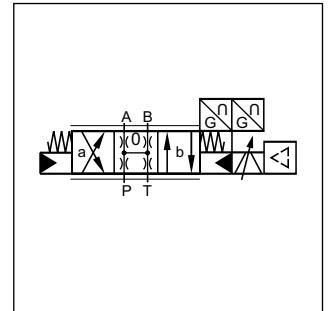

D\*1FPE

**3**

**Features**

- High dynamics
- High flow
- Defined spool positioning at power-down - optional  
P-A/B-T or P-B/A-T or center position  
(for overlapped spools)
- Onboard electronics

**D41FPE52**

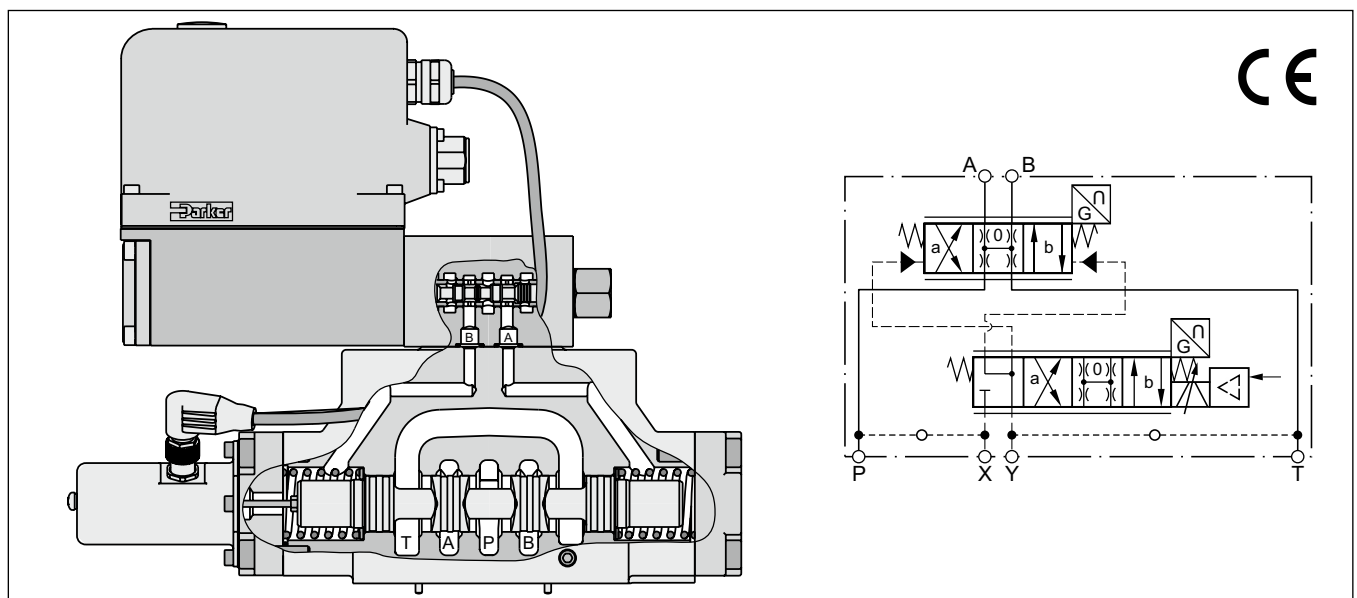

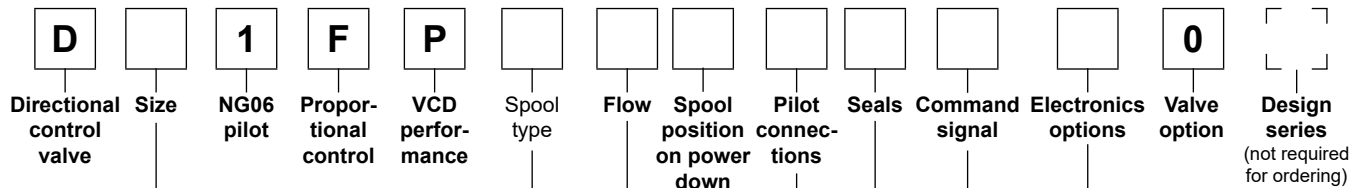

**3**

Code	Size
3	NG10 / CETOP 05
4	NG16 / CETOP 07
9 <sup>1)</sup>	NG25 / CETOP 08
11	NG32 / CETOP 10

Code	Connection type
0	6+PE acc. EN175201-804
5	11+PE acc. EN175201-804
7	6+PE + enable

Code	Spool type overlap
E01	
E02	
B31	$Q_B = Q_A/2$ 
B32	$Q_B = Q_A/2$ 
zerolap	
E52	
B61	$Q_B = Q_A/2$ 

Code	Signal	Function
B	0...±10 V	0...+10 V P -> B
E	0...±20 mA	0...+20 mA P -> B
K	0...±10 V	0...+10 V P -> A
S	4...20 mA	12...20 mA P -> A

Code	Seals
N	NBR
V	FPM
H	for HFC fluid

Code	Inlet	Drain
1	internal	external
2	external	external
4	internal	internal
5	external	internal

Code	Flow [l/min] at $\Delta p = 5$ bar per metering edge			
	D31	D41	D91	D111
D	90	—	—	—
E	120	—	—	—
F	—	200	—	—
H	—	—	450	—
L	—	—	—	1000

Code	Spool pos. on power down
A <sup>2)</sup>	
B <sup>2)</sup>	
C <sup>3)</sup>	

Short delivery time  
for all variations

Please order connector separately. See chapter 3 accessories.  
 Parametrizing cable OBE -> RS232, item no. 40982923

<sup>1)</sup> For enlarged connections  $\varnothing 32$  mm.  
<sup>2)</sup> Approx. 10 % opening, only zero lapped spools.  
<sup>3)</sup> For overlapped spools.

<b>General</b>					
Design	Pilot operated servo proportional DC valve				
Actuation	VCD®-actuator				
Size	<b>NG10 (CETOP 05)</b>	<b>NG16 (CETOP 07)</b>	<b>NG25 (CETOP 08)</b>	<b>NG32 (CETOP 10)</b>	
	<b>D31</b>	<b>D41</b>	<b>D91</b>	<b>D111</b>	
Mounting Interface	DIN 24340 / ISO 4401 / CETOP RP121 / NFPA				
Mounting position	unrestricted				
Ambient temperature	[°C] -20...+50				
MTTF <sub>D</sub> value <sup>1)</sup>	[years] 75				
Weight	[kg] 11.3	14.2	23.5	64.5	
Vibration resistance	[g] 10 Sinus 5...2000 Hz acc. IEC 68-2-6 10 (RMS) Random noise 20...2000 Hz acc. IEC 68-2-36 15 Shock acc. IEC 68-2-27				
<b>Hydraulic</b>					
Max. operating pressure	[bar]	Internal pilot drain P, A, B, X 350; T, Y 35 External pilot drain P, A, B, T, X 350; Y 35			
Fluid	Hydraulic oil according to DIN 51524 ... 535, other on request				
Fluid temperature	[°C]	-20...+60 (NBR: -25...+60)			
Viscosity permitted	[cSt]/[mm <sup>2</sup> /s]	20...400			
Viscosity recommended	[cSt]/[mm <sup>2</sup> /s]	30...80			
Filtration	ISO 4406: 18/16/13				
Nominal flow at Δp = 5 bar per control edge <sup>2)</sup>	[l/min]	120	200	450	1000
Max. recommended flow (standard)	[l/min]	250	600	1000	3000
Leakage at 100 bar	[ml/min]	200	200	600	1000
Overlapped spool	[ml/min]	900	900	1000	5000
Zerolapped spool	[ml/min]	< 500			
Pilot	[ml/min]	set to 10 command signal (see flow characteristics)			
Opening point	[°]	20...350			
Pilot supply pressure	[bar]	10			
Pilot flow during step response at 210 bar	[l/min]	12	24	40	
<b>Static / Dynamic</b>					
Step response at 100 % stroke <sup>3)</sup>	[ms]	10	13	19	45
Frequency response	[Hz]	128	95	95	40
Amplitude ±5 % at 210 bar	[Hz]	118	95	90	75
Phase ±5 % at 210 bar	[Hz]	< 0.1			
Hysteresis	[%]	< 0.05			
Sensitivity	[%]	< 0.025			
Temperature drift of center position	[%/K]				
<b>Electrical</b>					
Duty ratio	[%]	100			
Protection class		IP65 in accordance with EN 60529 (with correctly mounted plug-in connector)			
Supply voltage / ripple	[V]	22...30, ripple < 5 % eff., surge free			
Current consumption max.	[A]	3.5			
Pre-fusing	[A]	4.0 A medium lag			
Input signal Code K (B) Voltage	[V]	+10...0...-10, ripple < 0.01 % eff., surge free, 0...+10 V P→A (P→B)			
Code E Impedance	[kOhm]	100			
Code E Current	[mA]	+20...0...-20, ripple < 0.01 % eff., surge free, 0...+20 mA P→B			
Code S Impedance	[Ohm]	<250			
Code S Current	[mA]	4...12...20, ripple < 0.01 % eff., surge free, 12...20 mA P→A			
Code S Impedance	[Ohm]	<250			
Input Capacitance typ.	[nF]	1			
Differential input max. Code 0	[V]	30 for terminal D and E against PE (terminal G) 11 for terminal D and E against 0V (terminal B)			
Code 5	[V]	30 for terminal 4 and 5 against PE (terminal ↓) 11 for terminal 4 and 5 against 0V (terminal 2)			
Code 7	[V]	30 for terminal D and E against PE (terminal G)			
Enable signal Code 5/7	[V]	5...30, Ri > 8 kOhm			
Diagnostic signal	[V]	+10...0...-10 / +12.5 V (overload), rated max. 5 mA			
EMC		EN 61000-6-2, EN 61000-6-4			
Electrical connection Code 0/7		6 + PE acc. EN 175201-804			
Code 5		11 + PE acc. EN 175201-804			
Wiring min. Code 0/7	[mm <sup>2</sup> ]	7 x 1.0 (AWG16) overall braid shield			
Code 5	[mm <sup>2</sup> ]	8 x 1.0 (AWG16) overall braid shield			
Wiring length max.	[m]	50			

<sup>1)</sup> If valves with onboard electronics are used in safety-related parts of control systems, in case the safety function is requested, the valve electronics voltage supply is to be switched off by a suitable switching element with sufficient reliability.

<sup>2)</sup> Flow rate for different Δp per control edge:  $Q_x = Q_{Nom.} \cdot \sqrt{\frac{\Delta p_x}{\Delta p_{Nom.}}}$

<sup>3)</sup> Measured with load (210 bar pressure drop/two control edges).

**Wiring**

Code 0, 6 + PE acc. EN 175201-804

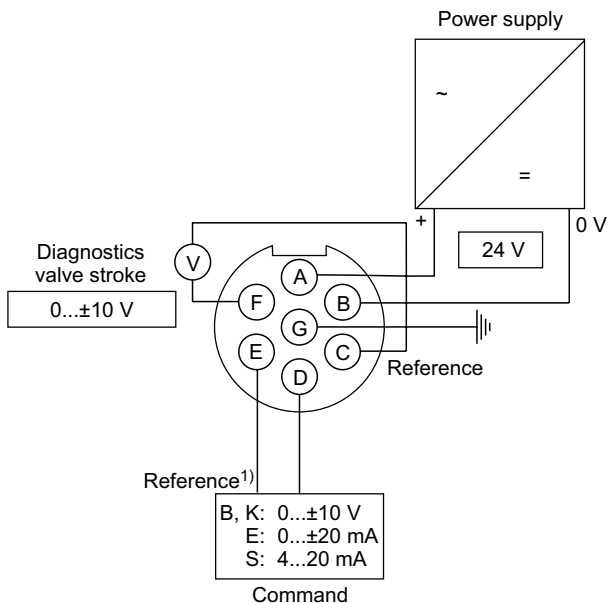

Code 5, 11 + PE acc. EN 175201-804

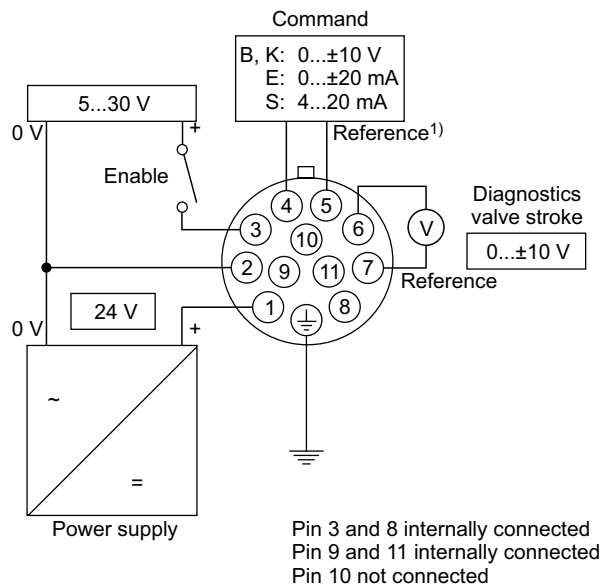

Code 7, 6 + PE acc. EN 175201-804 + enable

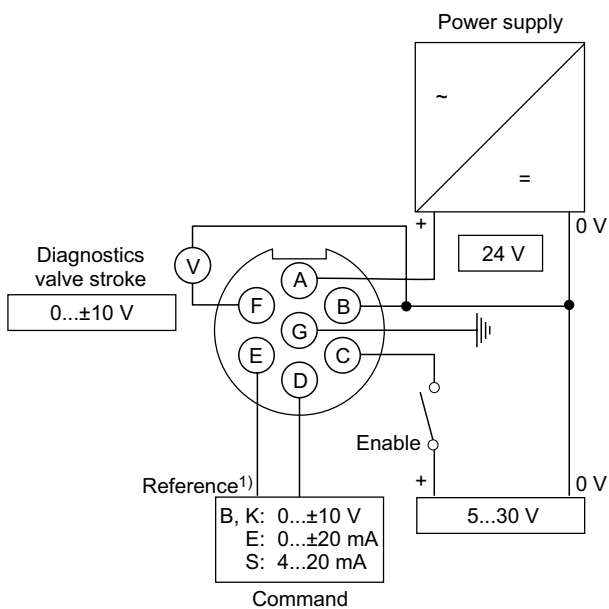

<sup>1)</sup> Do not connect with supply voltage zero.

**ProPxD interface program**

The ProPxD software allows quick and easy setting of the digital valve electronics. Individual parameters as well as complete settings can be viewed, changed and saved via the comfortable user interface. Parameter sets saved in the non-volatile memory can be loaded to other valves of the same type or printed out for documentation purposes.

The PC software can be downloaded free of charge at [www.parker.com/isde](http://www.parker.com/isde) – see page “Support” or directly at [www.parker.com/propxd](http://www.parker.com/propxd).

**Features**

- Comfortable editing of valve parameters
- Saving and loading of customized parameter sets
- Executable with all Windows® operating systems from Windows® XP upwards
- Simple communication between PC and valve electronics via serial interface RS232C

The valve electronics cannot be connected to a PC with a standard USB cable – this can result in damages of PC and/or valve electronics.

**The parametrizing cable may be ordered under item no. 40982923.**

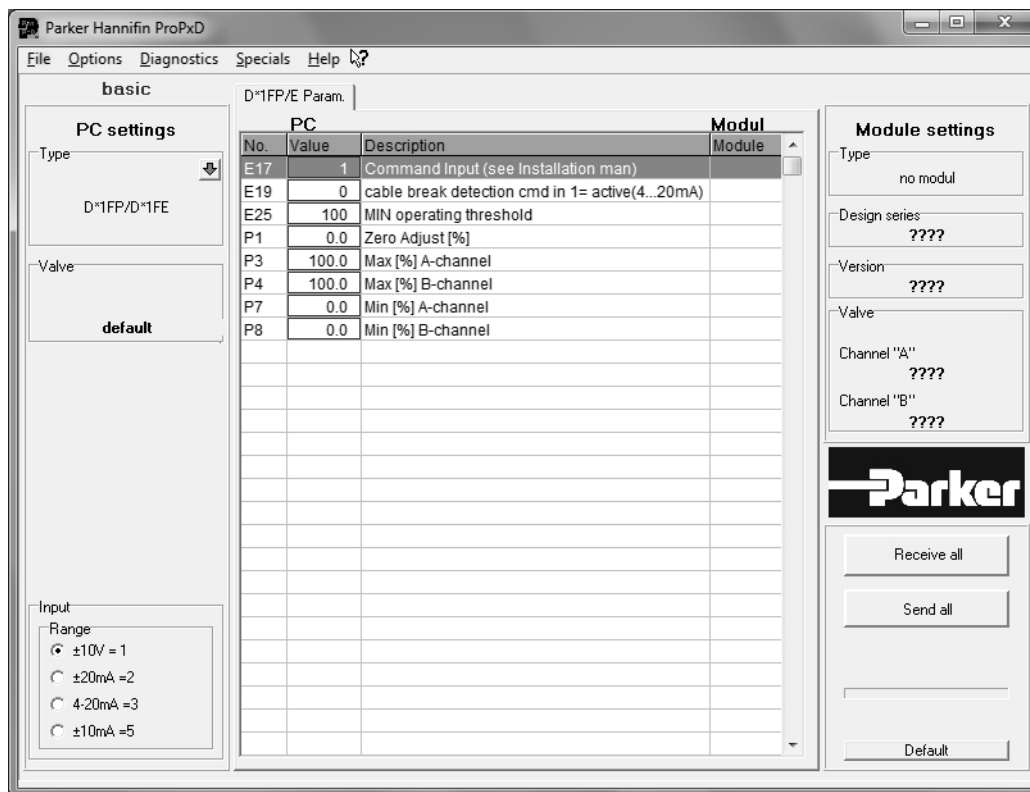

**Frequency response**

±5 % / ±25 % / ±90 % command signal  
 Dynamics at 210 bar pilot supply pressure

**D31FP**

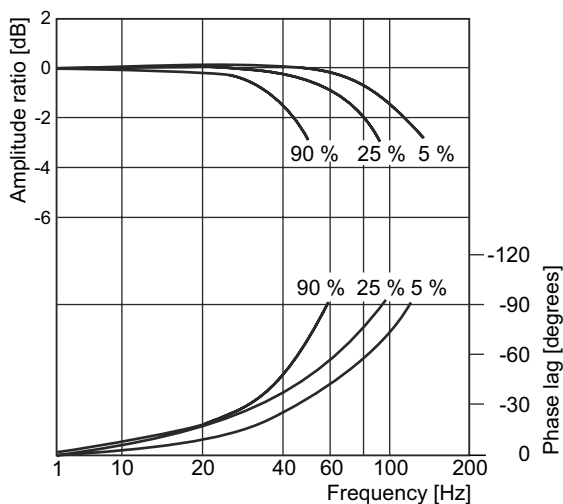

**D41FP**

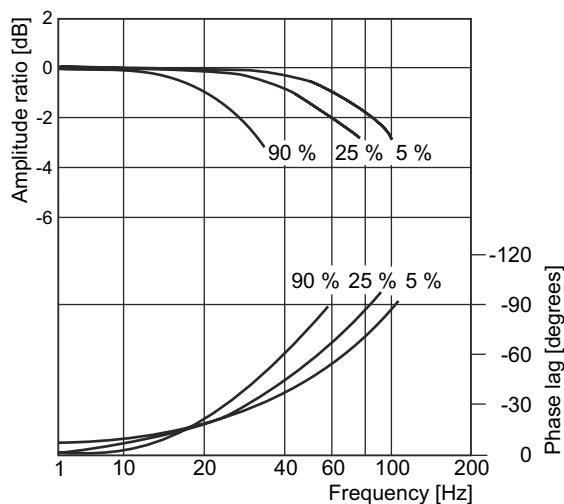

**D91FP**

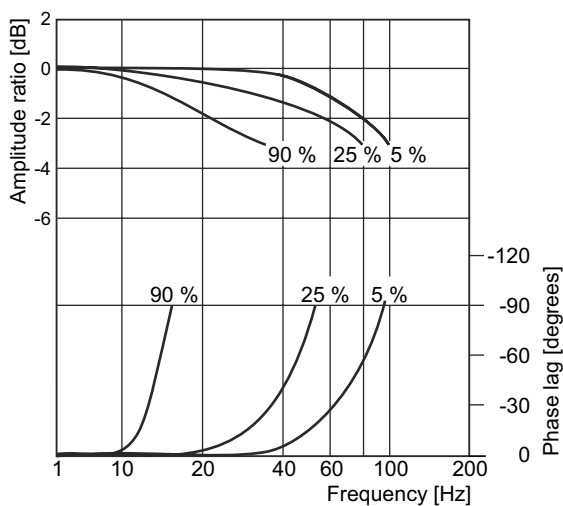

**D111FP**

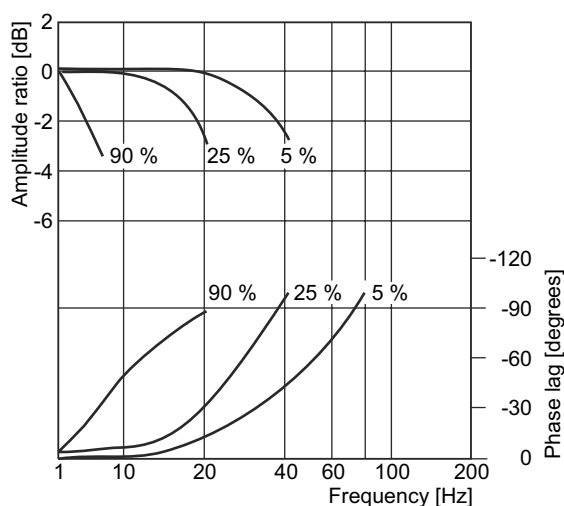

All characteristic curves measured with HLP46 at 50 °C.

D\_1FP UK.indd 25.03.24

**Flow curves D\*1FPB/E**

(Overlapped spool set to opening point 10 %)  
 at  $\Delta p = 5$  bar per metering edge

**D31FP**

spool type E01/02/52, B31/32/61

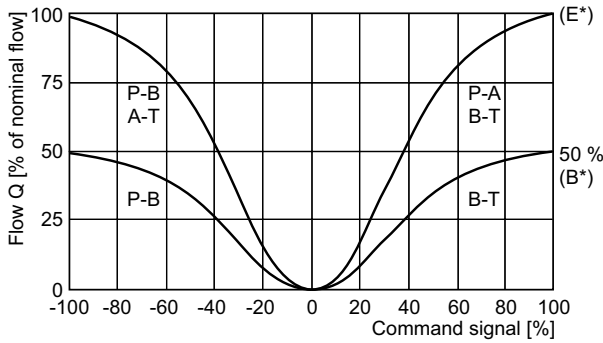

**D41FP**

spool type E01/02/52, B31/32/61

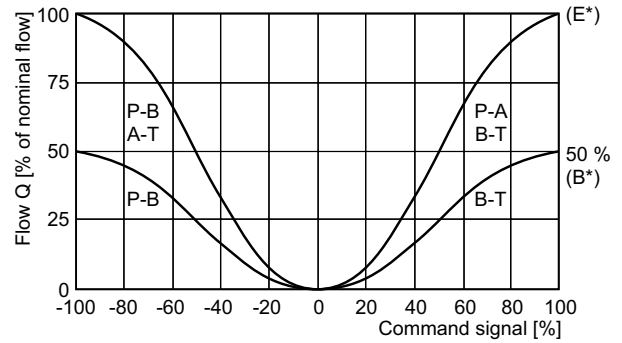

**Flow curves**

**D91FP**

Spool type E01/02/52, B31/32/61

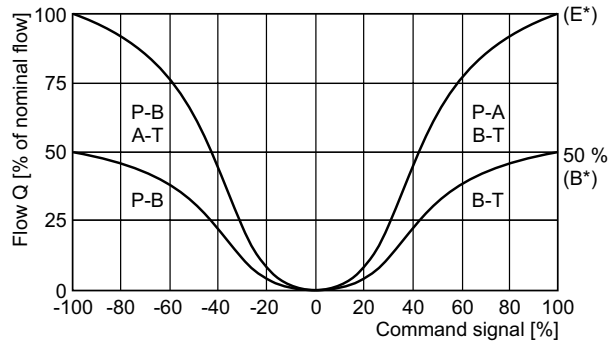

**D111FP**

Spool type E01/02/52, B31/32/61

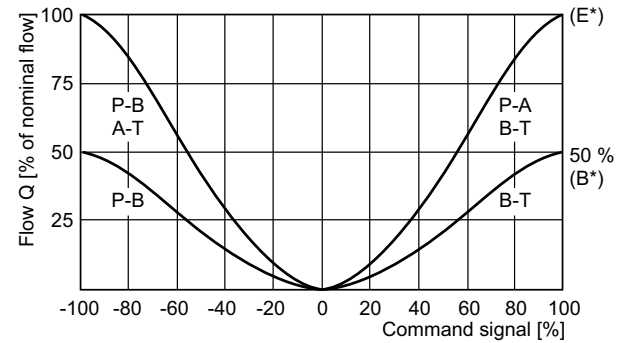

**3**

**Pilot oil inlet (supply) and outlet (drain)**

○ open, ● closed

Pilot oil		B	C
Inlet	Drain		
internal	external	○	●
external	external	●	●
internal	internal	○	○
external	internal	●	○

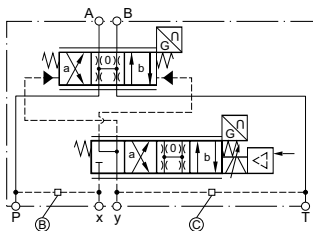

**3**

**D31FPB/E**

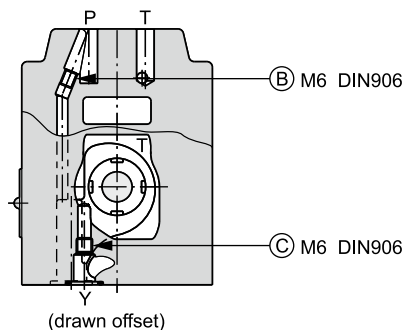

**D41FPB/E**

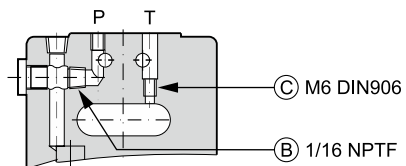

**D91FPB/E**

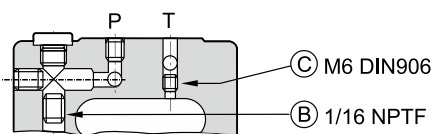

**D111FPB/E**

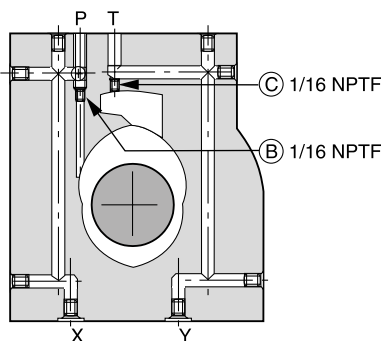

**D31FP**

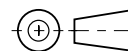
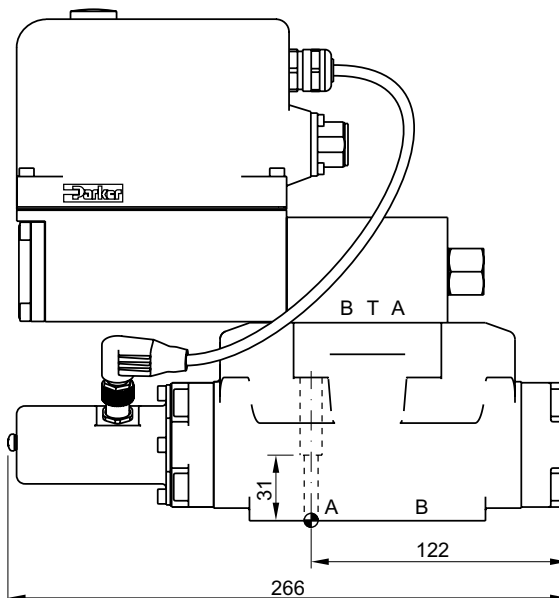
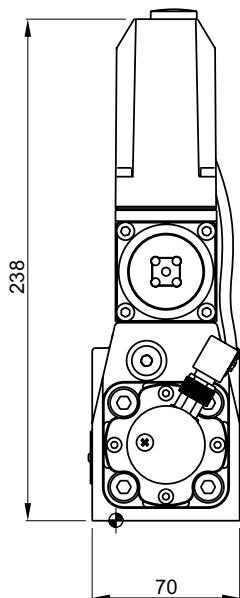

Surface finish	Kit	Kit	Kit	Kit
	BK385	4x M6x40 ISO 4762-12.9	13.2 Nm ±15 %	NBR: SK-D31FP FPM: SK-D31FP-V

**D41FP**

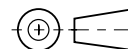
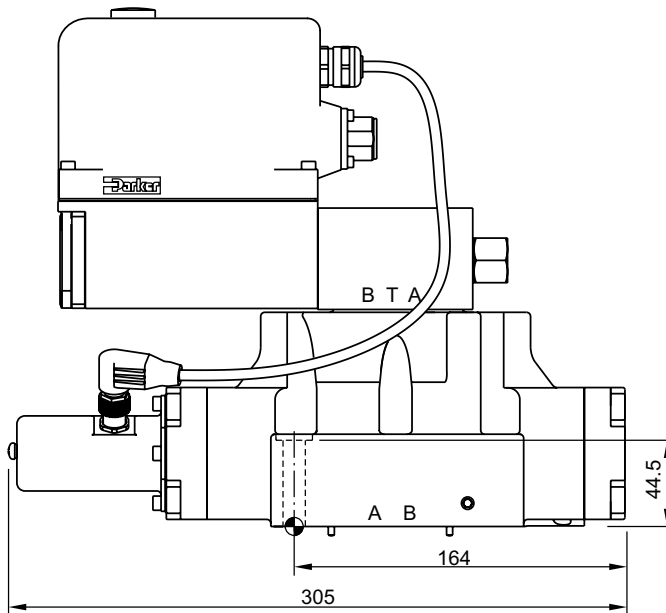
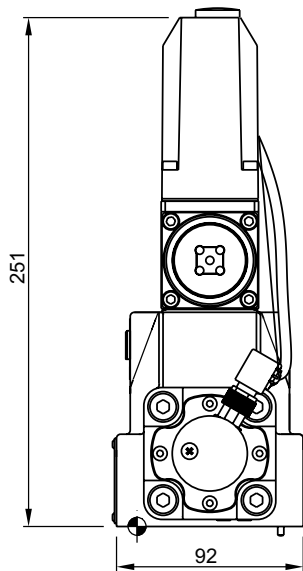

Surface finish	Kit	Kit	Kit	Kit
	BK320	2x M6x55 4x M10x60 ISO 4762-12.9	13.2 Nm ±15 % 63 Nm ±15 %	NBR: SK-D41FP FPM: SK-D41FP-V

**D91FP**

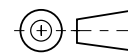
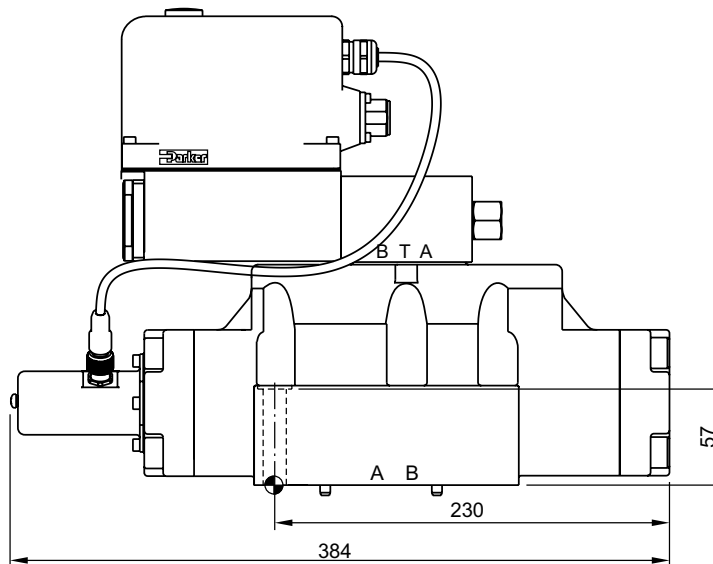
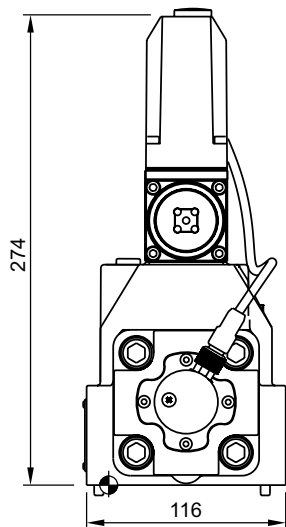

Surface finish	Kit	Kit	Kit	Kit
	BK360	6x M12x75 ISO 4762-12.9	108 Nm ±15 %	NBR: SK-D81/D91FP FPM: SK-D81/D91FP-V

**D111FP**

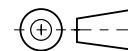
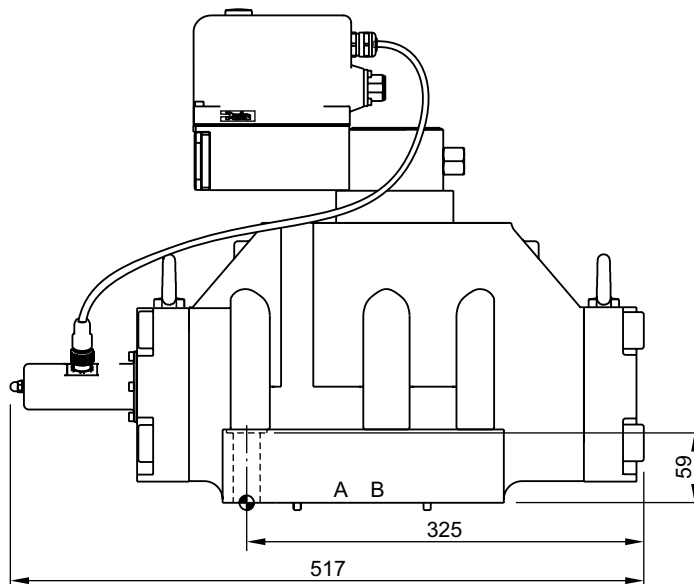
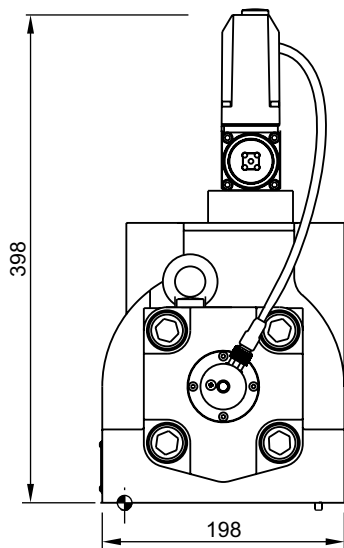

Surface finish	Kit	Kit	Kit	Kit
	BK386	6x M20x90 ISO 4762-12.9	517 Nm ±15 %	NBR: SK-D111FP FPM: SK-D111FP-V