

Characteristics / Ordering Code

Parker electronic modules PID00A-40* for rail mounting are compact, easy to install and provide time-saving wiring by disconnectable terminals. The digital design of the circuit results in good accuracy and optimal adaption for closed loop controls by a comfortable interface program.

Features

The described electronic unit combines all necessary functions for the optimal operation of closed loop controls. The most important features are:

- Extended PID controls
- Speed control with position feedback
- Differential input stage with different signal options
- Output stage with different output options
- Four-quadrant ramp function
- Status indicator
- Digital circuit design
- Parametering by USB interface
- Connection by disconnectable terminals
- Compatible to the relevant European EMC standards
- Technology function "linearization"
- Comfortable PC user software, free of charge:
www.parker.com/isde - see "Support", or directly at
www.parker.com/propxd.

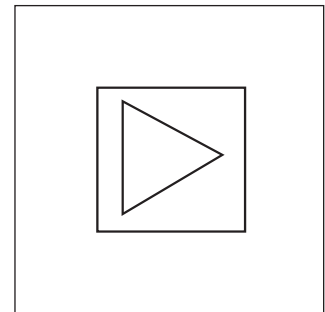
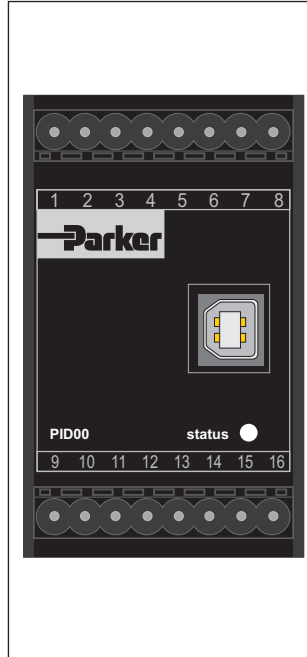

Ordering code

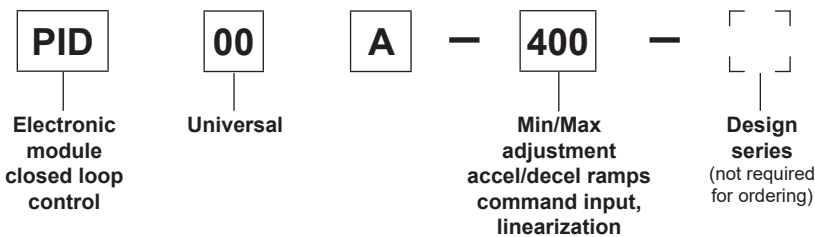

Technical data

| General | |
|---------------------------------|---|
| Model | Module package for snap-on mounting on EN 50022 rail |
| Package material | Polycarbonate |
| Inflammability class | V0 acc. UL 94 |
| Installation position | unrestricted |
| Ambient temperature range | [°C] -20...+60 |
| Protection class | IP 20 acc. EN 60529 |
| MTTF _D value | [years] 150 |
| Weight | [g] 160 |
| Electrical | |
| Duty ratio | [%] 100 |
| Supply voltage | [VDC] 18...30, ripple < 5 % eff., surge free |
| Current consumption max. | [mA] 100 |
| Pre-fusing | [mA] 500 |
| Command signal options | [V] +10...0...-10, ripple <0.01 % eff., surge free, Ri = 100 kOhm [mA] +20...0...-20, ripple <0.01 % eff., surge free, Ri = <250 Ohm [mA] 4...12...20, ripple <0.01 % eff., surge free, Ri = <250 Ohm <3.6 mA = solenoid output off, >3.8 mA = solenoid output on (acc. NAMUR NE43) |
| Input signal resolution | [%] 0.025 |
| Differential input voltage max. | [V] 30 for terminals 5 und 6 against PE (terminal 8) |
| Enable signal | [V] 0...1: Off / 5...30: On / Ri = 100 kOhm |
| Status signal | [V] 0...0.5: Off / Us: On / rated max. 15 mA |
| Monitor signal | [V] +10...0...-10, rated max. 5 mA, signal resolution 0.4 % |
| Output signal options | [V] +10...0...-10, rated max. 15 mA [mA] +20...0...-20, Ro < 500 Ohm [mA] +50...0...-50, Ro < 200 Ohm [mA] 4...12...20, Ro < 500 Ohm |
| Output signal resolution | [%] 0.025 |
| Potentiometer supply | [V] +10...0...-10 2 %, rated max. 15 mA |
| Sensor supply | [V] 18...30 (Us), rated max. 100 mA |
| Adjustment ranges | Min [V] 0...50 Max [V] 50...100 Ramp [s] 0...32.5 Zero offset [%] +100...-100 |
| Interface | USB type B |
| EMC | EN IEC 61000-6-2, EN IEC 61000-6-4 |
| Connection | Screw terminals 0.2...2.5 mm ² , disconnectable |
| Cable specification | [mm ²] 0.5 overall braid shield (AWG20) |
| Cable length | [m] 50 |
| Technology function | Software adjustable transfer function with 10 compensation points for linearization of valve behaviour |

Dimensions

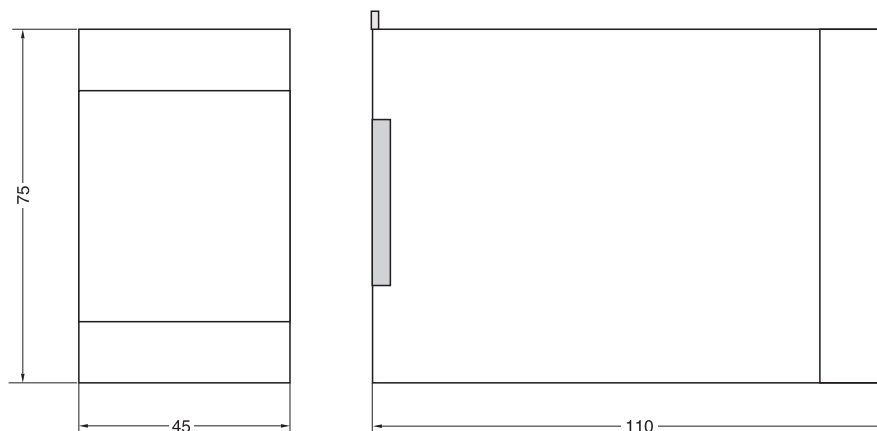

Block Diagram / Construction

Block diagram

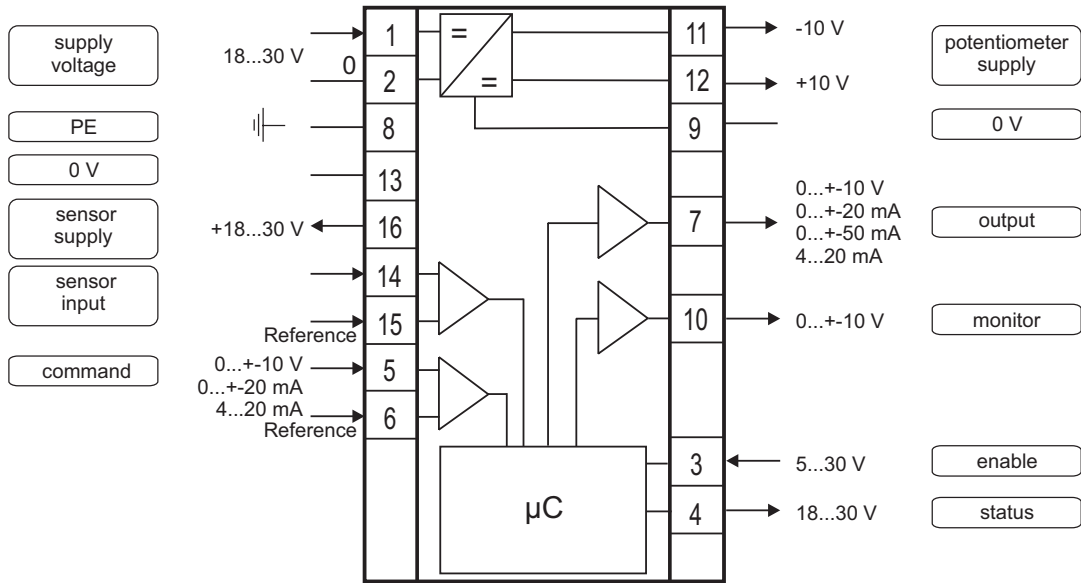

Signal flow diagram

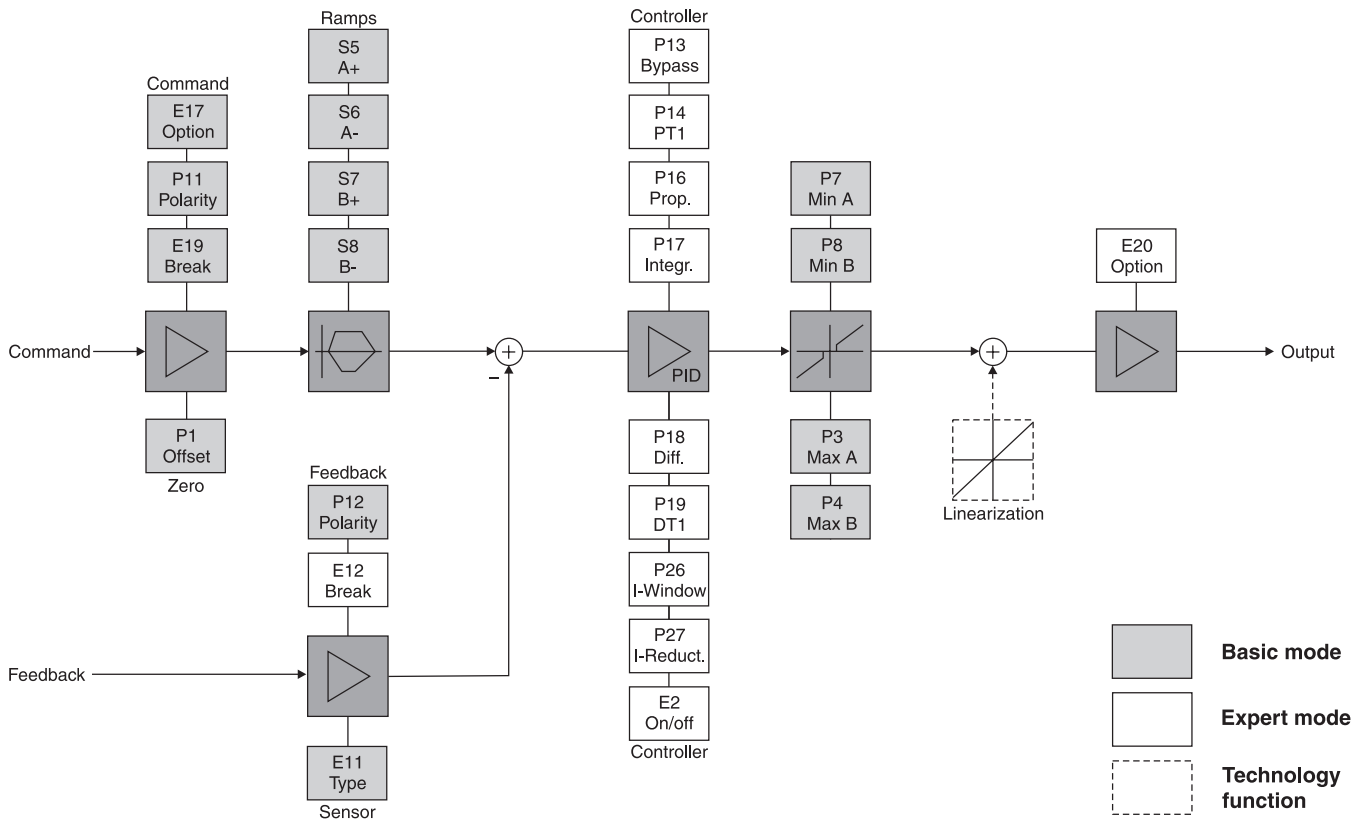

11

ProPxD interface program

The ProPxD software permits comfortable parameter setting for the module electronics. Via the clearly arranged entry mask the parameters can be monitored and modified. Storage of complete parameter sets is possible as well as printout or record as a text file for further documentation. Stored parameter sets may be loaded anytime and transmitted to other valves. Inside the electronics a nonvolatile memory stores the data with the option for recalling or modification.

The PC software can be downloaded free of charge at www.parker.com/propxd.

Features

- Comfortable editing of all parameters
- Depiction and documentation of parameter sets
- Storage and loading of optimized parameter adjustments
- Executable with all actual Windows® operating systems from Windows® XP upwards
- Plain communication between PC and electronics via USB interface

