

**Characteristics**

The pilot operated proportional directional valves D\*1FB are available in 4 sizes:

- D31FB - NG10 (CETOP 05)
- D41FB - NG16 (CETOP 07)
- D91FB - NG25 (CETOP 08)
- D111FB - NG32 (CETOP 10)

The valves are available with and without onboard electronics (OBE).

**D\*1FB OBE**

The digital onboard electronics is situated in a robust metal housing, which allows the usage under rough environmental conditions.

The nominal values are factory set. The cable connection to a serial RS232 interface is available as accessory.

**D\*1FB for external electronics**

The parameters can be saved, changed and duplicated in combination with the digital power amplifier PWD00A-400.

The valve parameters can be edited with the common ProPxD software for both versions.

The D\*1FB valves work with barometric feedback of the main stage to the pressure reducing pilot valve. The pilot control pressure of 25 bar allows high flow rates at maximum stability.

Valves with explosion proof solenoids Ex e mb II see catalogue HY11-3343.

Download: [www.parker.com/euro\\_hcd](http://www.parker.com/euro_hcd) - see "Literature"



D91FB OBE

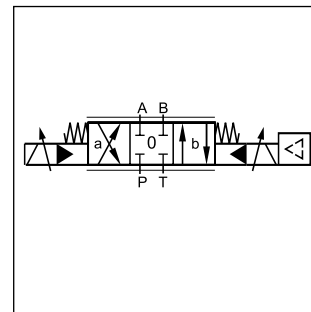

Standard D\*1FB OBE

3

**Technical Features**

- Progressive flow characteristics for sensitive adjustment of flow rate
- High flow capacity
- Digital onboard electronics optional
- Centre position monitoring optional

**D91FB OBE**

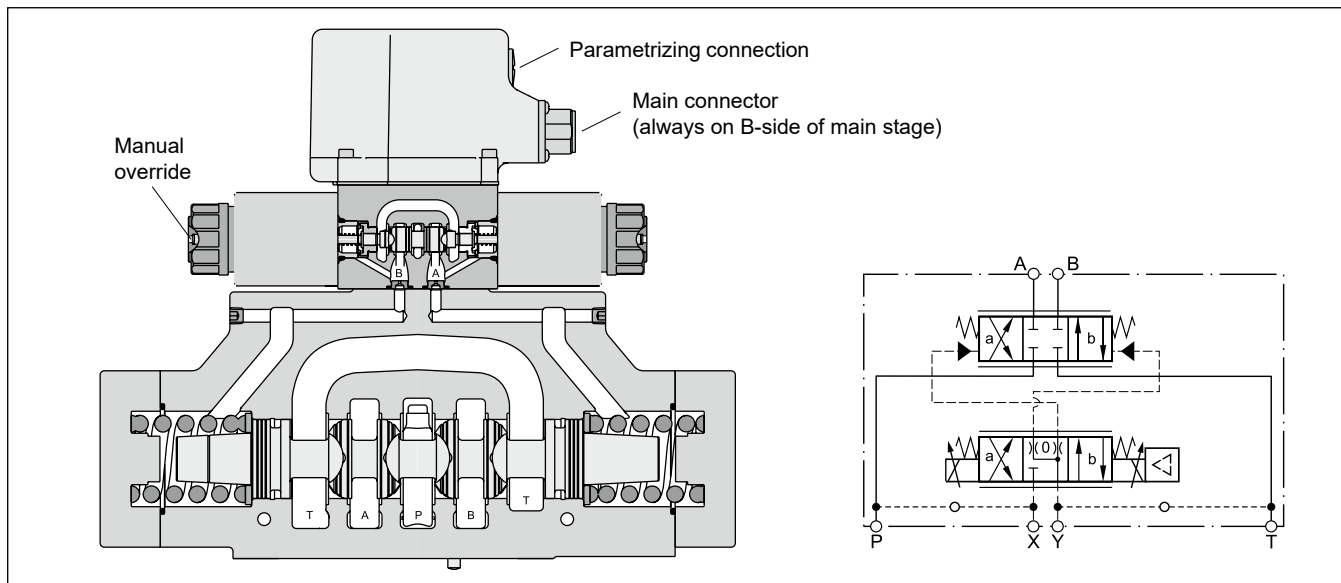

**D\*1FB**

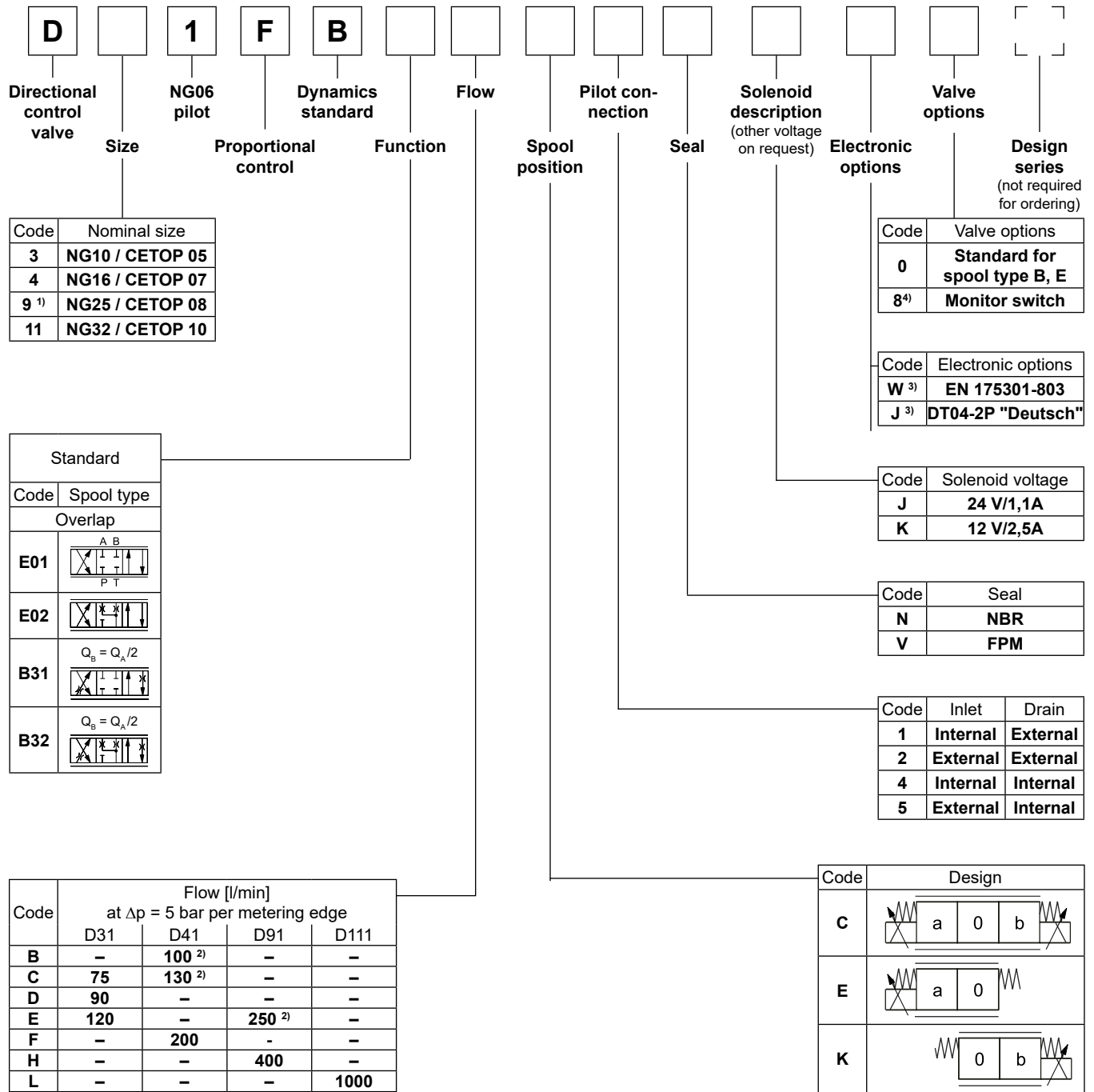

**3**

Short delivery time  
for all variations

<sup>1)</sup> With enlarged connections Ø 32 mm.  
<sup>2)</sup> Not for spool type B31 und B32.  
<sup>3)</sup> Please order plugs separately. See accessories.  
<sup>4)</sup> Please order female connector M12x1 separately (see accessories , female connector M12x1 (order no.: 5004109).

**D\*1FB OBE**

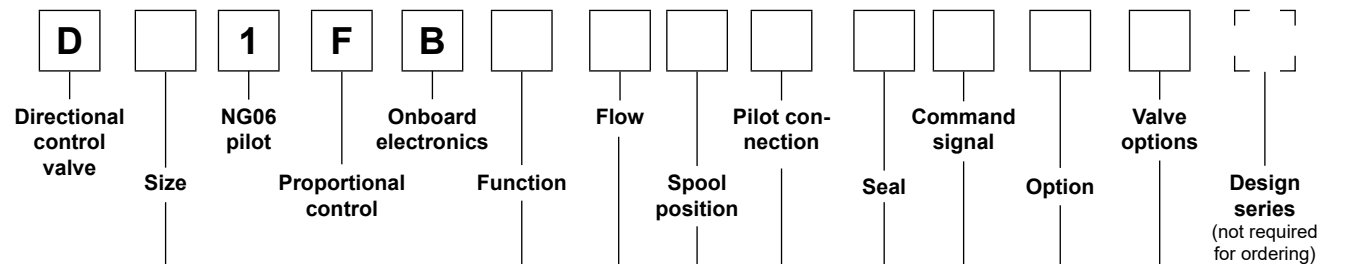

**3**

Code	Nominal size
3	NG10 / CETOP 05
4	NG16 / CETOP 07
9 <sup>1)</sup>	NG25 / CETOP 08
11	NG32 / CETOP 10

Code	Valve options
0	Standard for spool type B, E, R
8 <sup>7)</sup>	Monitor switch

Code	Spool type
Overlap	
E01	
E02	
B31	$Q_B = Q_A / 2$ 
B32	$Q_B = Q_A / 2$ 

Code	Command signal <sup>4)</sup>	Function	Connection <sup>3)</sup>
F0 <sup>6)</sup>	0...±10 V	0...+10 V > P-B	6 + PE
G0 <sup>5)</sup>	0...±20 mA	0...+20 mA > P-B	6 + PE
M0 <sup>5) 6)</sup>	0...±10 V	0...+10 V > P-A	6 + PE
S0	4...20 mA	12...20 mA > P-A	6 + PE
W5 <sup>5) 6)</sup>	0...±10 V 4...20 mA	0...+10 V > P-A 12...20 mA > P-A	11 + PE

Code	Seal
N	NBR
V	FPM

Code	Flow [l/min] at Δp = 5 bar per metering edge			
	D31	D41	D91	D111
B	-	100 <sup>2)</sup>	-	-
C	75	130 <sup>2)</sup>	-	-
D	90	-	-	-
E	120	-	250 <sup>2)</sup>	-
F	-	200	-	-
H	-	-	400	-
L	-	-	-	1000

Code	Inlet	Drain
1	Internal	External
2	External	External
4	Internal	Internal
5	External	Internal

Code	Design
C	
E	
K	

Parametrizing cable OBE®  
 RS232, item no. 40982923

Short delivery time  
 for all variations

<sup>1)</sup> With enlarged connections Ø 32 mm.  
<sup>2)</sup> Not for spool type B31 und B32.  
<sup>3)</sup> Please order plugs separately, see accessories.  
<sup>4)</sup> For 1 solenoid 0...+10 V respectively 4...20 mA.  
<sup>5)</sup> Not for spool position E and K.  
<sup>6)</sup> F0, M0 potentiometer supply, W5 command channel & potentiometer supply.  
<sup>7)</sup> Please order female connector M12x1 separately (see accessories , female connector M12x1 (order no.: 5004109)

<b>General</b>					
Design	Pilot operated DC valve				
Actuation	Proportional solenoid				
Size	<b>NG10 (CETOP 05)</b>	<b>NG16 (CETOP 07)</b>	<b>NG25 (CETOP 08)</b>	<b>NG32 (CETOP 10)</b>	
Mounting interface	DIN 24340 / ISO 4401 / CETOP RP121 / NFPA				
Mounting position	unrestricted				
Ambient temperature	-20...+60				
MTTF <sub>D</sub> value <sup>1)</sup>	[years]	75			
Weight (OBE)	[kg]	8.6 (9.3)	11.9 (12.6)	20.4 (21.1)	68 (68.7)
<b>Hydraulic</b>					
Max. operating pressure	[bar]	Pilot drain internal: P, A, B, X 350; T, Y 185			
Fluid	[bar]	Pilot drain external: P, A, B, T, X 350; Y 185			
Fluid temperature	[°C]	Hydraulic oil according to DIN 51524 ... 535, other on request			
Viscosity permitted	[cSt] / [mm <sup>2</sup> /s]	-20...+60 (NBR: -25...+60)			
Viscosity recommended	[cSt] / [mm <sup>2</sup> /s]	20...400			
Filtration		30...80			
Nominal flow		ISO 4406; 18/16/13			
at Δp=5 bar per control edge <sup>2)</sup>	[l/min]	75/90/120	130/200	250/400	1000
Max. recommended flow	[l/min]	170	420	700	2000
Leakage at 100 bar	[ml/min]	100	200	600	1000
Opening point (OBE)	[%]	see flow characteristics (set to 10 command signal)			
Pilot supply pressure	[bar]	min. 30 (+ T/Y pressure)			
Pilot flow at 100 bar	[l/min]	max. 350			
Pilot flow, step response	[l/min]	optimal dynamics at 50			
		<0.5	<1.2	<1.2	<1.2
		2.0	1.9	4.5	18
<b>Static / Dynamic</b>					
Step response at 100 % step	[ms]	50	75	100	180
Hysteresis	[%]	<5			
<b>Electrical characteristics</b>					
Duty ratio	[%]	100 ED; CAUTION: Coil temperature up to 150 °C possible			
Protection class		Standard (as per EN175301-803) IP65 in accordance with EN 60529			
Solenoid	Code	DT04-2P "Deutsch" IP69K (with correctly mounted plug-in connector)			
Supply voltage	[V]	K		J	
Current consumption	[A]	12		24	
Resistance	[Ohm]	2.5		1.1	
		4.4		18.6	
Solenoid connection		Connector as per EN 175301-803 (code W),			
Wiring min.	[mm <sup>2</sup> ]	DT04-2P "Deutsch" connector (code J). Solenoid identification as per ISO 9461.			
Wiring length max.	[m]	3x1.5 (AWG 16) overall braid shield			
		50			

**3**

<sup>1)</sup> If valves with onboard electronics are used in safety-related parts of control systems, in case the safety function is requested, the valve electronics voltage supply is to be switched off by a suitable switching element with sufficient reliability.

<sup>2)</sup> Flow rate for different Δp per control edge:

$$Q_x = Q_{Nom.} \cdot \sqrt{\frac{\Delta p_x}{\Delta p_{Nom.}}}$$

<b>Electrical characteristics (D*1FB OBE)</b>			
Vibration resistance	[g]		10 Sinus 5...2000 Hz acc. IEC 68-2-6 10 (RMS) Random noise 20...2000 Hz acc. IEC 68-2-36 15 Shock acc. IEC 68-2-27
Duty ratio	[%]		100 ED; CAUTION: coil temperature up to 150 °C possible
Protection class			IP65 in accordance with EN 60529 (with correctly mounted plug-in connector)
Supply voltage/ripple DC	[V]		18...30, ripple < 5 % eff., surge free
Current consumption max.	[A]		2.0
Pre fusing medium lag	[A]		2.5
Input signal			
Codes F0, M0, W5 voltage	[V]		+10...0...-10, ripple < 0.01 % eff., surge free, Ri = 100 kOhm
Code G0 current	[mA]		+20...0...-20, ripple < 0.01 % eff., surge free, Ri = <250 Ohm
Codes S0 & W5 current	[mA]		4...12...20, ripple < 0.01 % eff., surge free, Ri = <250 Ohm < 3.6 mA = enable off, > 3.8 mA = enable on (acc. to NAMUR NE43)
Differential input max.			
Codes F0, M0 G0 & S0	[V]		30 for terminal D and E against PE (terminal G) 11 for terminal D and E against 0V (terminal B)
Code W5	[V]		30 for terminal 4 and 5 against PE (terminal PE) 11 for terminal 4 and 5 against 0V (terminal 2)
Channel recall signal	[V]		0...2.5: off / 5...30: on / Ri = 100 kOhm
Adjustment ranges			
Min	[%]		0...50
Max	[%]		50...100
Ramp	[s]		0...32.5
Interface			RS 232, parametrizing connection 5pole
EMC			EN 61000-6-2, EN 61000-6-4
Central connection			
Codes F0, M0 G0 & S0			6 + PE acc. to EN 175201-804
Code W5			11 + PE acc. to EN 175201-804
Wiring min.			
Codes F0, M0 G0 & S0	[mm <sup>2</sup> ]		7 x 1.0 (AWG16) overall braid shield
Code W5	[mm <sup>2</sup> ]		11 x 1.0 (AWG16) overall braid shield
Wiring length max.			50

With electrical connections the protective conductor (PE ⚡) must be connected according to the relevant regulations.

**D\*1FB B/E Flow characteristics**  
 at  $\Delta p = 5$  bar per metering edge  
 Spool code **E01/02**

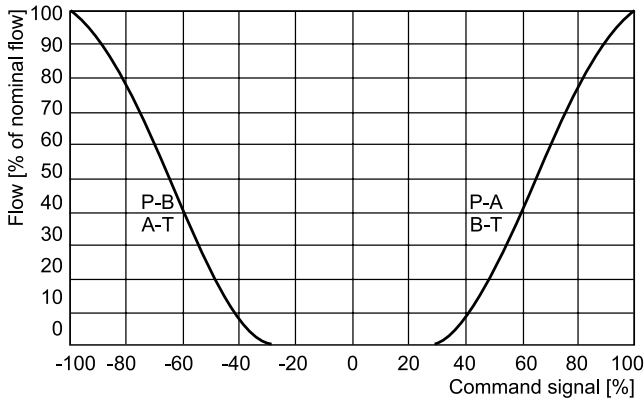

Spool code **B31/32\***

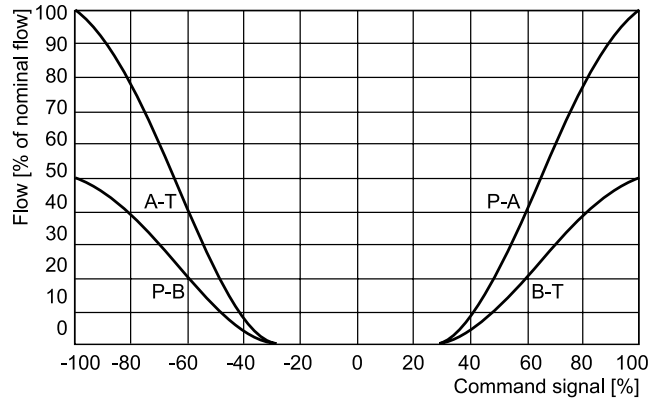

**D\*1FB B/E OBE**  
**Flow characteristics**  
 (set to opening point 10 %)  
 at  $\Delta p = 5$  bar per metering edge

Spool code **E01/02**

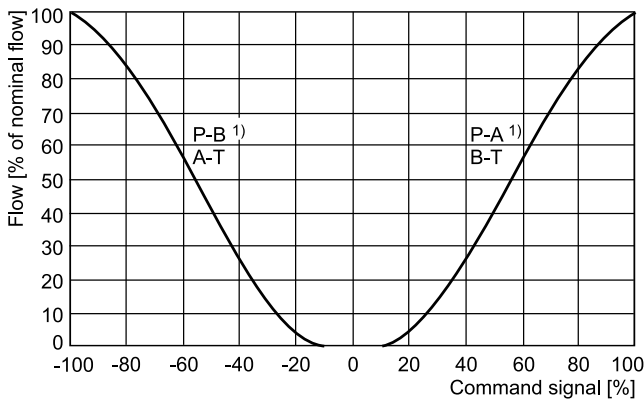

Spool code **B31/32**

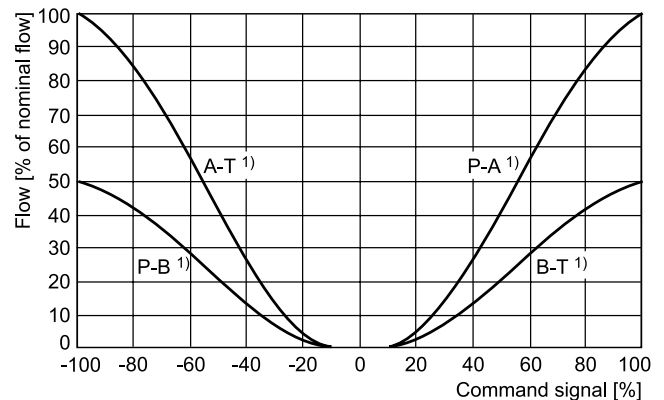

All characteristic curves measured with HLP46 at 50 °C.

<sup>1)</sup> Flow direction depending on ordering code.

**Electrical characteristics of position control M12x1 as per IEC 61076-2-101**

Supply voltage	[VDC]	24
Tolerance supply voltage	[%]	±20
Ripple supply voltage	[%]	≤10
Polarity protection	[V]	300
Current consumption without load	[mA]	≤20
Switching hysteresis	[mm]	<0.06
Max. output current per channel, ohmic	[mA]	250
Ambient temperature	[°C]	-20 ... +60
Protection		IP65 acc. EN 60529
CE conform		EN 61000-4-2 / EN 61000-4-4 / EN 61000-4-6 <sup>1)</sup> / ENV 50140 / ENV 50204
Min. distance to next AC solenoid	[m]	0.1
Interface		M12x1 to IEC 61076-2-101

3

**M12 pin assignment**

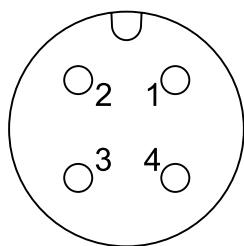

- 1 + U<sub>s</sub> 19.2...28.8 V
- 2 Out B: normally open
- 3 0V
- 4 Out A: normally closed

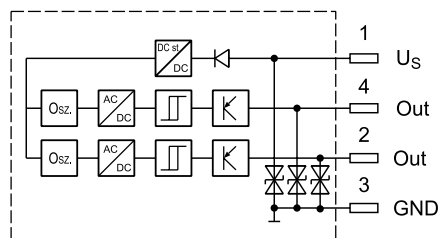

Outputs: Open collector

Signal	Output A (pin 4)	Output B (pin 2)
neutral	closed	closed
	open	closed
	closed	open

The neutral position is monitored. The signal changes after less than 10 % of the spool stroke.

Please order female connector M12x1 separately (see accessories, female connector M12x1 (order no.: 5004109)).

<sup>1)</sup> Only guaranteed with screened cable and female connector

Code F0, M0  
 6 + PE acc. to EN 175201-804

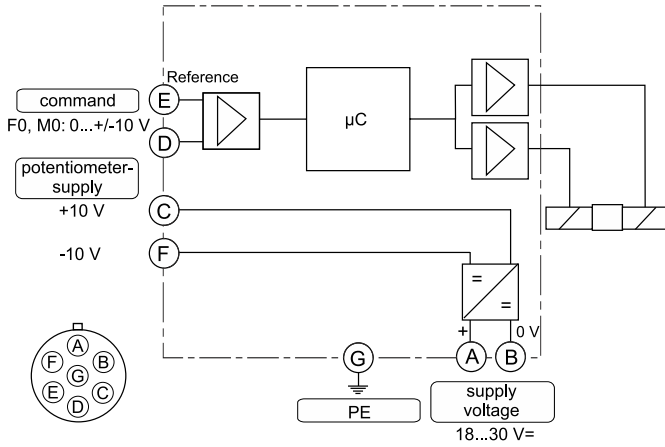

Code G0, S0  
 6 + PE acc. to EN 175201-804

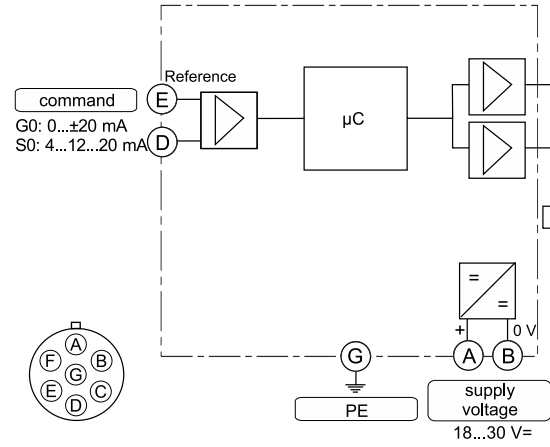

**3**

Code W5  
 11 + PE acc. to EN 175201-804

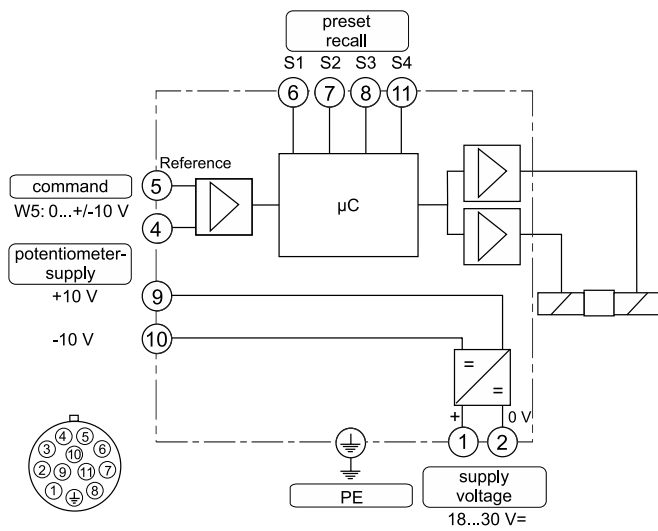

**ProPxD interface program**

The ProPxD software permits comfortable parameter setting for the module electronics. Via the clearly arranged entry mask the parameters can be noticed and modified. Storage of complete parameter sets is possible as well as printout or record as a text file for further documentation. Stored parameter sets may be loaded anytime and transmitted to other valves. Inside the electronics a non-volatile memory stores the data with the option for recalling or modification.

The PC software can be downloaded free of charge at [www.parker.com/isde](http://www.parker.com/isde) – see page "Support" or directly at [www.parker.com/propxd](http://www.parker.com/propxd).

**Features**

- Comfortable editing of all parameters
- Depiction and documentation of parameter sets
- Storage and loading of optimized parameter adjustments
- Executable with all actual Windows® operating systems from Windows® XP upwards
- Plain communication between PC and electronics via serial interface RS232C

**The parametrizing cable may be ordered under item no. 40982923.**

3

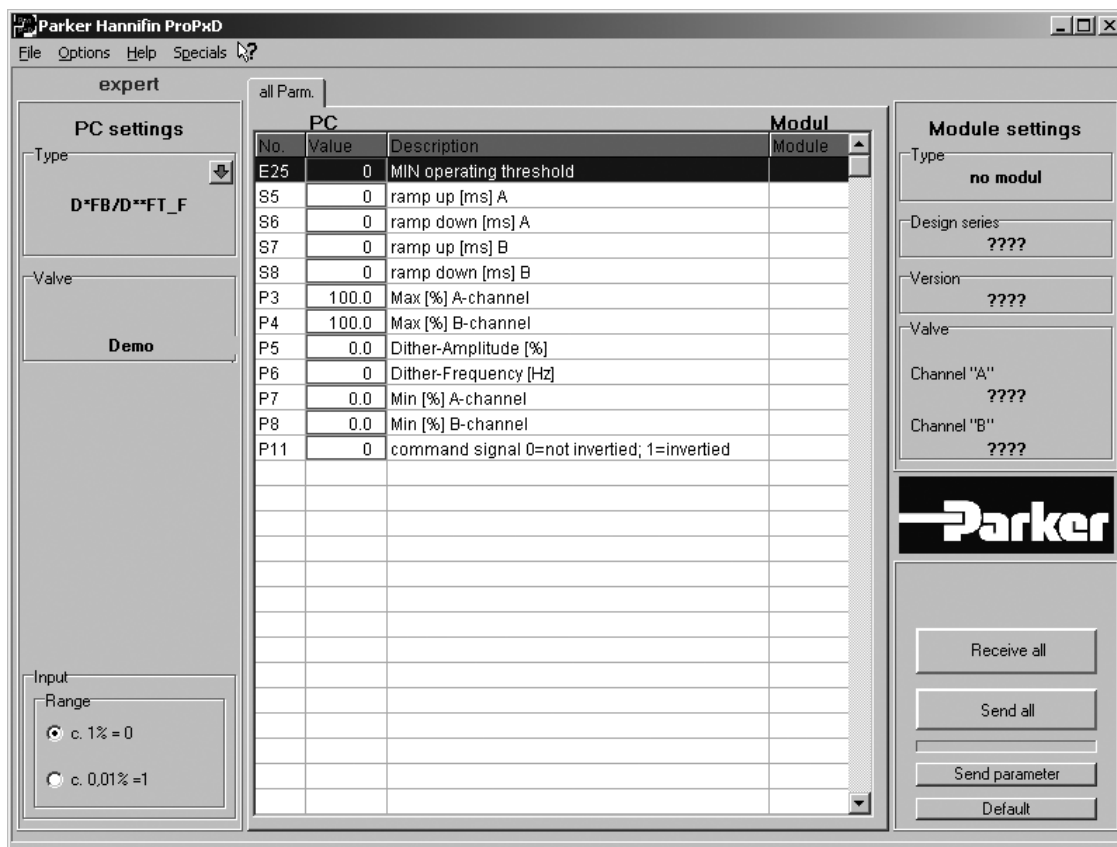

**Pilot oil inlet (supply) and outlet (drain)**

○ open, ● closed

Pilot oil		B	C
Inlet	Drain		
internal	external	○	●
external	external	●	●
internal	internal	○	○
external	internal	●	○

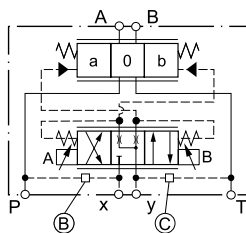

**D31FBB/E**

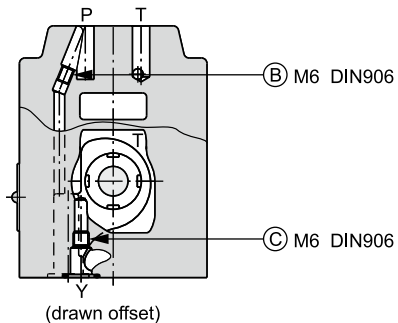

**D41FBB/E**

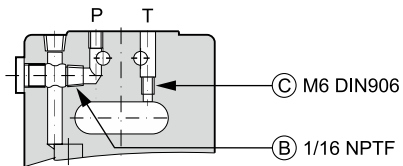

**D91FBB/E**

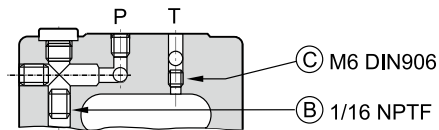

**D111FBB/E**

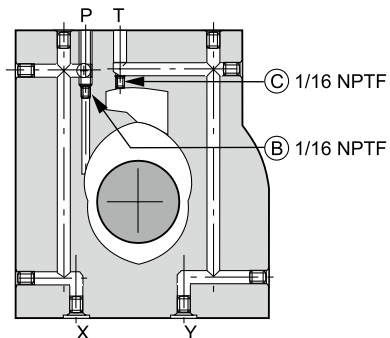





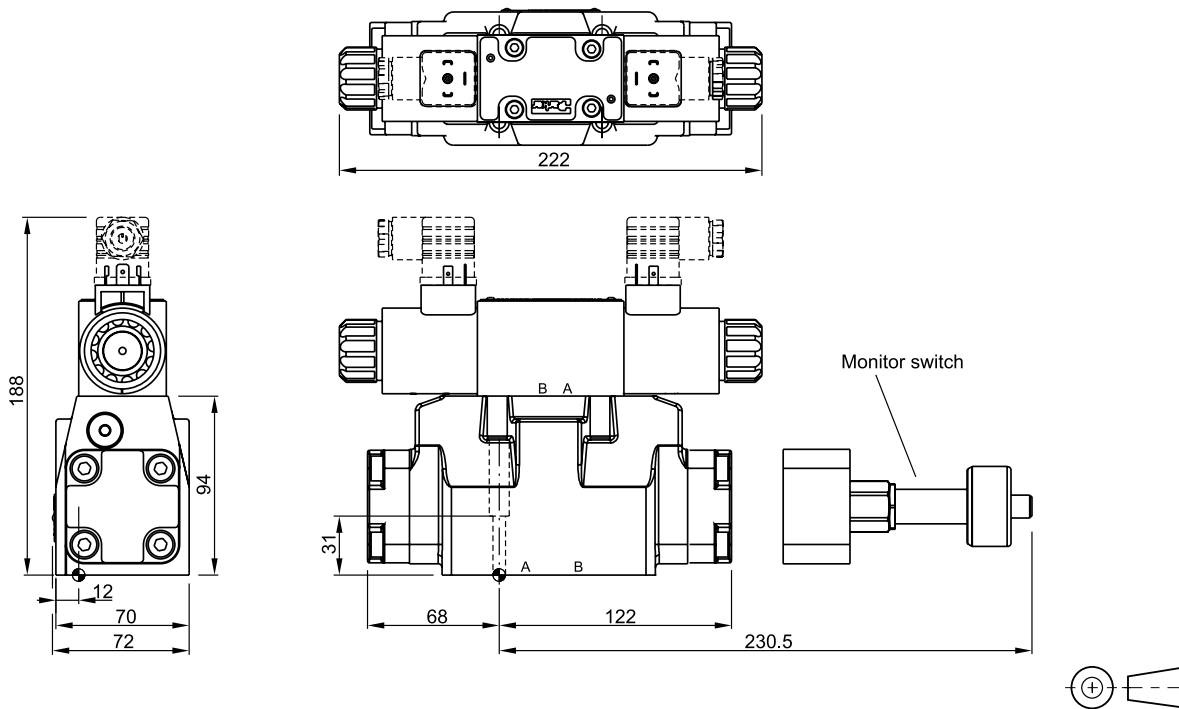

D\_1FB UK.indd 25.03.24

**3**

**D31FB**





3

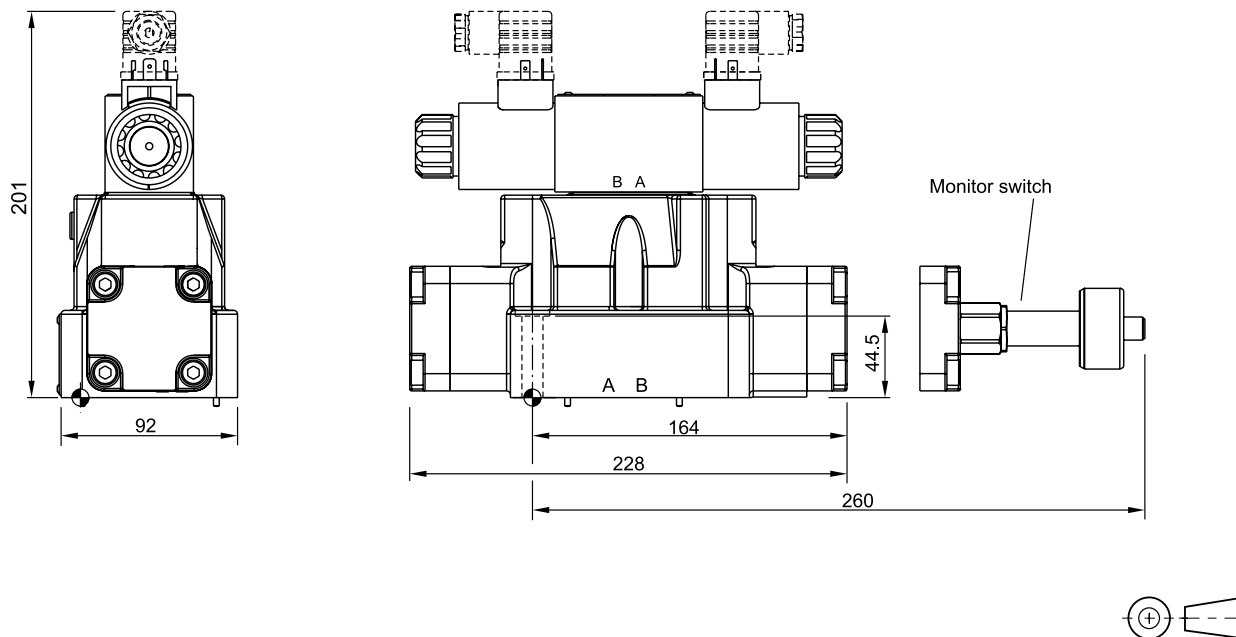

Surface finish	 Kit	 Kit	 Kit	 Kit
$\sqrt{R_{max}6.3}$ 	BK385	4x M6x40 ISO 4762-12.9	13.2 Nm ±15 %	NBR: SK-D31FB FPM: SK-D31FB-V



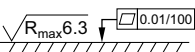

**D41FB**

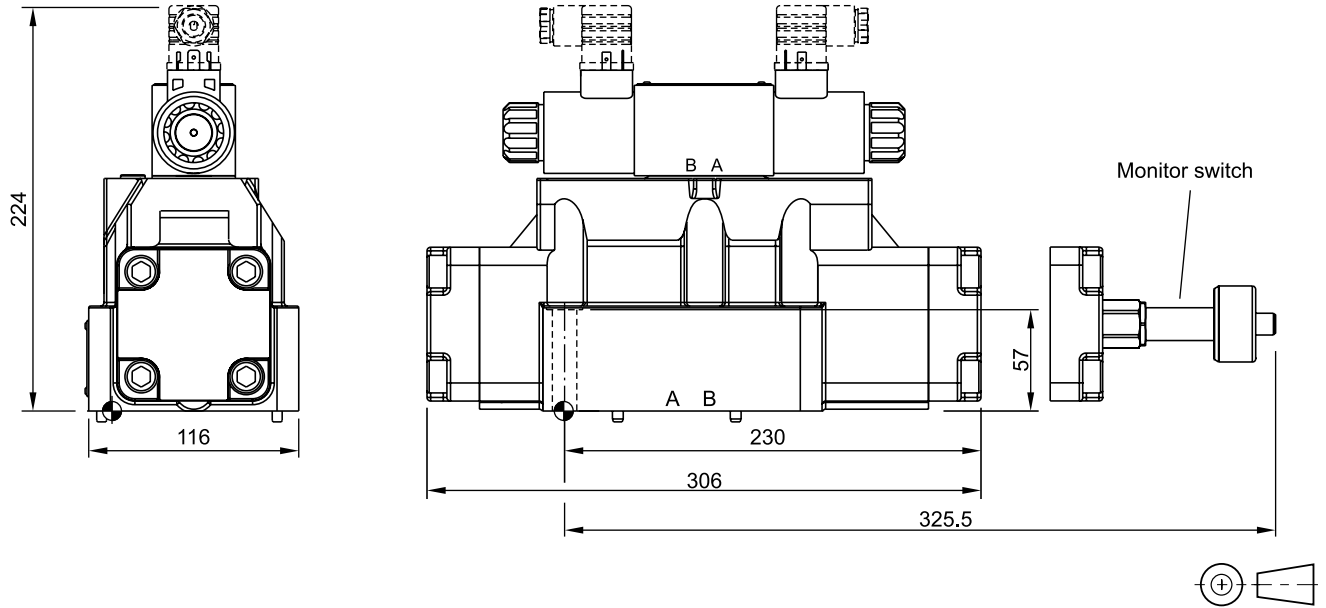

Surface finish	 Kit	 Kit	 Kit	 Kit
$\sqrt{R_{max}6.3}$ 	BK320	2x M6x55 4x M10x60 ISO 4762-12.9	13.2 Nm ±15 % 63 Nm ±15 %	NBR: SK-D41FB FPM: SK-D41FB-V



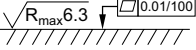

**D91FB**

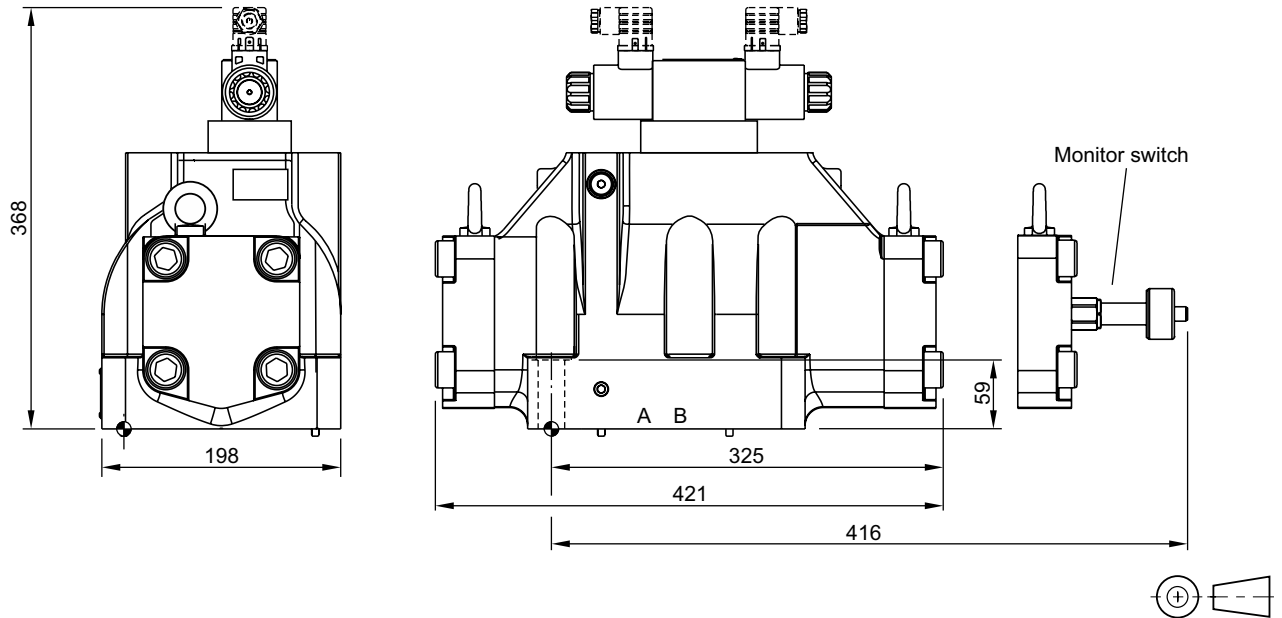

Surface finish	 Kit			 Kit
	BK360	6x M12x75 ISO 4762-12.9	108 Nm ±15 %	NBR: SK-D91FB FPM: SK-D91FB-V

**D111FB**

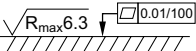

Surface finish	 Kit			 Kit
	BK386	6x M20x90 ISO 4762-12.9	517 Nm ±15 %	NBR: SK-D111FB FPM: SK-D111FB-V

**Dimensions**

**Dimension with DT04-2P "Deutsch" Connector**

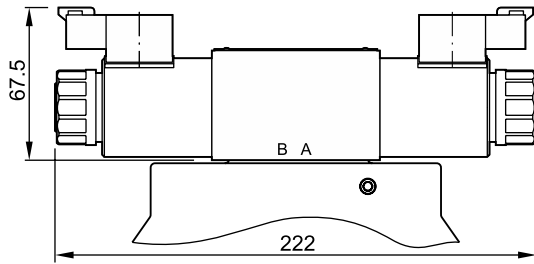

3

**D31FB OBE**

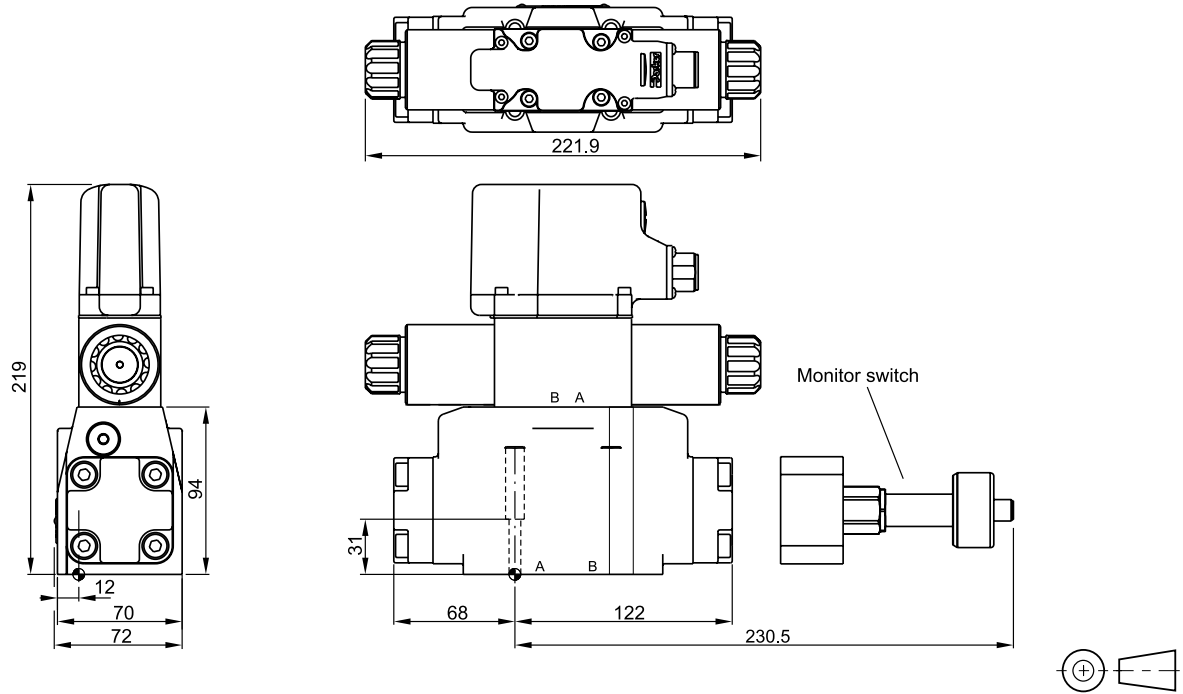

Surface finish	Kit	Kit	Kit	Kit
	BK385	4x M6x40 ISO 4762-12.9	13.2 Nm ±15 %	NBR: SK-D31FB FPM: SK-D31FB-V



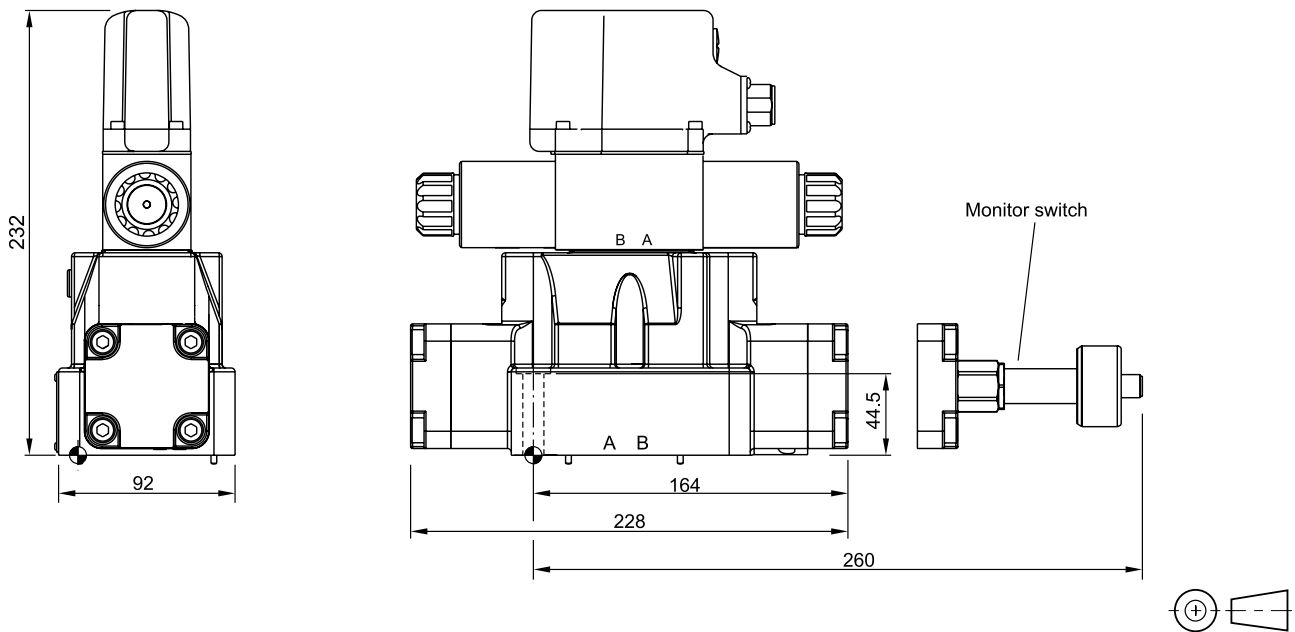

**D41FB OBE**

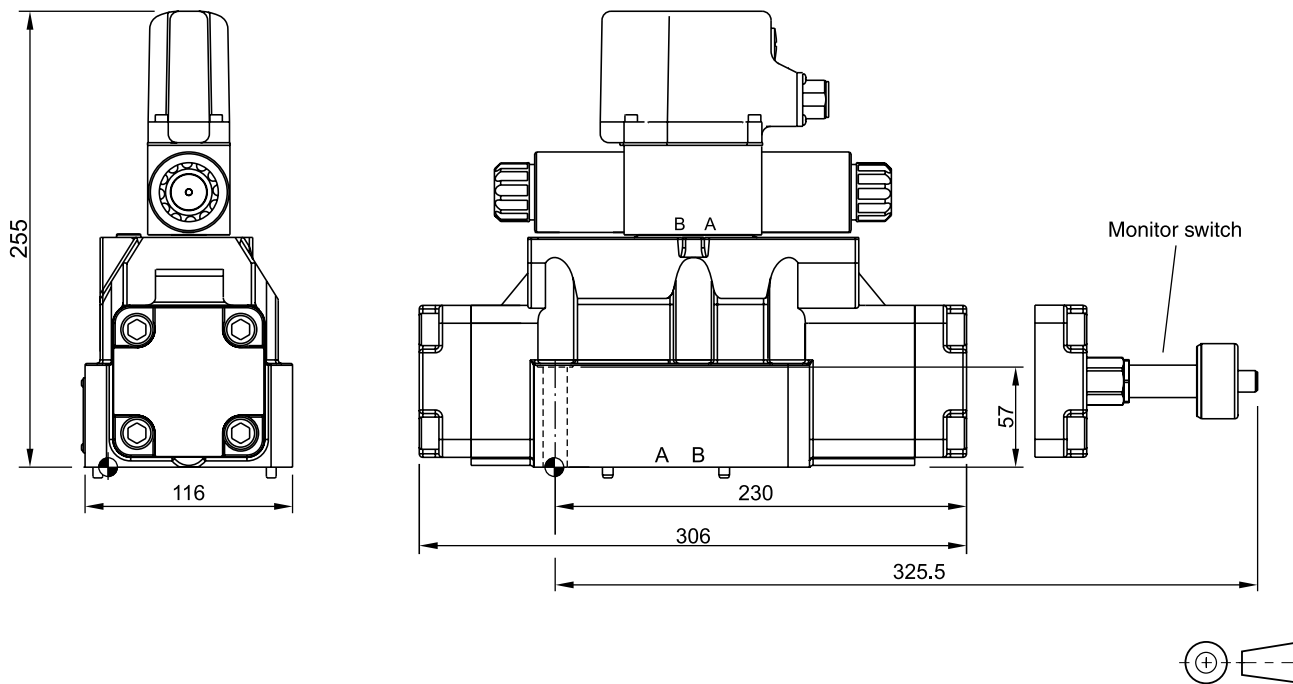

Surface finish	Kit	Kit	Kit	Kit
	BK320	2x M6x55 4x M10x60 ISO 4762-12.9	13.2 Nm ±15 % 63 Nm ±15 %	NBR: SK-D41FB FPM: SK-D41FB-V



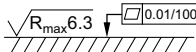

**D91FB OBE**

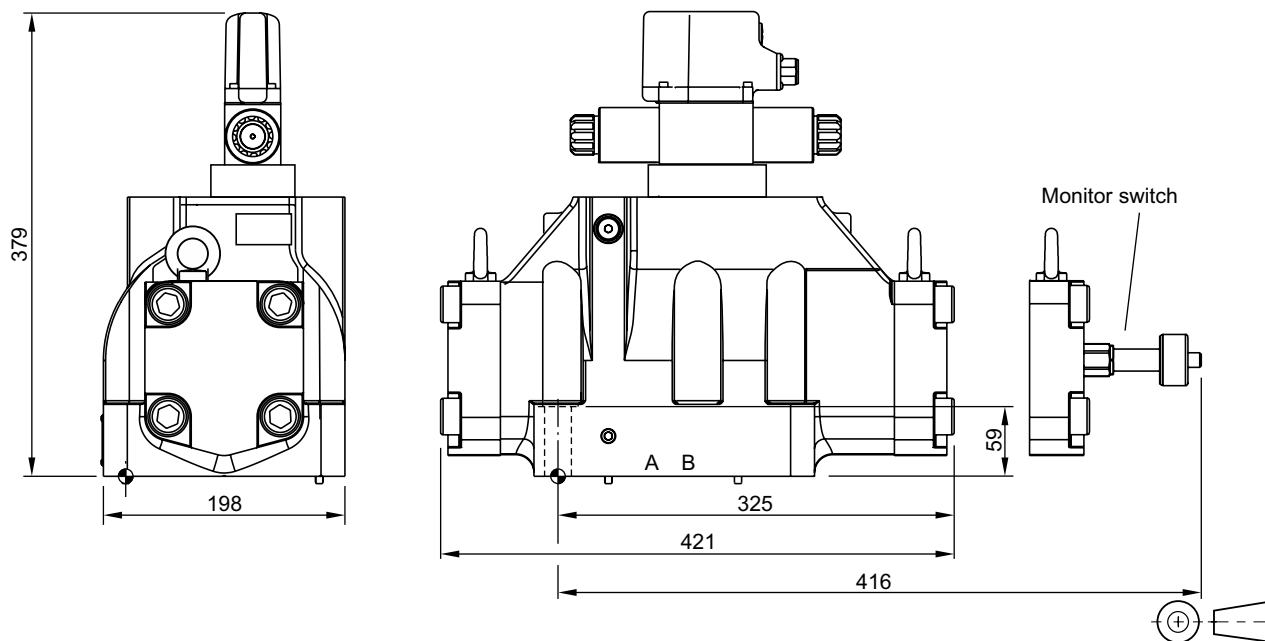

Surface finish	 Kit	 Kit	 Kit	 Kit
	BK360	6x M12x75 ISO 4762-12.9	108 Nm ±15 %	NBR: SK-D91FB FPM: SK-D91FB-V

**D111FB OBE**

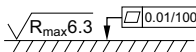

Surface finish	 Kit	 Kit	 Kit	 Kit
	BK386	6x M20x90 ISO 4762-12.9	517 Nm ±15 %	NBR: SK-D111FB FPM: SK-D111FB-V