

Characteristics

Seat valves series D4S are designed for directional control functions. A large variety of poppets, springs and covers – including shuttle valves, stroke limiters, solenoid valves (VV01) and position control – allow to design individual hydraulic solutions for nominal flow up to 600 l/min.

A complete program of 2/2-way seat valves is offered under Parker brand:

- subplate mounted valves series D4S chapter 6
- SAE flange valves series D5S chapter 9
- slip-in cartridges series CAR on request

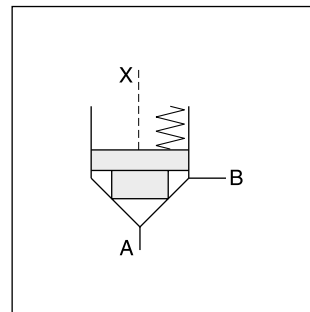

Features

- Subplate mounting according to ISO 5781
- Leak-free seat valve design
- Numerous pilot options
- 6 poppet types
- D4S03 - NG10
- D4S06 - NG25
- D4S10 - NG32

6

D4S10-9DC

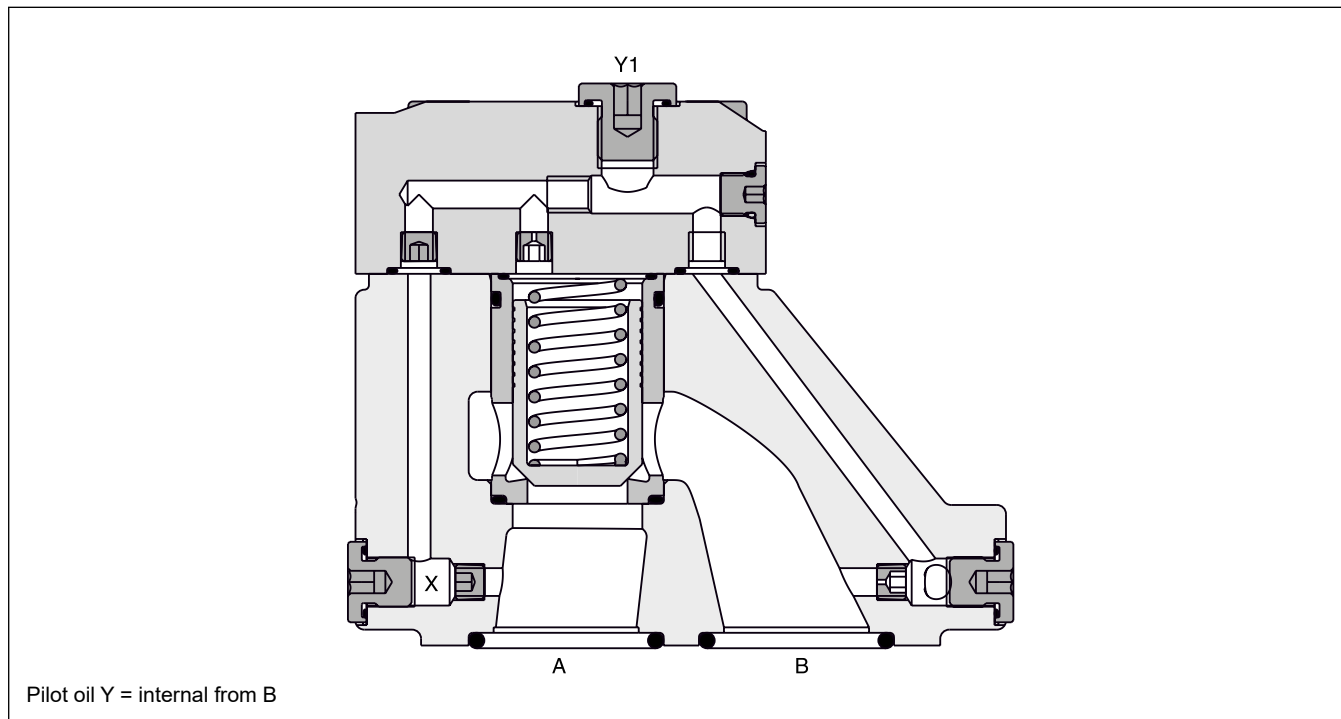

Pilot oil Y = internal from B

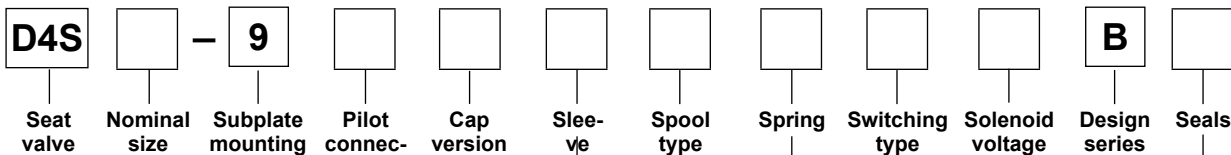

Code	Nominal size
03	NG10
06	NG25
10	NG32

Code	Pilot oil line in body	A-X B-Y	
		A-X	B-Y
1	internal from A	●	○
2	external from X	●	○
A ¹⁾	internal from A	●	●
B	external from X	●	●
C	internal from A + B	●	●
D	internal from B	●	●
G	external from Y	●	●

Code	Ports	X	Y	Z	X-Y	Y1	VV01
Standard							
1	Pilot oil = pilot drain	○	●	●	○	●	—
C	Pilot oil = pilot drain	●	○	●	○	●	—
With solenoid valve (VV01)							
2	Ext. PD from cap	○	○	●	●	○	●
5	Ext. to subplate	○	○	●	●	●	○
6	Internal pilot drain	○	○	●	●	●	○
With stroke limiter (not for D4S03)							
3	Pilot oil = pilot drain	●	●	—	—	—	—
4	Pilot oil = pilot drain	●	●	—	—	—	—

○ open bore ● closed bore ◐ orifice Ø 1.2

Code	Sleeve
1	AA = 95 %, AB = 5 %
3	AA = 60 %, AB = 40 %

Code	Size	Poppet type	Sleeve
1	03, 06, 10	With closed bottom and 15° chamfer (pZ max. = pA +20 bar)	1
2	03	With 0.8 dia. orifice at the bottom and 15° chamfer	1
	06, 10	With 1.2 dia. orifice at the bottom and 15° chamfer	1
4	03, 06, 10	With closed bottom and 45° chamfer	1, 3
A ²⁾	06, 10	Safety spool (for position control only)	3
B ²⁾	06, 10	Throttle spool, 10° chamfer	3
C ²⁾	06, 10	Throttle spool, 3° chamfer	3

Code	Spring (approx. cracking pressure [bar])					
	Sleeve Code 1		Sleeve Code 3			
	A → B	A → B	A → B	B → A	B → A	B → A
	D4S03	D4S06/10	D4S03	D4S06/10	D4S03	D4S06/10
1	2.8	3.5	6.5	6.5	9.5	11.0
2	0.5	0.5	1.0	1.0	1.5	1.7
3	0.3	0.3	0.6	0.6	0.9	1.0
4	2.2	2.2	4.0	3.5	5.5	6.0
5	—	9.0	—	16.0	—	28.0
6	1.2	1.2	2.0	2.2	3.0	3.8
7	3.0	—	8.0	—	12.0	—

Code	Seals
1	NBR
5	FPM

Code	Solenoid voltage
omit	Standard w/o vent function
G0R	12 V=
G0Q	24 V=
GAR ⁴⁾	98 V=
GAG ⁴⁾	205 V=
W30	110 V / 50 Hz 120 V / 60 Hz
W31	230 V / 50 Hz 240 V / 60 Hz

Code	Switching type	
omit	Standard w/o vent function	
09	VV01 with manual override	de-energized: power comp. open
10	VV01 without manual override	
11	VV01 with manual override	de-energized: power comp. closed
12	VV01 without manual override	
CA	Shuttle valve	
DA	Shuttle valve	
CB	VV01 code 09 and shuttle valve code CA	
CD	VV01 code 11 and shuttle valve code CA	
DB	VV01 code 09 and shuttle valve code DA	
DD	VV01 code 11 and shuttle valve code DA	
EH	VV01 code 10 and shuttle valve code CA and position control ³⁾ with amplifier	
EK	VV01 code 12 and shuttle valve code CA and position control ³⁾ with amplifier	
EN	VV01 code 10 and shuttle valve code DA and position control ³⁾ with amplifier	
EQ	VV01 code 12 and shuttle valve code DA and position control ³⁾ with amplifier	
EC	VV01 code 10 and position control ³⁾ with amplifier	
EE	VV01 code 12 and position control ³⁾ with amplifier	
EA	Position control ³⁾ with amplifier	
EF	Position control ³⁾ with amplifier and shuttle valve code CA	
EL	Position control ³⁾ with amplifier and shuttle valve code DA	

- 1) With VV01 only.
- 2) Springs 2, 3 and 6 only.
- 3) Position control for D4S06/10 only. Spring 2 or 4. Spool A and sleeve 3. Valve open: proximity switch damped.
- 4) To be used in combination with rectifier plugs at 120 VAC/230 VAC power supply.

Examples see end of chapter

Technical Data

General		NG10			NG25		NG32	
Size		NG10			NG25		NG32	
Mounting interface		Subplate mounting according to ISO 5781						
Mounting position		unrestricted						
Ambient temperature	[°C]	-20...+60						
MTTF _D value	[years]	150						
Weight	[kg]	2.7		4.5		6.0		
Hydraulic								
Operating pressure	[bar]	Ports A, B up to 350; Port Y 140 (with VV01)						
Nominal flow	[l/min]	180		360		600		
Fluid		Hydraulic oil according to DIN 51524						
Fluid temperature	[°C]	-20...+70 (NBR: -25...+70)						
Viscosity, permitted	[cSt] / [mm ² /s]	20...400						
Viscosity, recommended	[cSt] / [mm ² /s]	30...80						
Filtration		ISO 4406; 18/16/13						
Electrical (solenoid)								
Duty ratio		100 % ED; CAUTION: coil temperature up to 150 °C possible						
Protection class		IP65 in accordance with EN 60529 (with correctly mounted plug-in connector)						
Code		G0R	G0Q	GAR	GAG	W30	W31	
Supply voltage	[V]	12 V =	24 V =	98 V =	205 V =	110 at 50 Hz 120 at 60 Hz	230 at 50 Hz 240 at 60 Hz	
Tolerance supply voltage	[%]	±10	±10	±10	±10	±5	±5	
Current consumption	[A]	2.72	1.29	0.33	0.13	0.6 / 0.55	0.3 / 0.27	
	in rush	2.72	1.29	0.33	0.13	2.5 / 2.4	1.25 / 1.2	
Power consumption	[W]	32.7	31	31.9	28.2	70 / 70 VA	70 / 70 VA	
	in rush	32.7	31	31.9	28.2	280 / 290 VA	280 / 290 VA	
Solenoid connection		Connector as per EN175301-803, solenoid identification as per ISO 9461						
Wiring min.	[mm ²]	3 x 1.5 recommended						
Wiring length max.	[m]	50 recommended						

6

D4S pilot configuration

D4S direct operated	D4S with vent valve VV01	VV01
		<p>de-energized open</p> <p>de-energized closed</p>

Δp/Q performance curves

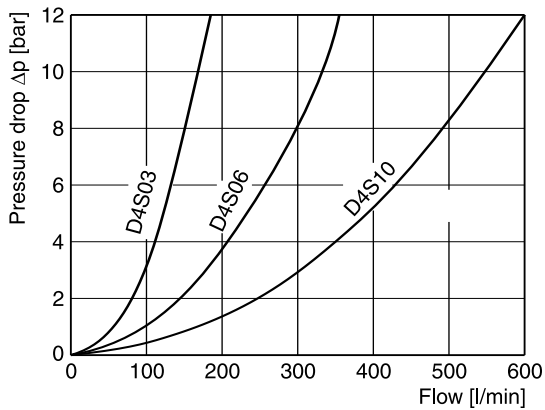

Leakage

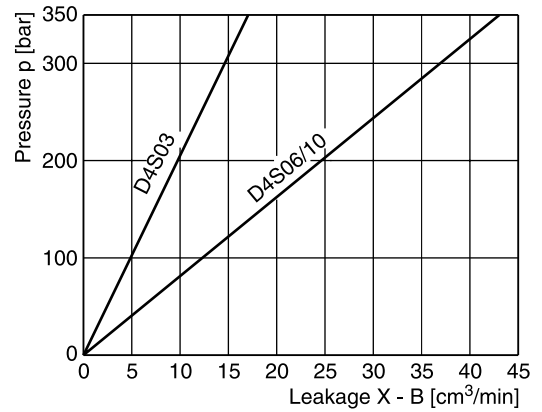

All characteristic curves measured with HLP46 at 50 °C.

Selection of Cartridges

Sleeve 1, poppet 1	Sleeve 1, poppet 2	Sleeve 1, poppet 4	Sleeve 3, poppet 4	Sleeve 3, poppet A	Sleeve 3, poppet B/C
1 : 1.05 A _A = 0.95 A _C A _B = 0.05 A _C 15° chamfer	1 : 1.05 A _A = 0.95 A _C A _B = 0.05 A _C 15° chamfer orifice	1 : 1.05 A _A = 0.95 A _C A _B = 0.05 A _C 45° chamfer	1 : 1.67 A _A = 0.6 A _C A _B = 0.4 A _C 45° chamfer	1 : 1.67 A _A = 0.6 A _C A _B = 0.4 A _C 45° chamfer safety spool	1 : 1.67 A _A = 0.6 A _C A _B = 0.4 A _C 45° chamfer throttle spool

6

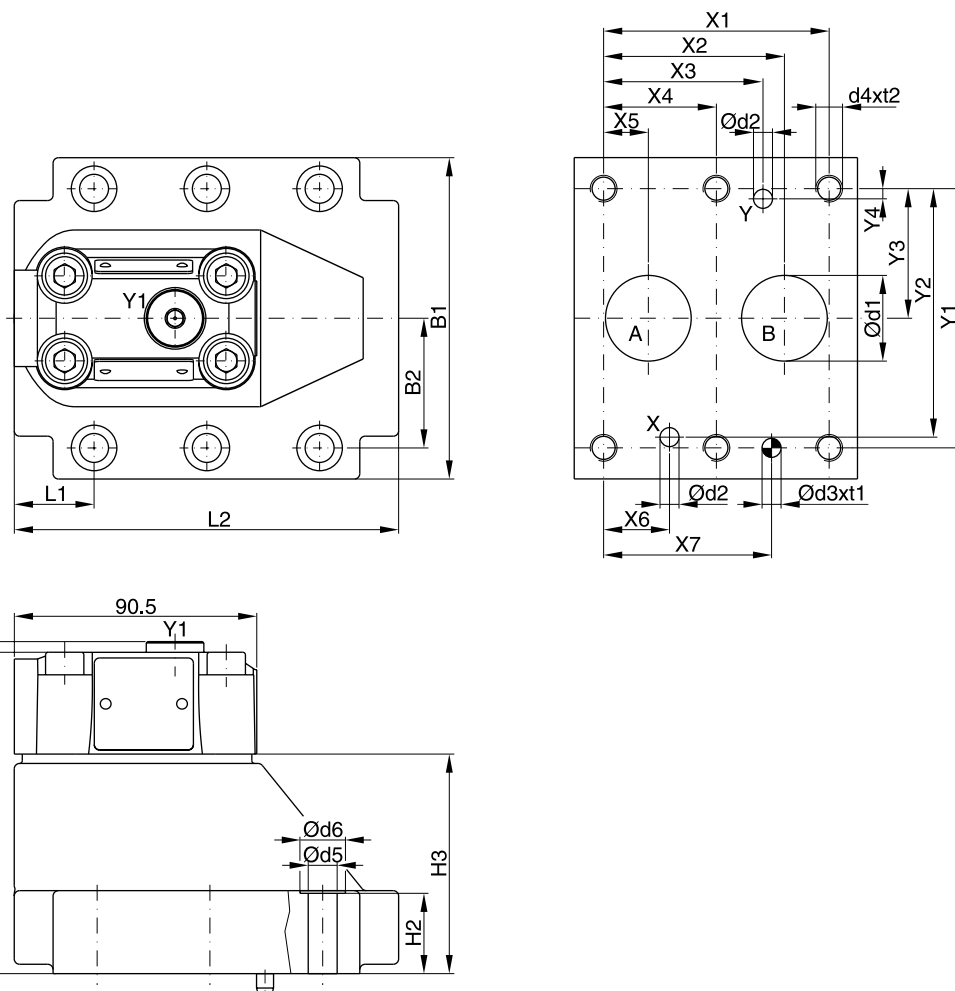

Dimensions



6

NG	ISO-code	X1	X2	X3	X4	X5	X6	X7	Y1	Y2	Y3	Y4
10	5781-06-07-0-00	42.9	35.8	21.5	–	7.2	21.5	31.8	66.7	58.8	33.4	7.9
25	5781-08-10-0-00	60.3	49.2	39.7	–	11.1	20.6	44.5	79.4	73	39.7	6.4
32	5781-10-13-0-00	84.2	67.5	59.5	42.1	16.7	24.6	62.7	96.8	92.8	48.4	3.8

NG	ISO-code	B1	B2	H1	H2	H3	L1	L2	D1	D2	D3	t1	D4	t2	D5	D6
10	5781-06-07-0-00	87.3	33.35	83	21	45	29	94.8	15	7	7.1	8	M10	16	10.8	17
25	5781-08-10-0-00	105	39.7	107.5	29	69.5	34.7	126.8	23.4	7.1	7.1	8	M10	18	10.8	17
32	5781-10-13-0-00	120	48.4	120	30	82	30.6	144.3	32	7.1	7.1	8	M10	20	10.8	17

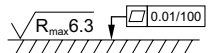
NG	Kit	 ISO 4762-12.9	 63 Nm ±15 %	Kit		Surface finish
				NBR	FPM	
10	BK505	4x M10x35	63 Nm ±15 %	S26-58507-0	S26-58507-5	
25	BK485	4x M10x45	63 Nm ±15 %	S26-58475-0	S26-58475-5	
32	BK506	6x M10x45	63 Nm ±15 %	S26-58508-0	S26-58508-5	

Dimensions D4S with VV01

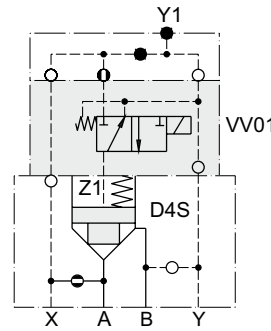
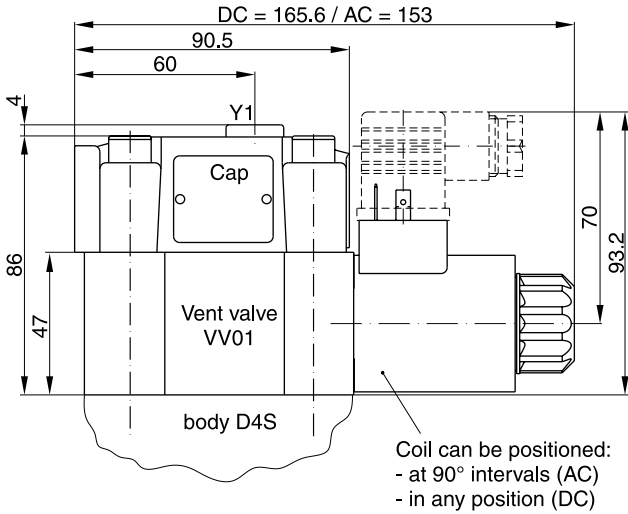

with manual override without manual override
 D4S...09/10
 Solenoid energized:
 D4S blocked
 Solenoid de-energized:
 Flow from A-B or B-A

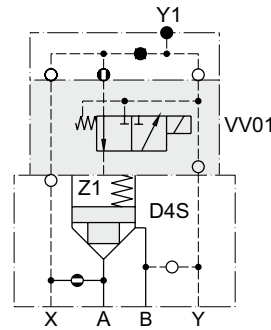

with manual override without manual override
 D4S...11/12
 Solenoid energized:
 Flow from A-B or B-A
 Solenoid de-energized:
 D4S blocked

Dimensions D4S with shuttle valve

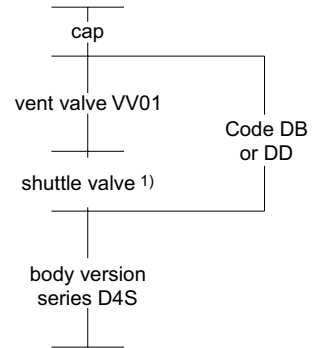
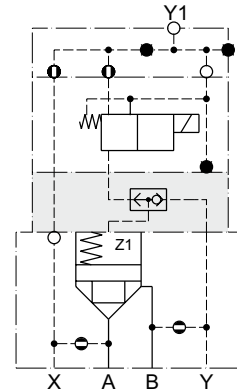
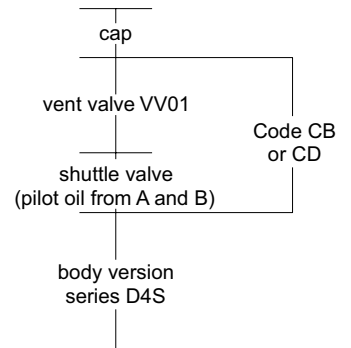
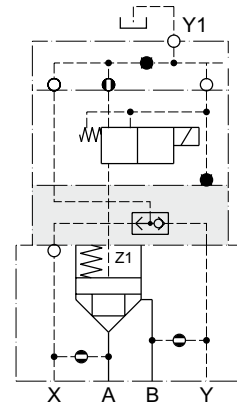
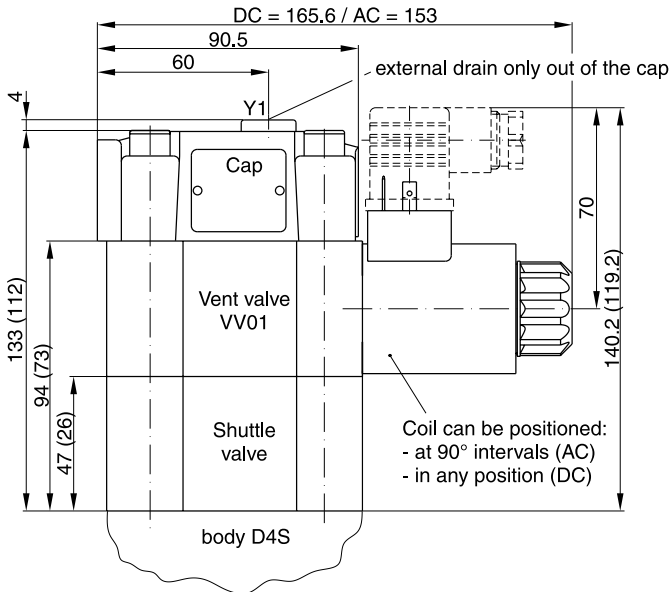

() Dimensions in brackets are for version VV01 with shuttle valve code DB or DD.

¹⁾ Pilot oil from A and B, from B to A check valve function.

Dimensions

Position control by proximity switch (incl. amplifier)

Valve open: proximity switch activated. This proximity switch is pressure proof and has no wearing parts.

Note

Position control for D4S06 and D4S10 only.

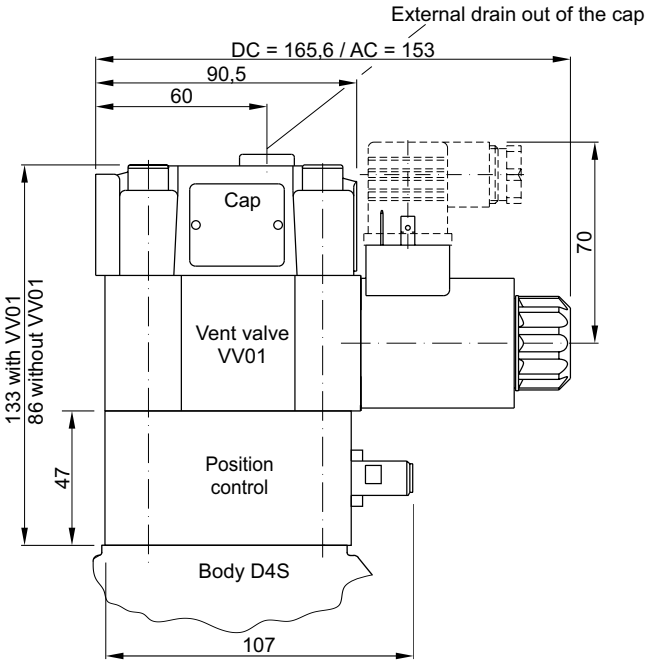

Position control as per IEC 61076-2-101 (M12x1)

Protection class	IP65 in accordance with EN 60529
Ambient temperature	[°C] -20...+60
Supply voltage U_s / ripple	[V] 10...30 / $\pm 10\%$
Current consumption without load	[mA] ≤ 10
Max. output current per channel, ohmic	[mA] 200
Min. output load per channel, ohmic	[kOhm] 100
Max. output drop at 0.2 A	[V] ≤ 2
EMC	EN61000-6-4 / EN61000-6-2
Min. distance to next AC solenoid	[m] > 0.1
Interface	M12x1 acc. to IEC 61076-2-101
Wiring min.	[mm ²] 3 x 0.14 brad shield recommended
Wiring length max.	[m] 50 recommended

6

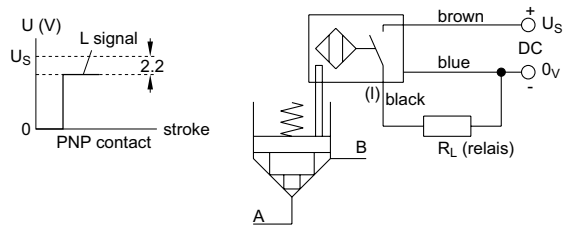

M12 pin assignment

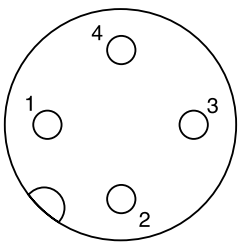

- 1 U_s 10...30 V
- 2 not connected
- 3 0 V
- 4 Out A: normally open

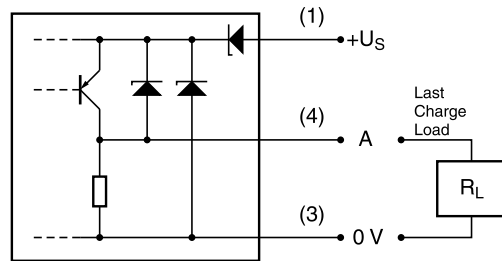

Please order plug M12 x 1 separately. Straight plug recommended – no defined position possible for angled plug.

Dimensions D4S stroke limiter

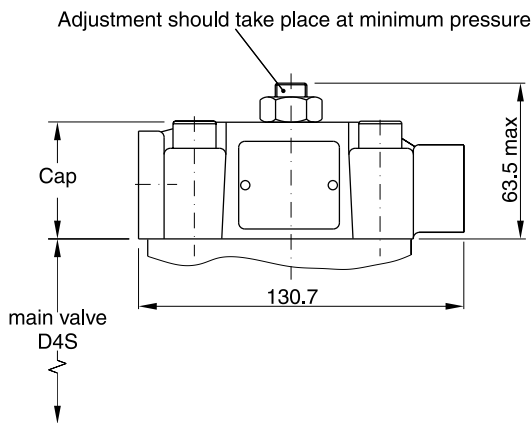

Example: D4S₁₀⁰⁶-.233B.

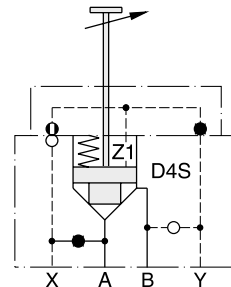

Note:

Stroke limiter not for use with D4S03, vent valve VV01, shuttle valve and position control.

D4S UK.indd 07.10.22

D4S direct operated

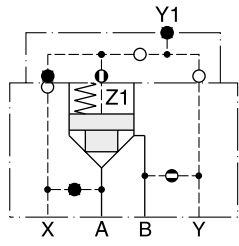

D4S...DC
 Pilot oil Y = internal from B

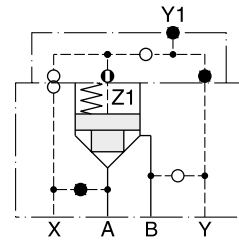

D4S...21
 Pilot oil X = external

D4S with VV01

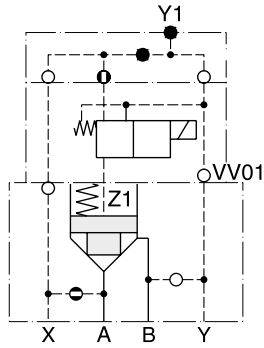

09 }
 10 } with VV01
 11 }
 12 }
 D4S...-16...
 Pilot oil X = internal from A
 Drain Y = internal to B

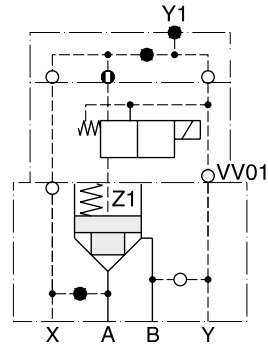

09 }
 10 } with VV01
 11 }
 12 }
 D4S...-26...
 Pilot oil X = external
 Drain Y = internal to B

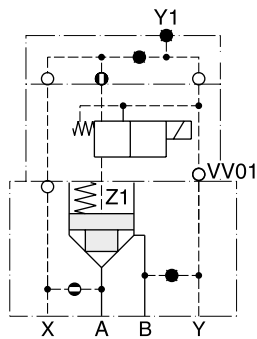

09 }
 10 } with VV01
 11 }
 12 }
 D4S...-A5...
 Pilot oil X = internal from A
 Drain Y = external to subplate

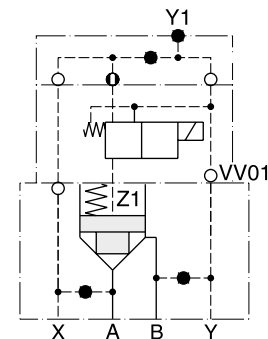

09 }
 10 } with VV01
 11 }
 12 }
 D4S...-B5...
 Pilot oil X = external
 Drain Y = external to subplate

6

D4S with VV01

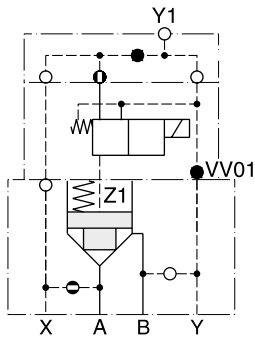

D4S...12... } with VV01
09
10
11
12

Pilot oil X = internal from A
Drain Y1 = external out of the cap

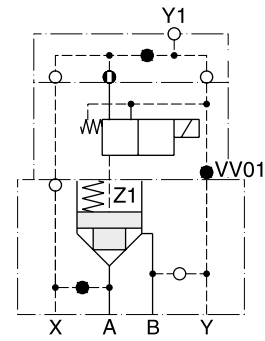

D4S...22... } with VV01
09
10
11
12

Pilot oil X = external
Drain Y1 = external out of the cap

D4S with shuttle valve

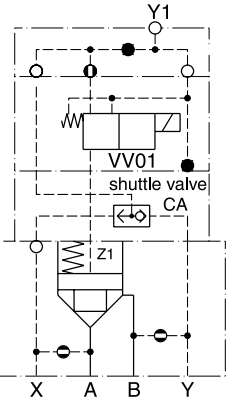

D4S...C2... } with shuttle valve CA
CB } and VV01
CD

Pilot oil = internal from A and B
Drain Y1 = external out of the cap

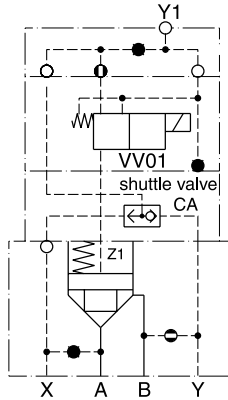

D4S...D2... } with shuttle valve CA
CB } and VV01
CD

Pilot oil = internal from B and
external from X
Drain Y1 = external out of the cap

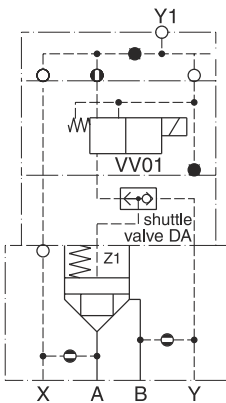

D4S...C2...- } with shuttle valve DA
DB } and VV01
DD

Pilot oil = internal from A and B
(B-A = check valve function)
Drain Y1 = external out of the cap

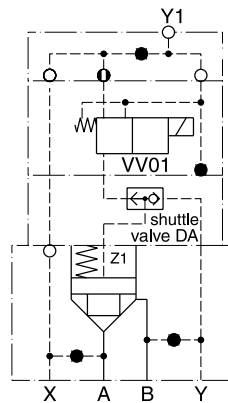

D4S...B2... } with shuttle valve DA
DB } and VV01
DD

Pilot oil = external from X and Y
Drain Y1 = external out of the cap

D4S with position control

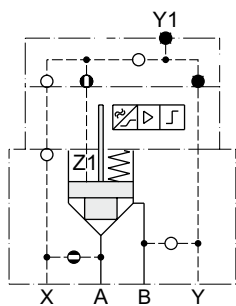

D4S...-113A.EA
 (with position control)
 Pilot oil X = internal from A

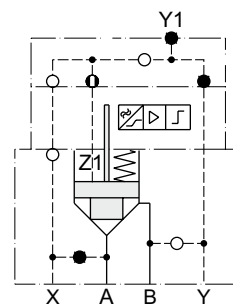

D4S...-21-3A.-EA
 (with position control)
 Pilot oil X = external

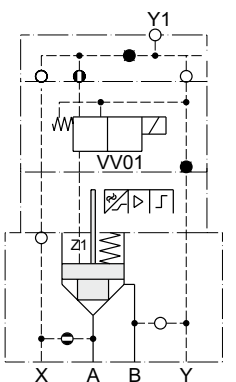

D4S...-12-3A.-
 EC } with position control
 EE } and VV01
 Pilot oil X = internal from A
 Drain Y1 = external out of the cap

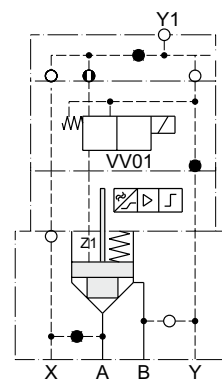

D4S...-22-3A.-
 EC } with position control
 EE } and VV01
 Pilot oil X = external
 Drain Y1 = external out of the cap

D4S with stroke limiter

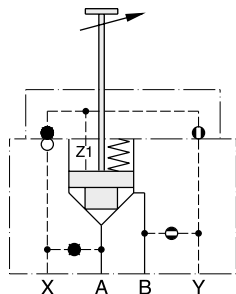

D4S...-D434. with stroke limiter
 Pilot oil Y = internal from B
 Note: for D4S06 and D4S10 only

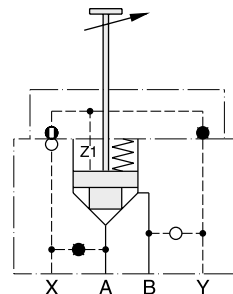

D4S...-233B. with stroke limiter
 Pilot oil X = external
 Note: for D4S06 and D4S10 only

6