

Characteristics / Ordering Code

Hydraulically pilot operated check valves C4V allow free flow from A to B. The counter-flow direction is blocked.

When pressure is applied to control port X, the ring chamber flow from B to A is released.

Up to four different pilot control ratios are available (see ordering code).

Function

When no pressure is applied to the X-port, the flow from B to A is blocked, because the pressure in B is also in effect on top of the poppet.

Pressurizing the X port relieves the area on top of the poppet to the drain port and allows flow from B to A.

The seat design of the SVL valve series provides leak-free separation of port A and B in the closed position.

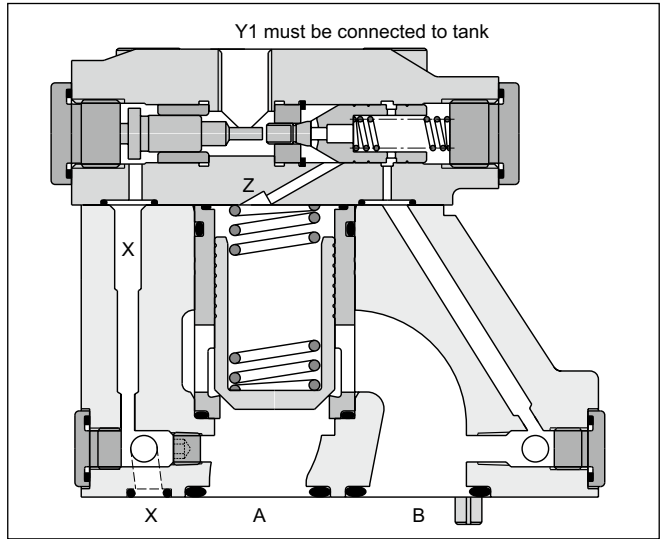
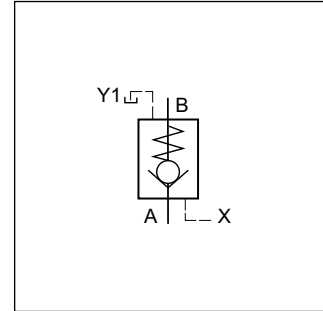

6

Ordering code

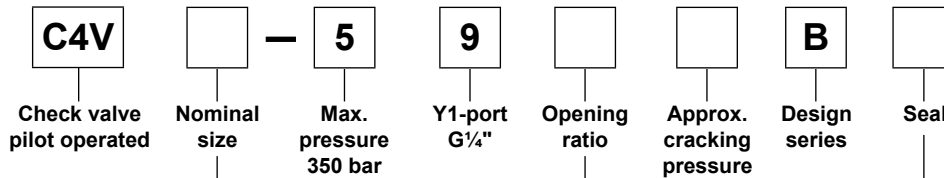

Code	Nominal size
03	NG10
06	NG25
10	NG32

Code	Opening ratio	Code	Opening ratio
1	1 : 1	K ¹⁾	1 : 1
3	3 : 1	L ¹⁾	3 : 1
8	8 : 1	M ¹⁾	8 : 1
9	10 : 1	N ¹⁾	10 : 1

Code	Seal
1	NBR
5	FPM

Code	Approx. cracking pressure [bar]			
	Flow A to B		Flow B to A	
	C4V03	C4V06/10	C4V03	C4V06/10
2	1.0	1.0	1.5	1.7
4	4.0	3.5	5.5	6.0
6	2.0	2.2	3.0	3.8

¹⁾ Position control incl. amplifier for C4V06/10 only.

Technical data

General				
Nominal size		NG10	NG25	NG32
Subplate mounting	ISO 5781			
Mounting position	Unrestricted			
Ambient temperature	[°C]	-20...+60		
MTTF _D value	[years]	150		
Weight	[kg]	2.8	4.6	6.1
Hydraulic				
Max. operating pressure	[bar]	350		
Nominal flow	[l/min]	150	270	450
Fluid	Hydraulic oil according to DIN 51524			
Fluid temperature	[°C]	-20...+70 (NBR: -25...+70)		
Viscosity,	permitted	[cSt] / [mm ² /s]	20...400	
	recommended	[cSt] / [mm ² /s]	30...80	
Filtration	ISO 4406; 18/16/13			

Δp/Q flow curve

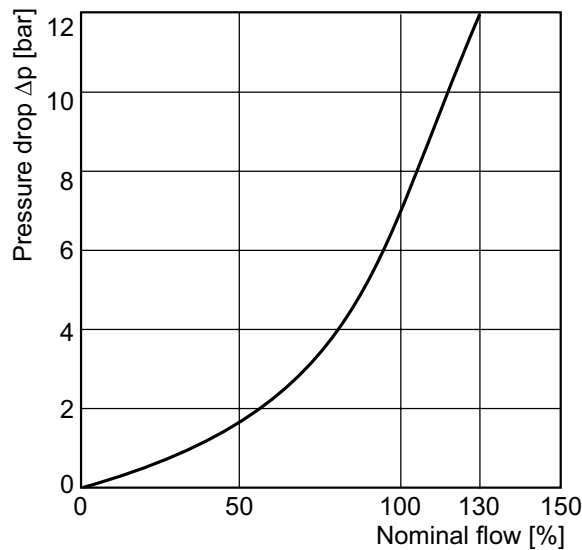

Characteristic curve measured with HLP46 at 50 °C.

Position control as per IEC 61076-2-101 (M12x1)

Protection class	IP65 in accordance with EN 60529
Ambient temperature [°C]	-20...+60
Supply voltage U_s / ripple [V]	10...30 / $\pm 10\%$
Current consumption without load [mA]	≤ 10
Max. output current per channel, ohmic [mA]	200
Min. output load per channel, ohmic [kOhm]	100
Max. output drop at 0.2 A [V]	≤ 2
EMC	EN61000-6-4 / EN61000-6-2
Min. distance to next AC solenoid [m]	> 0.1
Interface	M12x1 acc. to IEC 61076-2-101
Wiring min. [mm ²]	3 x 0.14 braid shield recommended
Wiring length max. [m]	50 recommended

Position control

Position control by proximity switch with amplifier. The closed position is monitored.

Valve open: proximity switch activated.

This proximity switch is pressure proof and has no wearing parts.

Note: Position control for C4V06 and C4V10 only.

6

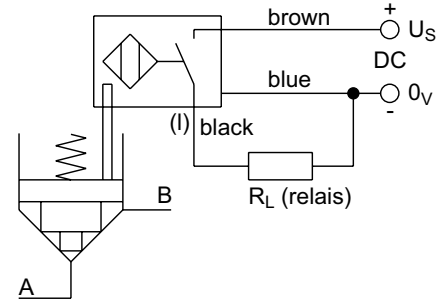
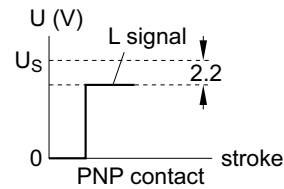
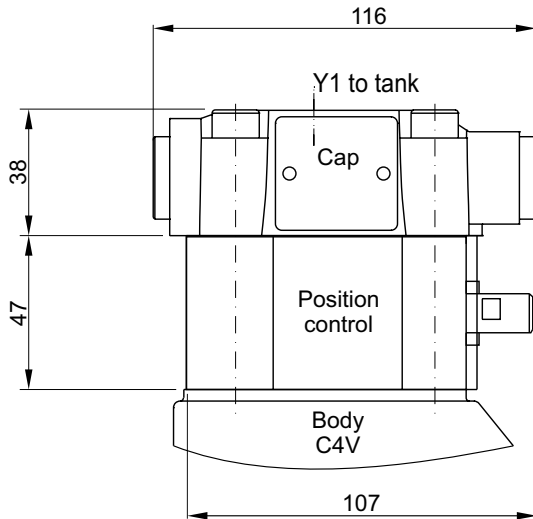

Please order plug M12 x 1 separately. Straight plug recommended – no defined position possible for angled plug.

M12 pin assignment

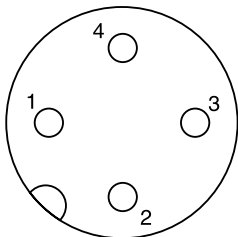

- 1 U_s 10...30 V
- 2 not connected
- 3 0 V
- 4 Out A: normally open

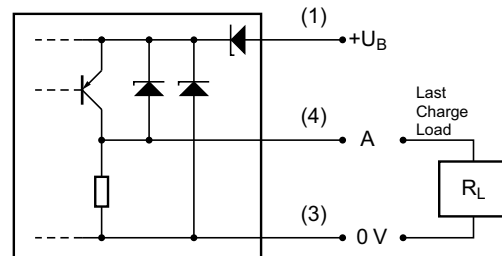

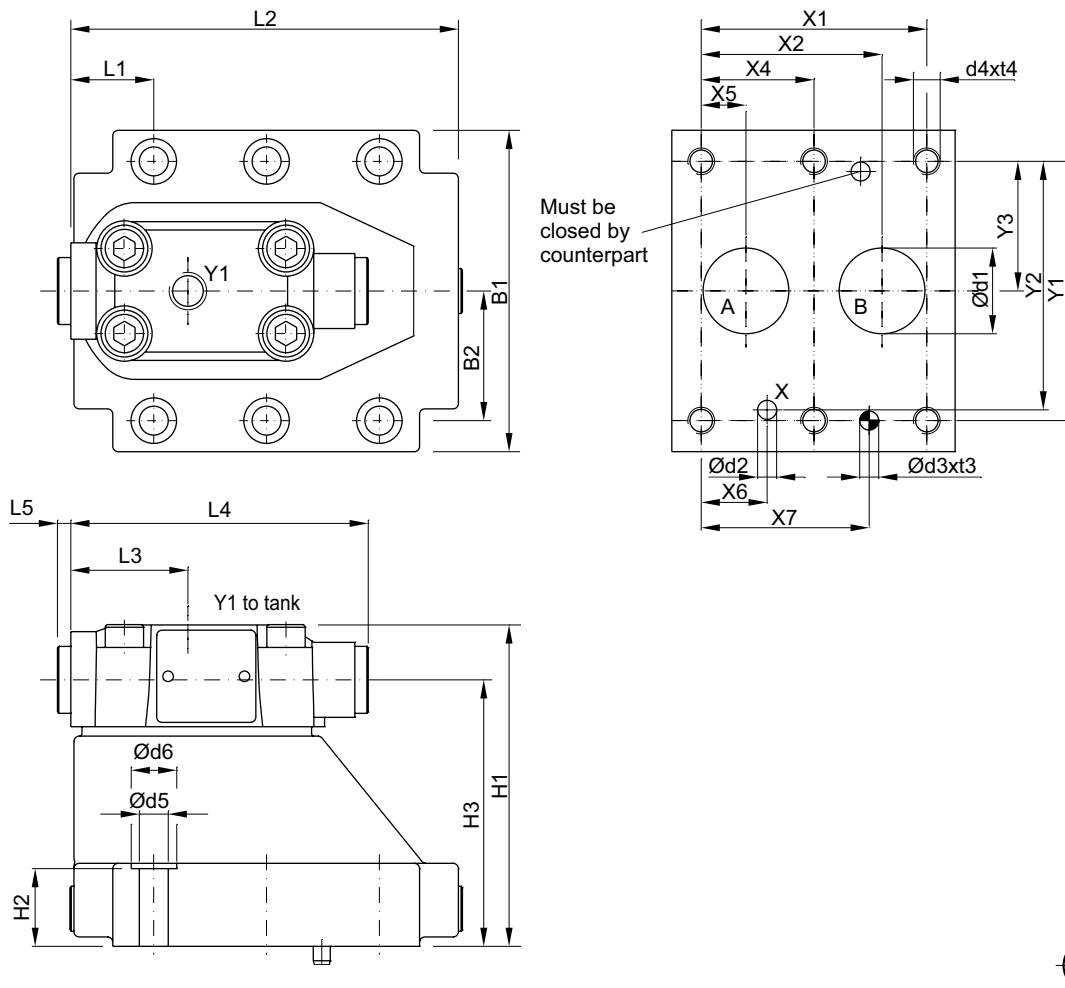

6

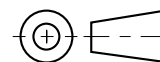

NG	ISO-code	x1	x2	x3	x4	x5	x6	x7	y1	y2	y3	y4	y5	y6
10	5781-06-07-0-00	42.9	35.8	-	-	7.2	21.5	31.8	66.7	58.8	33.4	-	-	-
25	5781-08-10-0-00	60.3	49.2	-	-	11.1	20.6	44.5	79.4	73	39.7	-	-	-
32	5781-10-13-0-00	84.2	67.5	-	42.1	16.7	24.6	62.7	96.8	92.8	48.4	-	-	-

Tolerance for all dimensions ±0.2

NG	ISO-code	B1	B2	H1	H2	H3	H4	H5	H6	L1	L2	L3	L4	L5	L6
10	5781-06-07-0-00	87.3	33.4	83	21	62.5	-	-	-	29.4	95.2	43.7	111	5	-
25	5781-08-10-0-00	105	39.7	107.5	29	87	-	-	-	35.1	127.2	43.7	111	5	-
32	5781-10-13-0-00	120	48.4	120	30	99.5	-	-	-	31	144.7	43.7	111	5	-

NG	ISO-code	d1max	d2max	d3	t3	d4	t4	d5	d6
10	5781-06-07-0-00	15	7	7.1	8	M10	16	10.8	17
25	5781-08-10-0-00	23.4	7.1	7.1	8	M10	18	10.8	17
32	5781-10-13-0-00	32	7.1	7.1	8	M10	20	10.8	17

NG	ISO-code	Bolt kit			Kit		Surface finish
					NBR	FPM	
10	5781-06-07-0-00	BK505	4x M10x35 ISO 4762-12.9	63 Nm ±15 %	S26-58507-0	S26-58507-5	
25	5781-08-10-0-00	BK485	4x M10x45 ISO 4762-12.9	63 Nm ±15 %	S26-58475-0	S26-58475-5	
32	5781-10-13-0-00	BK506	6x M10x45 ISO 4762-12.9	63 Nm ±15 %	S26-58508-0	S26-58508-5	