

Characteristics

The proportional solenoid operated pilot stage with integrated electronics controls a seated type main stage. The valves are optionally available with a mechanical maximum pressure adjustment.

The onboard electronics of the proportional pressure relief valves is based on the functionality of the digital amplifier PCD00.

The digital onboard electronics is situated in a robust metal housing and can be used in rough environments.

The nominal values of the valves are factory set. Additionally the ProPxD software permits the editing of all parameters. The software is also used for the digital electronic modules. The cable for connection to a serial RS232C interface is available as accessory.

The electrical connection is available in 2 options:

- Code 10V: 6 + PE central connection
0...+10 V command signal
+10 V reference voltage output
- Code 4MA: 6 + PE central connection
4...20 mA command signal

Features

- Pilot operated with proportional solenoid
- Onboard electronics factory set
- Ramp time adjustment
- Linearized characteristics
- 3 pressure stages
- 2 interfaces:
 - R4V subplate ISO 6264 (DIN 24340 Form D)
 - R6V subplate ISO 6264 (DIN 24340 Form E)
- Optional mechanical maximum pressure adjustment

4



R6V06

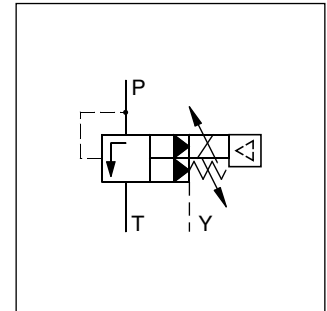

R6V

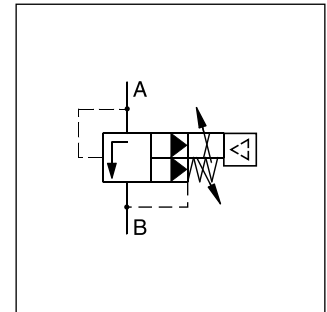

R4V

R4V06

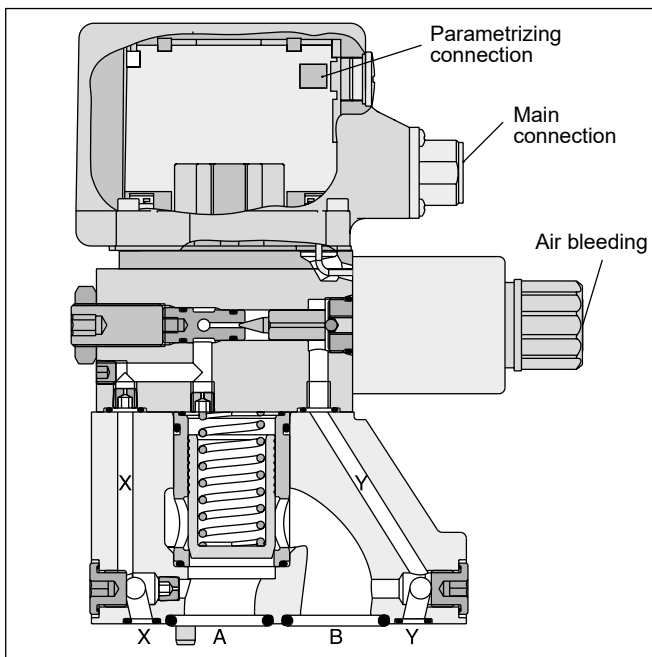

R6V06

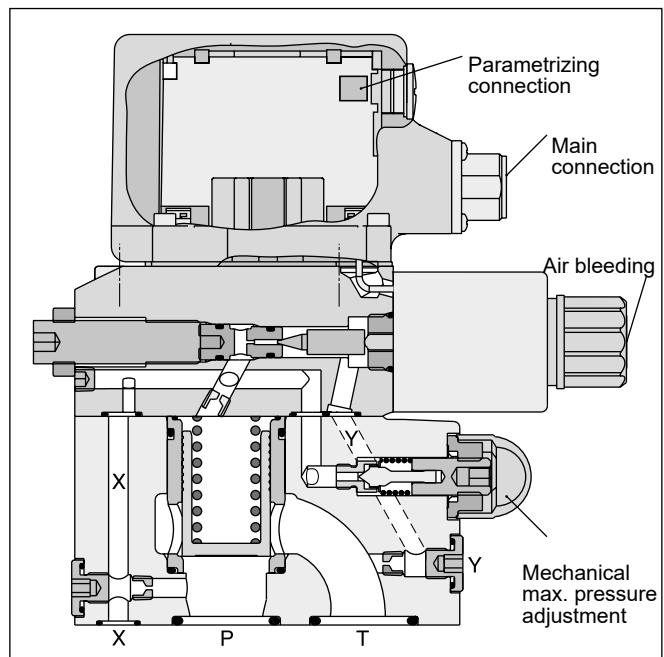

Ordering Code

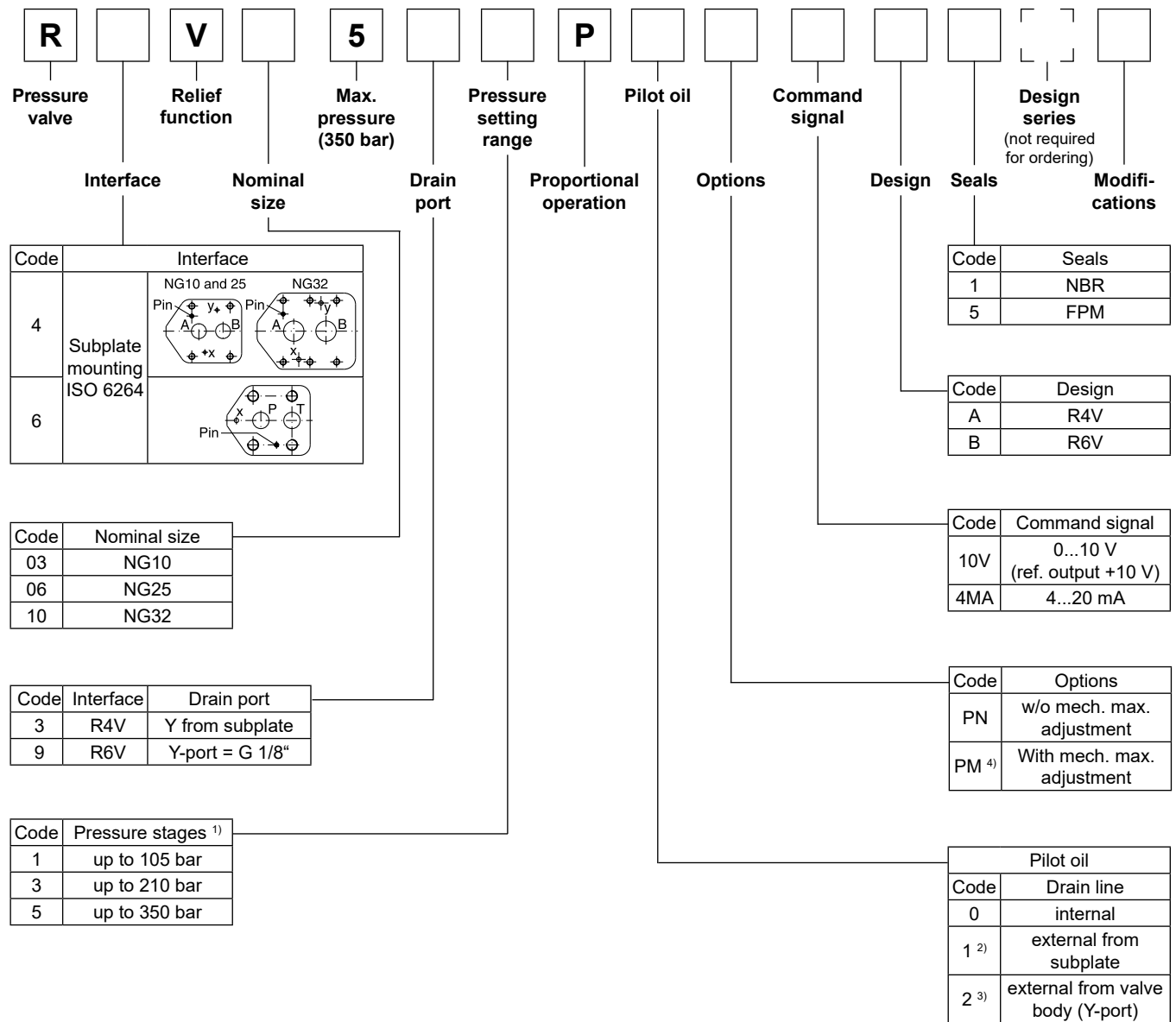

4

Please order plugs separately, see chapter 4, accessories.
Parametrizing cable OBE® RS232, item no. 40982923.

¹⁾ Other pressure stages on request.
²⁾ R4V only.
³⁾ R6V only.
⁴⁾ R4V: adjustment with acorn nut.

General			
Nominal size			NG10 NG25 NG32
Interface	Subplate mounting acc. ISO 6264		
Mounting position	Unrestricted, horizontal mounting preferred		
Ambient temperature	[°C]	-20...+60	
MTTF _D value ¹⁾	[years]	75	
Weight	Series R4V	[kg]	4.5 6.3 7.8
	Series R6V	[kg]	5.4 6.6 8.6
Vibration strength	[g]	10 sinus 5...2000 Hz acc. to IEC 68-2-6	
		10 (RMS) noise 20...2000 Hz acc. to IEC 68-2-36	
		15 shock acc. to IEC 68-2-27	
Hydraulic			
Max. operating pressure	[bar]	Ports P (or A) and X up to 350, port T (or B) and Y 30	
Pressure stages	[bar]	105, 210, 350	
Nominal flow	Series R4V	[l/min]	90 300 600
	Series R6V	[l/min]	250 500 650
Fluid	Hydraulic oil according to DIN 51524		
Viscosity, permitted recommended	[cSt] / [mm ² /s]	20 ... 400	
	[cSt] / [mm ² /s]	30 ... 80	
Fluid temperature	[°C]	-20...+70 (NBR: -25...+70)	
Filtration		ISO 4406; 18/16/13	
Hysteresis	[%]	< 1.5	
Electrical			
Duty ratio ED	[%]	100	
Protection class		IP65 in accordance with EN 60529 (with correctly mounted plug-in connector)	
Supply voltage	VDC	18...30, ripple < 5 % eff., surge free	
Current consumption max.	[A]	2.0	
Pre-fusing	[A]	2.5 medium lag	
Potentiometer supply	[V]	+10 / ±5 % max. 10 mA	
Command signal	[V]	0...+10, ripple < 0.01 % eff., surge free, Ri = 100 kOhm	
	[mA]	4...20, ripple < 0.01 % eff., surge free, Ri = <250 Ohm < 3.6 mA = enable off, > 3.8 mA = enable on (acc. NAMUR NE43)	
Differential input voltage max.	[V]	30 for terminal D and E against PE (terminal G)	
	[V]	11 for terminal D and E against 0V (terminal B)	
Adjustment ranges	Min current	[%]	0...50
	Max current	[%]	50...100
	Ramp	[s]	0...32.5
Interface		RS232C, parametrizing connection 5pole	
EMC		EN 61000-6-2, EN 61000-6-4	
Central connection		6 + PE acc. EN 175201-804	
Cable specification	[mm ²]	7 x 1.0 overall braid shield	
Cable length max.	[m]	50	

¹⁾ If valves with onboard electronics are used in safety-related parts of control systems, in case the safety function is requested, the valve electronics voltage supply is to be switched off by a suitable switching element with sufficient reliability.

R4V/R6V

Command/pressure curve

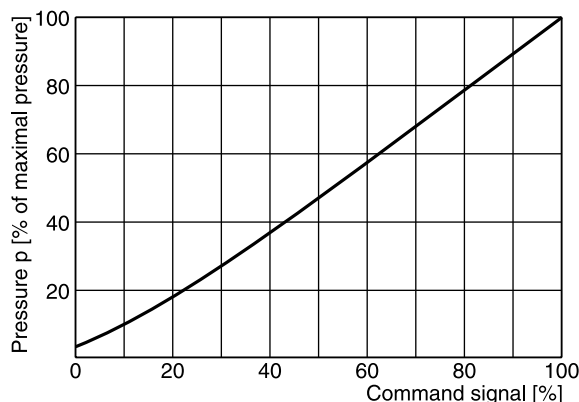

4

p/Q performance curves ¹⁾

R4V / R6V03

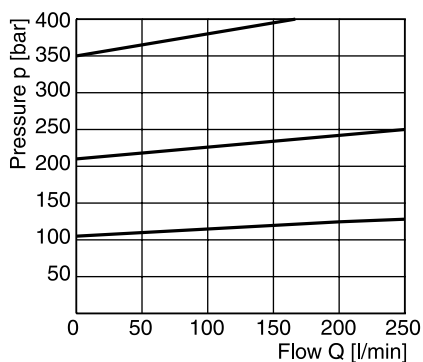

R4V / R6V06

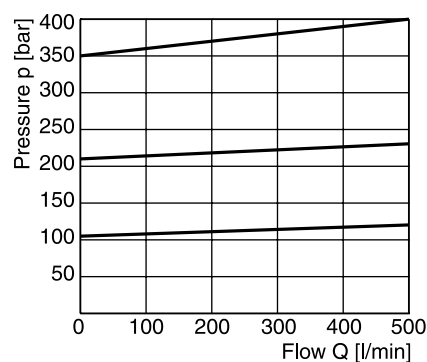

R4V / R6V10

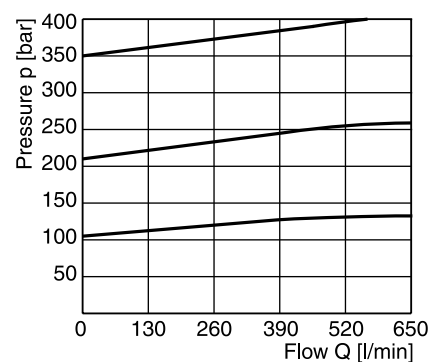

Minimum pressure curves ¹⁾

R4V / R6V03

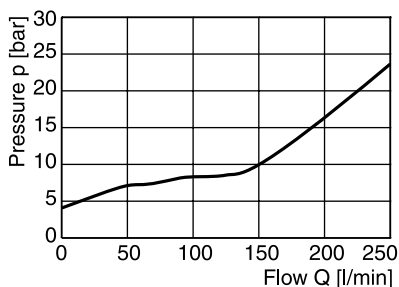

R4V / R6V06

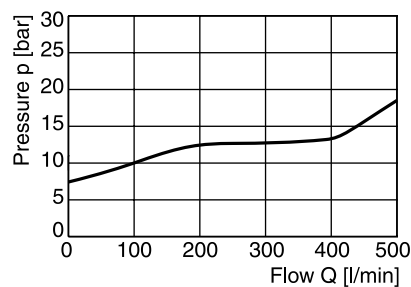

R4V / R6V10

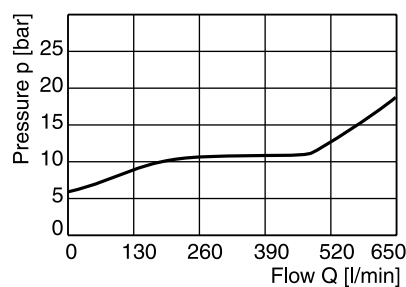

All characteristic curves measured with HLP46 at 50 °C.

¹⁾ The performance curves are measured with external drain.
 For internal drain the tank pressure has to be added to curve.

Block diagram

Code 10V

6 + PE acc. EN 175201-804

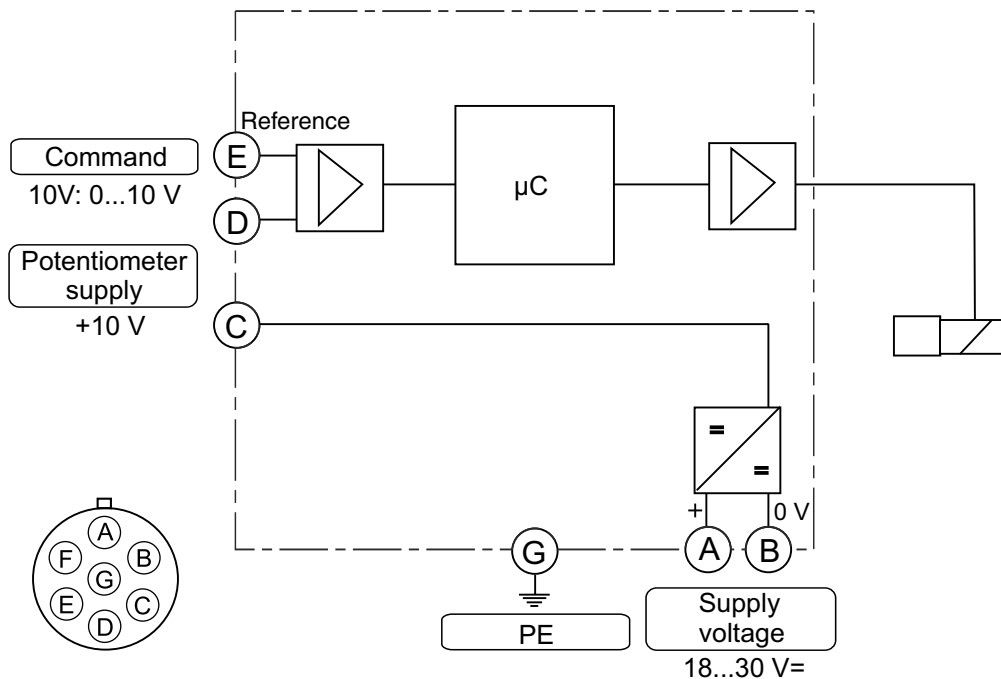

Code 4MA

6 + PE acc. EN 175201-804

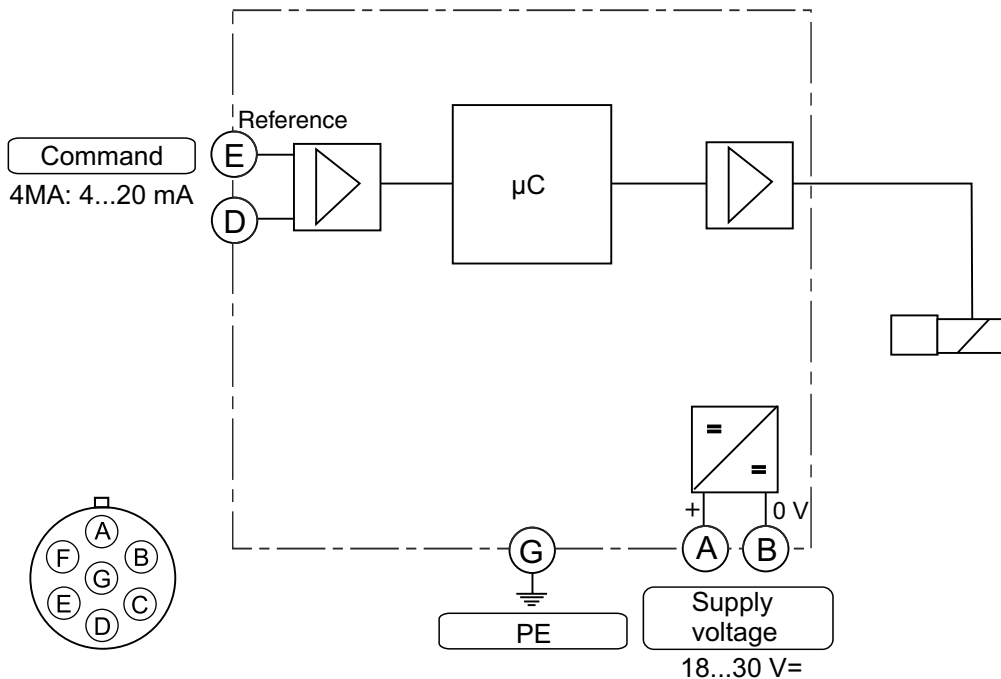

ProPxD interface program

The ProPxD software permits comfortable parameter setting for the module electronics. Via the clearly arranged entry mask the parameters can be noticed and modified. Storage of complete parameter sets is possible as well as printout or record as a text file for further documentation. Stored parameter sets may be loaded anytime and transmitted to other valves. Inside the electronics a non-volatile memory stores the data with the option for recal-ling or modification.

The PC software can be downloaded free of charge at www.parker.com/isde – see page “Support“ or directly at www.parker.com/propxd.

Features

- Comfortable editing of all parameters
- Depiction and documentation of parameter sets
- Storage and loading of optimized parameter adjust-ments
- Executable with all actual Windows® operating systems from Windows® XP upwards
- Plain communication between PC and electronics via serial interface RS232C

The parametrizing cable may be ordered under item no. 40982923.

4

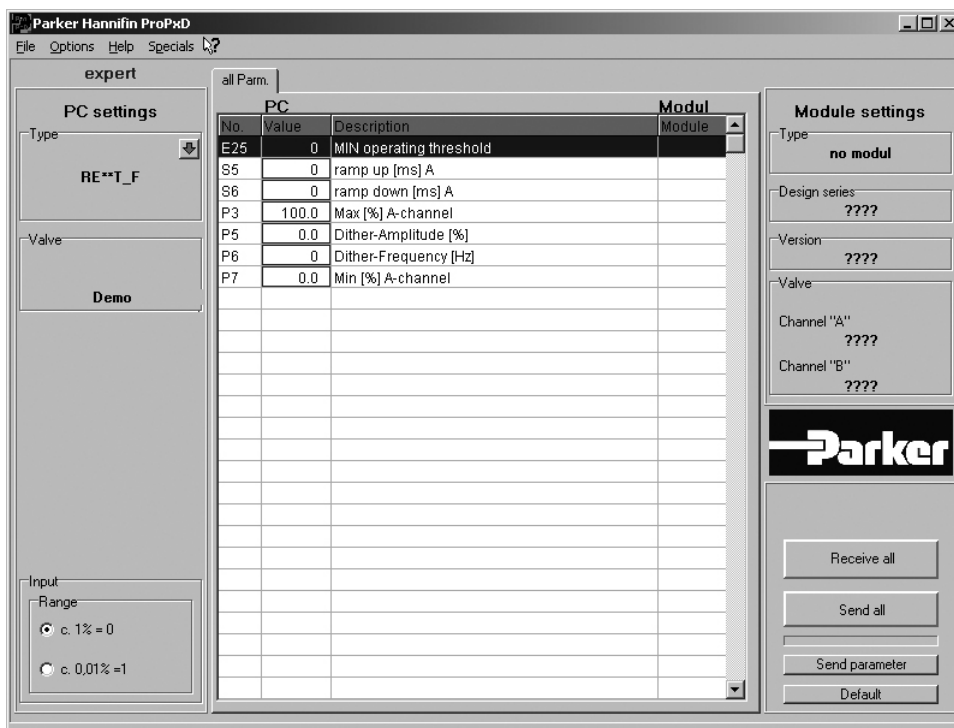

R4V

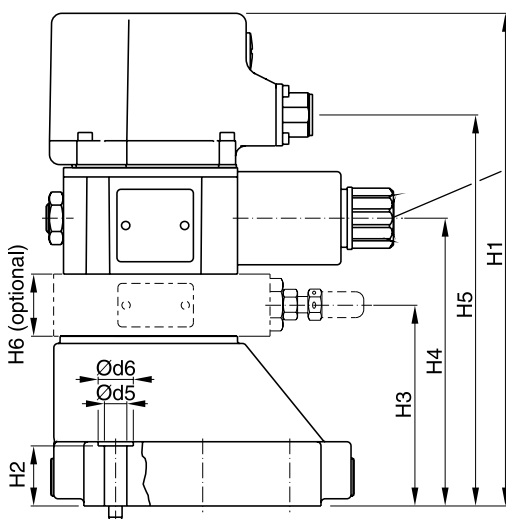
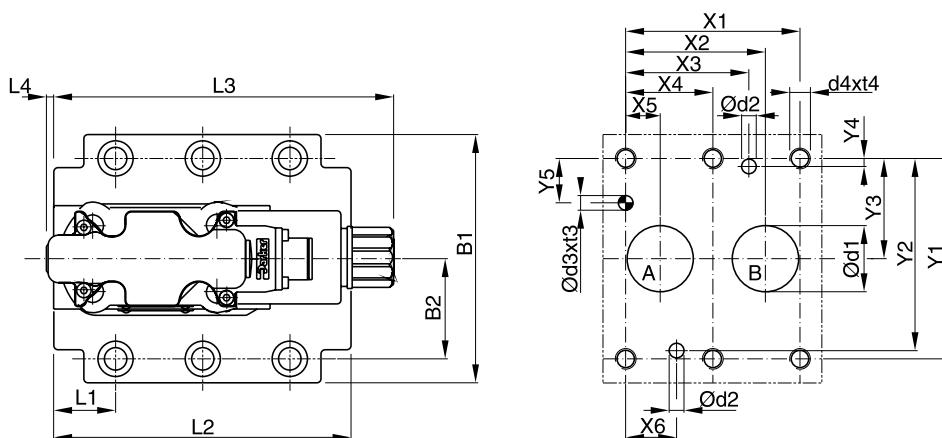

Important:
 On initial start up and
 after long shut down periods
 bleed air from this plug.

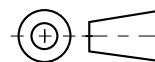

NG	ISO-code	x1	x2	x3	x4	x5	x6	x7	y1	y2	y3	y4	y5	y6
10	6264-06-07-*-97	42.9	35.8	21.5	–	7.2	21.5	0	66.7	58.8	33.4	7.9	14.3	–
25	6264-08-11-*-97	60.3	49.2	39.7	–	11.1	20.6	0	79.4	73	39.7	6.4	15.9	–
32	6264-10-15-*-97	84.2	67.5	59.5	42.1	16.7	24.6	0	96.8	92.8	48.4	3.8	21.4	–

Tolerance at X and Y pin holes and screw holes ± 0.1 , at port holes ± 0.2 .

NG	ISO-code	B1	B2	H1	H2	H3	H4	H5	H6	L1	L2	L3	L4	L5	L6
10	6264-06-07-*-97	87.3	33.35	204.7	21	62	103	148.2	32	25	90.8	164.2	4.5	–	–
25	6264-08-11-*-97	105	39.7	229.2	29	86.5	127.5	172.7	32	30.9	123	164.2	4.5	–	–
32	6264-10-15-*-97	120	48.4	241.7	30	99	140	185.2	32	29.8	143.5	164.2	4.5	–	–

NG	ISO-code	d1max	d2max	d3	t3	d4	t4	d5	d6	Subplate ¹⁾
10	6264-06-07-*-97	15	7	7.1	8	M10	16	10.8	17	SPP 3M6B 910
25	6264-08-11-*-97	23.4	7.1	7.1	8	M10	18	10.8	17	SPP 6M8B 910
32	6264-10-15-*-97	32	7.1	7.1	8	M10	20	10.8	17	SPP 10M12B 910

NG	Bolt kit			Kit		Surface finish
				NBR	FPM	
10	BK505	4x M10x35 ISO 4762-12.9	63 Nm ± 15 %	S26-58507-0 ²⁾	S26-58507-5 ²⁾	
25	BK485	4x M10x45 ISO 4762-12.9	63 Nm ± 15 %	S26-58475-0 ²⁾	S26-58475-5 ²⁾	
32	BK506	6x M10x45 ISO 4762-12.9	63 Nm ± 15 %	S26-58508-0 ²⁾	S26-58508-5 ²⁾	
Prop. section P2				S26-58473-0	S26-58473-5	

¹⁾ Details see chapter 12, series SPP.

²⁾ Please combine seal kit of one size with seal kit of Prop. section P2 for complete seal kit.

R6V

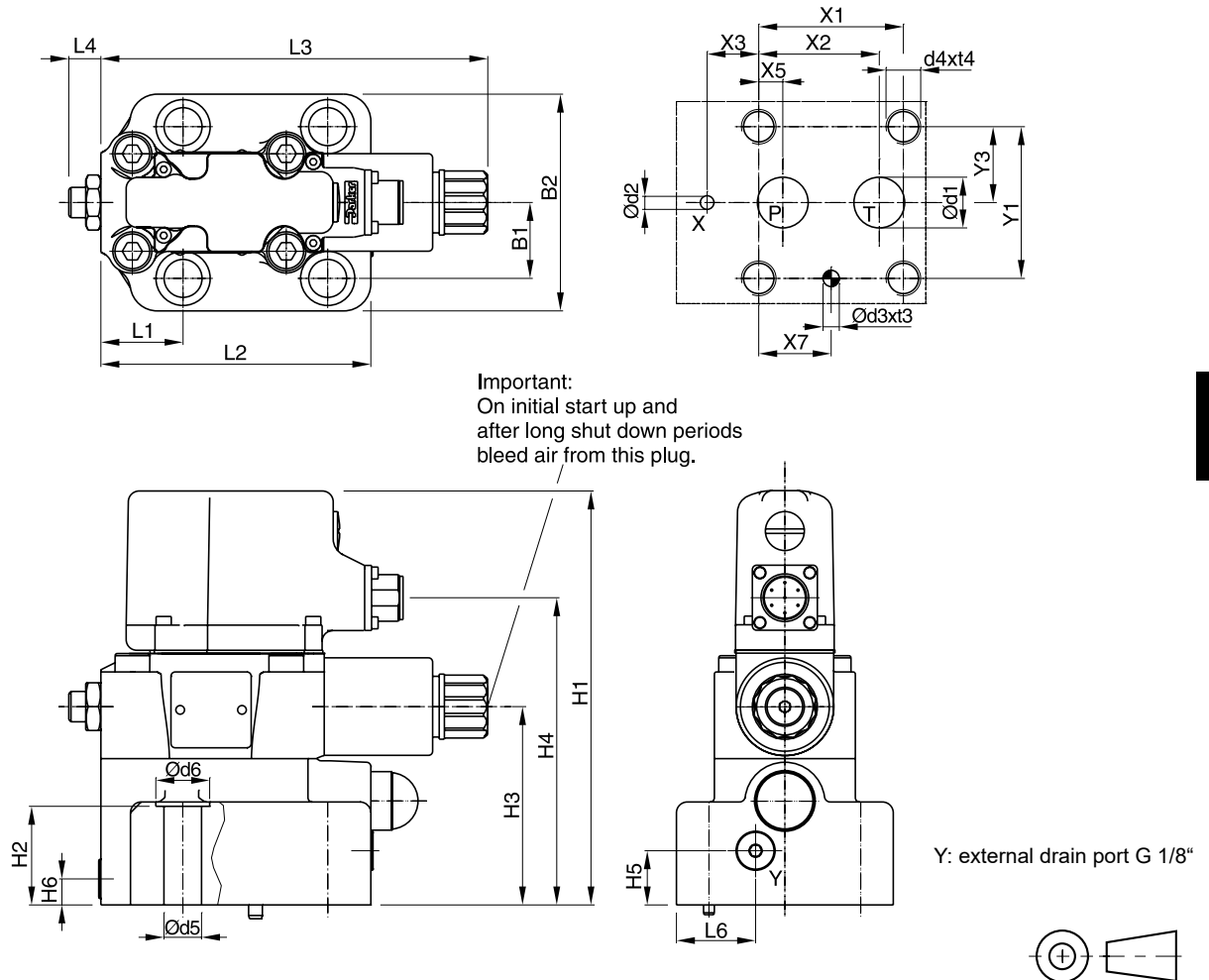

4

NG	ISO-code	x1	x2	x3	x4	x5	x6	x7	y1	y2	y3	y4	y5	y6
10	6264-06-09-*-97	53.8	47.5	0	-	22.1	-	22.1	53.8	-	26.9	-	-	-
25	6264-08-13-*-97	66.7	55.6	23.8	-	11.1	-	33.4	70	-	35	-	-	-
32	6264-10-17-*-97	88.9	76.2	31.8	-	12.7	-	44.5	82.6	-	41.3	-	-	-

Tolerance at X and Y pin holes and screw holes ±0.1, at port holes ±0.2.

NG	ISO-code	B1	B2	H1	H2	H3	H4	H5	H6	L1	L2	L3	L4	L5	L6
10	6264-06-09-*-97	80	26.9	187.2	27	88	138.2	20.5	25	52	117	182.3	14.4	-	29.5
25	6264-08-13-*-97	100	35	190.7	46.5	91.5	141.7	25	12	37.9	124.5	182.3	14.4	-	36.5
32	6264-10-17-*-97	120	41.3	197.7	51.3	98.5	148.7	26.5	13.5	44.3	153	182.3	14.4	-	46.5

NG	ISO-code	d1max	d2max	d3	t3	d4	t4	d5	d6	Subplate ¹⁾
10	6264-06-09-*-97	14.7	4.8	7.5	10	M12	20	13.5	20	SPP 3R6B 910
25	6264-08-13-*-97	23.4	6.3	7.5	10	M16	27	17.5	25	SPP 6R10B 910
32	6264-10-17-*-97	32	6.3	7.5	10	M18	28	20	30	SPP 10R12B 910

NG	Bolt kit			Kit		Surface finish
				NBR	FPM	
10	BK494	4x M12x45 ISO 4762-12.9	108 Nm ±15 %	S26-98589-0	S26-98589-5	
25	BK366	4x M16x70 ISO 4762-12.9	264 Nm ±15 %	S26-96396-0	S26-96396-5	
32	BK507	4x M18x75 ISO 4762-12.9	398 Nm ±15 %	S26-96392-0	S26-96392-5	

¹⁾ Details see chapter 12, series SPP.