

Subplate mounted proportional pressure reducing valves series R4R have a proportional solenoid operated pilot stage and a cartridge main stage.

The optimum performance can be achieved in combination with the digital amplifier module PCD00A-400.

Features

- Pilot operated with proportional solenoid
- Continuous adjustment by proportional solenoid
- Subplate mounting according to ISO 5781
- 3 pressure stages
- With mechanical maximum pressure adjustment

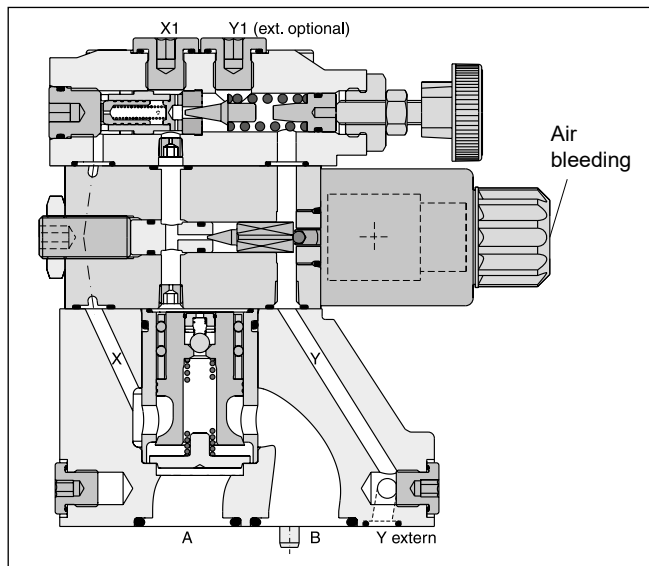
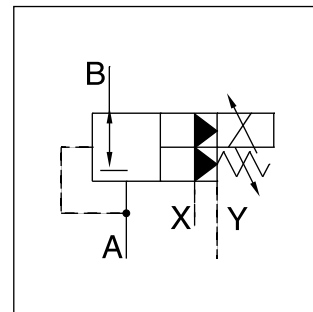

4

Ordering code

R	4	R		- 5	9				P2	G0R	B		
Pressure valve	Interface	Reducing function	Nominal size	Max. pressure 350 bar	Pilot ports G1/4"	Pressure stages	Adjustment	Pilot oil	Prop. operation	Solenoid voltage 12 V, 2.3 A	Design series	Seal	Modifications

Interface	
Code	Interface
4	Subplate mounting ISO 5781

Nominal size	
Code	Nominal size
03	NG10
06	NG25
10	NG32

Pressure stages	
Code	Pressure stages
1	up to 105 bar
3	up to 210 bar
5	up to 350 bar

Seals	
Code	Seals
1	NBR
5	FPM

Pilot oil		
Code	Pilot	Drain
1	Internal	External from Y
2	Internal	External from Y1

Adjustment	
Code	Adjustment
1	Hand knob 32 mm diameter (standard)
3	Acorn nut with lead seal

Reduced pressure pA versus flow Q

R4R03 ¹⁾

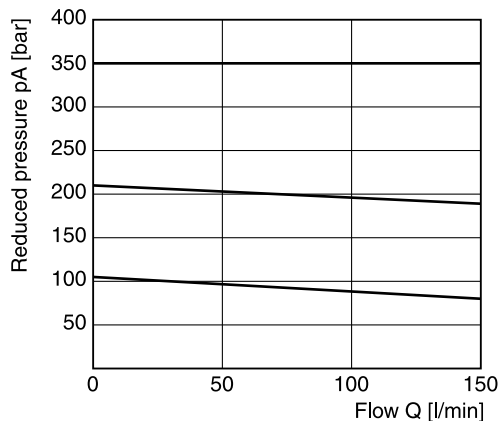

Minimum pressure curve

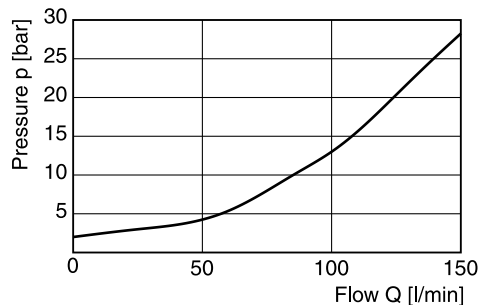

Reduced pressure pA versus flow Q

R4R06 ¹⁾

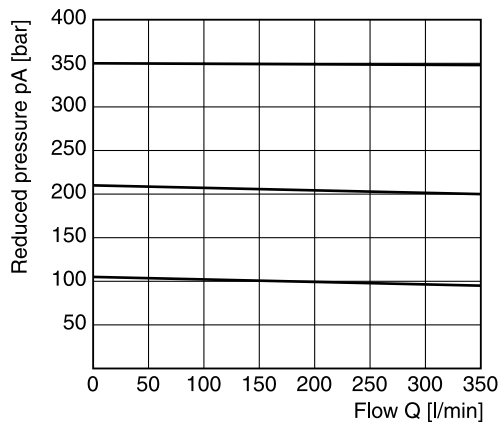

Minimum pressure curve

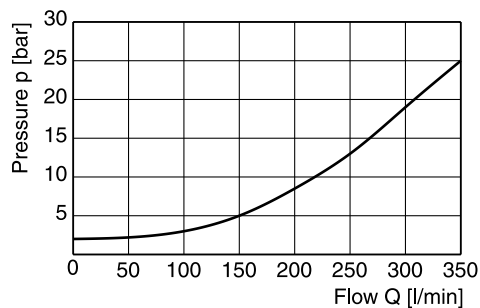

Reduced pressure pA versus flow Q

R4R10 ¹⁾

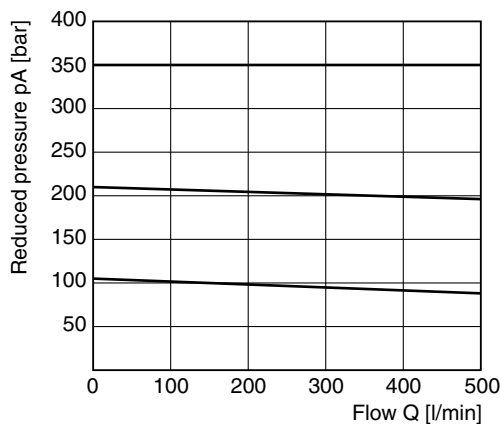

Minimum pressure curve

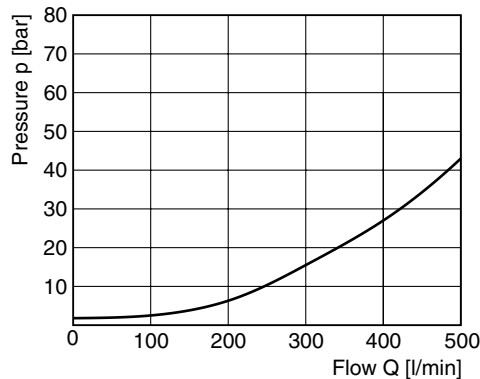

All characteristic curves measured with HLP46 at 50 °C.

¹⁾ Measured at 350 bar primary pressure pB.

4

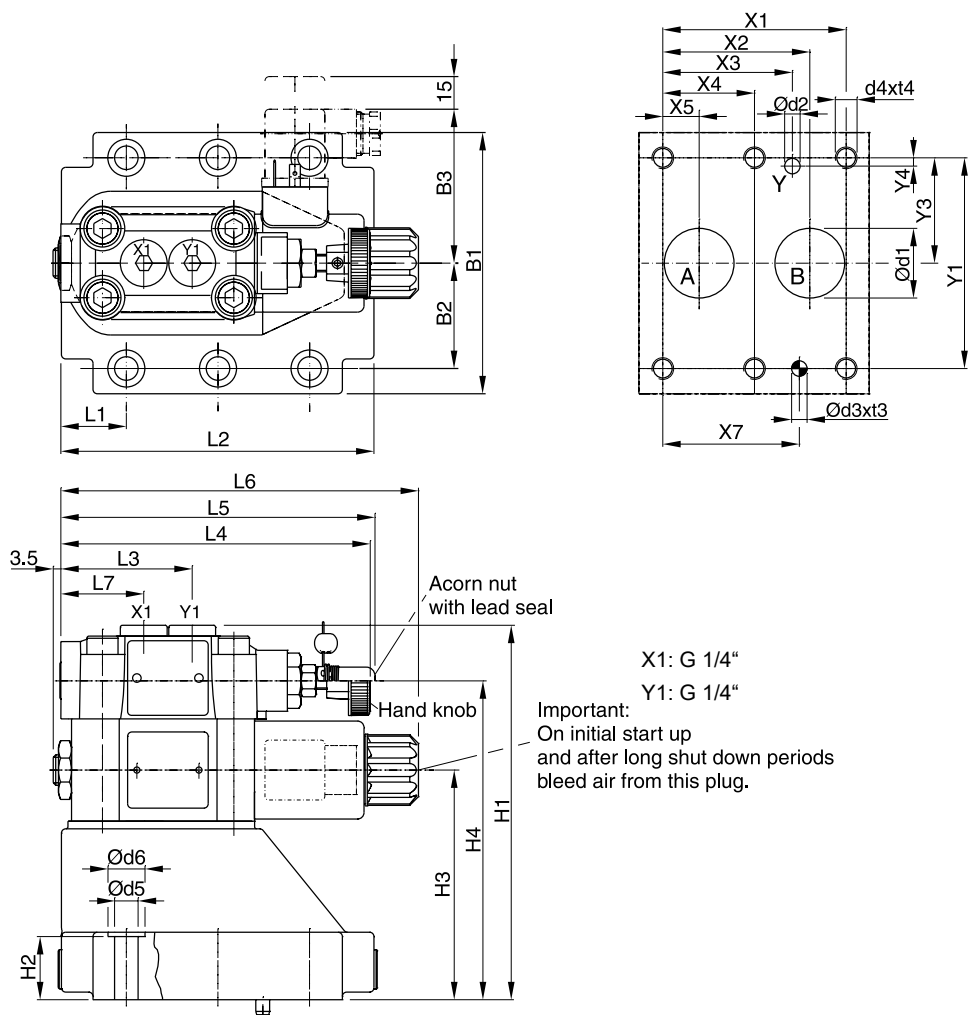

NG	ISO-code	x1	x2	x3	x4	x5	x6	x7	y1	y2	y3	y4	y5	y6
10	5781-06-07-0-00	42.9	35.8	21.5	-	7.2	-	31.8	66.7	-	33.4	7.9	-	-
25	5781-08-10-0-00	60.3	49.2	39.7	-	11.1	-	44.5	79.4	-	39.7	6.4	-	-
32	5781-10-13-0-00	84.2	67.5	59.5	42.1	16.7	-	62.7	96.8	-	48.4	3.8	-	-

Tolerance for all dimensions ± 0.2

NG	ISO-code	B1	B2	B3	H1	H2	H3	H4	L1	L2	L3	L4	L5	L6	L7
10	5781-06-07-0-00	87.3	33.35	71	134	21	68.5	109.5	25	90.8	60.8	143	144.8	164.8	38.6
25	5781-08-10-0-00	105	39.7	71	158.5	29	93	134	30.9	123	60.8	143	144.8	164.8	38.6
32	5781-10-13-0-00	120	48.4	71	171	30	105.5	146.5	29.8	143.5	60.8	143	144.8	164.8	38.6

NG	ISO-code	d1max	d2max	d3	t3	d4	t4	d5	d6	Subplate ¹⁾
10	5781-06-07-0-00	15	7	7.1	8	M10	16	10.8	17	SPP 3M6B 910
25	5781-08-10-0-00	23.4	7.1	7.1	8	M10	18	10.8	17	SPP 6M8B 910
32	5781-10-13-0-00	32	7.1	7.1	8	M10	20	10.8	17	SPP 10M12B 910

NG	Bolt kit			Kit		Surface finish
				NBR	FPM	
10	BK505	4x M10x35 ISO 4762-12.9	63 Nm ± 15 %	S26-58507-0 ²⁾	S26-58507-5 ²⁾	
25	BK485	4x M10x45 ISO 4762-12.9	63 Nm ± 15 %	S26-58475-0 ²⁾	S26-58475-5 ²⁾	
32	BK506	6x M10x45 ISO 4762-12.9	63 Nm ± 15 %	S26-58508-0 ²⁾	S26-58508-5 ²⁾	
Prop. section P2				S26-58473-0	S26-58473-5	

¹⁾ Details see chapter 12, series SPP.

²⁾ Please combine seal kit of one size with seal kit of Prop. section P2 for complete seal kit.