



100P Series

High Pressure Filters



ENGINEERING YOUR SUCCESS.

100P Series

Features

- Pressures to 6,000 PSI
- Flows to 265 GPM
- Multiple Micron Microglass Elements
- 1½" and 2" Ports - SAE O-Ring or Code 62 Flange
- Reverse Flow Option

Specifications:

Flow Rating: 265 GPM
Operating Pressure: 6000 PSI
Proof Pressure: 9000 PSI
Burst Pressure: 12,000 PSI
Fatigue Pressure: 0-4000 PSI@3,000,000 cycles
Bypass Setting: 100 PSID
Fluid Temperature: -40°F to +212°F

Construction:

Head and Cap: Nodular Iron
 Bowl: Seamless Steel Tube

Indicators: Brass

Elements: Consult Factory

Weight: Length 2 - 104 Lbs.

Electrical Ratings:

Hirschman Connector without Lamps:
 E2 110 VAC, .5 Amp Ind., 2 Amp Res.
 250 VAC, .5 Amp Ind., 2 Amp Res.
 28 VDC, 1 Amp Ind., 2 Amp Res.

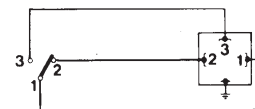

Plug connections	PIN code
Common live in	1
Normally closed live out	2
Normally open live out	3

Dimensions Inches (mm)

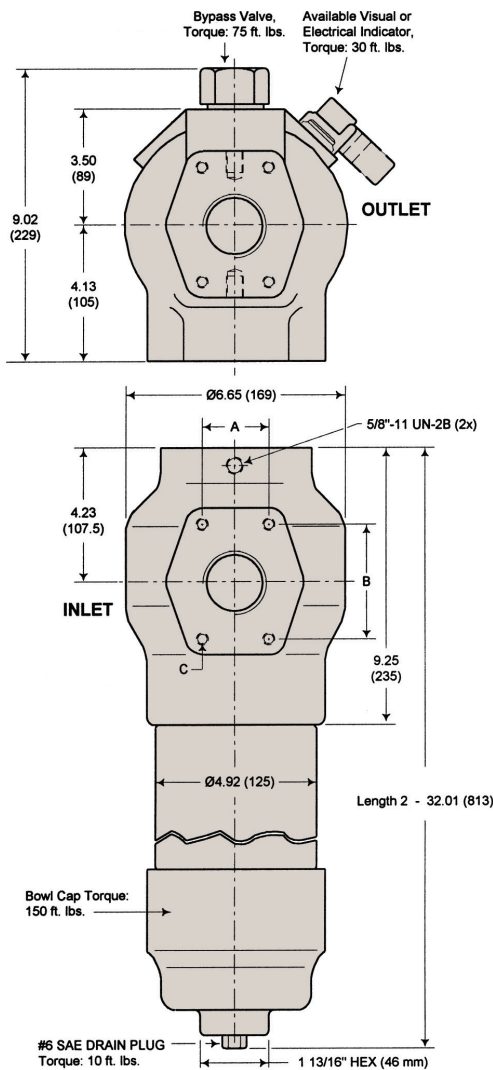

Optional Mounting Bracket

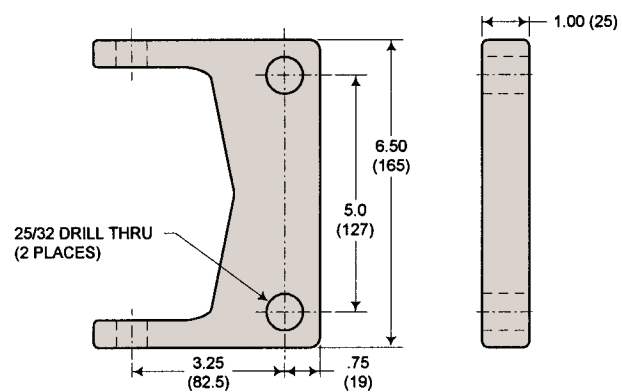

Port	Dimensions in (mm)		
	A	B	C
F	1.437 (36.5)	3.125 (79.4)	5/8" - 11 x 1.4"
T	1.750 (44.5)	3.812 (96.8)	3/4" - 10 x 1.4"

100P Series

Element Performance

Flow/Pressure Drop Data

Fluid Conditions: Viscosity 140 SSU and Sp. Gr. 0.88

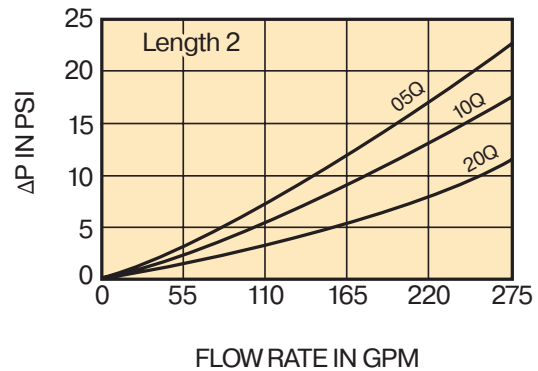
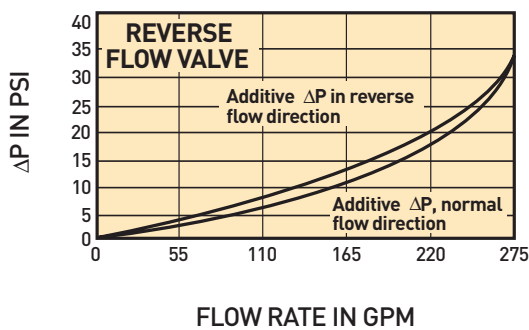
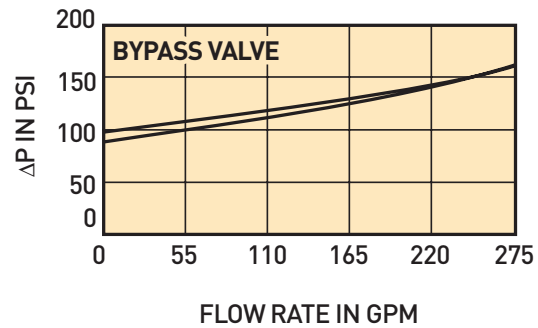
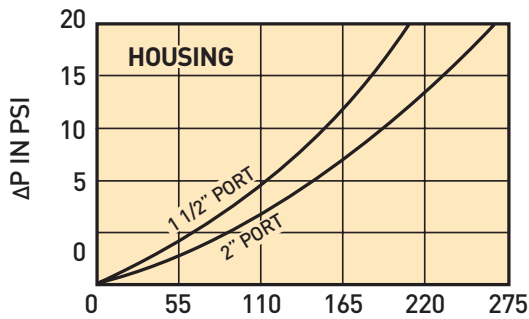

Multipass Test Results to ISO 4572 (Time Weighted Average)

Media Code	Filtration Rating						
	$\beta_x \geq 100$	β_3	β_6	β_{10}	β_{12}	β_{20}	β_{25}
05Q	6	12 91.7	≥ 100 99.0	>1000 99.9	>2000 99.95	>5000 99.98	INF
10Q	10	8 87.5	22 95.4	≥ 100 99.0	≥ 200 99.5	>5000 99.98	INF
20Q	20	-	2 50.0	8 87.5	20 95.0	≥ 100 99.0	>200 99.5

Element Beta ratio β_x
Element efficiency in percent*

100P Series

Parts List

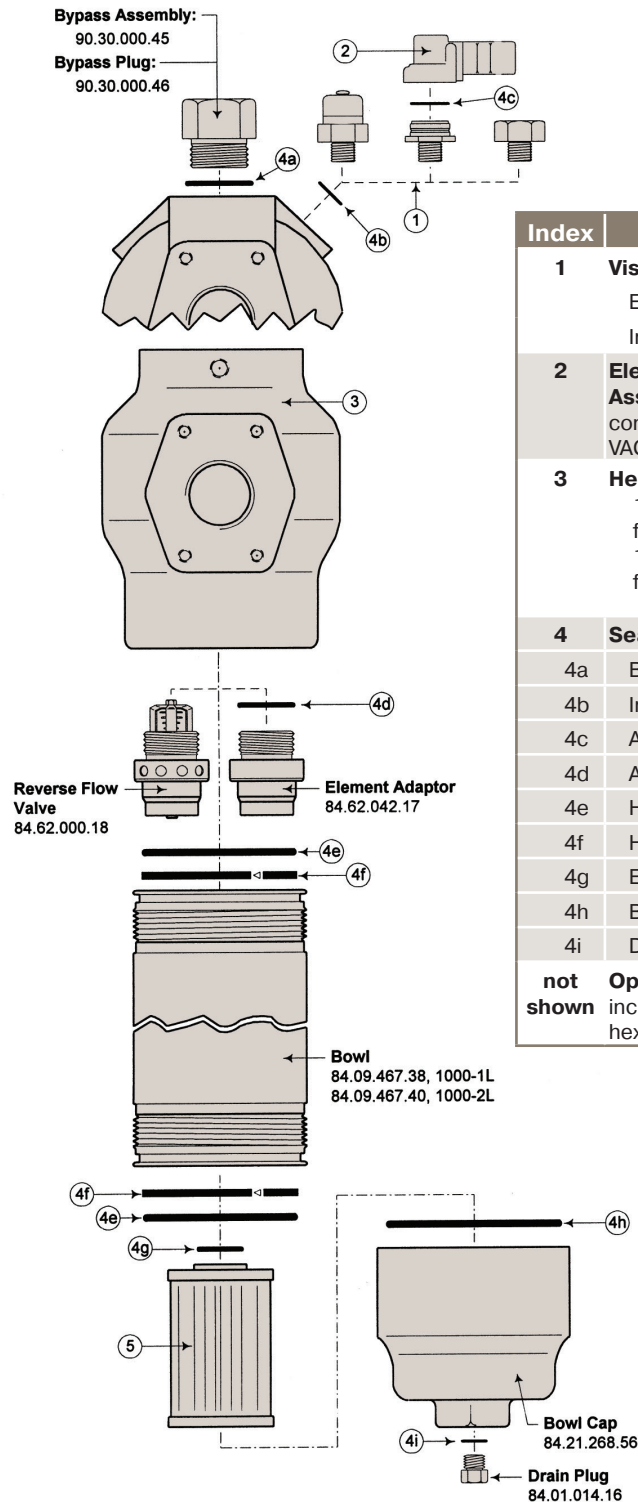

Index	Description	Part Number	
1	Visual Indicator	6N50-2A	
	Electrical Sub-Assy	90.34.000.24	
	Indicator Plug	84.01.066.30	
2	Electrical Actuator Assembly , Hirschmann connector, E2, 28 VDC, 250 VAC max.	FF3468	
3	Head		
	1000-F, 1 1/22 SAE 6000 psi flange Code 62	84.69.268.20	
	1000-T, 22 SAE 6000 psi flange, code 62	84.69.268.22	
4	Seals	Nitrile	Flourocarbon
4a	Bypass assembly/ Plug seal*	N93924	V93924
4b	Indicator to Head seal*	N72019	V72019
4c	Actuator dust seal	N72012	
4d	Adapter to head seal*	81.10.150.15	81.10.152.15
4e	Head/Bowl/Cap seal*	N92346	V92346
4f	Head to bowl back-up ring	FF3142	
4g	Element seal	N72141	V72141
4h	Bowl cap seal*	81.10.150.86	81.10.152.86
4i	Drain plug seal*	N93906	V93906
not shown	Optional Mounting bracket , includes (2) 5/8"-11 x 1 1/4" hex flange bolts	402904	

*Included in Seal Kit: **936063**, Nitrile

Drawings are for reference only.
Contact factory for current version.

100P Series¹

High Pressure Filters

How To Order

Select the desired symbol (in the correct position) to construct a model code. Example:

BOX 1	BOX 2	BOX 3	BOX 4	BOX 5	BOX 6	BOX 7	BOX 8
100P	2	10Q	B	M2	M	F32	1

BOX 1: Filter Series	
Symbol	Description
100P	High Pressure Filter

BOX 2: Element Length	
Symbol	Description
2	Double

BOX 3: Media Code	
Symbol	Description
Standard Element	
05Q	Microglass, 5 micron
10Q	Microglass, 10 micron
20Q	Microglass, 20 micron

BOX 4: Seals	
Symbol	Description
B	Nitrile
V	Fluorocarbon

BOX 5: Indicators ²	
Symbol	Description
M2	Visual Differential
E2	Electrical Differential

BOX 6: Bypass & Indicator Setting	
Symbol	Description
M	100 psid (7 bar)

BOX 7: Ports	
Symbol	Description
F24	1 1/2" SAE flange, Code 62
F32	2" SAE flange, Code 62

BOX 8: Options	
Symbol	Description
1	None
3	Reverse flow valve (RFV)

Notes:

- Filters include the element you select already installed.
- Indicator setting is 73 psid (5.0 bar).

Replacement Elements (Nitrile*)

Standard Collapse	
Media	Single
02Q	939064Q
05Q	939065Q
10Q	939066Q
20Q	939067Q

*Note: Consult factory for fluorocarbon elements.

