

IQAN-TOC2

Instruction book

Publ no HY33-8300-IB/UK
Edition August, 2009

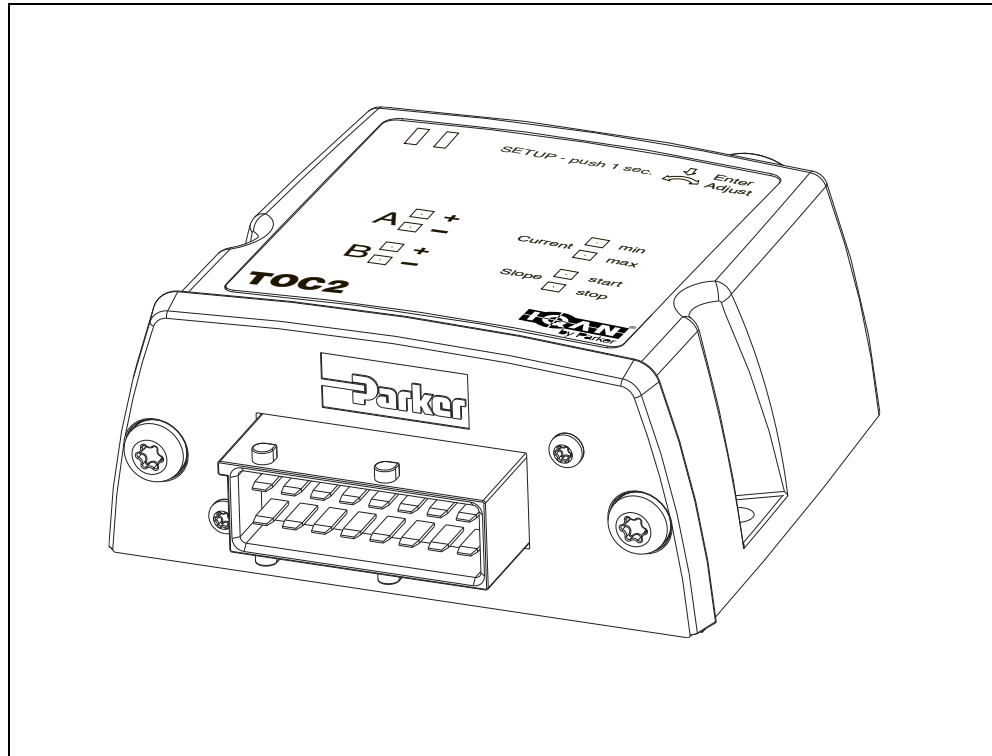

| | | |
|----------|------------------------------------|-----------|
| 1 | Introduction | 1 |
| | Safety symbols | 1 |
| 2 | Precautions | 2 |
| | General safety regulations | 2 |
| 3 | Product description | 4 |
| | IQAN-TOC2 | 4 |
| | Safety | 8 |
| | | 8 |
| | System Diagnosis | 10 |
| 5 | Mounting | 11 |
| | Mounting the unit | 11 |
| 6 | Installation | 12 |
| | Connector C1 | 12 |
| | Supply voltage | 13 |
| | RS232 connection | 14 |
| | Reference voltage, VREF | 14 |
| | Voltage inputs | 15 |
| | Proportional outputs | 20 |
| | HMI Human Machine Interface | 21 |
| 7 | Start-up | 25 |
| | Start-up procedures | 25 |
| | Appendix A | 27 |
| | IQAN-TOC2 Technical Overview | 27 |
| | Appendix B | 30 |
| | Appendix C | 31 |

1 Introduction

These instructions are meant as a reference tool for the vehicle manufacturer's design, production, and service personnel.

The user of this manual should have basic knowledge in the handling of electronic equipment.

Safety symbols

Sections regarding safety, marked with a symbol in the left margin, must be read and understood by everyone using the system, carrying out service work or making changes to hardware and software.

The different safety levels used in this manual are defined below.



WARNING

Sections marked with a warning symbol in the left margin, indicate that a hazardous situation exists. If precautions are not taken, this could result in death, serious injury or major property damage.



CAUTION

Sections marked with a caution symbol in the left margin, indicate that a potentially hazardous situation exists. If precautions are not taken, this could result in minor injury or property damage.



NOTICE

Sections marked with a notice symbol in the left margin, indicate there is important information about the product. Ignoring this could result in damage to the product.

Contact the manufacturer if there is anything you are not sure about or if you have any questions regarding the product and its handling or maintenance.

The term "manufacturer" refers to Parker Hannifin Corporation.

2 Precautions

General safety regulations

Work on the hydraulics control electronics may only be carried out by trained personnel who are well-acquainted with the control system, the machine and its safety regulations.



WARNING

Mounting, modification, repair and maintenance must be carried out in accordance with the manufacturer's regulations. The manufacturer has no responsibility for any accidents caused by incorrectly mounted or incorrectly maintained equipment. The manufacturer does not assume any responsibility for the system being incorrectly applied, or the system being programmed in a manner that jeopardizes safety.



WARNING

Damaged product may not be used. If the control system shows error functions or if electronic modules, cabling or connectors are damaged, the system shall not be used.



WARNING

Electronic control systems in an inappropriate installation and in combination with strong electromagnetic interference fields can, in extreme cases, cause an unintentional change of speed of the output function.



NOTICE

As much as possible of the welding work on the chassis should be done before the installation of the system. If welding has to be done afterwards, the electrical connections on the system must be disconnected from other equipment. The negative cable must always be disconnected from the battery before disconnecting the positive cable. The ground wire of the welder shall be positioned as close as possible to the place of the welding. The cables on the welding unit shall never be placed near the electrical wires of the control system.

Construction regulations



CAUTION

The vehicle must be equipped with an emergency stop which disconnects the supply voltage to the control system's electrical units. The emergency stop must be easily accessible to the operator. The machine must be built if possible, so that the supply voltage to the control system's electrical units is disconnected when the operator leaves the operator's station.

Safety during installation



CAUTION

Incorrectly positioned or mounted cabling can be influenced by radio signals which can interfere with the functions of the system.

Safety during start-up



WARNING

The machine's engine must not be started before the control system is mounted and its electrical functions have been verified.

Ensure that no one is in front, behind or nearby the machine when first starting up the machine.

Follow the instructions for function control in the Start-up section.

Safety during maintenance and fault diagnosis



CAUTION

Ensure that the following requirements are fulfilled before any work is carried out on the hydraulics control electronics.

- The machine cannot start moving.
- Functions are positioned safely.
- The machine is turned off.
- The hydraulic system is relieved from any pressure.
- Supply voltage to the control electronics is disconnected.

3 Product description

IQAN-TOC2

The IQAN-TOC2 is a stand alone controller designed for controlling hydraulic systems in vehicles and machinery, using 12/24 Vdc power supply.

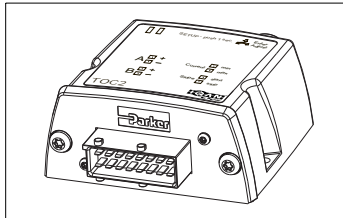

The IQAN-TOC2 control.

Input

The IQAN-TOC2 control has four(4) inputs. Two are used as *voltage inputs* for connection of 0-5 Vdc signals, VIN A and VIN B. When two control devices (i.e. joysticks) are connected to VIN A and VIN B respectively, the IQAN-TOC2 can operate up to two directional valve sections.

The other two inputs are *digital inputs*, DIN A and DIN B. The digital inputs may be used in a variety of ways (ie 'output enable' switch).

All inputs, *voltage* or *digital*, may be configured using IQANdevelop software.

Output

The IQAN-TOC2 control has two (2) double *proportional outputs* for controlling proportional valves or devices. The unit can control two directional valve sections or two independent single solenoid devices (ie. proportional cartridge valves). The outputs can be used in two different modes. Either *Current mode* (current closed loop) or *PWM mode* (voltage open loop) signals can be selected and the parameters configured using IQAN software.

In order to increase the performance of the proportional outputs when controlling directional valves, the *frequency* can be adjusted using IQANdevelop software.

The *min. output*, *max. output* and *start/stop slopes* are adjustable from the mechanical HMI (human machine interface) and also with IQANdevelop software.

Output derating in high temperatures

This diagram shows the IQAN-TOC2 output current derating when the unit is working in high ambient temperatures. Due to internal power dissipation the temperature inside the enclosure will be higher than the ambient air. Maximum current in low temperatures are mainly restricted by the software. The graph below shows the relation between high ambient temperature and total output current (the sum of *COUT-A* and *COUT-B*).

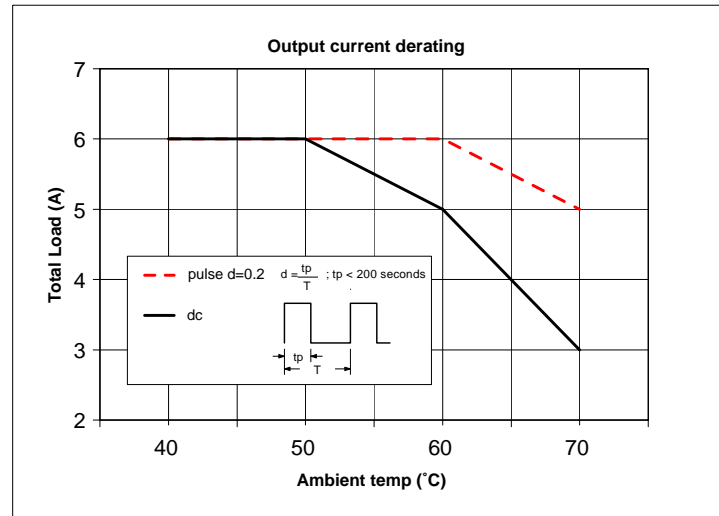

Current derating for the IQAN-TOC2 control.

Frequency

To obtain the best performance from proportional valves the IQAN-TOC2 produces a current mode (closed loop) output signal or a PWM voltage (open loop) output signal. The type of output is selectable in IQAN software. The unit has an adjustable frequency which can be changed using IQAN software.

The following table shows the IQAN-TOC2 frequency possibilities. Any frequency may be entered in your application and is translated according to this table. The bold values are the actual frequencies in Hz output by the IQAN-TOC2 for proportional valve control.

| Frequency (Hz) entered in appl. | Frequency (Hz) output by IQAN-TOC2 | Frequency (Hz) entered in appl. | Frequency (Hz) output by IQAN-TOC2 |
|---------------------------------|------------------------------------|---------------------------------|------------------------------------|
| 25 | 25 | 50-52 | 50 |
| 26 | 26 | 53-55 | 53 |
| 27 | 27 | 56-58 | 56 |
| 28 | 28 | 59-62 | 59 |
| 29 | 29 | 63-66 | 63 |
| 30 | 30 | 67-70 | 67 |
| 31 | 31 | 71-76 | 71 |
| 32 | 32 | 77-82 | 77 |
| 33 | 33 | 83-90 | 83 |
| 34-35 | 34 | 91-99 | 91 |
| 36 | 36 | 100-110 | 100 |
| 37 | 37 | 111-124 | 111 |
| 38-39 | 38 | 125-142 | 125 |
| 40-41 | 40 | 143-166 | 143 |
| 42 | 42 | 167-199 | 167 |
| 43-44 | 43 | 200-249 | 200 |
| 45-47 | 45 | 250-332 | 250 |
| 48-49 | 48 | 333+ | 333 |

Table showing possible output frequencies.

RS232 serial communication

Through the RS232 interface it is possible to set and read information stored in the IQAN-TOC2 using IQANdevelop software.

The serial interface is used for the following:

- Downloading a new vmAC (.ido filetype).
- Downloading a new application (.idt filetype).
- Reading or changing stored parameters.
- Reading or clearing error and status counters.

VREF external voltage reference

Voltage reference VREF will supply external sensors and levers with +5V on the +VREF pin. The return line from each sensor or lever is connected to the -VREF pin.

The +VREF signal is protected against short circuit to +BAT, -BAT and short circuit of load. The +VREF output has error detection and if the signal is out of range an error will be activated. During error situations all voltage inputs (VIN A and VIN B) are forced to the pre-defined error value specified in IQANdevelop.

The -VREF signal is not protected against short circuit to +BAT. This failure mode can cause high current that will destroy the module.



NOTICE

Maximum load for the VREF, see Appendix A, on page 27.

4 Safety

General

In order to fulfill safety demands, the IQAN-TOC2 control memory is checked through check-sum calculations at startup. Memory errors always lead to an immediate shut off of all outputs and the software goes to a failsafe state.

Input/output Protection

All inputs on the IQAN-TOC2 control are designed to withstand the maximum specified supply voltage. VIN out of range will generate an error code. DIN errors are not monitored but overvoltage will not affect the other inputs. The outputs are protected against short circuit.

Current mode output

For the *current mode outputs*, a current check is performed. If an error occurs, the user will be notified through an appropriate error code on the unit's LED.

PWM mode output

For the *PWM mode outputs*, no error checking is performed.

Memory test

At startup the IQAN-TOC2 vmAC calculates the checksum of the application (stored in Flash) and the checksum of adjustable parameters (stored in E2prom). If any of these checksums fail, I/O handling will not be allowed, and an error message will be transmitted by the diagnostic lamp. This checksum control will only be performed at startup.

Failure Modes

| Type of failure | Comments |
|--------------------------------|---|
| VREF | |
| +VREF open | VIN out of range, will create a VIN error => VIN=Predefined error value |
| -VREF open | VIN out of range, will create a VIN error => VIN=Predefined error value |
| +VREF short-circuited to -VREF | VREF error, will shut off outputs |
| +VREF short-circuited to +BAT | VREF error, will shut off outputs |
| +VREF short-circuited to -BAT | VREF error, will shut off outputs |
| -VREF short-circuited to +BAT | External fuse (max 7.5A) on +BAT blows |
| -VREF short-circuited to -BAT | not detected |
| VIN | |
| VIN open | VIN out of range, will create a VIN error => VIN=Predefined error value |
| VIN short-circuited to +BAT | VIN out of range, will create a VIN error => VIN=Predefined error value |
| VIN short-circuited to -BAT | VIN out of range, will create a VIN error => VIN=Predefined error value |

| Type of failure | Comments |
|---|---|
| DIN | |
| DIN open | not detected |
| DIN short-circuited to +BAT | not detected |
| DIN short-circuited to -BAT | not detected |
| Current mode | |
| COUT open | COUT error will shut off output |
| CRET (active) open | COUT error will shut off output |
| CRET (passive) open | not detected, will not affect function |
| COUT short-circuited to CRET (active) | COUT error will shut off output |
| COUT short-circuited to CRET (passive) | not detected, will not affect function |
| COUT short-circuited to +BAT | COUT error will shut off output |
| COUT short-circuited to -BAT | COUT error will shut off output |
| CRET (active) short-circuited to +BAT | COUT error will shut off output |
| CRET (active) short-circuited to -BAT | COUT error will shut off output |
| CRET (passive) short-circuited to +BAT | not detected, will not affect function |
| CRET (passive) short-circuited to -BAT | not detected, will not affect function |
| COUT short-circuited to 2nd COUT (active) | COUT error on one of the outputs (indeterministic function) |
| COUT short-circuited to 2nd COUT (passive) | not detected, will not affect function |
| COUT short-circuited to 2nd CRET (active) | COUT error will shut off output |
| COUT short-circuited to 2nd CRET (passive) | not detected, will not affect function |
| CRET short-circuited to 2nd CRET (active) | COUT error will shut off output |
| CRET short-circuited to 2nd CRET (passive) | not detected, will not affect function |
| Insufficient voltage | COUT error will shut off output |
| H-side short-circuited to 2nd H-side (active) | |

System Diagnosis

The yellow blinking LED on the top of the unit indicates normal status. The IQAN-TOC2 control indicates *error status* through the red blinking LED and a yellow secondary blinking pattern, as shown below.

This gives an immediate indication as to the cause of an error.

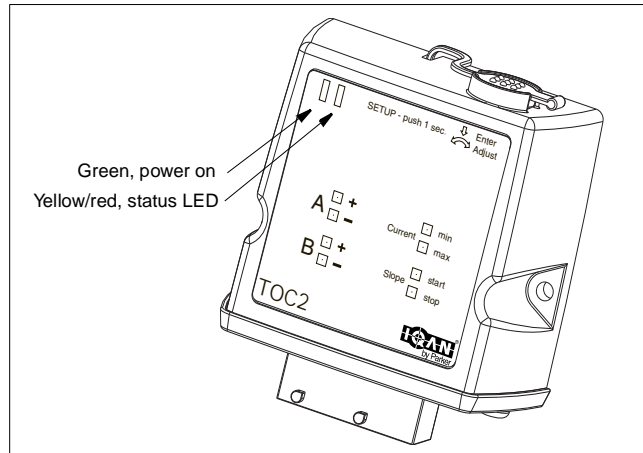

The location of the LED indicators on the IQAN-TOC2 control.

The green LED indicates power on. The yellow/red LED, will be blinking a pattern when an error has been detected or during certain operations. To get further information about the error messages, see Appendix B, on page 30.

5 Mounting

Mounting the unit

The IQAN-TOC2 control should be mounted according to the following instructions:

- Locate the unit eliminating the risk for the cabling to be folded, crushed or damaged in any way. Ensure the cabling cannot pull, twist or induce sload on the connector.
- Locate the unit so that severe physical impact is avoided, e.g impact from falling objects or the unit being used as a step.
- Locate the unit so that air can circulate to eliminate excess heat. Ensure that no external heat, e.g. from the engine or heater, is transferred to the control.
- Locate the unit to protect it from high pressure washing or similar.
- Locate the unit so that the cable connector is facing down .
- Locate the unit so that the HMI is accessible.
- Locate the unit so that the LEDs are visible.

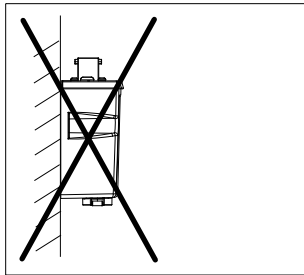

Non-approved placing.

The rubber cap covering the HMI adjustment access hole must always be replaced to protect the unit.

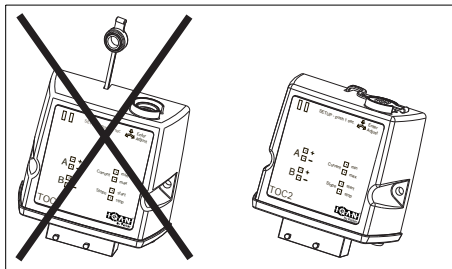

Always replace the rubber cap.

6 Installation

Connector C1

| | |
|------------------------|---------------------------|
| Connector kit | Parker no. 5031105 |
| Housing | Amp no. 1-963217-1 |
| Plane sealing, 16 pos. | Amp no. 963216-1 |
| Pin type | Amp no. 929939-1 |
| Cables | 0,75-1,0 mm ² |
| Seals | Amp no. 828904-1 |
| Plugs (empty pos.) | Amp no. 828922 |
| IQAN toolkit | Parker no. 5031061 |

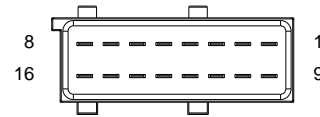

The IQAN tool kit description is found in the 'IQAN accessories' datasheet.

| Pos | Signal name | Pos | Signal name |
|-----|-----------------|-----|-------------|
| 1 | +BAT (12V, 24V) | 9 | -BAT |
| 2 | CRET-A+ | 10 | CRET-B+ |
| 3 | CRET-A- | 11 | CRET-B- |
| 4 | COUT-A | 12 | COUT-B |
| 5 | DATA-OUT | 13 | DATA-IN |
| 6 | DIN-A | 14 | DIN-B |
| 7 | +VREF | 15 | -VREF |
| 8 | VIN-A | 16 | VIN-B |

Supply voltage

Before any installation of the IQAN system can take place, make sure the ignition lock is turned off and the battery is disconnected.

Emergency stop

Make sure an *Emergency Stop* disconnecting the power supply, is easily accessible at any time. Further relevant regulations are to be found in Machinery Directives 9837/EC. The figure below shows how to connect the emergency stop.

Connecting of Supply Voltage

The supply voltage, should be within the operating interval, see Appendix A, on page 27. Connect the supply voltage to +BAT, position 1 and -BAT, position 9. Reverse voltage protection for the control is provided by using a fuse. Requisite fuse level should be 7,5 A.

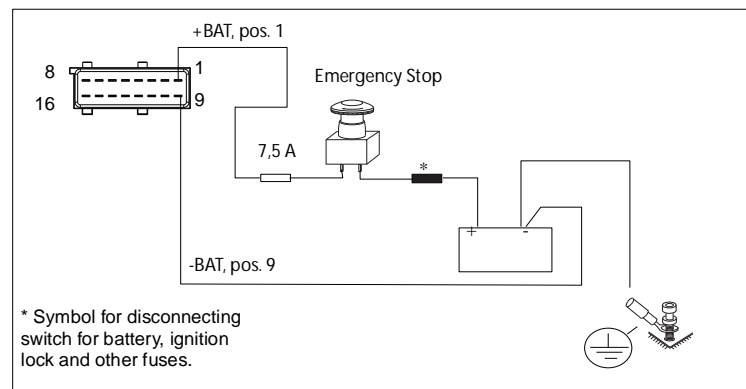

Connecting the emergency stop and voltage supply.



NOTICE

Do not use the chassis as the negative terminal.

RS232 connection

The IQAN-TOC2 control has an *RS232 interface* for communicating with the programming software, IQANdevelop. A flying lead cable, 5030089 may be connected to the IQAN-TOC2 to provide an HR12 connector interface. The connection from IQAN-TOC2 to PC can be made with cable 5030024 and from IQAN-TOC2 to PalmOS PDA with the cable 5030096.

Instead of Parker cable 5030089, the recommended wiring to a Hirose HR12 series receptacle is shown below.

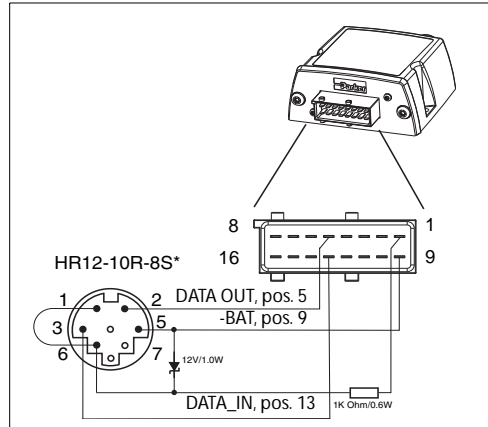

Connecting for RS232.



NOTICE

The 'PDA Diagnostic cable' 5030096 must be used when connecting a PalmOS PDA (Tungsten T3 or earlier models) to the IQAN-TOC2. The palmtop device will also need its hot-sync cable.

Use of the 'MDM RS232 cable' 5030024 may damage older palmtop devices.

Reference voltage, VREF

The IQAN-TOC2 control is internally equipped with a voltage regulator to generate the reference voltage *VREF*. This reference voltage will feed different kinds of joysticks, potentiometers or sensors.

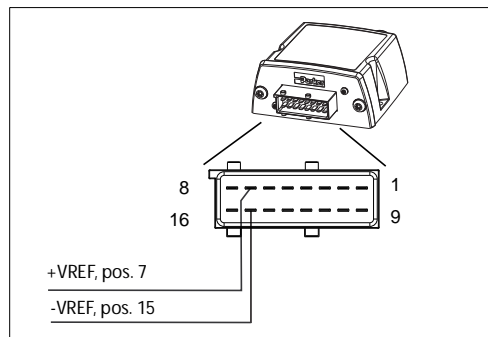

VREF position.



NOTICE

Maximum load for the VREF is different according to 12/24 Vdc power supply, see Appendix A, on page 27.

Voltage inputs

Connecting joysticks to the voltage inputs

The joystick output range must be within 0-5 Vdc. To detect signal errors such as short circuits or interruptions the active signal range should be within 0.5-4.5 Vdc.

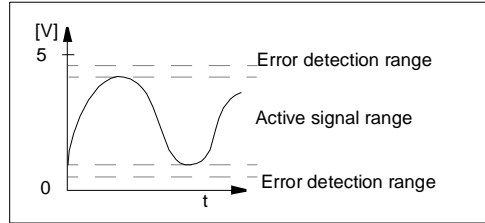

Active signal range.

The connection examples are based on the factory default application.

Connecting a single output joystick to voltage in

The positive terminal of the joystick is connected to the +VREF position and the corresponding negative terminal to the -VREF position. The joystick output signal is connected to the appropriate VIN position. DIN-A is connected to the DOUT signal from an 'operator present' switch or to +BAT. DIN-B is connected to +BAT.

EXAMPLE

Connect the positive and negative terminals of the joystick to +VREF, position 7, and -VREF, position 15, respectively.

Connect the joystick 0.5-4.5V output signal to VIN-A, position 8 and DOUT or +BAT to DIN-A, position 6. Connect +BAT to DIN-B, position 14.

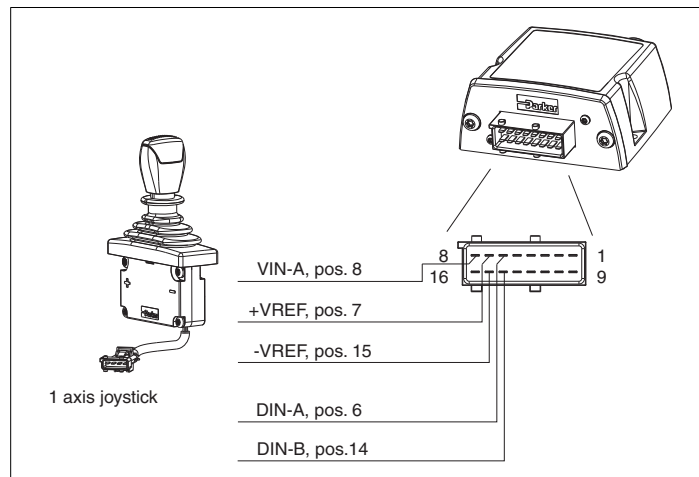

Connecting VREF and joystick signal VIN-A.



NOTICE

The negative terminal of the joystick must not be connected to the chassis. Maximum load for the VREF position, see Appendix A, on page 27.

Connecting two single output joysticks to voltage in

When you connect two joysticks to the IQAN-TOC2, you will use both VIN A and VIN B input signals. Output A will be controlled by the joystick output connected to VIN A and Output B will be controlled by the joystick output connected to VIN B. Two valve sections can be controlled when using two single output joysticks.

The positive terminal of each joystick is connected to the +VREF position and the corresponding negative terminal is connected to the -VREF position. The joystick output signals are connected to the appropriate VIN positions. DIN-A is connected to the paralleled DOUT signals from the joystick 'operator present' switches or to +BAT. DIN-B is connected to +BAT

EXAMPLE

Connect the positive and negative terminals of each joystick to +VREF, position 7, and -VREF, position 15, respectively. Then connect the first joystick 0.5-4.5V output signal to VIN-A, position 8 and connect the second joystick 0.5-4.5V output signal to VIN-B, position 16. Connect the DOUT's or +BAT to DIN-A, position 6. and connect +BAT to DIN-B, position 14.

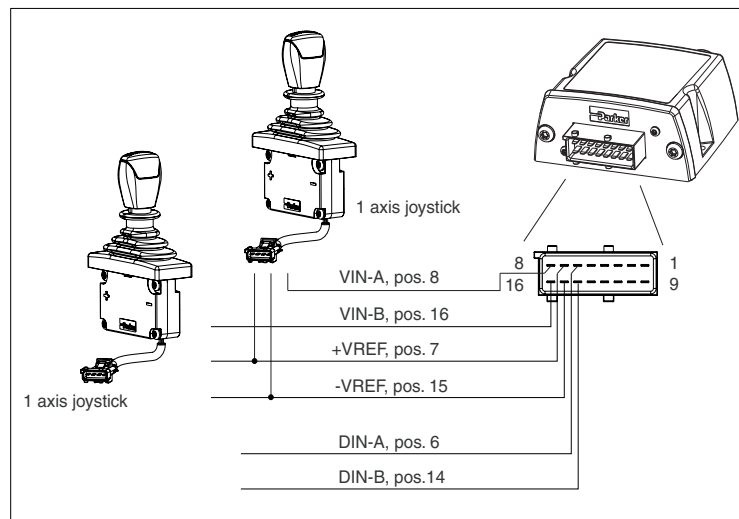

Connecting VREF and two joystick signals to VIN-A and VIN-B.



NOTICE

The negative terminals of the joysticks must not be connected to the chassis. Maximum load for the VREF position, see Appendix A, on page 27.

Connecting a two axis joystick to voltage in

When you connect a two axis joystick to the IQAN-TOC2, you will use both VIN A and VIN B input signals. Output A will be controlled by the joystick output connected to VIN A and Output B will be controlled by the joystick output connected to VIN B. Two valve sections can be controlled when using a two axis joystick.

The Parker ICL4 and ICM4 joysticks do not use the +VREF position or the -VREF position. Power supply to this type of joystick is from +BAT and -BAT. The joystick output signals are connected to the appropriate VIN position. DIN-A is connected to the DOUT signal from an 'operator present' switch or to +NPO. DIN-B is connected to +BAT

EXAMPLE

Connect the positive and negative terminals of the joystick to +BAT and -BAT respectively. See installation sheet 9129 8323 02.

Connect the first axis 0.5-4.5V output signal to VIN-A, position 8 and connect the second axis 0.5-4.5V output signal to VIN-B, position 16. Connect the DOUT or +NPO to DIN-A, position 6 and connect +BAT to DIN-B, position 14.

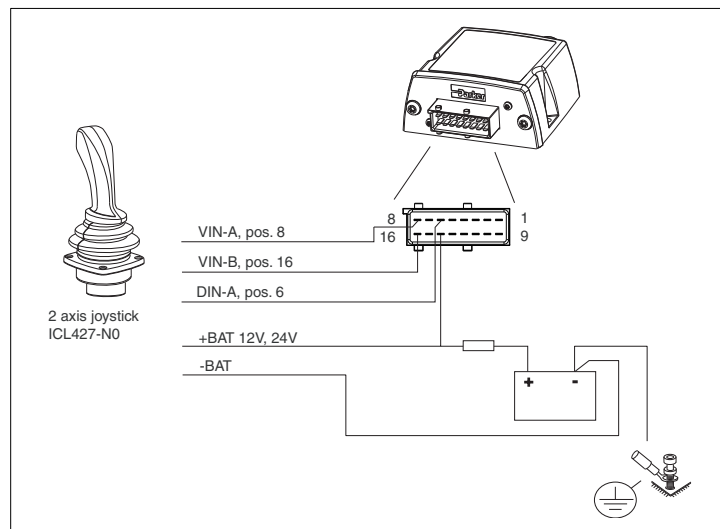

Connecting dual axis joystick signals to VIN-A and VIN-B.

Connecting a single axis, dual output joystick to voltage in

You would connect a dual output joystick for the highest degree of safety. Since this type of joystick uses error checking, you use both VIN-A and VIN-B input signals. The second output from the joystick is inverted (4,5V - 0,5V). Only a single valve section can be controlled when using a dual output joystick.

The positive terminal of the joystick is connected to the +VREF position and the corresponding negative terminal is connected to the -VREF position. The joystick output signals are connected to the appropriate VIN position. DIN-A is connected to the DOUT signal from an 'operator present' switch or to +BAT..

EXAMPLE

Connect the positive and negative terminals of the joystick to +VREF, position 7, and -VREF, position 15, respectively.

Then connect the joystick output A signal to VIN-A, position 8 and connect the joystick output B signal to VIN-B, position 16. Connect DOUT or +BAT to DIN-A, position 6.

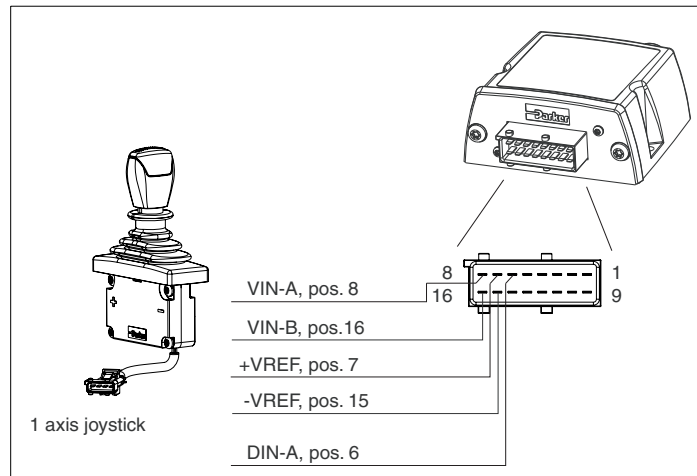

Connecting VREF and dual output joystick signals to VIN-A and VIN-B.



NOTICE

The negative terminal of the joystick must not be connected to the chassis. Maximum load for each VREF position, see Appendix A, on page 27.

Connecting potentiometers to the voltage inputs

Potentiometers could be connected to the voltage inputs, to provide a rotary control to generate the input signal. The potentiometer may be connected to +VREF, VIN and -VREF respectively. DIN-A is connected to the DOUT signal from an 'operator present' switch (ie. footswitch or seat switch) or to +BAT. DIN-B is connected to +BAT.

EXAMPLE

Connect the positive and negative terminals of the pot to +VREF, position 7 and -VREF, position 15 respectively. Connect the output (or wiper) to VIN-A, position 8 and DOUT or +BAT to DIN-A, position 6. Connect +BAT to DIN-B, position 14.

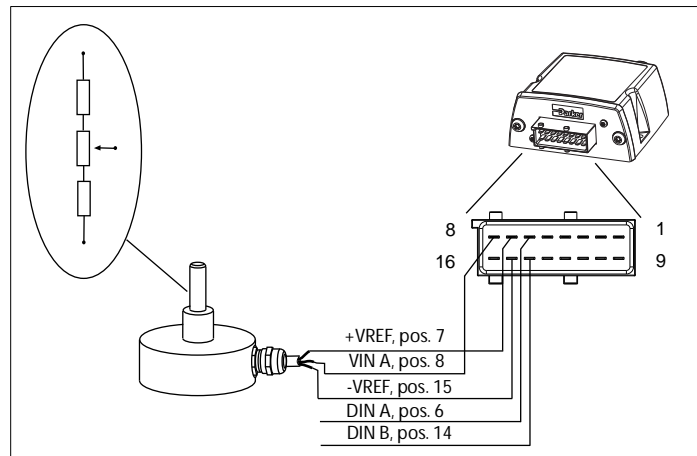

Connecting a pot to VIN-A.



NOTICE

Maximum load for VREF, see Appendix A, on page 27.

Proportional outputs

The current /PWM outputs control proportional valves and devices. Maximum load should not exceed 150 W. For the current range see Appendix A, on page 27.

Frequency

To obtain the best performance from proportional valves the control produces a current mode (closed loop) output signal or a PWM voltage (open loop) output signal. The type of output is selectable in IQANdevelop. The units have an adjustable frequency which can be changed using IQANdevelop.

Connecting loads to proportional outputs

Connecting a load, e.g. one proportional valve section, to the current mode or PWM mode outputs is done by using the COUT/CRET pair positions.

EXAMPLE

Positive direction:

Connect the proportional valve to the COUT-A, position 4 and the CRET-A+, position 2 respectively.

Negative direction:

Connect the proportional valve to the COUT-A, position 4 and CRET-A- , position 3 respectively.

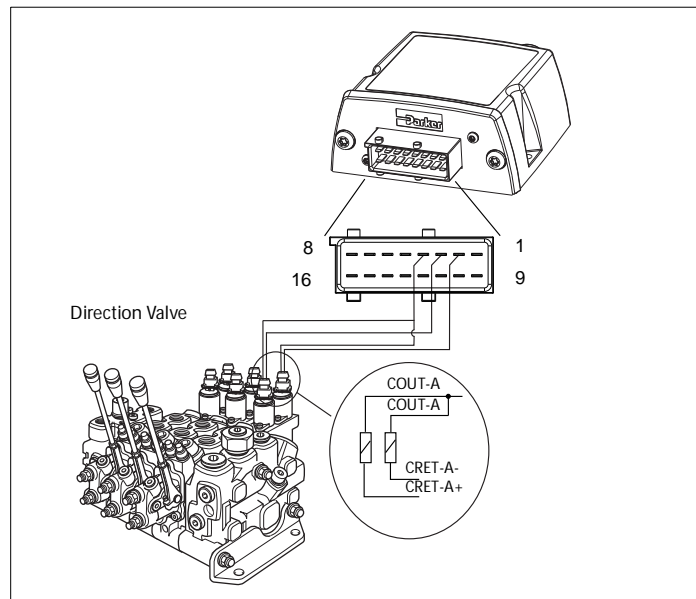

Connecting a load to proportional output COUT A.



NOTICE

Do not install diodes across coils for Current or PWM modes!
Do not exceed 150 W load on outputs.

HMI Human Machine Interface

The IQAN-TOC2 control has a mechanical interface for adjusting the min., max. and ramp properties of the outputs. Only properties that are set as adjustable in the application can be adjusted.

Access to the mechanical encoder is shown below.

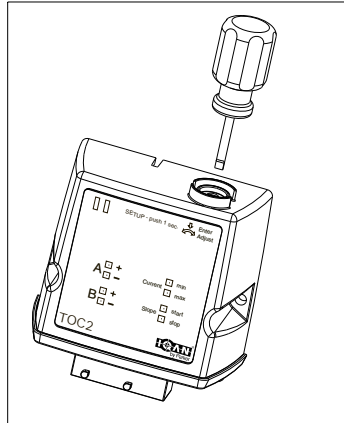

Location of IQAN-TOC2 HMI.

The adjustment mode is entered by pressing the pushbutton for more than 1 second. The unit will then wait for an output to be activated by the user (auto-select). After the user confirms the output selection by a click on the pushbutton, all adjustments will be done on the selected output. During adjustment all other outputs work normally to make fine tuning of a function easier. When adjustments are completed the pushbutton is pressed for a longer period (>1 second) and the unit will change back to operating mode

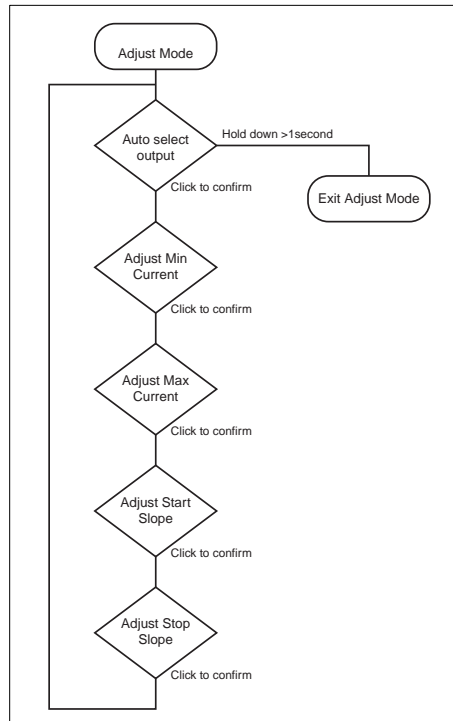

Flowchart for adjustment procedure on IQAN-TOC2.

Adjustment procedure

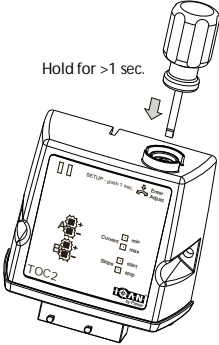
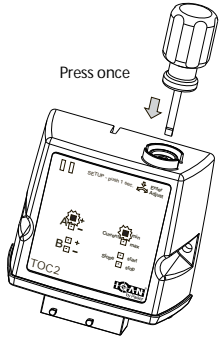
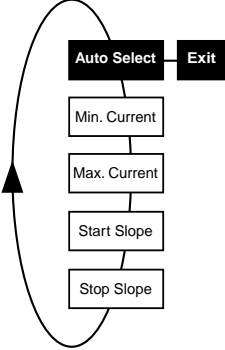
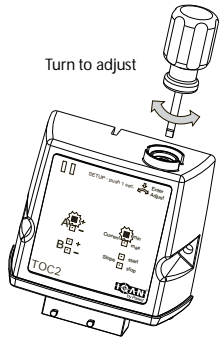
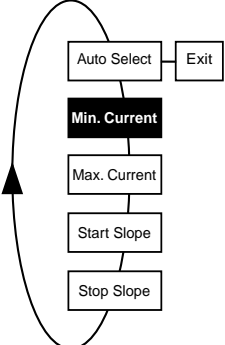
| Action at IQAN-TOC2 | Description | Mode |
|--|---|---|
|  <p>Hold for >1 sec.</p> | <p>The IQAN-TOC2 must be connected to +BAT before adjusting.</p> <p>Remove the protective rubber cap to access HMI.</p> <p>Using a small screwdriver, press the slotted pushbutton shaft and hold for more than one second.</p> <p>This enters adjustment mode. The A and B +/- LED's will flash to show the unit is in adjustment mode.</p> | |
|  <p>Press once</p> | <p>Activate the control (lever, joystick, potentiometer...) for the function you want to adjust in order to auto-select. The LED for the proper channel and direction will flash at the IQAN-TOC2.</p> <p>Press the pushbutton to confirm your selection. The flashing LED will change to a steady on state and the min current LED for the selected channel will light.</p> |  |
|  <p>Turn to adjust</p> | <p>To change the min current setting, use your screwdriver to turn the slotted shaft. Activate your control (lever, joystick, potentiometer...). When adjusting the min value the selected function is not allowed to exceed the min setting, regardless of the control position. Turning the shaft clockwise will increase the min current and counter-clockwise will reduce the min current.</p> |  |

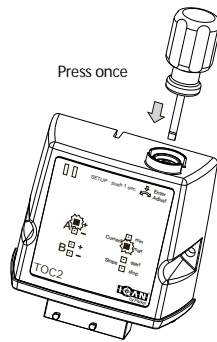

When you are finished adjusting the min current or if you do not need to adjust the value, you may press the pushbutton to go on to the next step. The max current LED for the selected channel will light.

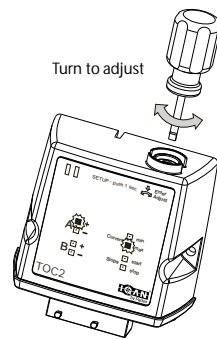

To change the **max current** setting, use your screwdriver to turn the slotted shaft. Activate your control (lever, joystick, potentiometer...). When adjusting the max value the selected function is allowed to move at the max setting and the min current setting is active. Turning the shaft clockwise will increase the max current and counter-clockwise will reduce the max current.

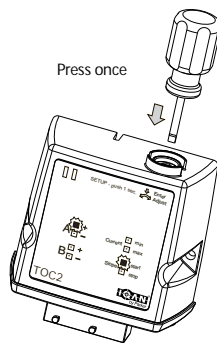
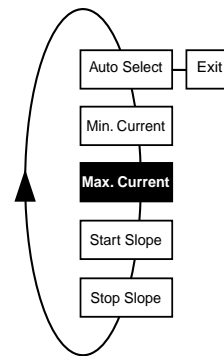

When you are finished adjusting the max current or if you do not need to adjust the value, you may press the pushbutton to go on to the next step. The start slope LED for the selected channel will light.

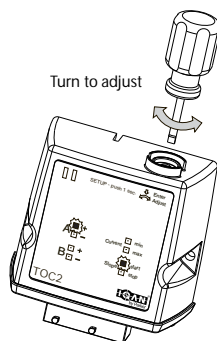

To adjust the **start slope** setting, use your screwdriver to turn the slotted shaft. When adjusting the start slope the function is allowed to move at the max setting and the min current setting is active. Turning the shaft clockwise will increase the start slope time and counter-clockwise will reduce the start slope time. Activate your control to check the start slope after each adjustment.

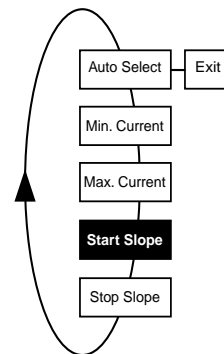

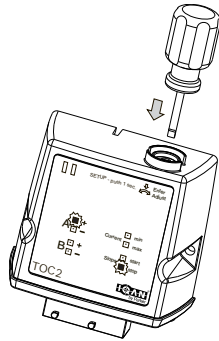

When you are finished adjusting the start slope or if you do not need to adjust the value, you may press the pushbutton to go on to the next step. The stop slope LED for the selected channel will light.

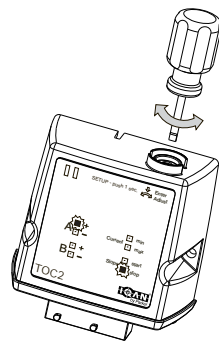

To adjust the **stop slope** setting, use your screwdriver to turn the slotted shaft. When adjusting the stop slope the function is allowed to move at the max setting and the min current setting is active. Turning the shaft clockwise will increase the stop slope time and counter-clockwise will reduce the stop slope time. Activate your control to check the stop slope after each adjustment.

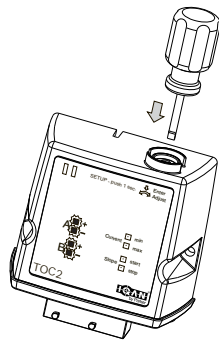
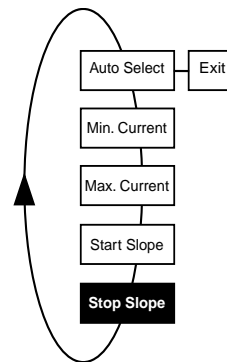

When you are finished adjusting the stop slope or if you do not need to adjust the value, you may press the pushbutton to go on to the next step. This was the last adjustment for the selected channel and direction, so the A and B +/- LED's will flash once more to show that the unit is in adjustment mode

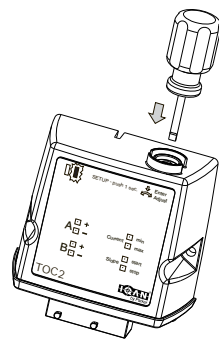

To adjust a new channel or direction, activate the control for the function you want to adjust in order to auto-select. Then repeat the adjustment steps. If adjustment is complete, press the slotted pushbutton shaft and hold for more than one second. This exits adjustment mode. You may only exit adjustment mode from the Auto Select step. Be sure to replace the protective rubber cap.

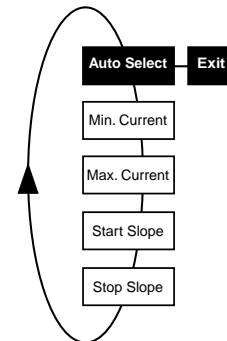

7 Start-up

Start-up procedures

This chapter contains instructions for action to be taken in connection with the initial start, for example, setting values, calibrating and testing the system.



WARNING

Risk of injury!

If the control system is not fitted properly, the machine could move uncontrollably. The machine's engine shall not be started before the control system is completely fitted and its signals are verified.

Starting the control system

Start the control system as follows:

- Prior to start, the control and cables are to be fitted correctly.
- Check fuses, i.e. make sure that the supply voltage to the unit is equipped with the correct fuse.
- Make sure that connections for supply voltage and return lines are correct in the cable's conductor joint.
- Make sure the emergency stop works.
The emergency stop should disconnect the supply voltage to the control.

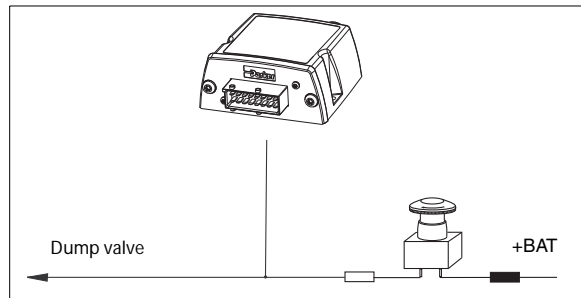

Emergency stop.

Alternatively, the emergency stop may also shut off the diesel engine or a dump valve, and depressurize the hydraulic system.

Prepare for system start



WARNING

Make sure no one is in dangerous proximity to the vehicle, to avoid injuries when it starts.

Prepare for the initial system start as follows:

- The engine for the hydraulic system's pump shall be in off position.
- Make sure that all connectors are properly connected.
- Turn on the control system.
- Make sure that voltage is being supplied to the control, the green diode will be illuminated on the unit.
- Make sure the emergency stop is functioning properly.

Start the system

Start the system as follows:

- Start the engine for the hydraulic system's pump, assuming that the above mentioned inspections have been carried out and shown correct values.
- Calibrate and adjust input and output signals according to the instructions and check every output function carefully.
- In addition to these measures, the machine shall also meet the machine directives for the country in question.

Appendix A

IQAN-TOC2 Technical Overview

Absolute maximum ratings

$T_A = +25\text{ °C}$ (unless otherwise specified)

| Parameter | Limit values | | | Unit | Remark |
|--------------------------------------|--------------|------|------|------|--|
| | min. | typ. | max. | | |
| Operating ambient temperature, T_A | - 40 | | +70 | °C | |
| Storage temperature | - 40 | | +100 | | |
| Voltage supply, V_{BAT} | 6 | | 36 | V | reverse polarity protected with 7.5A fuse |
| Analog input levels, V_{IN} | | | 36 | V | short circuit protected |
| Digital input levels, D_{IN} | | | 36 | V | short circuit protected |
| +VREF | | | 36 | V | short circuit protected (-VREF not over-current protected) |
| RS232 | | | 36 | V | short circuit protected |
| Load current, total all outputs | | | 6 | A | |

Environmental ratings

| Parameter | Limit values | | | Unit | Remark |
|---|--------------|------|--------|----------|--------------------|
| | min. | typ. | max. | | |
| EMI | | | | | |
| ISO 14982:1998 | | | | Mhz | 30-1000 Mhz |
| EN 55022:1998 | | | | Mhz | 0.15-30 Mhz |
| ISO 11452-2:1995 | | | 100 | V/m | 20-1000 Mhz |
| ISO 11452-4:1995 | | | 150 | mA | 1-200 Mhz |
| ISO 7637-3 | | | 80 | V | |
| EN61000-4-8 | | | 100 | A/m | |
| ESD | | | | | |
| EN 61000-4-2 (external) | | | 15 | kV | |
| Mechanical environment | | | | | |
| IEC 68-2-64 Fh (random, 10 - 250 Hz) | | | 0.1 | g^2/Hz | 10-20 Hz |
| | | | 0.4 | g^2/Hz | 20-250 Hz |
| IEC 68-2-29 Eb (bump, 6ms) | | | 40 | g | |
| Climate environment | | | | | |
| IEC 68-2-18 Rb2 (water) | | | 3 | min. | 30kPa, 12.5 l/min. |
| IEC 68-2-30 Db (var1: damp, cyclic) | | | 72 | hour | 25-55°C, 95% RH |
| IEC 68-2-3 Ca (damp, heat steady state) | | | 240 | hour | 44°C, 93% RH |
| IEC 68-2-2-Bb (heat) | | | 72 | hour | 70°C |
| IEC 68-2-1 Ab (cold) | | | 16 | hour | -40°C |
| IEC 68-2-14 Nb (change of temperature) | | | 10 x 6 | hour | -40 to 70°C |
| Chemical environment | | | | | |
| IEC 68-2-52 Kb (salt mist, cyclic) | | | 72 | hour | |

Operation

-40 °C < T_A < +70 °C (unless otherwise specified)

| Parameter | Limit values | | | Unit | Remark |
|--|--------------|----------|----------|------|-----------------------------------|
| | min. | typ. | max. | | |
| Ambient temperature (no load), T _A | - 40 | | +70 | °C | |
| Voltage supply, V _{BAT} | 9 | | 34 | V | |
| Startup delay | | 250 | | ms | |
| Output voltage, VREF | 4.9 | 5.0 | 5.1 | V | |
| Maximum load current, VREF V _{BAT} = 14V V _{BAT} = 28V | | | 50 30 | mA | |
| Current supply V _{BAT} = 14V V _{BAT} = 28V | | 40 55 | | mA | outputs = off, no load on VREF |

Input

-40 °C < T_A < +70 °C (unless otherwise specified)

| Parameter | Limit values | | | Unit | Remark |
|------------------------|--------------|------|------|------|------------------|
| | min. | typ. | max. | | |
| VIN (Voltage input) | | | | | |
| Signal range low | | 0 | 0.05 | V | |
| Signal range high | 4.9 | 5.0 | 5.1 | V | |
| Input resistance | | 62 | | kΩ | |
| Signal resolution | | 5 | | mV | |
| Total unadjusted error | | 15 | 35 | mV | (VREF as source) |
| DIN (Digital input) | | | | | |
| Input level low | | | 1.0 | V | |
| Input level high | 4.0 | | | V | |
| Input hysteresis | | 1.7 | | V | |
| Input resistance | | 5.6 | | kΩ | |

Output

-40 °C < T_A < +70 °C (unless otherwise specified)

| Parameter | Limit values | | | Unit | Remark |
|---|--------------|------------|------|------|---|
| | min. | typ. | max. | | |
| COOUT (Current mode) | | | | | |
| Signal range | 50 | | 3000 | mA | |
| Voltage drop (V _{BAT} - V _{COOUT}) Load = 0.5A Load = 3A | | 0.2 0.8 | | V | |
| Short circuit current limit | | 6 | | A | |
| Linearity error | | 10 | | mA | T _A = 25°C 50mA to 1500mA |
| Temperature error | | 10 | | mA | T _A = -40° to 70°C 50mA to 1500mA |
| Power supply rejection V _{BAT} = 9... 18V V _{BAT} = 24... 34V | | 1 1 | | mA | R _L =6 Ω - 25 Ω (R _L : Resistance of connected load) |
| Load regulation V _{BAT} =14V, R _L =4... 9 W V _{BAT} =28V, R _L =22... 34 W | | 1 1 | | mA | |
| Frequency | 25 | | 333 | Hz | |
| Resolution | | 1 | | mA | Dependent on load, power supply and dither frequency |
| PWMOUT (PWM mode) | | | | | |
| Modulation ratio (MR) low | | 5 | | % | |
| Modulation ratio (MR) high | | 95 | | % | |
| Load current, each active channel (A/B) | | | 3000 | mA | |
| Voltage drop (V _{BAT} - V _{COOUT}) Load = 0.5A Load = 3A | | 0.2 0.8 | | V | |
| Short circuit current limit | | 6 | | A | |
| Dither frequency | 25 | | 333 | Hz | |
| Resolution | | 1 | | %MR | |

Appendix B

Error codes

If one of the following errors is detected, a message will be presented via the LED error codes on the control. In some cases, the control will stop operating or at least shut down the outputs, to increase safety. For a list of possible failure modes, see page 8



WARNING

Do not use the machine if an error message or error code is activated.

The following sections will present what measures to take for different error situations.

LED indicator showing different IQAN-TOC2 modes

| Status | Blink (yellow light) |
|---|----------------------|
| Normal operation | |
| Downloading | |
| BSL ^a power on (yellow/red) | |
| BSL waiting for download (yellow) | |

- a. BSL stands for "boot strap loader" mode. This mode is used to download a new vmAC. To enter BSL mode, the HMI pushbutton is held down during power-up.

| Error code | Error | Primary Blink (red) Error category | Secondary Blink (yellow) Error description |
|------------|------------------------------|---------------------------------------|---|
| 1-1 | Output error | | |
| 1-2 | Input error | | |
| 1-3 | VREF error | | |
| IA | Invalid application | | |
| FE | Fatal error (red, steady) | | |

Appendix C

Dimensioning of the IQAN-TOC2 module

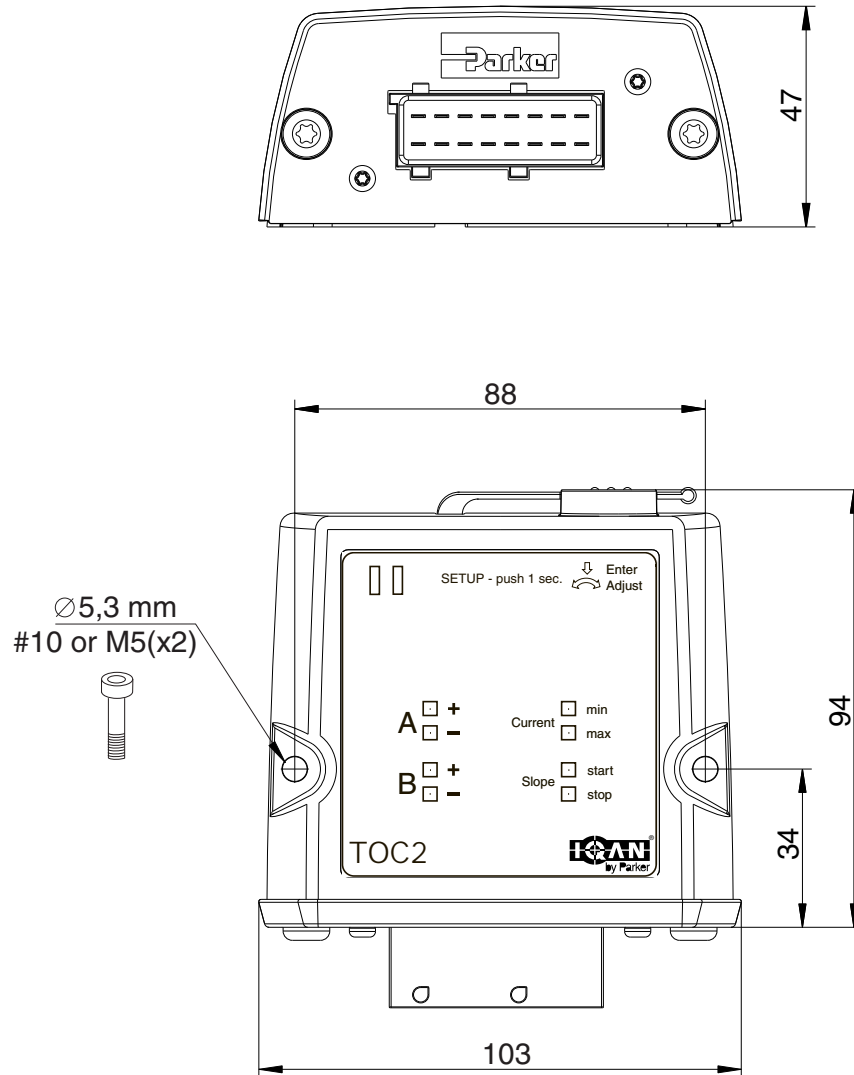

Unit = mm

For latest information visit our website www.iqan.com

Information in this instructionbook is subject to change without notice

Publ no HY33-8300-IB/UK
Edition 08/2009

Parker Hannifin
Electronic Controls Division
SE-435 35 Mölnlycke
Sweden
Tel +46 31 750 44 00
Fax +46 31 750 44 21
www.parker.com

Parker Hannifin
Electronic Controls Division
1651 N. Main Street
Morton IL 61550
Tel +1 309 266 2200
Fax: +1 309 266 6674

