

IQAN-MD3

Instruction book

Publ no MSG17-8395-IB/UK
Edition 2020-02-05

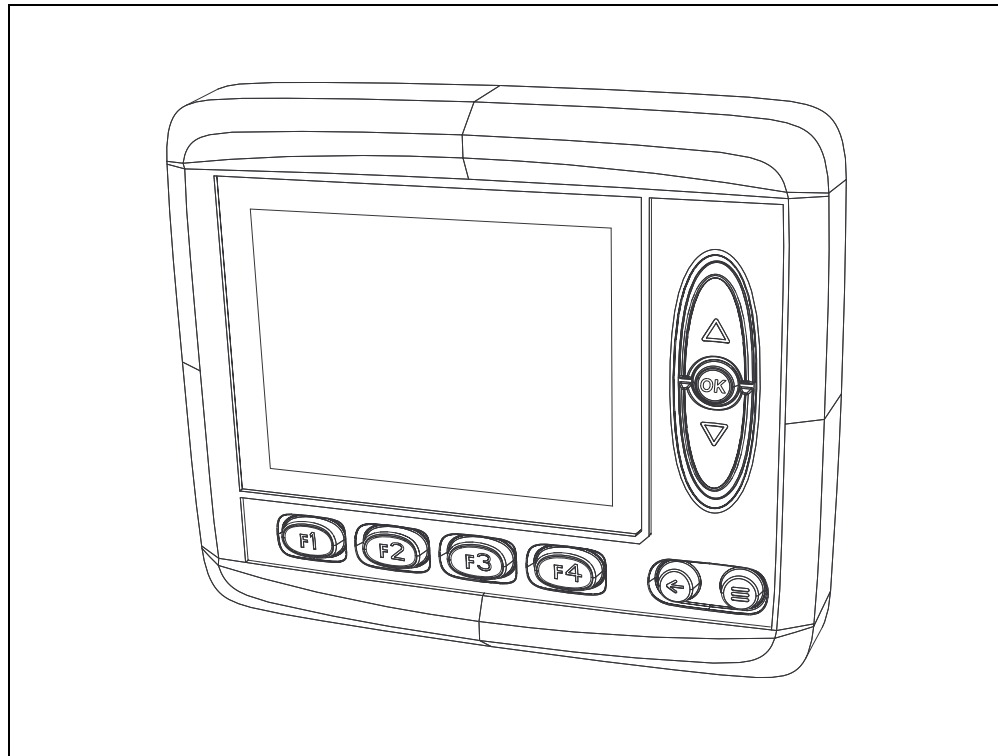

Publication history

The following table provides an overview of the changes made to this document over the course of its publication history.

Revision / date	Description of change
Rev. 001 / 2013-03-11	Converted to new format and added addressing section
Rev. 002 / 2013-04-24	Moved Vref limits to Appendix A, clarified E-stop section
Rev. 002 / 2015-06-30	Added MD3-M15 information
Rev. 004 / 2016-06-17	Changed term 'burn-in' to 'image persistence'
Rev. 005 / 2018-09-13	Added copy of DoC to Markings/Approvals
Rev. 006 / 2019-02-14	Updated Appendix A, added MD3-M18 information
Rev. 006 / 2020-02-05	Offer of sale removed

Copyright 2019 © Parker-Hannifin Corporation. All rights reserved.

No part of this work may be copied, reproduced, replaced, distributed, published, displayed, modified, or transferred in any form or by any means except with the prior permission of Parker-Hannifin Corporation.

Warning

FAILURE OR IMPROPER SELECTION OR IMPROPER USE OF THE PRODUCTS AND/OR SYSTEMS DESCRIBED HEREIN OR RELATED ITEMS CAN CAUSE DEATH, PERSONAL INJURY AND PROPERTY DAMAGE.

- This document and other information from Parker Hannifin Corporation, its subsidiaries and authorized distributors provide product and/or system options for further investigation by users having technical expertise.
- The user, through its own analysis and testing, is solely responsible for making the final selection of the system and components and assuring that all performance, endurance, maintenance, safety and warning requirements of the application are met. The user must analyze all aspects of the application, follow applicable industry standards, and follow the information concerning the product in the current product catalog and in any other materials provided from Parker or its subsidiaries or authorized distributors.
- To the extent that Parker or its subsidiaries or authorized distributors provide component or system options based upon data or specifications provided by the user, the user is responsible for determining that such data and specifications are suitable and sufficient for all applications and reasonably foreseeable uses of the components or systems.

	Publication history	ii
1	Introduction	1
	Warnings	1
	Overview of relevant documentation	2
2	Precautions	3
	Read This	3
	Design of control system	3
	Start-up, maintenance, and diagnostics	4
3	Product description	5
	IQAN-MD3	5
	System overview	5
	I/O overview	6
	CAN related functions	6
	Diagnostics	7
	Communication	7
	HMI (human machine interface)	7
	Features	7
	Display	8
	Environment Specification	8
	IQAN-MD3 menu system	9
	Overview	9
	System information	10
	Preferences	10
	Measuring	11
	Adjusting	11
	Internal Diagnostics	13
	Safe mode	13
	Compatibility	13
	Markings/Approvals	15
4	Safety	16
	Internal diagnostics	16
	CAN-bus interruption	16
	Current check	16
	Emergency stop	16
5	Mounting	17
	Mounting the unit	17
	Dashboard or panel assembly	17
	Mounting considerations	17
6	Installation	19
	Connectors C1 and C2	19
	Connector pin assignments	20
	Supply voltage	21
	Emergency stop	21
	Connecting of Supply Voltage	21
	Polarity reversal	21
	Addressing	22
	IQAN-MD3 use of an ID-Tag	22
	Diagnostic interfaces	23
	CAN diagnostics connection	23
	USB connection	24

	USB and "ground loops" (differences in ground potential)	24
	Reference voltage, VREF	25
	Voltage inputs	26
	Connecting sensors to the voltage inputs	26
	Connecting a 2-wire temperature sensor to voltage in	27
	Connecting switches to the voltage inputs using VREF	27
	Connecting switches to the voltage inputs using +BAT	28
7	Start-up	29
	Start-up procedures	29
	Starting the control system	29
	Prepare for system start	29
	Start the system	29
	Appendix A	30
	IQAN-MD3 Technical Overview	30
	System	30
	Environmental ratings	30
	Markings/approvals	31
	LCD	31
	HMI	31
	Sensor supply - VREF	31
	Signal input - VIN	32
	Signal input - DIN	32
	Power driver - DOUT	32
	CAN	32
	USB	33
	Appendix B	34
	Error messages and actions	34
	Failure Modes	34
	Failure modes for CAN interface	34
	Failure modes for VREF	35
	Failure modes for VIN	35
	Failure modes for DIN	35
	Appendix C	36
	Dimensioning of the IQAN-MD3 module	36

1 Introduction

These instructions are to be used as a reference tool for the vehicle manufacturer's design, production, and service personnel.

The user of these instructions should have basic knowledge in the handling of electronic equipment.

Warnings

Sections marked with a symbol in the left margin, must be read and understood by everyone using the system, carrying out service work, or making changes to hardware and software.

The different symbols used in this manual are defined below.



WARNING

Sections labeled *WARNING* with a caution symbol in the left margin, indicate that a hazardous situation exists. We use warnings, marked with the warning symbol, in two ways.

- As a strong recommendation about work practices when using the product in the machine (e.g. routines when updating an application). This use is common to the term 'hazardous situation', that a person is exposed to a hazard.
- As a way of pointing out important information for the machine designer that in some way relates to safety. This includes the design of the physical machine, and also the application program being developed for the control system.

Not all document sections that contain information about safety are marked with a warning symbol (there would be warnings everywhere). Failure to comply with the recommendations can cause unintentional, and unexpected behavior of the control system. This can potentially cause death, serious injury or property damage.



NOTICE

Sections labeled *NOTICE* with a notice symbol in the left margin, indicate there is important information about the product. Ignoring this could result in less than optimal performance, or damage to the product.

Contact the manufacturer if there is anything you are not sure about or if you have any questions regarding the product and its handling or maintenance.

The term "manufacturer" refers to Parker Hannifin Corporation.

Overview of relevant documentation

The following publications are relevant for users of this product.

The main documentation contains information that is not found elsewhere.

The additional documentation contains product information in a compact format, for details on the information found in those documents, consult this manual.

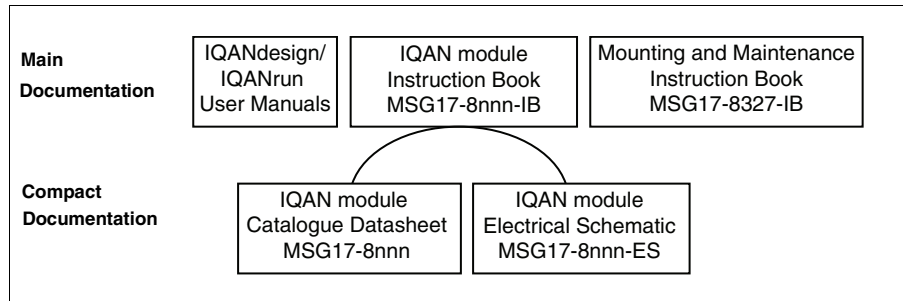

The IQAN module documentation system.

2 Precautions

Work on the hydraulics control electronics may only be carried out by trained personnel who are well-acquainted with the control system, the machine and its safety regulations.



WARNING

Make sure that you have sufficient knowledge before designing, modifying or servicing the control system.

Read the relevant sections of this document before conducting any work on the control system.



WARNING

This product is not field repairable.



NOTICE

As much as possible of the welding work on the chassis should be done before the installation of the system. If welding has to be done afterwards, the electrical connections on the system must be disconnected from other equipment. The negative cable must always be disconnected from the battery before disconnecting the positive cable. The ground wire of the welder shall be positioned as close as possible to the place of the welding. The cables on the welding unit shall never be placed near the electrical wires of the control system.

Read This

Design of control system



WARNING

Risk of injury may be introduced by design of control system!

This product is designed to control hydraulic outputs. The control application must be designed using basic safety principles so that unintentional movement is avoided.

The machine must be equipped with an emergency stop that stops all movement. Please refer to section "Supply voltage".

Before you start

Read this document.

Read the IQANdesign software user manual section on 'application safety'.

Start-up, maintenance, and diagnostics

For all personnel carrying out installation, commissioning, maintenance or troubleshooting.



WARNING

Work on the hydraulics control electronics may only be carried out by trained personnel who are well-acquainted with the control system, the machine and its safety regulations.

Before you start,

Read section "Start-up".

Additional information for service

Mounting and maintenance instruction book.

Additional information for diagnosing the system

Read section "System diagnostics", and see "Appendix B", in this document.

Use the IQANrun software user manual as a reference.

3 Product description

IQAN-MD3

IQAN-MD3 is a combined display and bus master capable of running applications created by IQANdesign. Built on a 32-bit platform the unit has large computational power and is capable of controlling large applications.

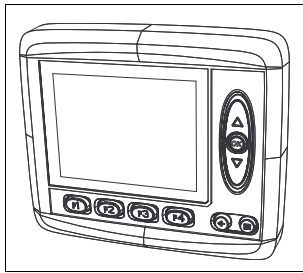

The IQAN-MD3 module.

System overview

The master module, IQAN-MD3, is the central unit in the system, or in the case of a multi-master system, one of the central units. IQAN-MD3 has three CAN buses. The CAN buses support ICP and are able to control IQAN expansion units. SAE J1939 and Generic CAN protocols are also supported on the CAN buses and gives the possibility to interface to 3rd party units. It is recommended to keep one CAN bus available (no traffic or minimal traffic) for diagnostic purposes.

"Soft" function buttons and control buttons in combination with a graphical display makes system feedback with user interaction possible. The display in the module has very high optical performance across a wide operating temperature range and over a wide range of ambient light.

IQAN-MD3 has voltage and digital inputs that are designed to be flexibly configured using IQANdesign software. The unit also has a low power digital output.

All I/O are EMI filtered and protected against short circuit to -BAT and +BAT.

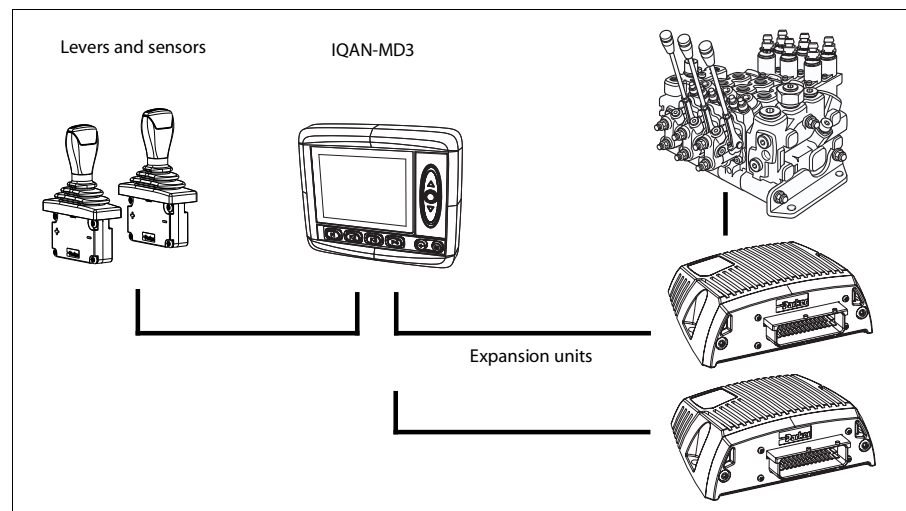

A typical IQAN-MD3 system

I/O overview

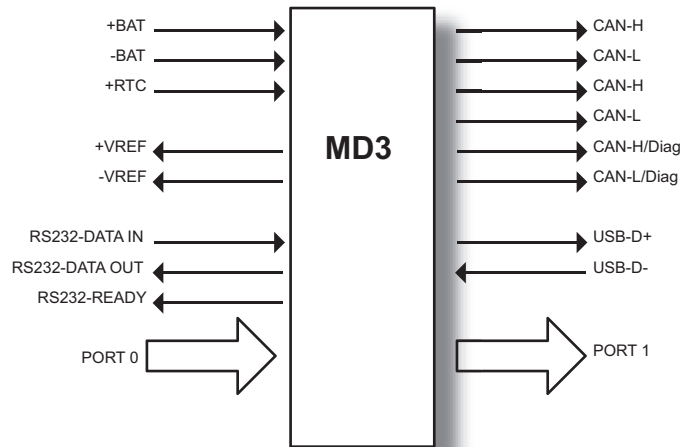

Inputs/Outputs

The IQAN-MD3 module has seven (7) *voltage inputs* VIN-A thru VIN-G for connection of 0-5 Vdc signals. These inputs can be configured as *digital inputs* for reading switches. *Voltage inputs* and *digital inputs* share positions, see below.

(7) Voltage inputs VIN-A, VIN-B, VIN-C, VIN-D.....VIN-G

or

(7) Digital inputs DIN-A, DIN-B, DIN-C, DIN-D..... DIN-G

There is a digital output, DOUT-A, on IQAN-MD3 that may be activated when there is an error message for the system, such as a short-circuit and input or output interruption. By connecting the digital output to a warning lamp or audio signal, the driver is alerted that an error message has been given.

Connect the alarm (audio signal) between pin C2:12 and ground (the battery's negative pole). See the illustration below. An active output gives battery voltage (11-32 Vdc) to the pin. The maximum load is 200 mA.

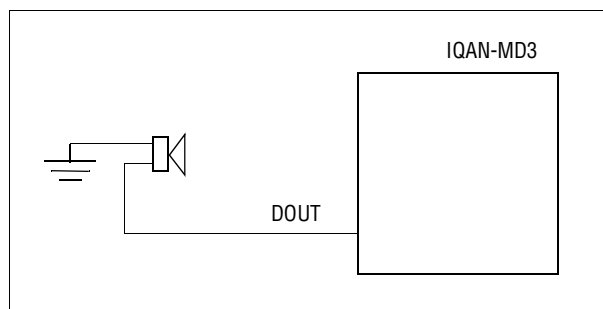

Connection of DOUT as an alarm output.

CAN related functions

The IQAN-MD3 uses three CAN-buses (CAN = Controller Area Network) to communicate with IQAN expansion modules, other systems and diagnostics.

Diagnostics

Any of the IQAN-MD3 CAN buses may be dedicated for diagnostic purposes. This function is available when using IQANdesign 2.0 version or higher.



NOTICE

It is recommended to have one CAN bus dedicated for diagnostic purposes.

Communication

The IQAN-MD3-M15, p/n 20077793 has one USB port for connection with a PC.

The IQAN-MD3-M18, p/n 20085160 does not have a USB port. A USB to CAN adapter must be used. The list of compatible adapters is found on the IQAN forum, or consult your local Parker representative.



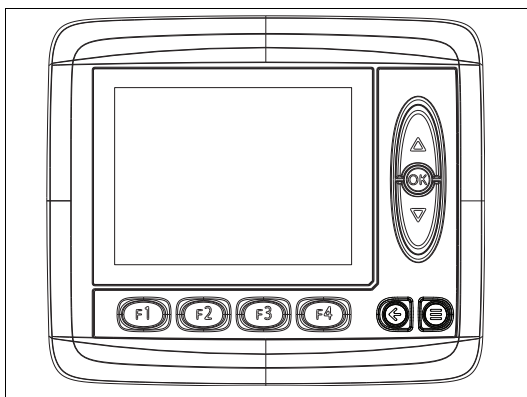

HMI (human machine interface)



IQAN-MD3 front panel HMI.

Features

IQAN-MD3 has a 3.5" color LCD display, 320x240 pixels for reading system information. The front of IQAN-MD3 consists of a control panel with a display and nine buttons.

- F1 thru F4 function buttons.
Programmable 'softkeys' that can be configured by IQANdesign software to bring up a display page, bring up an adjustment group or act as a virtual input.
- Up and down arrow buttons , .
- Navigation buttons that are used to scroll thru selections on a menu page. May be configured by IQANdesign software to bring up a display page, bring up an adjustment group or act as a virtual input.
- OK button .
- Pushing this button equals 'enter'. Saves the value or confirms the selection you have made.
- Menu button .
- Always brings up the Menu page. It is not programmable.
- 'Esc' or BACK button .
- Returns you to the previous display page. May be configured by IQANdesign

software to bring up a display page, bring up an adjustment group or act as a virtual input.

Display

Brightness

The brightness is easily adjusted by pressing the 'menu' button and following the prompts to the backlight settings section.

Image persistence

The IQAN-MD3 TFT LCD, like all other LCD screens, can show image persistence, also known as image sticking, if the same pattern is left on the display for extended periods of time.



NOTICE

To avoid the possibility of image sticking in applications where the display is rarely powered down, a screen saver that alters the display image could be used.

Maintenance

The 3.5" color LCD display is a high quality viewing interface and reasonable care should be taken to maintain it.

The display can be cleaned with an LCD cleaning solution found in many stores. Use a lightly dampened lint-free, non-abrasive cloth when cleaning the display.



NOTICE

To avoid scratches, do not wipe or clean a dry display.

Polarization

The 20072409 MD3 screen has polarizers, the screen is defined by its manufacturer as portrait mode, but we have tilted it to have a landscape mode display. When wearing polarized sunglasses, the effect is for the screen to be unreadable due to the conflicting polarizations. This is easily solved by applying a film to the display. One type of film that is proven to work is NuShield DayVue anti-reflective overlay film. The updated 20077793 MD3-M15 color LCD screen does not have polarizers.

Environment Specification

IQAN-MD3 is a hardened module suitable for outdoor use. However, concentrating cleaning jets on the control surface of the IQAN-MD3 can cause a degradation of the finishing and should be avoided.



NOTICE

To keep the unit's buttons looking their best, do not blast the control surface with cleaning jets.

Back of unit

If the rear surface of the IQAN-MD3 unit is exposed and will be subjected to high pressure steam cleaning, care should be taken around the connector assemblies. The Deutsch DTM connectors are IP67 rated which is suitable for any type of outdoor conditions. However, concentrating the cleaning jets on the connectors of the IQAN-MD3 can cause damage to the connector seals or wire insulation and should be avoided. Use of shielding is recommended to block high pressure cleaning jets, if the rear of the unit is exposed.



NOTICE

To avoid damaging the connector seals or wire insulation, do not blast the connectors with cleaning jets.

IQAN-MD3 menu system

The IQAN-MD3 has an easy to use graphical user interface and menu system. In the display's menu system, you get access to information and settings concerning the IQAN system.

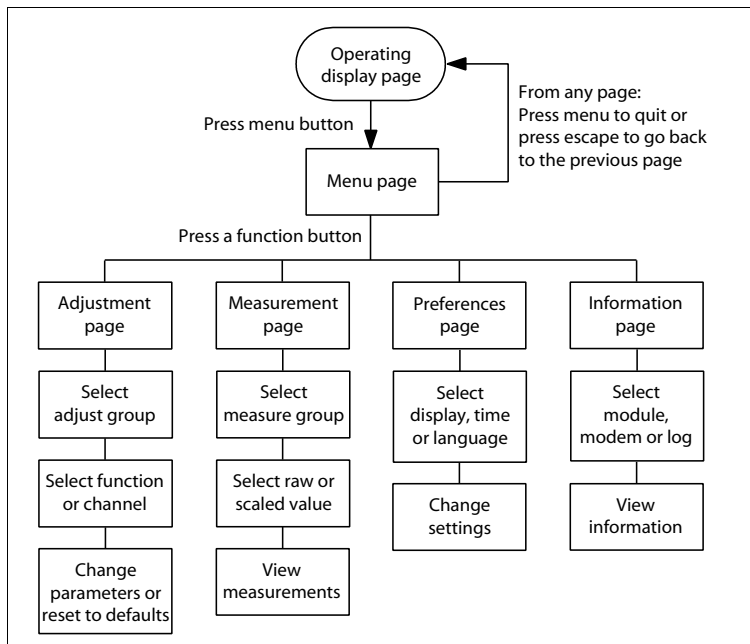

Menu navigation flowchart.

Overview

The menu system is an easy to use set of pages in the IQAN-MD3 that allow you to see module information and logs, set preferences, measure system I/O or adjust parameters.

All of this is done using the control and function buttons on the face of the IQAN-MD3. To begin, go to the main menu page by simply pressing the 'menu' button (three horizontal lines). You may return to the operating display at any time by pressing the menu button again.

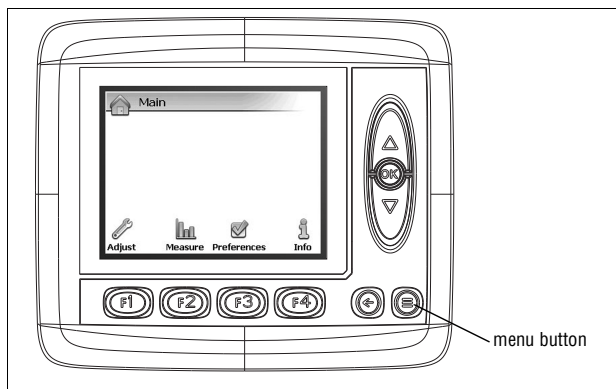

Main menu page.

System information

To see information about your system press the button on the main menu page under the 'Info' icon, F4. This will bring up the information page which displays the loaded application name, the last person who performed an edit and when the edit was done. Other button options now appear for the function buttons that allow you to view information about modules, modem or logs. To return to the previous (main menu) page you can press the 'escape' button. The 'escape' button always takes you back to the previous page. If you have chosen to view information on any of the other pages you are given the option to simply press the button under the 'Main' icon, F1.

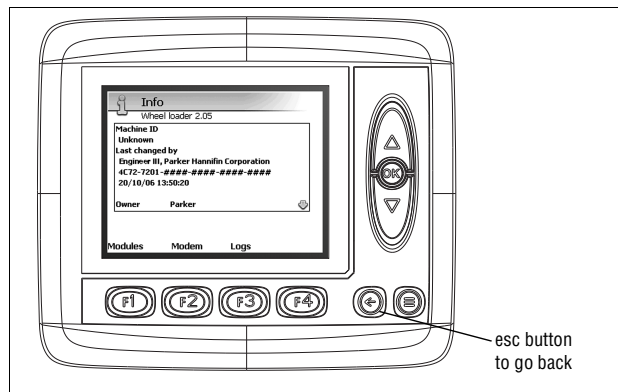

Information page.

Preferences

To set preferences for the IQAN-MD3 press the button on the main menu page under the 'Preferences' icon, F3. This will bring up the preferences page. Other button options now appear for the function buttons that allow you to set preferences for the display, date/time or language. To return to the previous (main menu) page you can press the 'escape' button. If you have chosen to view information on any of the other pages you are given the option to simply press the button under the 'Main' icon, F1.

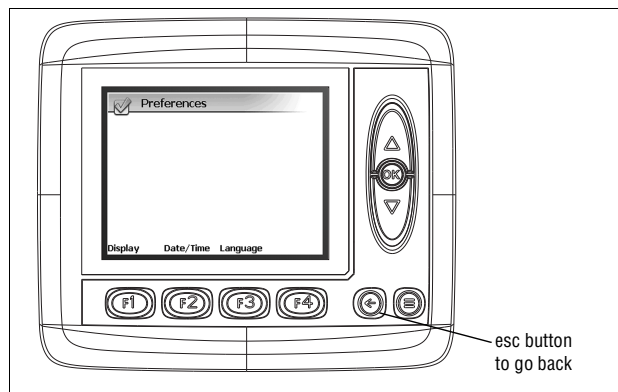

Preferences page.

Measuring

If you would like to measure any channels using the IQAN-MD3 press the button on the main menu page under the 'Measure' icon, F2. This will bring up the measure page that displays the measure groups that have been set up in IQANdesign. To select a measure group you press the up or down buttons until it is highlighted and then press 'OK'. That takes you to a page where you may view the channels in the selected group. Button F2 may now be used to toggle between raw values and scaled values for the channels. To return to the measure page you can press the 'escape' button. To return to the main menu page, you are given the option to simply press the button under the 'Main' icon, F1.

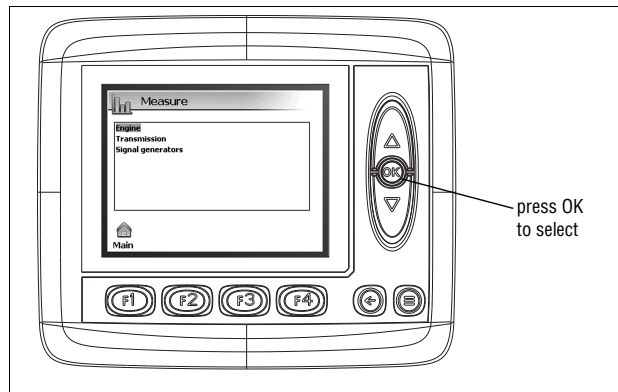

Measure page.

Adjusting

If you would like to adjust any channels using the IQAN-MD3 press the button on the main menu page under the 'Adjust' icon, F1. This will bring up the adjust page that displays the adjustable groups that have been set up in IQANdesign. To select an adjustable group you press the up or down buttons until it is highlighted and then press 'OK'. That will take you to the next page, where you may view the channels in the selected group. If a lock icon,  is next to the group in the list, then a pin code is required to access that group. Press the up, down and OK buttons to enter the pin code

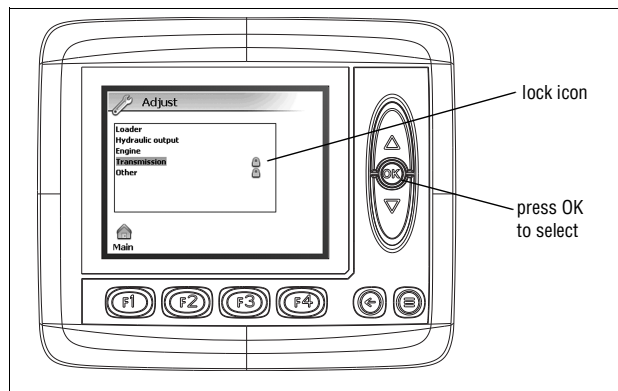

Adjust page.

Once you have selected a group, a list of the adjustable channels is displayed. You may select a particular channel in the same way you selected the group, by using the up and down buttons and pressing OK. To choose the plus or minus direction for adjusting, use the appropriate function button F3 or F4. The current parameters for the highlighted direction are displayed on the right side of the display window. When you have highlighted the desired channel and direction, press OK.

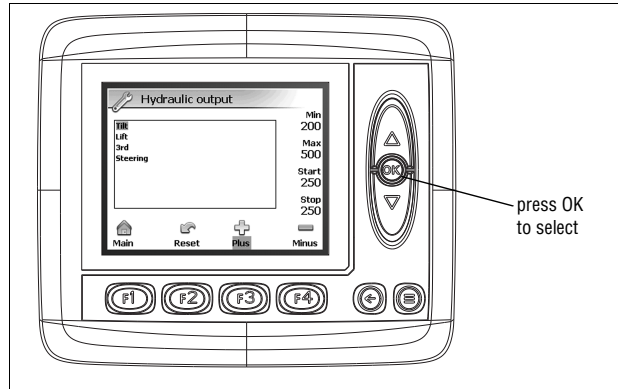

Adjust group page.

Adjusting a parameter

Now you are at the page where the actual adjustment is done. You may toggle through the different parameters by pressing OK repeatedly. When the parameter you wish to adjust is highlighted, you may change it by pressing the up and down buttons. The displayed values change to give you feedback. At any time after adjustments have been made, if you want to return to the default values of the application, you may press the button under the 'Reset' icon, F2. To return to the previous page you can press the 'escape' button. To return to the main menu page, you are given the option to simply press the button under the 'Main' icon, F1.

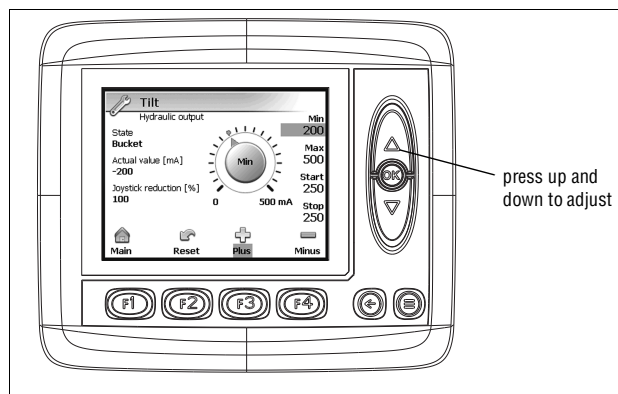

Adjusting a parameter.

Internal Diagnostics

The IQAN-MD3 has a diagnostics page. This page can be useful for obtaining diagnostic information. To view the test page, press the menu and escape buttons simultaneously and hold during power up. To exit test mode, turn the unit off and power up normally.

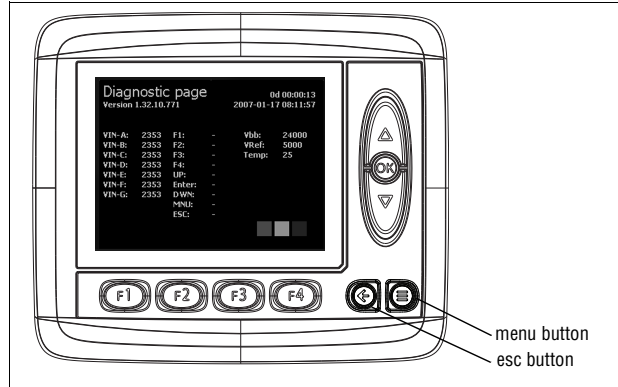

Accessing the diagnostics page.

Safe mode

If necessary, the IQAN-MD3 may be started in safe mode. When started in safe mode, no application is loaded and nothing is running. The screen shows a default background and a dialog box notifies the user that the unit is in safe mode. This can be useful for installing an IQAN-MD3 with an unknown application in memory, when retrofitting of new hydraulic components has occurred or if a user has somehow changed the application in an unacceptable way. To start in safe mode, press the escape button and hold during power up. In safe mode you can then upload a new application to the IQAN-MD3. To exit safe mode, turn the unit off and power up normally.

Compatibility

A redesign of the IQAN-MD3 was done in 2014 due to the 'end of life' of the USB driver IC. This resulted in the part number and description: 20077793 IQAN-MD3-M15.

Original product

20072409, IQAN-MD3

Works with:

All IQANdesign platform software versions

Product with updated USB circuitry

20077793, IQAN-MD3-M15

Works with:

IQANdesign platform software 2.63 or later

IQANdesign platform software 3.15 or later

Another redesign, this time of the IQAN-MD3-M15 was done in 2019, again due to the 'end of life' of the USB driver IC. This resulted in the part number and description: 20085160 IQAN-MD3-M18. The USB was removed from the product.

Product without USB circuitry

20085160, IQAN-MD3-M18

Works with:

IQANdesign platform software 2.63 or later

IQANdesign platform software 3.15 or later

Markings/Approvals

The markings/approvals reflect the state of the products at the time of publishing.



Declaration of Conformity

We: Parker Hannifin Manufacturing Sweden AB
Mobile Hydraulic Systems Division

Located at: Mölnlycke Fabriker 14
S-435 35 Mölnlycke, SWEDEN
Tel. +46 31 750 44 00

Declare that the products identified herein comply with the essential requirements of the following EU directives:

2014/30/EU **EU EMC Directive**
2011/65/EU **EU RoHS II Directive**

Harmonized standards:

ISO 14982:2009 Agricultural and forestry machines - Electromagnetic compatibility -
Test methods and acceptance criteria
EN 13309:2010 Construction machinery - Electromagnetic compatibility of machines
with internal electrical power supply
EN 50581:2012 Technical documentation for the assessment of electrical and
electronic products with respect to the restriction of hazardous
substances

Trade Name: Electrohydraulic Control Systems

Products: **IQAN-MD3**

Signature of responsible party:

A handwritten signature in blue ink, appearing to read 'Håkan Jisland', is written over a light blue horizontal line.

Printed name of responsible party: Håkan Jisland
Position of responsible party: Business Unit Manager

Executed on August 21th 2018, at Mölnlycke, Sweden

4 Safety

Internal diagnostics

The module performs a number of self-checks that improve safety. Checks include monitoring of voltage supplies, checksums on memory and a watchdog that monitors software execution. The module is using a real time operating system which supervises software execution.

If a critical error is detected, the module is stopped, with CAN-bus and outputs off.

CAN-bus interruption

The IQAN modules communicate on a CAN-bus. Both the master module and expansion modules check for any interruptions in CAN-bus communication. If an error occurs the master will use zero or an application defined error value for the module inputs, and the module outputs will be off.

The error will be presented on the master/display module, if there is one, and with a related blink code on the IQAN module status LEDs, see Appendix B.

Current check

For modules with proportional outputs, when used in current mode a current check is performed. If an error is detected, this will be indicated on the master module, and the output will shut off.

The module can detect open-circuit, short-circuit to +BAT/-BAT or short-circuit to other proportional output and return pins.

Emergency stop



WARNING

Risk of injury!

The emergency stop must disconnect the power supply to the module; do not connect the emergency stop as a signal input only.

The emergency stop must be installed so that the risk of reverse feed of the module is avoided, see section "Supply voltage".

5 Mounting

Mounting the unit

The IQAN-MD3 unit should be mounted according to the following instructions.

Dashboard or panel assembly

- When installing in a dash or panel the recommended panel thickness is 1.0 - 3.5 mm. Use PT40 screws to mount the unit

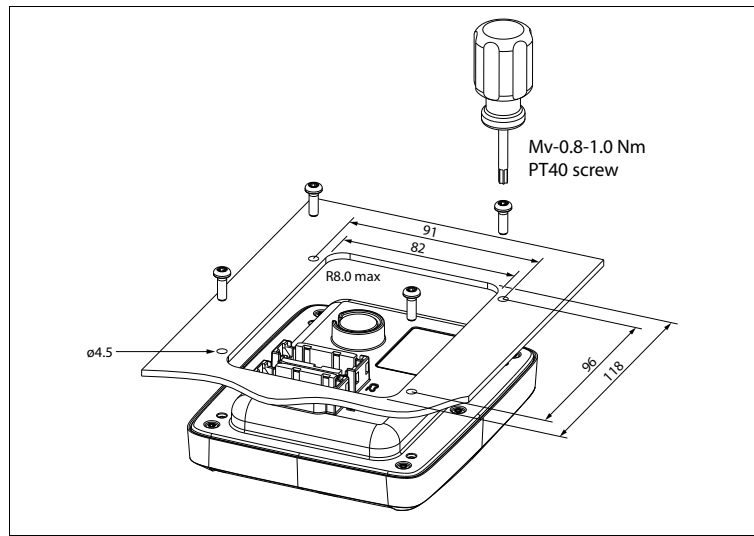

Mounting the IQAN-MD3.



NOTICE

Select the screw length so that the thread engagement in the unit is 8-11 mm.

- Less engagement and the screw may not hold.
- More engagement and the housing may be damaged.

Mounting considerations



NOTICE

IQAN-MD3 shall be positioned in the machine per the following instructions:

- The unit is designed for outdoor use. Position the unit in desired location and make sure that it is not exposed to mechanical damage.
- The connectors on the reverse side of the unit should be accessible.
- Position the unit so there is no risk that the cabling can be folded, crushed, worn or damaged in any way.

- Leave sufficient room behind the unit to insert connectors. Less than 75 mm clearance will stress the cabling and distort the seals in the connectors. This can cause the environmental specification not to be met.

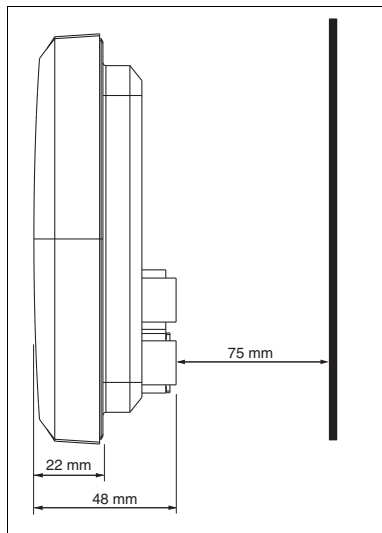

Distance behind the unit.



NOTICE

Take careful consideration when positioning the unit.

- Position the unit so there is no risk to be exposed to external heat, e.g. from the engine or heater.
- The best readability will be achieved by positioning the front face of the unit directly towards the operator.
- Extended periods of exposure to direct sunlight can cause an internal temperature exceeding 75°C which may cause permanent degradation of the LCD display.



NOTICE

Both of the connectors, C1 and C2, must be properly installed in the unit.

- If you leave a connector unplugged, the unit will not be sealed.
- If unused wire positions in a connector are not closed with the recommended plugs, the unit will not be sealed.

6 Installation

Connectors C1 and C2

Connector kit	Parker 20073081
Housing, C1	Deutsch no. DTM06-12-SA
Pin type	Deutsch no. 1062-20-0222
Wedge type	Deutsch no. WM12S
Sealing plug	Deutsch no. 0413-204-2005

C1 (DTM12 key A)

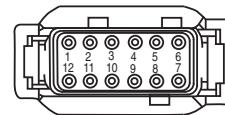

Housing, C2	Deutsch no. DTM06-12-SB
Pin type	Deutsch no. 1062-20-0222
Wedge type	Deutsch no. WM12S
Sealing plug	Deutsch no. 0413-204-2005
Recommended cable	0.75-1 mm ² (18 AWG)

C2 (DTM12 key B)

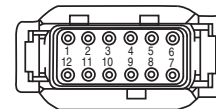

NOTICE

No pin may be "double crimped". That means only one wire may be attached to any given pin. Failure to follow this instruction will cause the module to not meet the environmental specification.

Make "Y" connections or splices using weatherproof methods external to the IQAN-MD3 connectors.



Connector pin assignments

Symbol	Pin No.	Input Output	Function
+BAT	C1:12	-	Power supply
-BAT	C1:1	-	Power supply
+RTC	C1:7	-	Power supply for RTC.
+VREF	C2:8	-	Voltage reference for external sensors. Sourcing +5V.
-VREF	C2:5	-	Voltage reference for external sensors. Return (0V).
ADDR-L	C1:6	-	Address lowpin for IDtag. For multi-master systems.
CAN-A-L	C1:2	-	CAN low voltage bus line.
CAN-A-H	C1:11	-	CAN high voltage bus line.
CAN-B-L	C1:3	-	CAN low voltage bus line.
CAN-B-H	C1:10	-	CAN high voltage bus line.
CAN-C-L	C1:4	-	CAN low voltage bus line for diagnostics.
CAN-C-H	C1:9	-	CAN high voltage bus line for diagnostics.
RS232-TD ^a	C1:8	O	RS232 data out
RS232-RD ^a	C1:5	I	RS232 data in
USB-D- ^b	C2:6	-	USB low voltage bus line. USB gnd connects to -VREF. USB shield may only be connected on PC side.
USB-D+ ^b	C2:7	-	USB high voltage bus line. USB gnd connects to -VREF. USB shield may only be connected on PC side.
P0			P0 is a 7 input port with alternative functions.
			VIN DIN
P0.0	C2:1	I	VIN-A DIN-A
P0.1	C2:2	I	VIN-B DIN-B
P0.2	C2:3	I	VIN-C DIN-C
P0.3	C2:4	I	VIN-D DIN-D
P0.4	C2:9	I	VIN-E DIN-E
P0.5	C2:10	I	VIN-F DIN-F
P0.6	C2:11	I	VIN-G DIN-G
P1			P1 is a 1 output port.
			DOUT
P1.0	C2:12	O	DOUT-A

a. Serial modem is no longer supported.

b. No USB in 20085160, MD3-M18

Supply voltage

Before any installation of the IQAN system can take place, make sure the ignition lock is turned off and the battery is disconnected.

Emergency stop

Make sure an *Emergency Stop* disconnecting the power supply, is easily accessible at any time. The figure below shows how to connect the emergency stop.

Connecting of Supply Voltage

The supply voltage, should be within the operating interval, see Appendix A. Connect the supply voltage to +BAT and -BAT. Protect the module by using a fuse. For recommended fuse level, see Appendix A.

RTC supply

IQAN master modules have a clock that is used for date/time stamping when logging data. The *real time clock*, +RTC, requires a separate positive power connection.

Connect the supply voltage to +RTC through a 1.5K ohm resistor. The resistor should be as close to the battery as possible for safety.

IQAN expansion modules do not have +RTC.



WARNING

Risk of injury!

To reduce the risk for uncontrolled supply of an IQAN master module, i.e., a short circuit between the +RTC cable and +BAT, a resistor must be connected between the battery and the +RTC input. This is important as this line is not controlled by an emergency stop.

The resistor should be placed close to the battery, as the 'protected' part is the cable between the resistor and the unit.

This will prevent the +RTC wire from powering up the unit if shorted to +BAT.

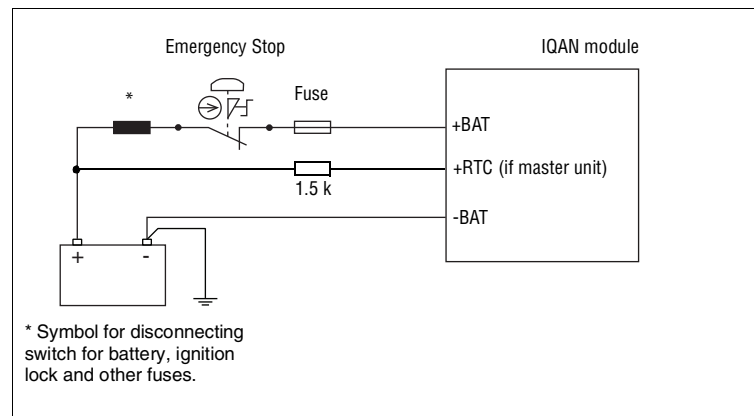

Connecting the emergency stop and voltage supply.



NOTICE

Do not use the chassis as the negative terminal.

Polarity reversal

The module is protected against power supply polarity reversal and over-voltage, provided an external fuse is being used.

If this fuse is not used, polarity reversal can damage the unit.

Addressing

IQAN-MD3 use of an ID-Tag

In IQANdesign 3.0 and higher software, more than one IQAN master module can be used together in a multi-master system. The master modules are each given a unique address by using an ID-Tag. The value of the ID-Tag identifies the master and will enable a single project application to be loaded into more than one master module over the CAN bus. The functionality needed for each master is loaded based on the ID-tag address. By default, if no ID-tag is installed, the MD3 will be address 0.

Identification of an IQAN-MD3 by address

For normal operation of an IQAN-MD3 in a single master system, the ID-Tag is not used. It is only needed when the IQAN-MD3 is used in a multi-master system, and an address other than '0' is needed. The connection of an ID-Tag between +VREF and ADDR-L will assign an address to the IQAN-MD3 master module. The desired functionality based on address is built into the project file using IQANdesign software. For more information, please refer to the IQANdesign user manual.

It is the combination of *address* and *type* that gives each master module a unique identification.

EXAMPLE

If having an IQAN-MD3 master module with an ID-Tag of address 3, the system will recognize an address value of 3 to the application. You could have one MD3-0, one MD3-3 and one MC3-1 (or some other combination of master units) in the same multi-master system.

The maximum number of MD3 addresses is 6, denoted as addresses 0, 3, 4, 5, 6, 7 respectively.



NOTICE

Addresses 1 and 2 are reserved and can not be used for addressing an IQAN-MD3. In order to assign any IQAN-MD3 a unique address, an *ID-Tag* will have to be connected to the positions +VREF and ADDR-L.

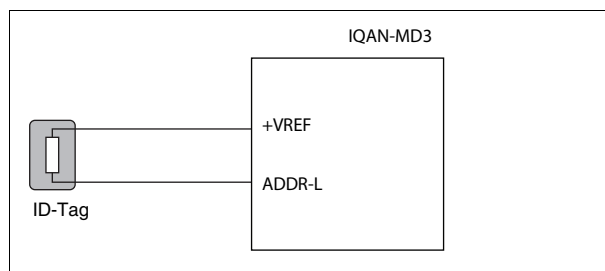

Connecting of Id-Tag.

Diagnostic interfaces

IQAN software includes many tools for tuning, measuring, accessing logs and otherwise checking the performance or troubleshooting your control system. To use the diagnostic tools with an IQAN master module you may choose between different ways to connect to the unit.

CAN diagnostics connection

One of the CAN buses of the IQAN master module may be dedicated for diagnostics. Reserving a bus for diagnostics ensures that signals are not interrupted by other bus traffic. A high-speed CAN interface is needed to use this feature. Contact Parker for information about supported CAN interfaces.

A termination resistor is usually required at the CAN interface on the PC. Parker part number 5030082 or 5030182, or an equivalent 120 ohm resistor may be used. A flying lead cable may be connected to the IQAN master to provide a connector interface. The connection from IQAN master module to diagnostic CAN interface can then be made quite easily. It is recommended that the connector be a sealed, automotive type. When not being used this connector should be protected from the environment with a cover or mating blank plug.

The recommended wiring to the IQAN master module connector is shown below.

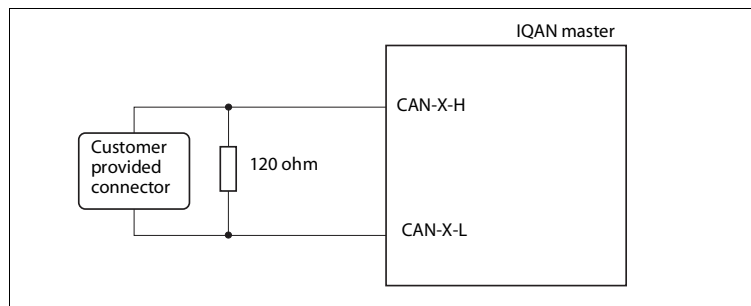

Connecting for CAN communication.

USB connection

The IQAN-MD3, p/n 20072409 and MD3-M15, p/n 20077793 master displays have an *USB interface* for communicating with IQAN software and for diagnostics.



NOTICE

The IQAN-MD3-M18, p/n 20085160 does NOT have an USB interface. Loading of programs or performing diagnostics is done over CAN. See *Best practice* below.

A flying lead cable, 5030124 may be connected to the MD3 or MD3-M15 to provide an USB type B connector interface. The connection from the module to PC can be made with a standard USB Type A male to Type B male cable.

Connection of Parker cable 5030124 is shown below.

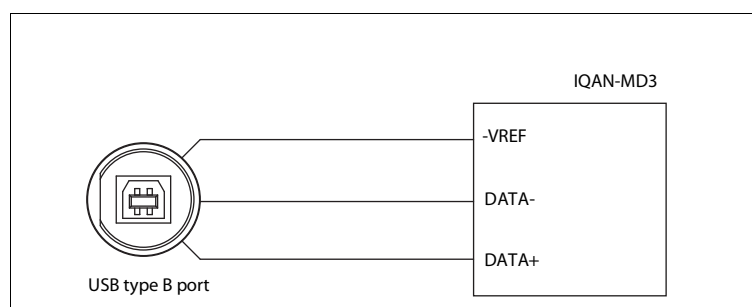

Connecting for USB communication.



NOTICE

It is recommended that the two data wires, *DATA+* and *DATA-*, be a twisted pair, 15 twists/meter. Use *-VREF* for the ground connection as shown.

USB and "ground loops" (differences in ground potential)

When systems consisting of machines, modules, computers and other devices with different ground potentials are connected by a USB cable, a ground loop may be created. The grounds may only differ by a few millivolts, or by much more. This can be significant when compared to the low level voltage signals that are used in USB data transmission.



NOTICE

Protect the PC and unit from damage due to ground loops and surges!

Ground loops can cause problems in communicating and in extreme cases the amount of current flow can damage the USB transceiver in the PC or the module.

A recommended way to prevent ground loops is to ensure that your system includes isolation. Isolation protects your PC from damage and preserves the integrity of your data by physically separating the electrical connections between the PC and the unit.

Good: Using a battery-powered laptop can prevent the formation of accidental ground loops and short circuits. This protection only holds true, however, as long as the laptop is not also connected to self-powered devices such as printers.

Better: Isolation can be provided by adding an isolated USB hub between the PC and the unit.

Best: Use a CAN-USB interface with galvanic isolation and communicate with unit via CAN bus. This setup is used in the automotive industry for diagnostics.

Reference voltage, V_{REF}

The IQAN module is internally equipped with a voltage regulator to generate the reference voltage V_{REF} . The standard reference voltage will feed different kinds of sensors and potentiometers.

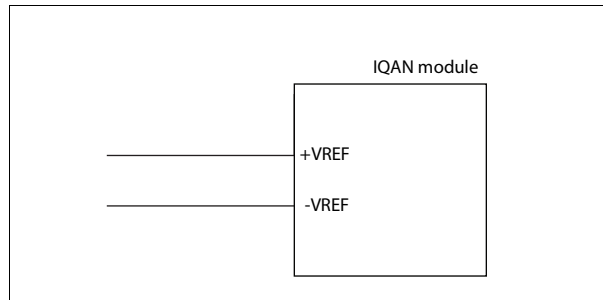

V_{REF} positions.



NOTICE

It is strongly recommended to use the module's $-V_{REF}$ and $+V_{REF}$ to all sensors and potentiometers that are connected to the module inputs. This will reduce bad measurement based on potential fault (i.e. different ground points for other supplies in relation to the IQAN module ground, -BAT).

Maximum load for the V_{REF} , see "Appendix A".

Voltage inputs

Connecting sensors to the voltage inputs

The sensor signal range must be 0-5 Vdc. To detect signal errors such as short circuits or interruptions the active signal range be within 0.5-4.5 Vdc.

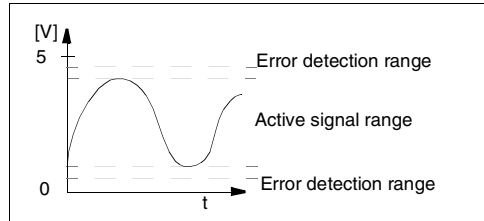

Active signal range.

The current consumption related to the voltage input is negligible.

The positive terminal of the sensor is connected to the +VREF position and the corresponding negative terminal to the -VREF position. The sensor signal is connected to appropriate VIN position.

EXAMPLE

Connect the positive and negative terminals of the position sensor to +VREF, and -VREF, respectively. Then connect the sensor signal to VIN-X.

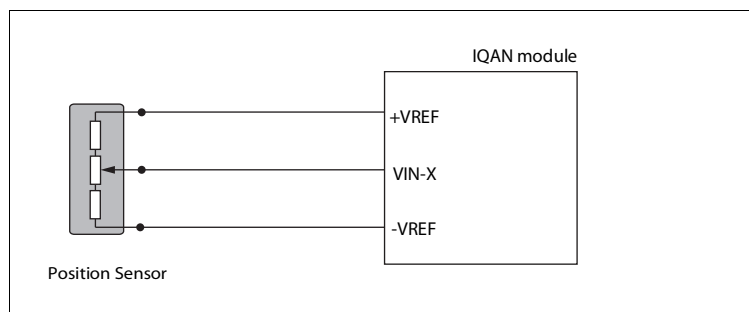

Connecting VREF and sensor signal VIN-X.



NOTICE

The negative terminal of the sensor must not be connected to the chassis.
Maximum load for VREF position: see Appendix A.

Connecting other 3 wire sensors

The same type of connection shown for potentiometers is used for other 3 wire sensors supplied with power from the regulated 5VDC supply, VREF. This includes active temperature sensor IQAN-ST, pressure sensor IQAN-SP and Hall-effect levers IQAN-LST or IQAN-LSL.

Connecting a 2-wire temperature sensor to voltage in

When you connect a PTC (positive temperature coefficient) temperature sensor you may need to use a pull up resistor on the input signal. Please check the technical data for your specific temperature sensor.

EXAMPLE

Connect the negative terminal of the temperature sensor to -VREF, and the signal to VIN-X. The pull up resistor will be connected between VIN-X, and +VREF.

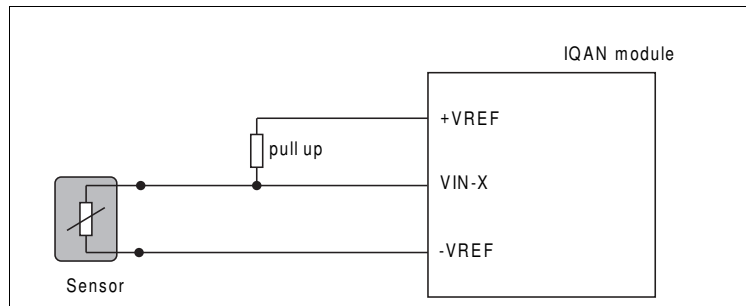

Connecting -VREF and temperature sensor signal VIN-X.

The pull up resistor value for a $R_{25}=2000\Omega$, PTC sensor is 4,7 K Ω .

Connecting switches to the voltage inputs using VREF

Switches could be connected to the voltage inputs, to create a digital on/off signal. The switches should be connected to +VREF and VIN/DIN respectively for 5V signal. The current consumption for the input is negligible.

EXAMPLE

Connect the positive and negative terminals of the switch to +VREF, and VIN-X, respectively.

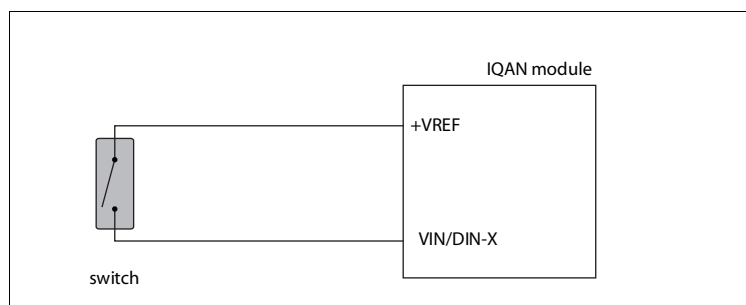

Connecting a switch to VIN-X and VREF.



NOTICE

Maximum load for VREF position, see "Appendix A".

Connecting switches to the voltage inputs using +BAT

It is recommended to connect system voltage +BAT to the input through a switch in order to reserve 5Vdc VREF for sensors and potentiometers.

EXAMPLE

Connect the positive and negative terminals of the switch to supply or the unit's +BAT, and DIN-X, respectively.

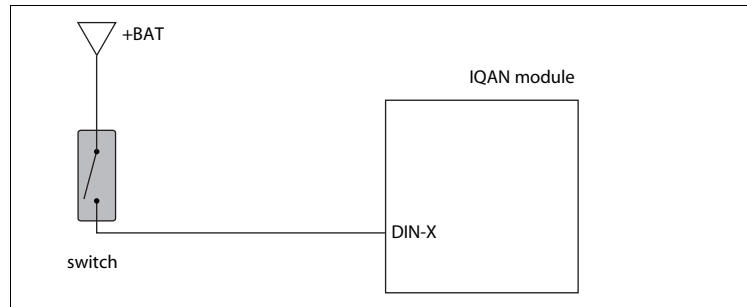

Connecting a switch to DIN-X and +BAT.

7 Start-up

Start-up procedures

This chapter contains instructions for action to be taken in connection with the initial start.



WARNING

Risk of injury!

If the control system is not fitted properly, the machine could move uncontrollably. The machine's engine shall not be started before the control system is completely fitted and its signals are verified.

Starting the control system

Start the control system as follows:

- Prior to start, all modules and cables are to be fitted correctly.
- Check fuses, i.e. make sure that the supply voltage to the modules is equipped with the correct fuse.
- Make sure that connections for supply voltage and return lines are correct in the cable's conductor joint.
- Make sure an emergency stop is installed.
The emergency stop should disconnect the supply voltage to all modules. Alternatively, the emergency stop may also shut off the diesel engine or a dump valve, and with that, depressurize the hydraulic system.

Prepare for system start



WARNING

Make sure no one is in dangerous proximity to the vehicle to avoid injuries when it starts.

Prepare for the initial system start as follows:

- The engine for the hydraulic system's pump shall be in off position.
- Make sure that all connectors are properly connected.
- Turn on the control system.
- Make sure that voltage is being supplied to all modules; the power/status diode shall be illuminated on all modules. Also, make sure that the master is in contact with all modules by reading the master's display.
- Make sure the emergency stop is functioning properly.

Start the system

Start the system as follows:

- Start the engine for the hydraulic system's pump, assuming that the above mentioned inspections have been carried out and shown correct values.

Calibrate and adjust input and output signals according to the instructions related to the master menu system and check each and every output function carefully.

Appendix A

IQAN-MD3 Technical Overview

System

Parameter	Remark
Temperature Operating temperature Absolute maximum temperature Storage temperature	-30 to 60 °C ¹ -30 to 75 °C -30 to 75 °C <i>Note 1: When the unit detects an internal temperature that exceeds -25°C to +75°C the LCD will be turned off to reduce the risk for permanent damage of the LCD. When turned off the backlight will be used as an indicator with a heart-beat: When the temperature normalizes (within -20°C to +70°C) the LCD will be turned on automatically.</i>
Voltage supply Power-on threshold Over voltage on any pin Reverse polarity protection on +BAT	11 to 32 V typ 6.2 V 34 V (with respect to -BAT), Max voltage on USB signals D+ and D- is 3.5V yes
-VREF load	2 A
Current supply VBAT = 14V VBAT = 28V	outputs = off, no load on VREF typ. 190 mA typ. 130 mA
Current supply RTC VBAT = 14V VBAT = 28V	Same supply current for VBAT=0V or VBAT > 11V max. 4 mA max. 8 mA
Start-up time	typ. 350 ms
Weight	270 g

Environmental ratings

Parameter	Remark
Climate environment Enclosure, water & dust protection Salt mist Damp heat cyclic Damp heat steady state Heat, operation Cold Change of temperature	IEC 60529:2001, IP66; DIN 40050 Part 9:1993, IP6K9K IEC 60068-2-52:1996 Kb, 72 h IEC 60068-2-30:2005 Db, +55°C, 95% RH, 6 cycles IEC 60068-2-78:2001 Cab, +40°C, 93% RH, 21 days IEC 60068-2-2:2007 Bb, +70°C, 72 hours IEC 60068-2-1:1993-02 Ab, -40°C, 16 hours IEC 60068-2-14:1984 Nb, - 40°C to +70°C, 10 x 6 hours
Mechanical environment Random vibration Bump	IEC 60068-2-64: 2008 Fh, 15 - 250 Hz, 0.4 g ² /Hz, 10 h IEC 60068-2-27:1987 Eb, 40 g, 6 ms
EMC Radiated emission Conducted emission Conducted susceptibility Radiated susceptibility Conducted transients susceptibility	ISO 13766:2010/ISO 14982:2009 EN 55025:2003, 0.15-108 MHz, Class 1 ISO 11452-4:2005, 1 - 200 MHz, 1 kHz, 80% AM, 150 mA ISO 11452-2:2004, 200-2000 MHz, 1kHz, 80% AM, 100 V/m ISO 7637-2:2004, Pulse 1, 2a, 2b, 3a, 3b, 4, Level 3; Pulse 5, Level 1 ISO 7637-3:2007, Level 3
ESD, Operation ESD, Handling	ISO 10605:2008, 8 kV (contact), 25 kV (air) ISO 10605:2008, 8 kV (contact)

Markings/approvals

Parameter	Remark
CE	2014/30/EU, EMC directive 2011/65/EU, ROHS 2 directive
E-mark MD3-M15 MD3-M18	ECE Regulation No. 10.04 incl. Amend. 2:2013 Approval number E5 10 R - 04146 No E-mark

LCD

Parameter	Remark
Resolution	320 x 240 dots
Number of Colors	262 K
Active area	71 x 53 mm
Brightness	500 cd/m ²
Viewing angle	60/50/60/60 degree
Contrast Ratio	300
Maximum allowed dot-defect (1 dot / 2 adj. dot)	Bright dot 4/1, Dark dot 5/2
Backlight operating life 100% backlight 50% backlight	min. 15000 hours min. 30000 hours

HMI

Parameter	Remark
Keypad operating life	1x10 ⁵

Sensor supply - VREF

Parameter	Remark
Number of VREF	1
Output voltage	5 V ±150 mV, -30 to 60 °C
Nominal error	10 mV, -30 to 60 °C
Maximum load current	200 mA (VBAT=14 V), 100 mA (VBAT=28 V)
Protection	over load, SCB, SCG
Diagnostics	over/under voltage
Under/over voltage threshold	±250 mV from nominal value

Signal input - VIN

Parameter	Remark
Number of VIN	7 (configuration may reduce number)
VIN full scale	5000 mV \pm 100 mV
VIN resolution	1.2 mV (12 bits)
Input impedance	36 kohm pull-down in parallel with 10 nF
Accuracy with external sensor supply with VREF sensor supply	\pm (0.8 % + 5 mV), -30 to 60 °C \pm (0.2 % + 5 mV), -30 to 60 °C
Protection	SCB, SCG
Diagnostics	defined in application

Signal input - DIN

Parameter	Remark
Number of DIN	7 (configuration may reduce number)
Logic levels low high	<1 V >4 V
Hysteresis	typ. 1,0 V
Input impedance	36 kohm pull-down in parallel with 10 nF
Diagnostics	defined in application

Power driver - DOUT

Parameter	Remark
Number of DOUT	1
Maximum load	200 mA
Power driver voltage drop	typ. 0.3V @ 200 mA load
Leakage current in OFF state	<10 μ A
Protection	over load, SCB, SCG
Diagnostics	no

CAN

Parameter	Remark
Number of CAN buses	3
CAN specification	2.0A and 2.0B
CAN bus speed	125 kbit to 500 kbit
Protection	SCB, SCG

USB

Parameter	Remark
Number of USB buses MD3-M15 MD3-M18	1 0
USB device	USB 2.0 full speed

Appendix B

Error messages and actions

If a fault is detected, a message will be presented on the display.



WARNING

An error message could indicate that a hazardous situation exists. If precautions are not taken, this could result in death, serious injury or major property damage.

Failure Modes

The following tables contain information about the different possible failures that could occur for each module subsystem. In most cases when an error is detected, a message will be presented on the master display. In some cases, the master will turn off or at least shut down the outputs, to increase safety.

Failure modes for CAN interface

Failure mode		Effect
1	CAN-H to -BAT	No CAN communication. All output turned off.
2	CAN-L to -BAT	No CAN communication. All output turned off.
3	CAN-H to +BAT	No CAN communication. All output turned off.
4	CAN-L to +BAT	No CAN communication. All output turned off.
5	CAN-L open circuit	No CAN communication. All output turned off.
6	CAN-H open circuit	No CAN communication. All output turned off.
7	CAN-L to CAN-H	No CAN communication. All output turned off.
8	CAN-termination failure, termination on	No effect
9	CAN-termination failure, termination off	Dependent on CAN size and number of CAN nodes.

Failure modes for VREF

Failure mode		Effect
1	+VREF Open	VIN out of range, will create a VIN error => VIN=Predefined error value.
2	-VREF Open	VIN out of range, will create a VIN error => VIN=Predefined error value.
3	+VREF Short-circuit to -VREF	VREF error => VIN out of range, will create a VIN error => VIN=Predefined error value.
4	+VREF Short-circuited to +BAT	VREF error => VIN out of range, will create a VIN error => VIN=Predefined error value.
5	+VREF Short-circuited to -BAT	VREF error => VIN out of range, will create a VIN error => VIN=Predefined error value.
6	-VREF Short-circuited to +BAT	External fuse (if <7.5A) on +BAT blows.
7	-VREF Short-circuited to -BAT	Not detected.

Failure modes for VIN

Failure mode		Effect
1	VIN Open	VIN out of range, will create a VIN error => VIN=Predefined error value ¹
2	VIN Short-circuited to +BAT	VIN out of range, will create a VIN error => VIN=Predefined error value ¹
3	VIN Short-circuited to -BAT	VIN out of range, will create a VIN error => VIN=Predefined error value ¹

1. Measure is controlled by CAN master and application as a result from the CAN error message. Turning outputs off is controlled by CAN master unit and therefore delayed maximum 2 bus cycles.

Failure modes for DIN

Failure mode		Effect
1	DIN Open	No effect on module, not detected
2	DIN Short-circuited to +BAT	No effect on module, not detected
3	DIN Short-circuited to -BAT	No effect on module, not detected

Appendix C

Dimensioning of the IQAN-MD3 module

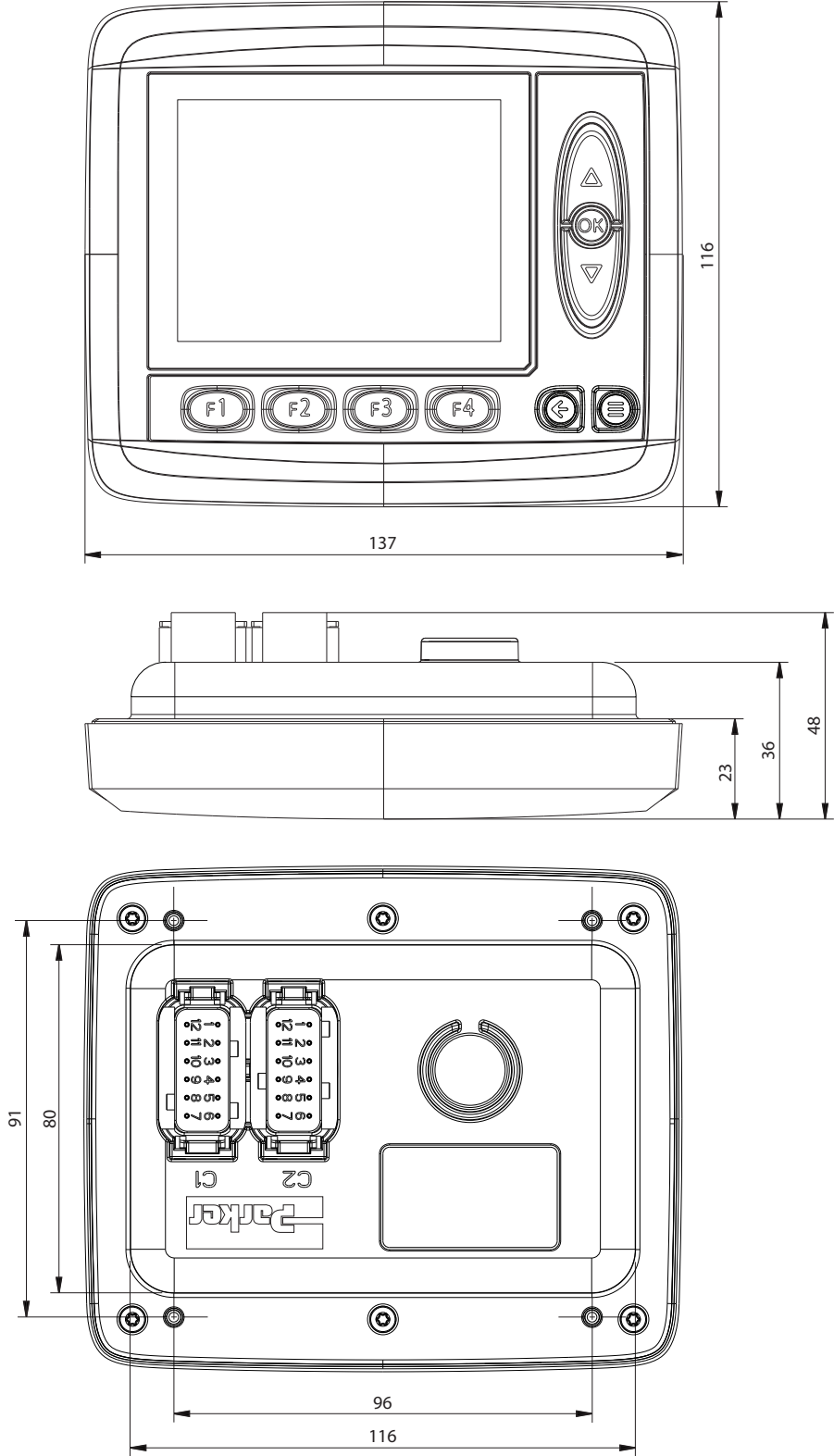

unit = mm

For latest information visit our website www.iqan.com

Information in this instructionbook is subject to change without notice

Publ no MSG17-8395-IB/UK
Edition 2020-02-05

Parker Hannifin
Mobile Systems Division
SE-435 35 Mölnlycke
Sweden
Tel +46 31 750 44 00
Fax +46 31 750 44 21
www.parker.com/ecd

Parker Hannifin
Electronic Controls Division
1651 N. Main Street
Morton, IL 61550
USA
Tel +1 309 263 7788
Fax +1 309 266 6674

