



The full Product Manual is available on line at www.parker.com/ssd

890 QuickStart Manual

AC890PX Drive
PX with STO SIL3/PLe
HA471665U000 Issue 6

aerospace
climate control
electromechanical
filtration
fluid & gas handling
hydraulics
pneumatics
process control
sealing & shielding



ENGINEERING YOUR SUCCESS.

890

Quickstart Manual

AC890PX AC Drive with STO SIL3/PLe

HA471665U000 Issue 6

1) What is Safe Torque Off (STO)?

It is an electronic means of preventing the 890 drive from delivering torque and power to its connected motor. The 890 drive contains this feature as standard. It is a two channel, hardware implemented system. It has the highest possible safety rating for a variable speed drive. It is certified by BGIA, the German Trades Association for Industrial Safety, to Performance Level e (PLe) for a category 3 implementation to EN ISO 13849-1 with an equivalent Safety Integrity Level 3 (SIL 3).

All STO connections are made at terminal block X11.

2) Where Could STO be Used?

In safety control schemes for safety ratings up to category 3 PLe or SIL3. To replace expensive but less reliable drive output contactors, including for emergency stop purposes. The 890 STO function can also be used to implement Safe Stop 1 (SS1).

3) To Use the STO Function - What Should I Do Next?

Read and observe all the requirements in the STO chapter 4 of the Engineering Reference Manual, available on line at www.parker.com/ssd, use the appropriate standards and risk assessments.

4) Replacing a NON STO Drive OR the STO Function is Not Required - What Should I Do Next?

Simply disable the STO function by Linking –

X11/01 and X11/03 to X14/03 (24V) and separately link X11/02 OR X11/04 to X14/04 (0V).

The rest of this quick start manual then applies.

5) On Start Up the MMI Displays “ ***Tripped*** SAFE TORQUE OFF ” or on a 6511 MMI “ASTO” . Why ?

Because no connections to X11/01 OR X11/03, they are at 0V, the STO feature has been enabled i.e. failed safe. Simply disable the STO feature by fitting the links described in item 4) above.

© Copyright 2016 Parker Hannifin Manufacturing Ltd.

All rights strictly reserved. No part of this document may be stored in a retrieval system, or transmitted in any form or by any means to persons not employed by a Parker Hannifin Manufacturing Ltd., company without written permission from Parker Hannifin Manufacturing Ltd. Although every effort has been taken to ensure the accuracy of this document it may be necessary, without notice, to make amendments or correct omissions. Parker Hannifin Manufacturing Ltd., cannot accept responsibility for damage, injury, or expenses resulting therefrom.

Contents

	<i>Page</i>
Safety	5
Hazards to Personnel	5
Application Risk	5
• Risk Assessment	6
• Accessibility	6
• Protective Insulation	6
• RCDs	6
Introduction	7
About this QuickStart	7
Overview	8
• AC890PX (top wire entry)	8
• AC890PX (bottom wire entry)	8
• AC890PX (bottom wire entry)	9
Installation	9
Installation	10
Mounting Dimensions	10
Air Flow	10
Environmental Conditions	10
AC890PX Power Connections	11
• Components : Top Wire Entry	11
• Wiring Diagram : Top Wire Entry	12
• Components : Bottom Wire Entry	13
• Wiring Diagram : Bottom Wire Entry	14
Auxiliary Transformer Taps (C)	15
AC890PX Control Connections	16
AC890PX Feedback Connections	16
AC890PX Feedback Connections	17
Drive Start-up	18
Before Applying Power :	18
Drive Set-up	18
Motor Data	18
Quick Setup Parameters	19
Autotune	20
Running in Local	21
Running in Remote	21
Appendix A: Using the 6901 Keypad	22
The Menu Structure	23
Appendix B: Analog and Digital I/O	24
Appendix C: Compliance	27
EMC Emissions	27
EMC Connections	27

Contents

Planning Cable Runs	<i>Page</i> 27
Appendix D: Electrical Ratings	29

Safety

IMPORTANT: Please read this information BEFORE installing the equipment.



This manual is for anyone installing and operating this unit.



You must be technically competent to install and operate this unit.

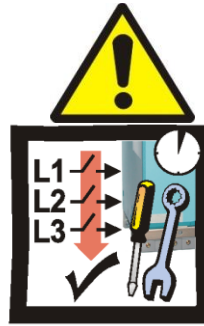

Before working on the unit, isolate the mains supply from terminals L1, L2 and L3 and wait 3 minutes.

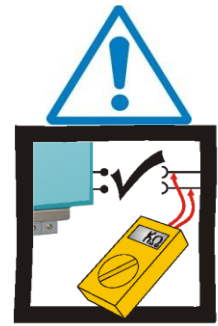

Disconnect the unit from circuits when doing high voltage resistance checks.

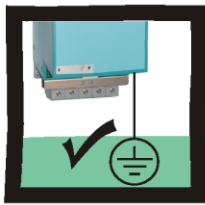

The unit must be **permanently earthed** due to the high earth leakage current.

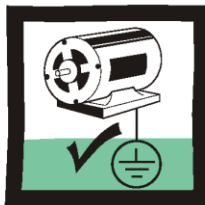

The drive motor must be connected to an appropriate safety earth.



Electrostatic discharge sensitive parts : observe static control precautions.



Copy existing 890 parameters to any replacement 890 unit

Hazards to Personnel

WARNING!

This equipment can endanger life through rotating machinery and high voltages. Failure to observe the following will constitute an **ELECTRICAL SHOCK HAZARD**.

Metal parts may reach a temperature of 70 degrees Centigrade in operation.

Before working on the equipment, ensure isolation of the mains supply from terminals L1, L2 and L3. Allow at least 10 minutes for the drive's capacitors to discharge to safe voltage levels (<50V). Use the specified meter capable of measuring up to 1000V dc & ac rms to confirm that less than 50V is present between all power terminals and between power terminals and earth.

Application Risk

The specifications, processes and circuitry described herein are for guidance only and may need to be adapted to the user's specific application.

Parker Hannifin Manufacturing Limited does not guarantee the suitability of the equipment described in the Manual for individual applications.

Risk Assessment

Under fault conditions, power loss or other operating conditions not intended, the equipment may not operate as specified. In particular:

- The motor speed may not be controlled
- The direction of rotation of the motor may not be controlled
- The motor may be energized

If the STO feature of the 890 drive is to be used, the user must undertake a risk assessment for the application. The user must then verify that their design, which includes the 890 drive, satisfies the Performance Level (PL) or Safety Integrity Level (SIL) required by the risk assessment.

Under no circumstances must the STO feature be used without first reading and fully understanding chapter 4 (Safe Torque Off) of the Engineering Reference Manual. All safety warnings therein must be observed.

Accessibility

All live power terminals are IP20 rated only, accessible with the enclosure door open.

Protective Insulation

- All control and signal terminals are SELV, i.e. protected by double insulation. Ensure all wiring is rated for the highest system voltage.

NOTE *Thermal sensors contained within the motor must be single/basic insulated.*

- All exposed metalwork in the Drive is protected by basic insulation and bonding to a safety earth.

RCDs

Not recommended for use with this product. Where their use is mandatory, use only Type B RCDs (EN61009).

Caution

This is a product of the restricted sales distribution class according to IEC 61800-3. It is designated as “professional equipment” as defined in EN61000-3-2. Permission of the supply authority shall be obtained before connection to the low voltage supply.

Introduction

The AC890PX is designed to control 3-phase induction or permanent magnet AC motors, or to be used as an active front-end.

- Remote control using configurable analogue and digital inputs and outputs.
- Local control using the Keypad.
- Use the Drive System Explorer Configuration Tool (DSE 890) to give access to parameters, diagnostic messages, trip settings and application programming.
- Fit Options to the unit to give serial communications and closed loop speed control.

IMPORTANT: *Motors used must be suitable for Inverter duty.*

About this QuickStart

This QuickStart will:

- Familiarise you with the terminals and operation of the unit.
- Provide **basic*** installation details and a quick set-up procedure.
- Show you how to Autotune the drive and start the motor.

** Because the 890 is a system product and we have no knowledge of your application, we detail the quickest way to power-up the drive using a simple earthing scheme with minimal control wiring. Refer to the full Engineering Reference Manual for items not covered in this QuickStart.*

Provided with every 890 unit is a :

- Quickstart
- Keypad
- Customer-ordered Options

This QuickStart assumes that:

- You are a qualified technician with experience of installing this type of equipment.
- You are familiar with the relevant standards and Local Electric Codes (which take precedence).
- You have read and understood the Safety information provided at the front of this QuickStart.
- You realise that this guide contains only basic information and that you may need to refer to the Engineering Reference Manual to complete your installation.
- You are not using the Safe Torque Off (STO) feature of this product and that you will disable it as instructed in this QuickStart manual.
Safety Note – Use of the STO feature requires full compliance with the STO chapter 4 of the Engineering Reference Manual to which the user must first refer.

Overview

AC890PX (top wire entry)

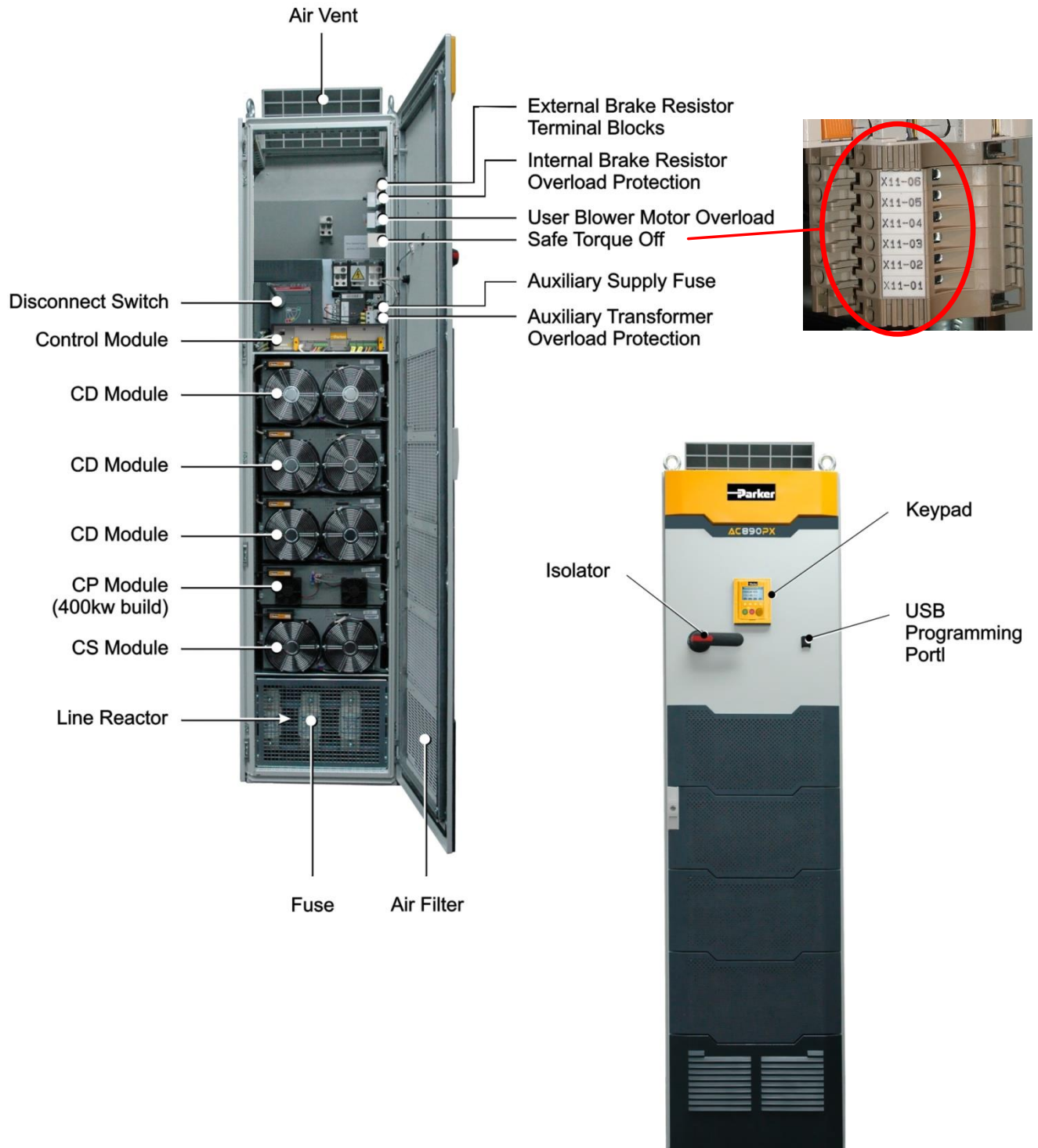

AC890PX (bottom wire entry)

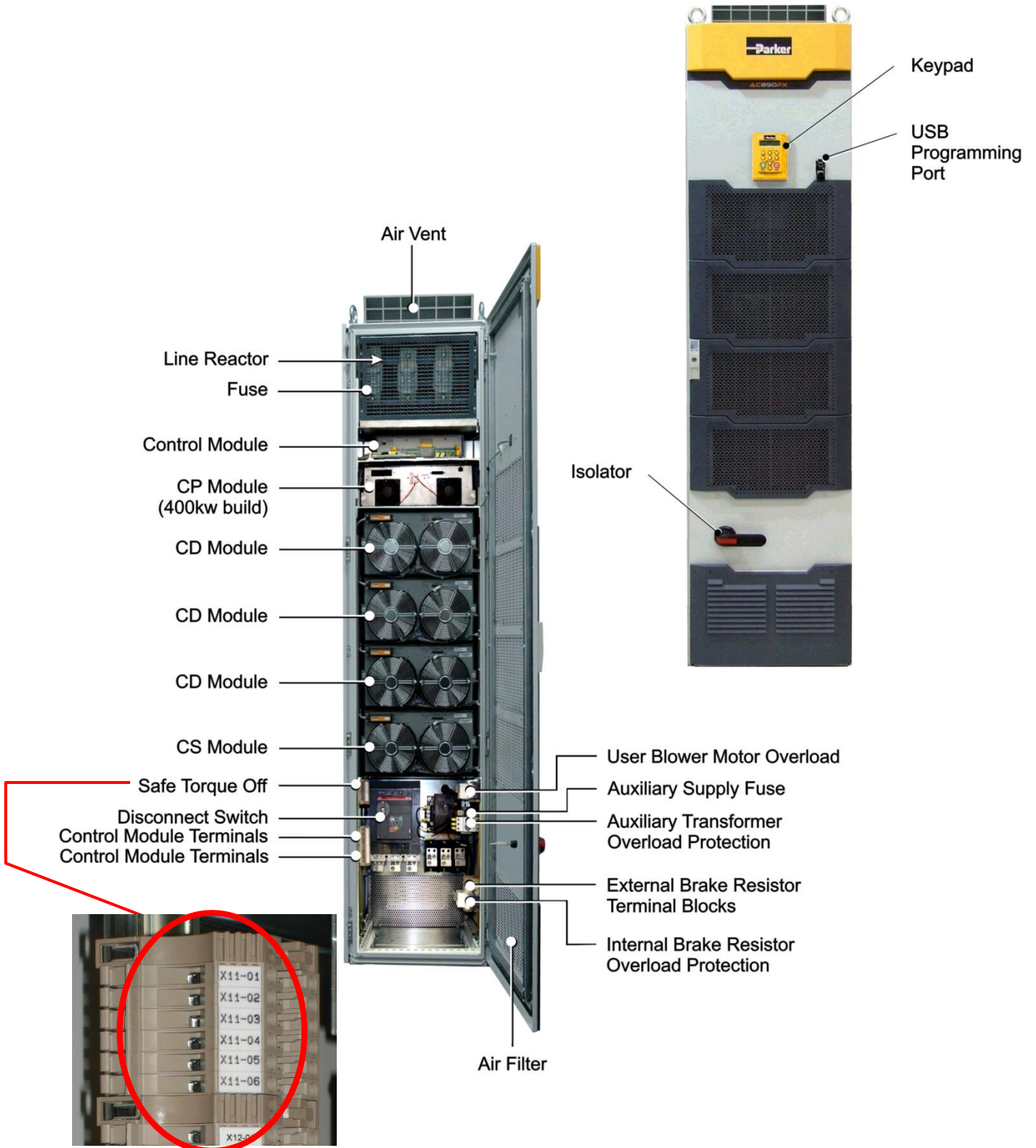

Installation

For European installations and countries with EMC legislation refer to the 890 Engineering Reference Manual, Appendix C.

Mounting Dimensions

With any tall unit such as the AC890PX drive, it is advisable to secure the top to prevent it tipping over.

During operation it must stand vertically on a solid, flat, horizontal, normally cool, non-flammable surface.

The bottom wire entry version of the drive will sit on a plinth (allowing the cables to be fed through the bottom of the drive). In this case, also secure the drive to the plinth.

Refer to Chapter 3: Installation Drawings in the Engineering Reference manual for more information.

Air Flow

It is important that the top vent is properly fitted to assure that the exhaust air is not recirculated.

It is important that air heated by other items should not affect the inlet temperature to the drive's fans.

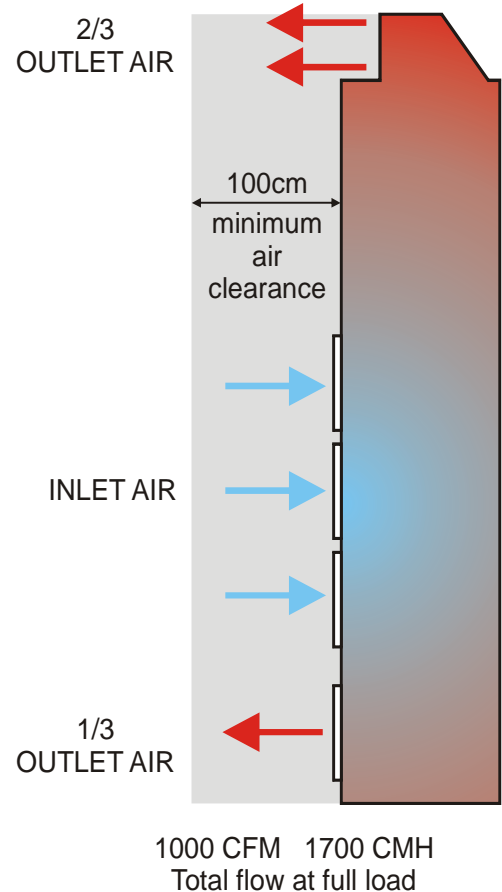

Maximum Weight kg/lbs		Cabinet Height	Cabinet Width	Cabinet Depth	Vent Hood Height
132kW	600lbs (272kg)	2024mm (79.7")	500mm (19.7")	620mm (24.4")	280mm (11.0")
200kW	600lbs (272kg)				
315kW	732lbs (333kg)				
400kW	790lbs (360kg)				

Environmental Conditions

Operating ambient temperature

0°C to 40°C (32°F to 104°F)

Enclosure rating

IP4X – UL(cUL) Enclosed Type 1

Atmosphere

Dust free, non flammable, non-corrosive, <85% humidity, non-condensing

AC890PX Power Connections

Components : Top Wire Entry

- A** Isolator
- B** Control Module/Control Terminals
- C** Auxiliary Transformer
Set the transformer taps - see page 15.
- D** Motor/Output Connections
- E** Protective Earth/Ground
- F** Internal Brake Resistor Thermal Overload Protection
- G** User Blower Motor Thermal Overload Protection
- H** Auxiliary Supply Protection - Circuit Breaker (primary)
- I** Auxiliary Supply Protection - Semiconductor Fuse (secondary)
- J** External Brake Resistor Terminal Block
- K** 3-Phase Connections
- S** X11 Safe Torque Off Terminals



Wiring Diagram : Top Wire Entry

Power Connections

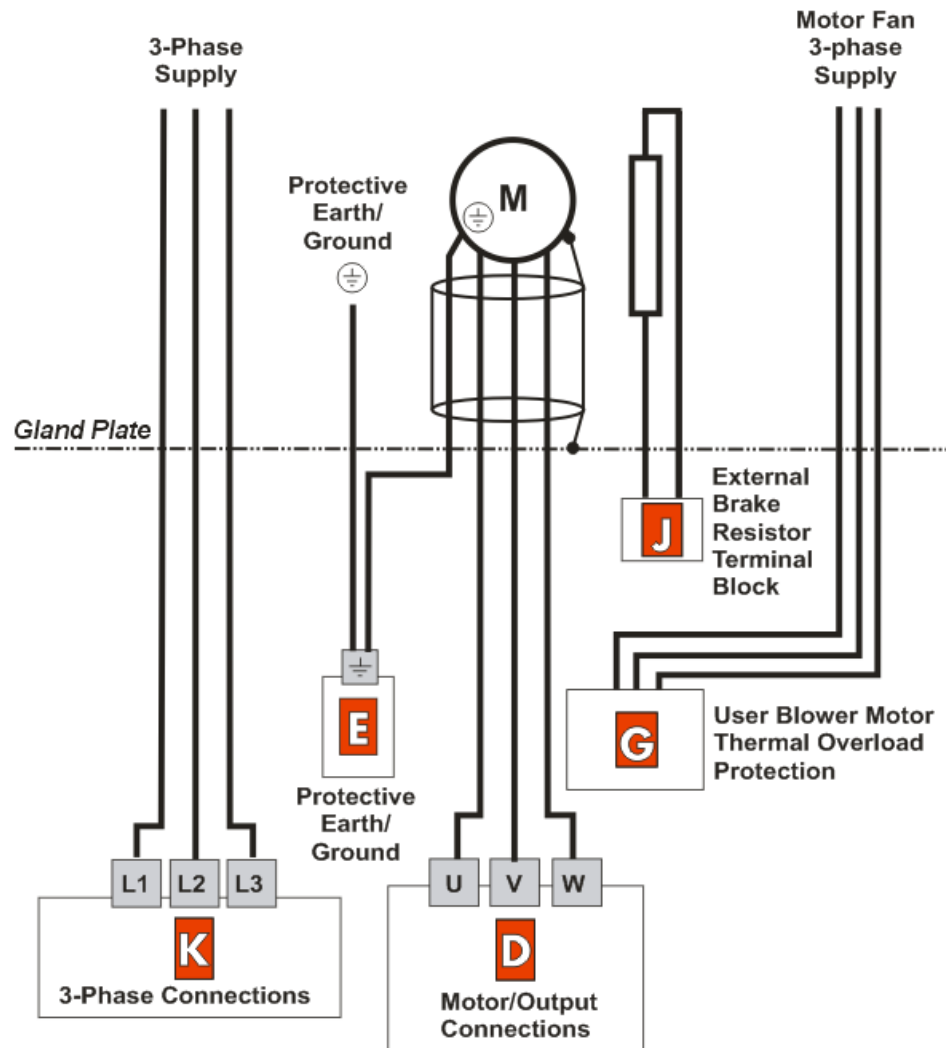

Permanent Earthing

Each unit must be **permanently earthed** according to EN 61800-5. For permanent earthing, EN 61800-5 states that:

A cross-section conductor of at least 10mm² copper or 16mm² aluminum is required.

Conductors must be sized in accordance with Local Wiring Regulations which always take precedence.

As a guide, refer to the Input Current for the drive given in the Electrical Ratings tables.



Components : Bottom Wire Entry

- A** Isolator
- B** Control Module/Control Terminals
- C** Auxiliary Transformer
Set the transformer taps - see page 15.
- D** Motor/Output Connections
- E** Protective Earth/Ground
- F** Internal Brake Resistor Thermal Overload Protection
- G** User Blower Motor Thermal Overload Protection
- H** Auxiliary Supply Protection - Circuit Breaker (primary)
- I** Auxiliary Supply Protection - Semiconductor Fuse (secondary)
- J** External Brake Resistor Terminal Block
- K** 3-Phase Connections
- S** X11 Safe Torque Off Terminals

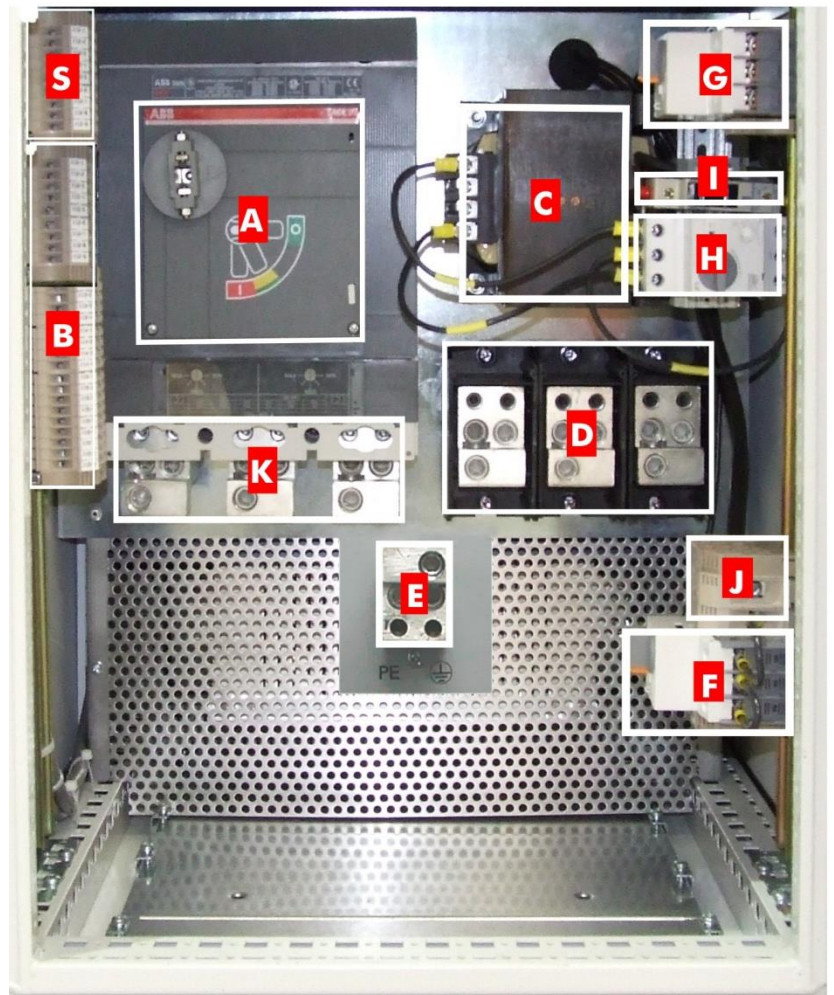

Permanent Earthing

Each unit must be **permanently earthed** according to EN 61800-5. For permanent earthing, EN 61800-5 states that:

A cross-section conductor of at least 10mm² copper or 16mm² aluminum is required.

Conductors must be sized in accordance with Local Wiring Regulations which always take precedence.

As a guide, refer to the Input Current for the drive given in the Electrical Ratings tables.



Wiring Diagram : Bottom Wire Entry

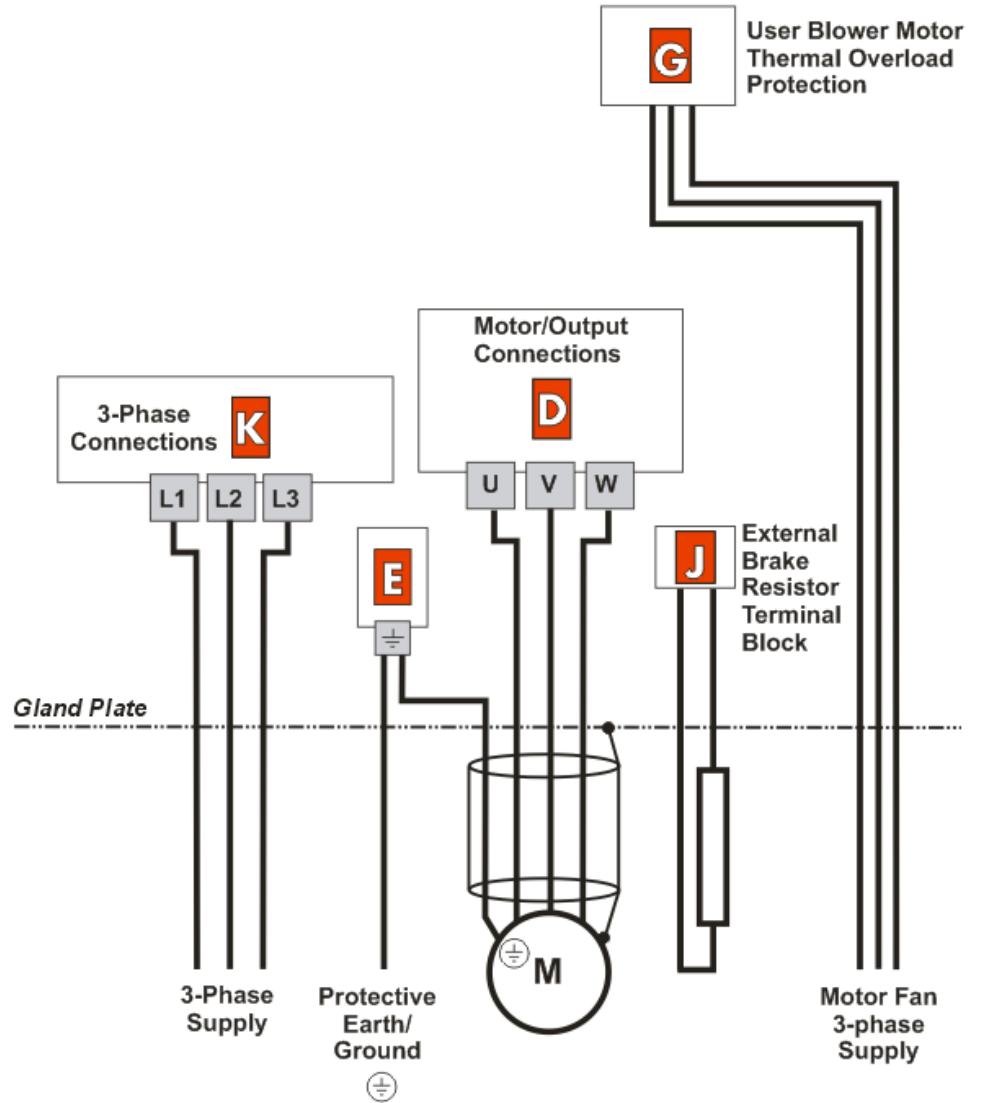

Auxiliary Transformer Taps (C)

The transformer is tapped for no connection, i.e. 0V - PARK when it leaves the factory and the drive will not operate. Either a low voltage or high voltage transformer option is fitted to the drive.

Match the auxiliary transformer tap to the drive's nominal supply voltage. For example, connect the taps to 0V and 400V for a nominal supply voltage of 400Vac.

The transformer supplies a constant 30Vac to the Control Module, internal fans etc. It is protected by a 40A semi-conductor fuse

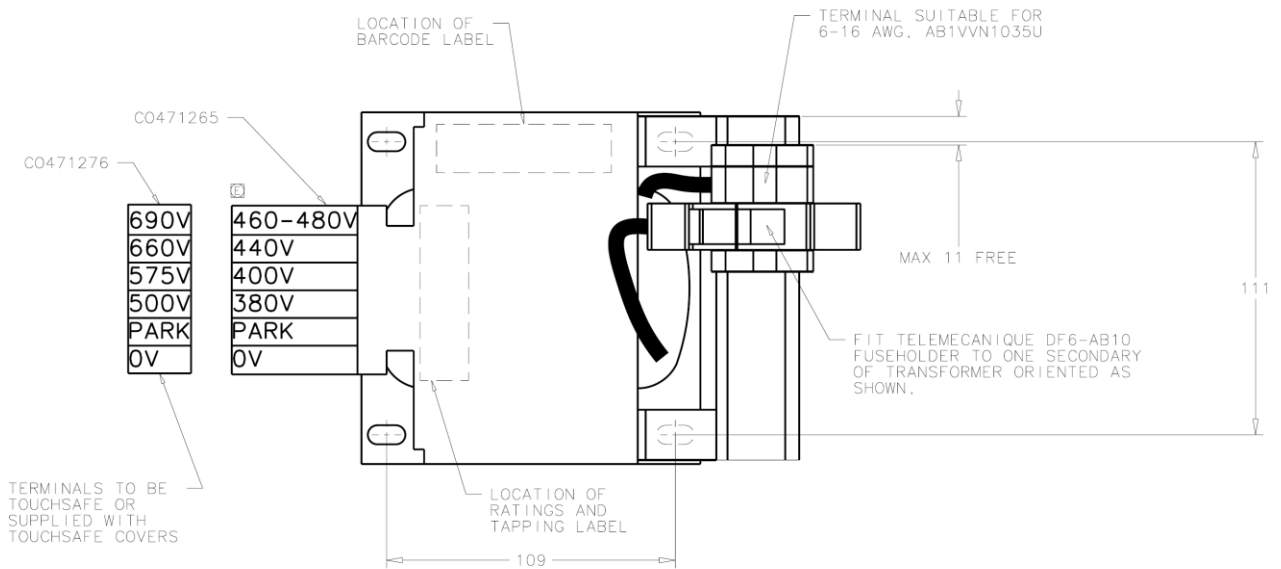
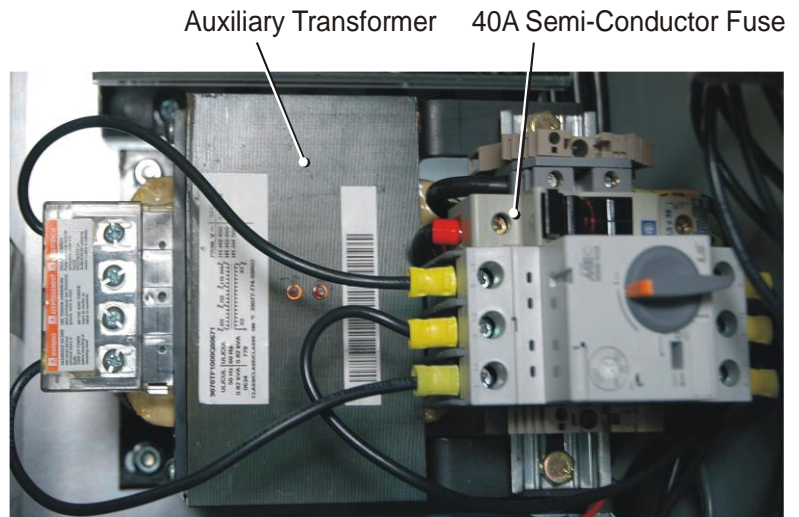

AC890PX Control Connections

A Speed Reference

- Connect a 10kΩ potentiometer at terminal block X12 (Analog I/P 3)
High (CW): terminal X12/08
Wiper: terminal X12/04
Low (CCW): terminal X12/01
- Connect the shield to earth/ground on the drive's metal framework.

OR

- External 2-wire speed reference between terminals X12/01(-) and X12/04(+)
- Connect the shield to earth ground on the drive's metal framework.

B Sequencing

- Connect volt-free contacts as required
- RUN (maintained contact) terminal X14/03 and terminal X15/02

C Thermistor

- Connect motor thermal switch or thermistor to terminals X16/08 & X16/09. Drive will trip when the thermal switch opens, or when the thermistor resistance exceeds 4kΩ maximum (PTC Type A : IEC 34-11 Part 2)
- If the motor does not have a protective device (thermistor), jumper these terminals. The drive needs the thermistor inputs connected for it to run.

Analog

- SPEED FEEDBACK**
10V = ±100% speed at terminal X12/0 6
- TORQUE FEEDBACK**
10V = ±200% torque at terminal X12/07
- ANALOG COMMON**
0V at terminal X12/0 1

Digital

- DRIVE HEALTH**
Relay dry contact (24V rated) at terminal X14/01 and terminal X14/02
- RUNNING**
24V sourcing output at terminal X15/08
- ZERO SPEED**
24V sourcing output at terminal X15/09
- DIGITAL COMMON**
0V at terminal X14/04

D Safe Torque Off

- To disable STO:
Connect X14/03 to X11/01 and X11/03
Connect X14/04 to X11/04 (or X11/02)
 To use the STO feature the user must read and fully understand chapter 4 of the Engineering Reference Manual.
See pages 9 & 11 for STO location.

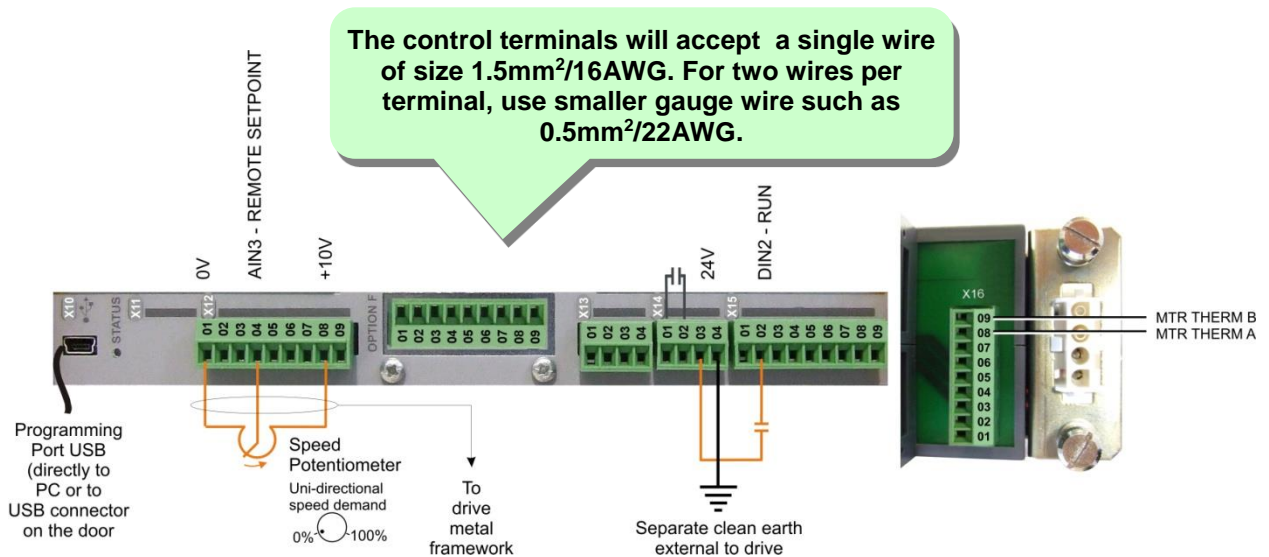

This is a basic connection diagram.

For more detailed information on control connections, refer to Appendix B.

AC890PX Feedback Connections

This section is only for closed loop vector and induction servo applications. Skip this page if there is no encoder or resolver mounted on the motor.

Incremental Pulse Encoders

The default settings for the drive are for 2048 line, quadrature, incremental pulse encoders with differential outputs operating from a 10VDC supply.

- Z channel (Marker pulse) connections are not necessary for running the drive, but inputs are provided for positioning and servo applications. The supply voltage to the encoder is set in the Quick Setup menu. Range 10 VDC to 20 VDC

Use the Keypad to set the following options:

Supply Voltage - PULSE ENC VOLTS

Number of lines per revolution - ENCODER LINES parameter

* Encoder direction - ENCODER INVERT



OPTION F Terminal Block

- 01 Shield
- 02 Supply -
- 03 Supply +
- 04 Channel Z/
- 05 Channel Z
- 06 Channel B/
- 07 Channel B
- 08 Channel A/
- 09 Channel A

* Used to match the encoder direction to the motor direction. When TRUE, changes the sign of the measured speed and the direction of the position count. It is necessary to set up this parameter when in CLOSED-LOOP VEC mode, as the encoder direction must be correct for this mode to operate.

Using other types of encoders requires the 890 DSE Configuration Tool and the setting of other parameters. Refer to the AC890PX Engineering Reference Manual for details of these parameters.

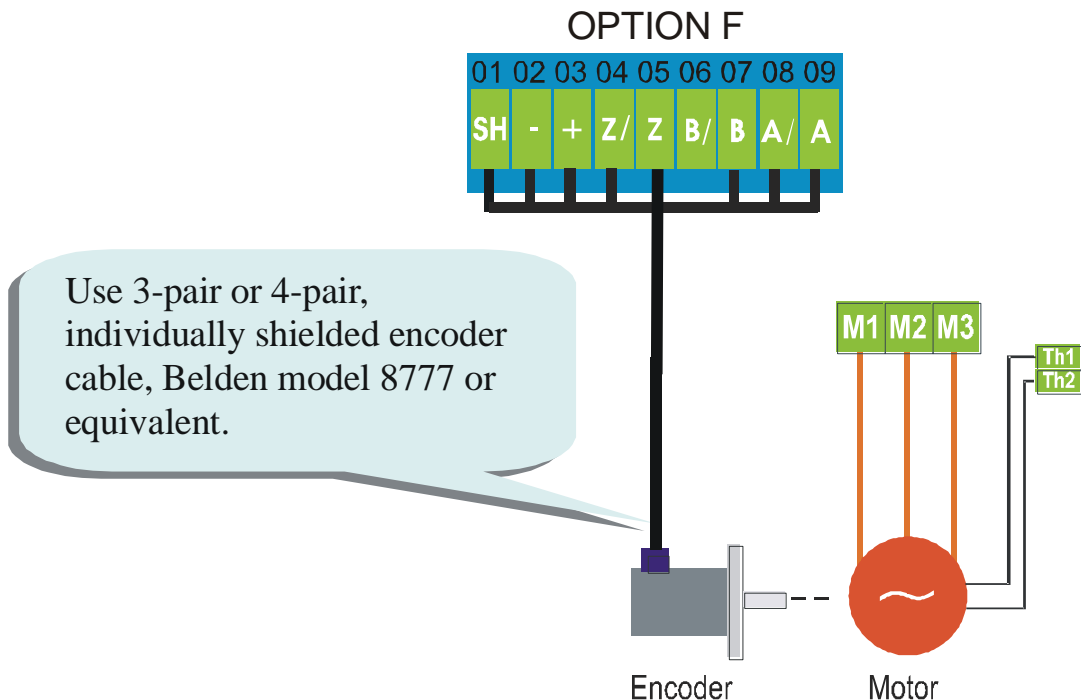

Drive Start-up

Before Applying Power :

- Read the Safety section at the front of the QuickStart.
- Ensure that all local electric codes are met.
- Check for damage to equipment.
- Check for loose ends, clippings, filings, drilling swarf etc., lodged in the drive and system.
- Check all external wiring circuits of the system - power, control, motor and earth connections.
- Ensure that unexpected rotation of the motor in either direction will not result in damage, bodily harm or injury. Disconnect the load from the motor shaft, if possible.
- Check the state of the Motor Thermistor and Brake Resistor connectors. Check external run contacts are open. Check external speed setpoints are all at zero.
- Ensure that nobody is working on another part of the system which will be affected by powering up.
- Ensure that other equipment will not be adversely affected by powering up.
- Check motor stator connections are correctly wired for Star or Delta as necessary for drive output voltage.
- **Check that the STO feature has been disabled. See page 16 of this Quickstart**
- **DANGER: Some motors and control methods are not suitable for use with STO. Refer to Chapter 4 of the Engineering Reference Manual for full details.**

If all connections have been checked, it is time to **POWER-UP the drive**

Drive Set-up

Appendix A contains information about the Keypad menus and parameter names.

Motor Data

Before attempting to set up the drive, you will need some motor information. This is found on the motor nameplate. The information you will need is listed below:

- Base Volts
- Base frequency
- Base RPM
- Full load amps
- No load amps (mag current)
- Connection (star or delta)

Quick Setup Parameters

The following is a list of the Quick Setup parameters you must check before starting the drive. Set only the ones marked with "x" in the table below, under the intended mode of operation.

		V/Hz	SV	Vector	PMAC
Control Mode	Select the intended operating mode	x	x	x	x
Max Speed	Motor RPM at full process speed	x	x	x	x
V/F shape	Usually Linear. Choose fan curve only for fans	x			
Motor Current	Motor full load current from motor nameplate	x	x	x	
Motor Base Freq	Motor nameplate frequency	x	x	x	
Motor Voltage	Motor nameplate voltage	x	x	x	
Nameplate RPM	Motor nameplate RPM	x	x	x	
Motor Poles	<i>See Note</i>		x	x	
Pulse Enc Volts	Set between 10-20V to match encoder			x	
Encoder Lines	Pulses per Revolution of encoder			x	
Encoder Invert	Changes polarity of encoder feedback			x	
Autotune Enable	Drive will Autotune if started		x	x	
Mag Current	Enter the No-Load Amps from the motor nameplate		x*	x*	

- *if performing a Stationary Autotune.*

NOTE Some of the parameters are product code dependent, that is, they are different for each frame size and power rating. For example, the unit will be set for either 50Hz or 60Hz operation:

Motor Poles for 60Hz 2 poles = 3600 rpm, 4 poles = 1800 rpm, 6 poles = 1200 rpm
Motor Poles for 50Hz 2 poles = 3000 rpm, 4 poles = 1500 rpm, 6 poles = 1000 rpm

Autotune

**This section is only for operating in Sensorless or Closed-loop Vector modes.
If the drive is in V/Hz mode, Autotune is unnecessary and will not Enable.**

- Ensure that MAX SPEED is greater than NAMEPLATE RPM for a successful autotune.
- In the QUICK SETUP menu, set AUTOTUNE ENABLE to TRUE.

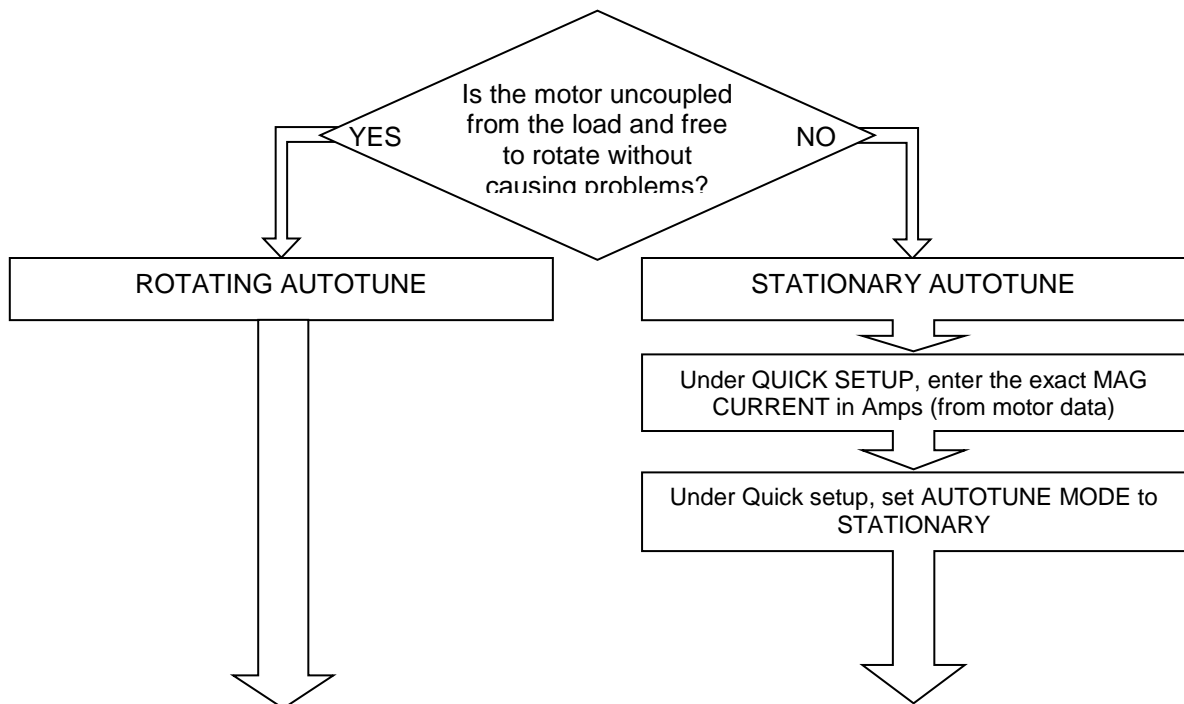

- On the Keypad select LOCAL mode. Set SETPOINT (LOCAL) to 0.0%.
- Press the green RUN button. The drive will begin autotuning. The drive will stop without errors if autotune is successful.
- Go to SYSTEM::SAVE CONFIG::APPLICATION and UP arrow to save your settings.

Running in Local

- On the Keypad select LOCAL mode. The display will show the Local Setpoint : 0.0%
- Use the UP arrow to set a Local Setpoint, say 20%.
- Press the green RUN button. The motor will accelerate to the desired speed and maintain it. Adjust RAMP ACCEL TIME in Quick Setup to the desired level.
- Press the red STOP button. The motor will decelerate to a stop. Adjust RAMP DECEL TIME in Quick Setup to desired level. If the drive trips on Overvoltage, extend the RAMP DECEL TIME or connect a braking resistor. Refer to the AC890PX Engineering Reference Manual.

Go to SYSTEM::SAVE CONFIG::APPLICATION and UP arrow to save your settings Values are stored during power-down.

Running in Remote

- On the keypad select REMOTE mode. The display will show the remote Setpoint : ?.?% (The value displayed depends on the external speed reference).
- Dial in a speed setpoint using the Speed potentiometer until the display reads 20%.
- Start the drive by closing the Start contact between terminal X14/03 and terminal X15/02. The motor will accelerate to the desired speed and maintain it. Adjust RAMP ACCEL TIME in Quick Setup to the desired level.
- Open the Start contact. The motor will decelerate to a stop. Adjust RAMP DECEL TIME in Quick Setup to desired level. If the drive trips on Overvoltage, extend the RAMP DECEL TIME or connect a braking resistor. Refer to the AC890PX Engineering Reference Manual.

Go to SYSTEM::SAVE CONFIG::APPLICATION and UP arrow to save your settings Values are stored during power-down.

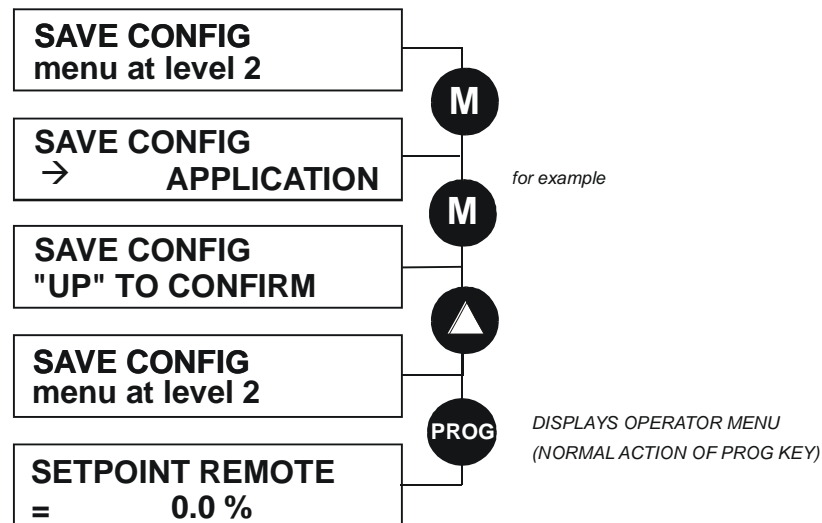

Appendix A: Using the 6901 Keypad

The 6901 keypad has a two-line backlit LCD display with units and symbols. It can be used to setup and configure the AC890PX in plain language. It can also be used to operate the drive in Local mode from its Start and Stop buttons, Jog and reverse.

To display the Software Version and Voltage Rating:

Press **E** repeatedly to display the Welcome Screen

Press **M** to return to the Menus

To Start in Local Mode:

Press **O**

To Stop in Local Mode:

Press **⊙**



SEQ and REF LEDs are On when in Local mode

Menus :	E exit a menu	M sub-menu or parameter	▲ scroll up	▼ scroll down
Parameters :	E exit parameter	M make writable	▲ previous parameter	▼ next parameter
Edit	E stop editing	M show PREF (hold)	▲ increment value	▼ decrement value

The Menu Structure

The main menus are shown below. Each menu contains parameters.



AC MOTOR DRIVE
15kW 400V 1.x

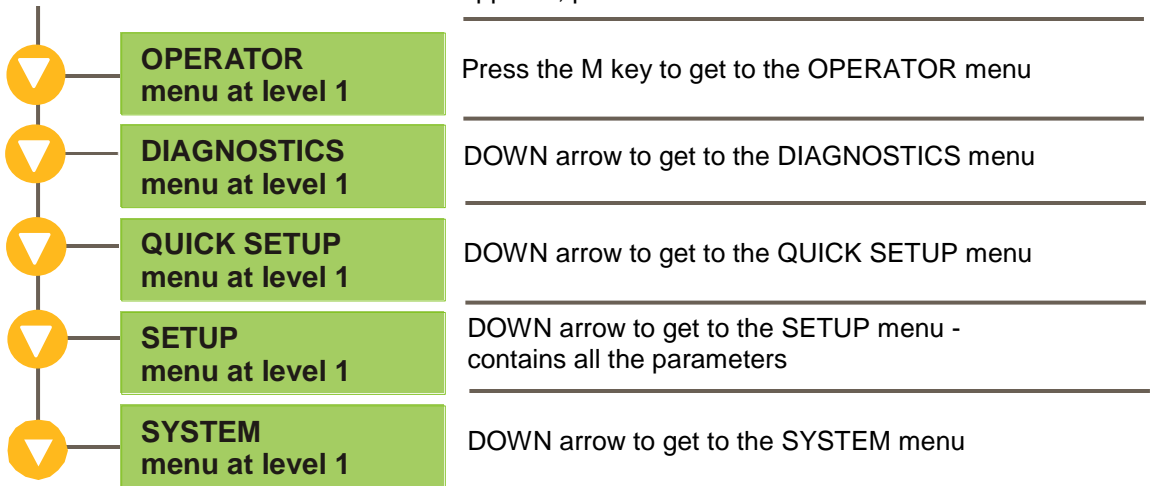

This is the power-up welcome screen. If a different screen appears, press E a few times to return to this screen.

Press the M key to get to the OPERATOR menu

DOWN arrow to get to the DIAGNOSTICS menu

DOWN arrow to get to the QUICK SETUP menu



DOWN arrow to get to the SETUP menu -
contains all the parameters

DOWN arrow to get to the SYSTEM menu

NOTE Refer to the AC890PX Engineering Reference Manual for a list of available parameters.

To change Operating Mode:

From power-up, the keypad displays the Software Version, and then times-out to show the Remote Setpoint.

Mode	Action
Remote to Local	Toggle between modes using the L/R key  SEQ and REF LEDs are On when in Local
Local to Remote	Toggle between modes using the L/R key  SEQ and REF LEDs are Off when in Remote

Appendix B: Analog and Digital I/O

The terminal function names apply to the factory shipping configuration. These terminals may have different functions if the configuration has been modified using DSE.

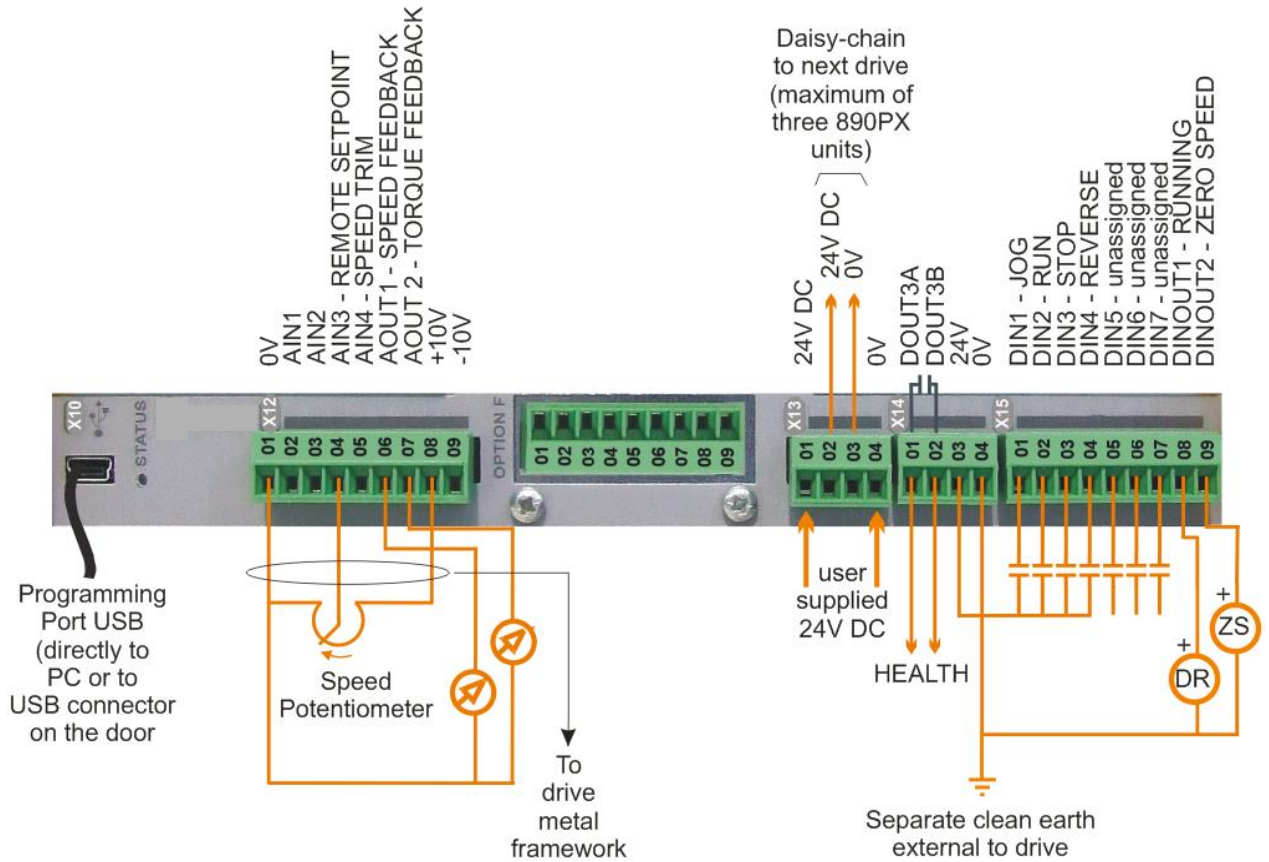

X16

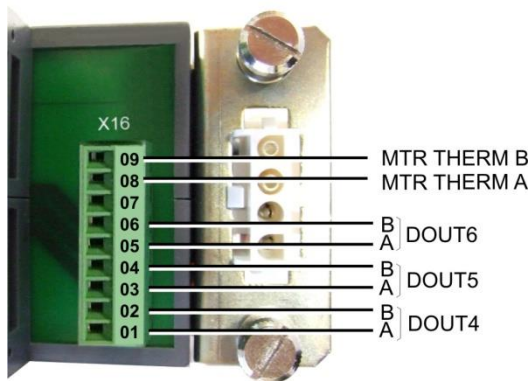

X11



See pages 9 & 11 for STO location.

- X11-01 STO A
- X11-02 0V
- X11-03 STO B
- X11-04 0V
- X11-05 STO STATUS -
- X11-06 STO STATUS+

890PX Control Terminals

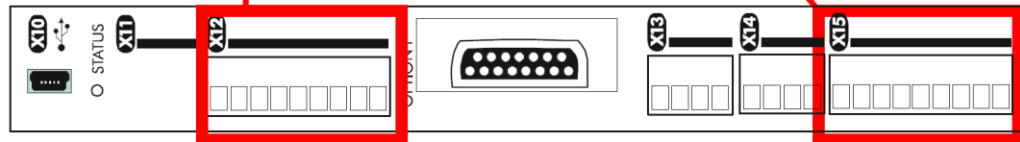

The terminal function names apply to the factory shipping configuration. These terminals may have different functions if the configuration has been modified using DSE.

- Analog I/O connector is X12
- Analog I/O resolution is 12 bit plus sign
- Digital I/O connector is X15
- Digital I/O is 24VDC, sourced, active high

Terminal	Name	Range	Description
ANALOG I/O			
X12/01	0V		0V reference for analog I/O
X12/02	AIN1	0-10V, ±10V	Analog Input 1 Configurable (default = diff I/P +)
X12/03	AIN2	0-10V, ±10V	Analog Input 2 Configurable (default = diff I/P -)
X12/04	AIN3	±10V, 0-10V, 0-20mA, 4-20mA	Analog Input 3 Configurable (default = remote setpoint I/P)
X12/05	AIN4	±10V, 0-10V, 0-20mA, 4-20mA	Analog Input 4 Configurable (default = speed trim I/P)
X12/06	AOUT1	±10V (10V=100%speed)	Analog Output 1 Configurable (default = speed feedback O/P)
X12/07	AOUT2	±10V (10V=200% torque)	Analog Output 2 Configurable (default = torque feedback O/P)
X12/08	+10V REF	+10V	10V reference for analog i/o. Load 10mA maximum
X12/09	-10V REF	-10V	10V reference for analog i/o. Load 10mA maximum
DIGITAL I/O			
X15/01	DIN1	0 or 24V	Configurable Digital Input 1 (default = Jog)
X15/02	DIN2	0 or 24V	Configurable Digital Input 2 (default = Run)
X15/03	DIN3	0 or 24V	Configurable Digital Input 3 (default = Stop)
X15/04	DIN4	0 or 24V	Configurable Digital Input 4 (default = Reverse)
X15/05	DIN5	0 or 24V	Configurable Digital Input 5 (default = Torque mode)
X15/06	DIN6	0 or 24V	Configurable Digital Input 6 (default = Unassigned)
X15/07	DIN7	0 or 24V	Configurable Digital Input 7 (default = Unassigned)
X15/08	DIN8/DOUT1	0 or 24V	Configurable Digital Input/output (default : digital input = Running)
X15/09	DIN9/DOUT2	0 or 24V	Configurable Digital Input/output (default : digital input = Zero Speed)

SAFE TORQUE OFF (STO)

Terminal	Name	Range
X11/01	STO A	To disable STO: connect to X14/03
X11/02	STO 0V	To disable STO: connect to X14/04 *
X11/03	STO B	To disable STO: connect to X14/03
X11/04	STO 0V	To disable STO: connect to X14/04 *
X11/05	STO STATUS -ve	To disable STO: do not connect
X11/06	STO STATUS +ve	To disable STO: do not connect

Description



To use the STO feature, the user must read and fully understand chapter 4 (Safe Torque Off) of the Engineering Reference Manual.

* Connect either X11/02 or X11/04 but not both

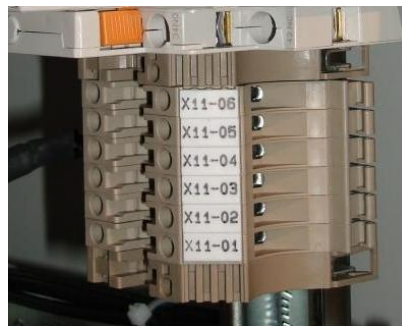
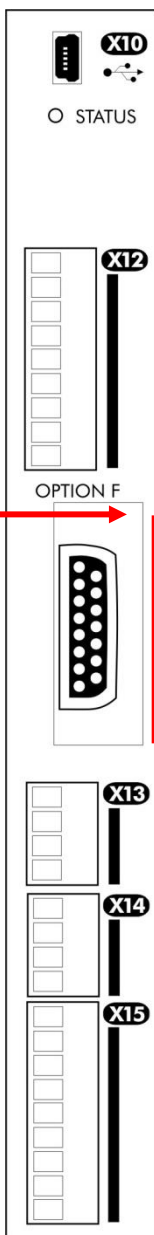

Top Entry

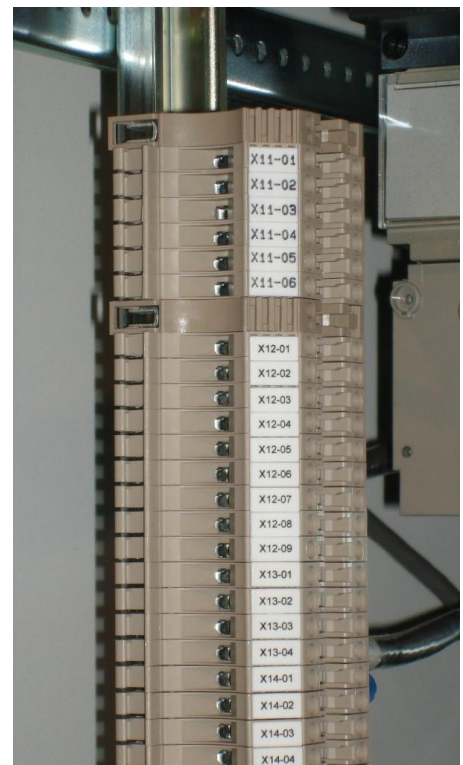

Bottom Entry

Appendix C: Compliance

A comprehensive guide to product compliance is available in the full product manual.

Warning Where there is a conflict between EMC and safety requirements personnel safety shall always take precedence.

Operation of this equipment requires detailed installation and operation instructions provided in the installation/operation manual intended for use on this product. This information should be retained with this device at all times.

Caution: This is a product of the restricted sales distribution class according to IEC 61800-3. It is designated as “professional equipment” as defined in EN61000-3. Permission of the supply authority shall be obtained before connection to the low voltage supply.

In a domestic environment this product may cause radio interference in which case supplementary mitigation measures may be required.

This equipment contains electrostatic discharge (ESD) sensitive parts. Observe static control precautions when handling, installing and servicing this product.

EMC Emissions

Radiated Emissions comply with EN61800-3 category C1 in an environment that gives 10db attenuation between frequencies 80-100MHz, and C2 when installed in accordance with instruction in chapter 3 refer to “Mounting Drives”.

Conducted Emissions comply with EN61800-3 category C3.

Immunity complies with the requirement of EN61800-3, for equipment intended for use in the second environment.

EMC Connections

For compliance with the EMC requirements, the “0V/signal ground” is to be separately earthed. When a number of units are used in a system, these terminals should be connected together at a single, local earthing point.

Control and signal connections should be made with screened cables, with the screen connected only at the VSD end. However, if high frequency noise is still a problem, earth screen at the non VSD end via a 0.1µF capacitor.

Note: Connect the control and signal screens (at the VSD end) to the VSD protective earth point, and not to the control board terminals.

Motor cables should have a 360° bond to ensure a low impedance connection, as per the figure below;

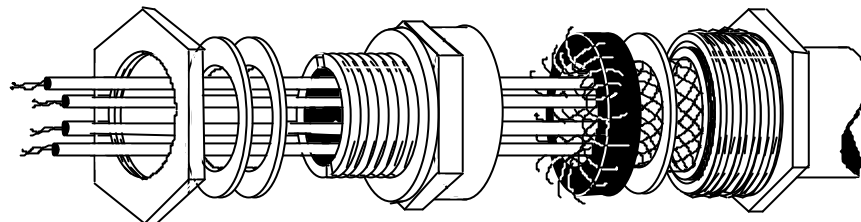

Planning Cable Runs

- ◆ Use the shortest possible motor cable lengths.

- ◆ Use a single length of cable to a star junction point to feed multiple motors.
- ◆ Keep electrically noisy and sensitive cables apart. If this is not possible parallel cable runs should be separated by at least 0.25 meters, for runs longer than 10 meters, separation should be increased proportionally.
- ◆ Sensitive cables should cross noisy cables at 90°.
- ◆ Never run sensitive cables close or parallel to the motor, dc link and braking chopper circuit for any distance.
- ◆ Never run supply, dc link or motor cables in the same bundle as the signal/control and feedback cables, even if they are screened.
- ◆ Ensure EMC filter input and output cables are separately routed and do not couple across the filter.

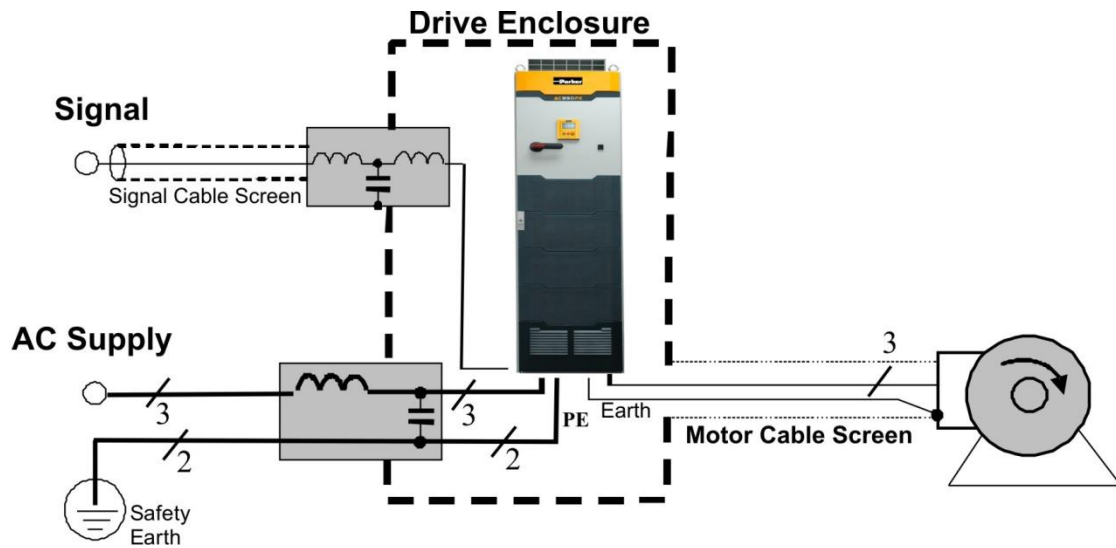

Appendix D: Electrical Ratings

Notes for Electrical Ratings

Read these notes in conjunction with the following ratings tables.

1. **IMPORTANT : The AC890PX is supplied with an in-built Reactor/AC Line Choke providing 3% line impedance.** This is assumed in the quoted input current values.
2. 3Ø input currents given in the table are calculated as:
 - Power Supply: 3Ø, 380-460Vac ±10%, 45-65Hz:
 - 400V nominal 400Vac @ 50Hz ac for kW ratings
 - 460V ac @ 60Hz ac for Hp ratings
 - Power Supply: 3Ø, 500-575V ac ±10%, 45-65Hz:
 - 600V nominal 575Vac @ 60Hz ac for Hp ratings
 - 690V ac @ 50Hz ac for kW ratings
 - Power Supply: 3Ø, 600-690Vac ±10%, 45-65Hz:
 - 700V nominal 575Vac @ 60Hz ac for Hp ratings
 - 690V ac @ 50Hz ac for kW ratings
3. Maximum Switching Frequency: true value given in the table, note that the MMI will display 3kHz.
4. Heavy Duty : Output Overload Motoring 150% for 60s
Normal Duty : Output Overload Motoring 110% for 60s
5. Input Power Factor : 0.94
6. Output Voltage (maximum) = Input Voltage
7. Output Frequency :
 - 0-1000Hz : V/Hz mode
 - 0-350Hz : closed loop vector mode
 - 0-120Hz : sensorless vector mode
8. Fan Inlet Temperature Range : 0-40°C, 32-140°F (drive)
9. Earth Leakage Current : >>100mA.
Product must be permanently earthed.
10. Suitable for earth referenced (TN) and non-earth referenced (IT) supplies.
11. Motor power, output current and input current must not be exceeded under steady state operating conditions.
12. Short circuit protection Semiconductor Fuses are installed in the 3-phase supply to the input module to protect the input bridge. Circuit breakers or HRC fuses will not protect the input bridge.
13. The drives have complied with Certification Agencies requirements and the voltage ratings carry the following Safety Marks:
 - 380-460V : CE, UL, cUL
 - 500-575V : CE, UL, cUL
 - 600-690V : CE, (UL - 600V only)

Electrical Ratings (380-460V)

		Units		890PX/4/0215/		890PX/4/0260/		890PX/4/0300/		890PX/4/0420/		890PX/4/0480/		890PX/4/0520/		890PX/4/0580/	
Maximum Prospective Short Circuit Current		KA	65	KA	65	KA	65	KA	65	KA	65	KA	65	KA	65	KA	65
HEAVY DUTY																	
USA/Canada		Europe															
Nominal Input Voltage	(note 2)	V	400	V	400	V	400	V	400	V	400	V	400	V	400	V	400
Motor Power	(note 4)	HP	150	HP	200	HP	250	HP	300	HP	300	HP	400	HP	400	HP	500
Output Current	(notes 1 & 2)	A	200	A	250	A	300	A	380	A	460	A	460	A	580	A	580
AC Input Current	(note 3)	W	171	W	218	W	272	W	329	W	436	W	436	W	549	W	549
Drive Total Power Loss	(note 3)	KHz	2557	KHz	3166	KHz	3817	KHz	4591	KHz	5716	KHz	5716	KHz	6582	KHz	6582
Maximum Switching Frequency	(note 3)	A ² s	2	A ² s	2	A ² s	2	A ² s	2	A ² s	2	A ² s	2	A ² s	2	A ² s	2
Input Bridge I ² t	(note 2)	V	235000	V	235000	V	235000	V	1200000	V	1200000	V	1200000	V	1200000	V	1200000
Nominal Input Voltage	(note 2)	KW	400	KW	400	KW	400	KW	400	KW	400	KW	400	KW	400	KW	400
Motor Power	(note 4)	A	132	A	160	A	200	A	250	A	250	A	315	A	355	A	400
Output Current	(notes 1 & 2)	W	260	W	340	W	390	W	480	W	600	W	600	W	660	W	720
AC Input Current	(note 3)	KHz	228	KHz	268	KHz	336	KHz	423	KHz	532	KHz	532	KHz	602	KHz	679
Drive Total Power Loss	(note 3)	A ² s	3230	A ² s	4120	A ² s	4877	A ² s	5783	A ² s	7378	A ² s	7378	A ² s	7997	A ² s	8950
Maximum Switching Frequency	(note 2)	V	2	V	2	V	2	V	2	V	2	V	2	V	2	V	2
Input Bridge I ² t	(note 4)	HP	245000	HP	245000	HP	245000	HP	1330000	HP	1330000	HP	1330000	HP	1330000	HP	1330000
Nominal Input Voltage	(notes 1 & 2)	A	460	A	460	A	460	A	460	A	460	A	460	A	460	A	460
Motor Power	(note 3)	W	200	W	250	W	300	W	380	W	480	W	480	W	547	W	659
Output Current	(note 3)	KHz	250	KHz	320	KHz	326	KHz	436	KHz	547	KHz	547	KHz	6131	KHz	6306
AC Input Current	(note 2)	A ² s	222	A ² s	242	A ² s	2771	A ² s	3471	A ² s	4367	A ² s	4367	A ² s	4717	A ² s	4717
Drive Total Power Loss	(note 2)	KA	3148	KA	3870	KA	4771	KA	5879	KA	7417	KA	7417	KA	8894	KA	8894
Maximum Switching Frequency	(note 2)	A ² s	2	A ² s	2	A ² s	2	A ² s	2	A ² s	2	A ² s	2	A ² s	2	A ² s	2
Input Bridge I ² t	(note 2)	KA	235000	KA	235000	KA	235000	KA	1200000	KA	1200000	KA	1200000	KA	1200000	KA	1200000
NORMAL DUTY																	

Electrical Ratings (500-575V & 600-690V)

		Units		890PX/6/0130/ 890PX/7/0130/	890PX/6/0160 890PX/7/0160	890PX/6/0190 890PX/7/0190	890PX/6/0230 890PX/7/0230	890PX/6/0280 890PX/7/0280	890PX/6/0320 890PX/7/0320	890PX/6/0340 890PX/7/0340
Maximum Prospective Short Circuit Current		KA	65	65	65	65	65	65	65	65
Nominal Input Voltage		V	690	690	690	690	690	690	690	690
Motor Power		KW	110	132	160	200	250	280	280	315
Output Current		A	130	160	190	230	280	320	320	340
AC Input Current		A	134	154	177	198	244	277	277	309
Drive Total Power Loss		W	2398	2869	3279	3945	4629	5411	5411	5795
Maximum Switching Frequency		KHz	2	2	2	2	2	2	2	2
Input Bridge I²t		A ² s	245000	245000	245000	720000	720000	720000	720000	720000
Nominal Input Voltage		V	575	575	575	-	575	-	-	575
Motor Power		Hp	150	200	250	-	300	-	-	400
Output Current		A	160	210	260	-	310	-	-	410
AC Input Current		A	144	180	221	-	259	-	-	347
Drive Total Power Loss		W	2857	3510	4456	-	4888	-	-	6432
Maximum Switching Frequency		KHz	2	2	2	-	2	-	-	2
Input Bridge I²t		A ² s	235000	235000	235000	-	820000	-	-	820000
Nominal Input Voltage		V	690	690	690	690	690	690	690	690
Motor Power		KW	132	160	200	250	315	355	355	400
Output Current		A	160	190	240	280	340	390	390	430
AC Input Current		A	157	177	210	244	305	347	347	389
Drive Total Power Loss		W	2717	3206	4213	4753	5777	6613	6613	7333
Maximum Switching Frequency		KHz	2	2	2	2	2	2	2	2
Input Bridge I²t		A ² s	245000	245000	245000	720000	720000	720000	720000	720000
Nominal Input Voltage		V	575	575	575	-	575	-	-	575
Motor Power		Hp	200	250	300	-	400	-	-	500
Output Current		A	210	250	310	-	420	-	-	480
AC Input Current		A	182	180	264	-	344	-	-	432
Drive Total Power Loss		W	3634	4059	5285	-	6582	-	-	7648
Maximum Switching Frequency		KHz	2	2	2	-	2	-	-	2
Input Bridge I²t		A ² s	235000	235000	235000	-	820000	-	-	820000

Parker Worldwide

AE – UAE, Dubai
Tel: +971 4 8127100
parker.me@parker.com

AR – Argentina, Buenos Aires
Tel: +54 3327 44 4129

AT – Austria, Wiener Neustadt
Tel: +43 (0)2622 23501-0
parker.austria@parker.com

AT – Eastern Europe, Wiener Neustadt
Tel: +43 (0)2622 23501 900
parker.eastereurope@parker.com

AU – Australia, Castle Hill
Tel: +61 (0)2-9634 7777

AZ – Azerbaijan, Baku
Tel: +994 50 2233 458
parker.azerbaijan@parker.com

BE/LU – Belgium, Nivelles
Tel: +32 (0)67 280 900
parker.belgium@parker.com

BR – Brazil, Cachoeirinha RS
Tel: +55 51 3470 9144

BY – Belarus, Minsk
Tel: +375 17 209 9399
parker.belarus@parker.com

CA – Canada, Milton, Ontario
Tel: +1 905 693 3000

CH – Switzerland, Etoy
Tel: +41 (0)21 821 87 00
parker.switzerland@parker.com

CL – Chile, Santiago
Tel: +56 2 623 1216

CN – China, Shanghai
Tel: +86 21 2899 5000

CZ – Czech Republic, Klecany
Tel: +420 284 083 111
parker.czechrepublic@parker.com

DE – Germany, Kaarst
Tel: +49 (0)2131 4016 0
parker.germany@parker.com

DK – Denmark, Ballerup
Tel: +45 43 56 04 00
parker.denmark@parker.com

ES – Spain, Madrid
Tel: +34 902 330 001
parker.spain@parker.com

FI – Finland, Vantaa
Tel: +358 (0)20 753 2500
parker.finland@parker.com

FR – France, Contamine s/Arve
Tel: +33 (0)4 50 25 80 25
parker.france@parker.com

GR – Greece, Athens
Tel: +30 210 933 6450
parker.greece@parker.com

HK – Hong Kong
Tel: +852 2428 8008

HU – Hungary, Budapest
Tel: +36 1 220 4155
parker.hungary@parker.com

IE – Ireland, Dublin
Tel: +353 (0)1 466 6370
parker.ireland@parker.com

IN – India, Mumbai
Tel: +91 22 6513 7081-85

IT – Italy, Corsico (MI)
Tel: +39 02 45 19 21
parker.italy@parker.com

JP – Japan, Tokyo
Tel: +81 (0)3 6408 3901

KR – South Korea, Seoul
Tel: +82 2 559 0400

KZ – Kazakhstan, Almaty
Tel: +7 7272 505 800
parker.eastereurope@parker.com

MX – Mexico, Apodaca
Tel: +52 81 8156 6000

MY – Malaysia, Shah Alam
Tel: +60 3 7849 0800

NL – The Netherlands, Oldenzaal
Tel: +31 (0)541 585 000
parker.nl@parker.com

NO – Norway, Asker
Tel: +47 66 75 34 00
parker.norway@parker.com

NZ – New Zealand, Mt Wellington
Tel: +64 9 574 1744

PL – Poland, Warsaw
Tel: +48 (0)22 573 24 00
parker.poland@parker.com

PT – Portugal, Leca da Palmeira
Tel: +351 22 999 7360
parker.portugal@parker.com

RO – Romania, Bucharest
Tel: +40 21 252 1382
parker.romania@parker.com

RU – Russia, Moscow
Tel: +7 495 645-2156
parker.russia@parker.com

SE – Sweden, Spånga
Tel: +46 (0)8 59 79 50 00
parker.sweden@parker.com

SG – Singapore
Tel: +65 6887 6300

SK – Slovakia, Banská Bystrica
Tel: +421 484 162 252
parker.slovakia@parker.com

SL – Slovenia, Novo Mesto
Tel: +386 7 337 6650
parker.slovenia@parker.com

TH – Thailand, Bangkok
Tel: +662 717 8140

TR – Turkey, Istanbul
Tel: +90 216 4997081
parker.turkey@parker.com

TW – Taiwan, Taipei
Tel: +886 2 2298 8987

UA – Ukraine, Kiev
Tel: +380 44 494 2731
parker.ukraine@parker.com

UK – United Kingdom, Warwick
Tel: +44 (0)1926 317 878
parker.uk@parker.com

US – USA, Cleveland
Tel: +1 216 896 3000

VE – Venezuela, Caracas
Tel: +58 212 238 5422

ZA – South Africa, Kempton Park
Tel: +27 (0)11 961 0700
parker.southafrica@parker.com

European Product Information Centre

Free phone: 00 800 27 27 5374

(from AT, BE, CH, CZ, DE, EE, ES, FI, FR, IE, IL, IS, IT, LU, MT, NL, NO, PT, SE, SK, UK)

© 2016 Parker Hannifin Corporation. All rights reserved.

Parker Hannifin Manufacturing Limited, Automation Group, Electromechanical Drives Business Unit,

New Courtwick Lane, Littlehampton,
West Sussex BN17 7RZ
United Kingdom

Tel: +44(0)1903 737000

Fax: +44(0)1903 737100

www.parker.com/ssd



* H A 4 7 1 6 6 5 0 0 0 0 6 *