



Visit us at [www.SSDrives.com](http://www.SSDrives.com)  
 USA: (704) 588-3246 UK: +44 (0)1903 737000  
 HA470679U200 Issue 7

### 650V Quick Start Frames C - F

Sensorless Vector  
Volts/Hertz Inverters

- aerospace
- climate control
- electromechanical
- filtration
- fluid & gas handling
- hydraulics
- pneumatics
- process control
- sealing & shielding



ENGINEERING YOUR SUCCESS.

## BEFORE YOU START

This document covers the steps necessary for a basic start up of the 650V drive. Drive start ups should be performed by qualified electrical technicians who are familiar with AC drives and their applications. For detailed installation and safety information refer to the Installation Manual. For advanced features and applications, refer to the Software Manual.

Ensure that all local electric codes are met while installing the drive. Check that all live parts are covered to protect against electric shock and that unexpected rotation of the motor will not result in bodily harm or injury.

This document expects that the drive is already installed in its intended location and that all relevant installation procedures have been followed. Please ensure that the drive has adequate ventilation so that ambient temperature does not exceed 45°C (112°F) under normal operating conditions.

To access the terminals, loosen the two retaining screws at the bottom of the drive, pull up gently on the terminal cover and slide it off.

## CONTROL MODES

**Volts/Hertz mode** – Basic open loop operation, used in fans/pumps and multi-motor applications.

**Sensorless Vector mode** – Tight speed regulation with good transient torque capability, without the need for speed feedback.

## POWER CONNECTIONS

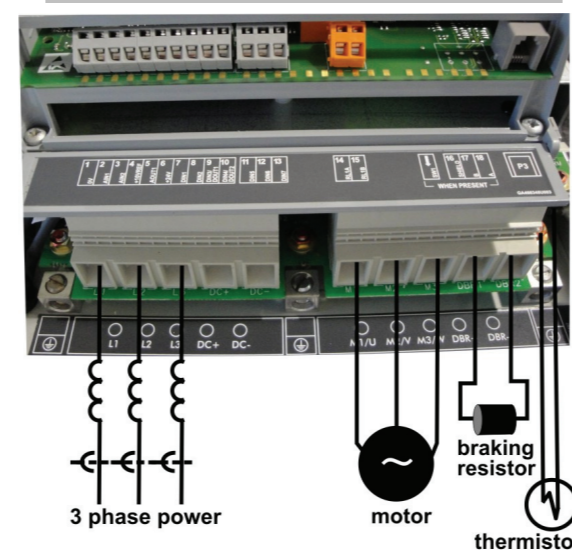

The power terminals shown are for frame D. Although other frames may vary slightly in appearance, their terminal designations and functionality are identical. However, the Frame F unit requires an auxiliary supply for the cooling fan. Refer to Chapter 3.

- 3-phase supply to L1, L2, L3.
- Motor connections to M1, M2, M3
- Brake resistor between DBR+, DBR-
- Motor thermistor to MOT TEMP
- Common Bus to DC+, DC-
- Frame F only: 115/230V fan supply to L,N

Ground lugs have been provided for each of the power circuits. Follow proper grounding and shielding methods as described in chapter 3 of the Installation Manual.

If the stop time is expected to be less than the natural coasting time of the load, order the factory mounted braking module option on frames D through F. Frame C has a built-in braking module. Connect the braking resistor across DBR+ and DBR-.

## REFERENCE AND SEQUENCING

- Speed potentiometer: 1 (Low), 4 (High), 2 (Wiper) OR
- External speed reference: 1(-) and 2(+)

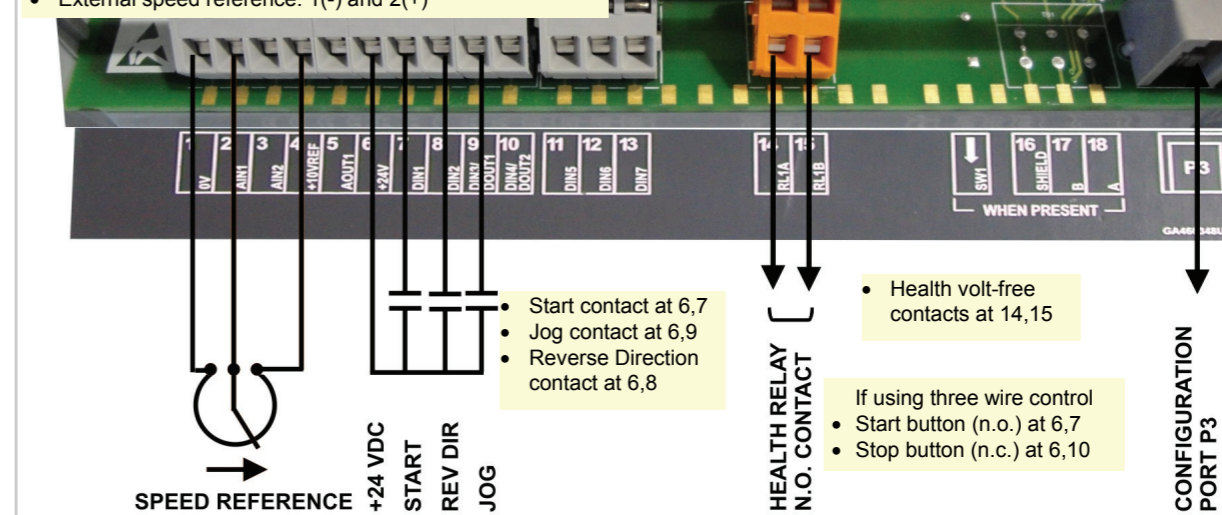

## CALIBRATION

All calibration is done in software, through the keypad

**DIAGNOSTICS**

|    |                |                           |
|----|----------------|---------------------------|
| d1 | Frequency      | Output frequency (Hz)     |
| d2 | Speed Setpoint | Speed SP (% of Max Speed) |
| d3 | DC Link Volts  | Voltage of DC Bus         |
| d4 | Motor Current  | Motor Current (amps)      |

The drive powers up in **LOCAL MODE**. Use the green/red buttons to start/stop and the up/down arrows to adjust speed. To switch to **REMOTE MODE**, hold the STOP button down until **LDC** disappears. To revert to **LOCAL MODE**: At the **rdy** screen, push STOP until **LDC** appears.

**SETUP PARAMETERS**

|     |                    |                                       |
|-----|--------------------|---------------------------------------|
| P1  | Application Select | Select the application macro          |
| P2  | Max Speed          | Set max speed in Hz                   |
| P3  | Min Speed          | Set min speed in %                    |
| P4  | Acceleration time  | Accel time to Max Speed in sec        |
| P5  | Deceleration time  | Decel time from Max Speed in sec      |
| P6  | Motor Current      | Motor full load current in amps       |
| P7  | Base Frequency     | Motor nameplate frequency in Hz       |
| P8  | Jog Setpoint       | Set jog speed in % of max speed       |
| P9  | Stop Mode          | 0=Ramp; 1=Coast; 2=Injection braking  |
| P11 | V/Hz shape         | 0=Linear; 1=Quadratic (fan or square) |
| P12 | Overload Rating    | 0=150% for 30s.; 1=110% for 10s.      |
| P13 | Fixed Boost        | Set boost in % volts (V/Hz mode only) |
| P99 | Password           | Set from 0001 to FFFF for protection  |

**SAVING**  
Changes take effect as soon as they are entered and parameters are saved automatically in a few seconds

## CLONING

650V drives may be cloned using the 6514 Clone option that plugs into the keypad port. Settings include to/from, I/O configuration and full/part transfer.



## SERIAL COMMS

The Serial Communication option is factory installed and must be ordered with the drive. It can be used to exchange information between the Master and Slave drives in RS485/232 format. Up to 32 units can be connected together.

## ADVANCED FEATURES

The 650V has additional features which can be accessed via the drive menu or using DSELite. Refer to the product manual for details.

**Flycatching** - When enabled, lets the drive start into a spinning load by doing a frequency search.

**Skip Frequencies** - Two selectable avoidance frequencies and associated window for each.

**PID** - Provides closed loop process control

**S-Ramp** - When enabled, introduces a second order slope to the ramp for smoother transitions.

**Configurable Outputs** - The digital outputs on the 650V can be configured to pick one of 6 parameters. The outputs on the 650V are totally configurable.

**Auto Restart** - After a fault, the drive attempts a number of restarts after a settable delay.

**Custom Screens** - Allows the use of a Custom parameter to be displayed.

**Encoder** - Terminals 12 & 13 can be used for a quadrature (not complementary) encoder input for steady-state speed feedback.

**Associated Literature**  
 650V Installation Manual HA467652Uxxx  
 650V Software Manual HA466358Uxxx

## COMPLIANCE

A comprehensive guide to product compliance is available in the full product manual.

**Warning** - Where there is a conflict between EMC and safety requirements personnel safety shall always take precedence. Operation of this equipment requires detailed installation and operation instructions provided in the installation/operation manual intended for use on this product. This information is provided on the CD ROM included in the container this device was packaged in. It should be retained with this device at all times.

**Caution:** This is a product of the restricted sales distribution class according to IEC 61800-3. It is designated as "professional equipment" as defined in EN61000-3. Permission of the supply authority shall be obtained before connection to the low voltage supply.

In a domestic environment this product may cause radio interference in which case supplementary mitigation measures may be required.

This equipment contains electrostatic discharge (ESD) sensitive parts. Observe static control precautions when handling, installing and servicing this product.

### EMC Emissions

#### Radiated Emissions

The 650 series frame C-F is required to be installed in an enclosure with no apertures of dimensions greater than 0.15m, providing 10dBs attenuation between 30-1000MHz to ensure compliance with EN61800-3, category C1, unrestricted distribution, when used with a recommended ac supply filter.

#### Conducted Emissions

The 650 frame C-F comply with EN61800-3, category C1, unrestricted distribution with a maximum cable length of 50m, when used with a recommended ac supply filter.

### EMC Connections

For compliance with the EMC requirements, the "0V/signal ground" is to be separately earthed. When a number of units are used in a system, these terminals should be connected together at a single, local earthing point. Control and signal connections should be made with screened cables, with the screen connected only at the VSD end. However, if high frequency noise is still a problem, earth screen at the non VSD end via a 0.1µF capacitor. **Note:** Connect the control and signal screens (at the VSD end) to the VSD protective earth point, and not to the control board terminals.

Motor cables should have a 360° bond to ensure a low impedance connection, as per the figure below;

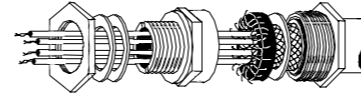

### Planning Cable Runs

- Use the shortest possible motor cable lengths.
- Use a single length of cable to a star junction point to feed multiple motors.
- Keep electrically noisy and sensitive cables apart. If this is not possible parallel cable runs should be separate by at least 0.25 meters, for runs longer than 10 meters, separation should be increased proportionally.
- Sensitive cables should cross noisy cables at 90°.
- Never run sensitive cables close or parallel to the motor, dc link and braking chopper circuit for any distance.
- Never run supply, dc link or motor cables in the same bundle as the signal/control and feedback cables, even if they are screened.
- Ensure EMC filter input and output cables are separately routed and do not couple across the filter.

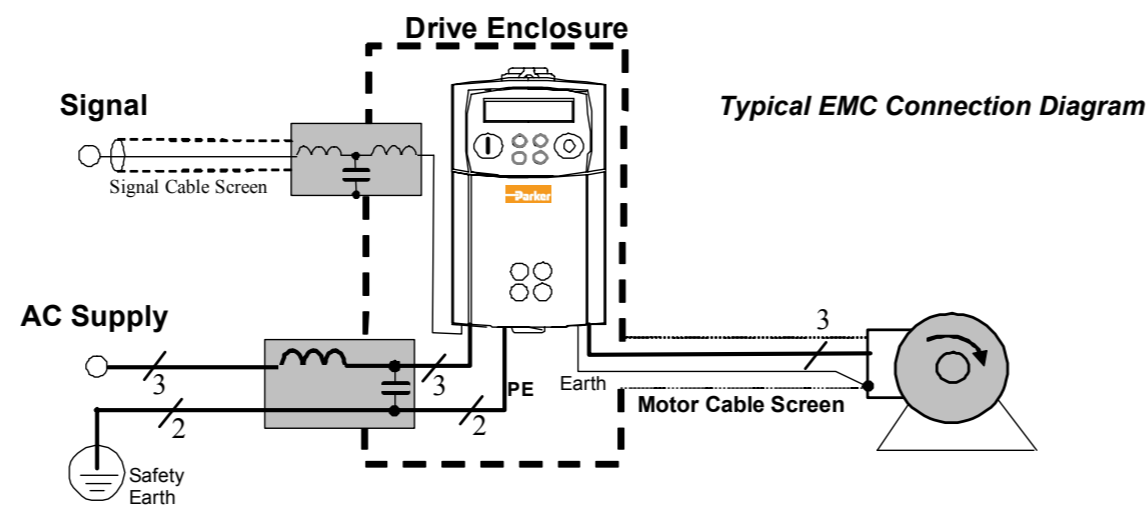

## APPLICATION MACROS

After the first power-up, the 650 defaults to the most basic mode of operation, namely speed control. In addition, it has the capability of being configured for special applications by loading the correct Application Macro.

**Selecting an Application:** Applications may be loaded during power-up by pressing and holding the STOP button, or by setting P1 from the Parameters menu. 1=Speed Control; 2=Manual/Auto; 3=Preset Speeds; 4=Raise/Lower; 5=PI Control; 9=Custom (650Vonly).

**Terminal Assignments:** Different applications require different setup parameters, inputs and outputs. When an application is selected, the 650 internally reassigns its control terminals for the relevant functionality. Also, depending on the application selected, an enhanced application-specific set of parameters will be visible, in addition to the regular parameters.

|                                | SPEED CONTROL<br>P1=1  | MANUAL/AUTO<br>P1=2  | PRESET SPEEDS<br>P1=3  | RAISE/LOWER<br>P1=4   | PI CONTROL<br>P1=5  |
|--------------------------------|--|--|--|---|---|
| <b>App-Specific Parameters</b> | None   | IP23 ANIN2 type<br>OP21 DIGIO2<br>OP31 Relay   | IP301 Preset 1<br>IP302 Preset 2<br>IP303 Preset 3<br>IP304 Preset 4<br>IP305 Preset 5<br>IP306 Preset 6<br>IP307 Preset 7<br>IP308 Preset 8                                       | P401 Ramp Time<br>P402 Max Value<br>P403 Min Value<br>P404 Reset Value  | P501 Prop. Gain<br>P502 Integral Gain   |
| <b>Control Terminal Assign</b> | 1 Common 0V<br>2 Speed In (V)<br>3 Speed In (mA)<br>4 +10V Supply<br>5 Speed Output<br>6 +24V Supply<br>7 Start button<br>8 Fwd/Rev<br>9 Jog<br>10 Stop button | 1 Common 0V<br>2 Manual Ref (V)<br>3 Auto Ref (mA)<br>4 +10V Supply<br>5 Speed Output<br>6 +24V Supply<br>7 Manual Start<br>8 Auto Start<br>9 Man/Auto<br>10 Fwd/Rev | 1 Common 0V<br>2 Speed In (V)<br>3 Speed In (mA)<br>4 +10V Supply<br>5 Speed Output<br>6 +24V Supply<br>7 Start<br>8 Preset Digital 1<br>9 Preset Digital 2<br>10 Preset Digital 3 | 1 Common 0V<br>2 Unused<br>3 Unused<br>4 +10V Supply<br>5 Speed Output<br>6 +24V Supply<br>7 Start<br>8 Raise Input<br>9 Lower Input<br>10 Ramp Reset | 1 Common 0V<br>2 Reference (V)<br>3 Feedback (mA)<br>4 +10V Supply<br>5 Speed Output<br>6 +24V Supply<br>7 Start button<br>8 Fwd/Rev<br>9 Jog<br>10 Stop button |

## AUTOTUNE

Autotune will not activate if in V/Hz mode.

For sensorless vector (SV) operation, an autotune is highly recommended, preferably with the motor uncoupled and free to rotate. (if the motor cannot be uncoupled, set CL20=0. See below).

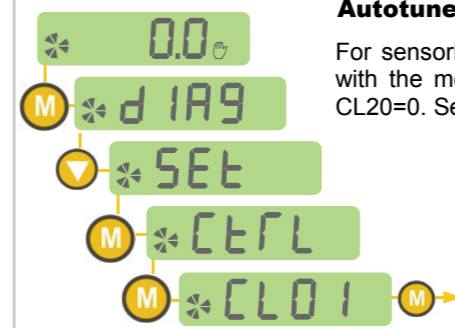

### CONTROL PARAMETERS

|                      |   |
|----------------------|---|
| CL01 Control Mode    | 0 = V/Hz; 1 = Sensorless Vector (SV)      |
| CL02 Nameplate RPM   | Enter RPM from motor nameplate            |
| CL10 Motor Current   | Enter full load amps from motor nameplate |
| CL11 Motor Poles     | 2=3600rpm; 4=1800rpm; 6=1200rpm           |
| CL12 Motor Voltage   | Enter motor nameplate voltage             |
| CL20 Autotune Mode   | 0=stationary; 1=rotating (preferred)      |
| CL21 Autotune Enable | set to 1 and run the drive to autotune    |
| CL81 Current Limit   | Current Limit setting as a % of CL10      |