

- CV Check Valves
- SH Shuttle Valves
- LM Load/Motor Controls
- FC Flow Controls
- PC Pressure Controls
- LE Logic Elements
- DC Directional Controls
- SV Solenoid Valves
- PV Proportional Valves
- CE Coils & Electronics
- BC Bodies & Cavities
- TD Technical Data

General Description

Direct Acting, Normally Closed Sequence Valve with External Pilot and Drain. For additional information see Technical Tips on pages PC1-PC4.

Features

- Hardened working parts for maximum durability
- All external parts zinc plated
- Adjustable and tamperproof versions available

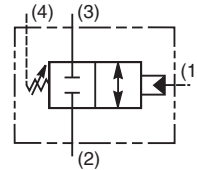
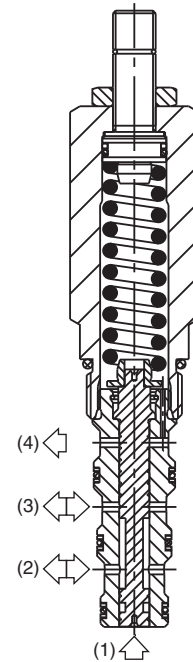
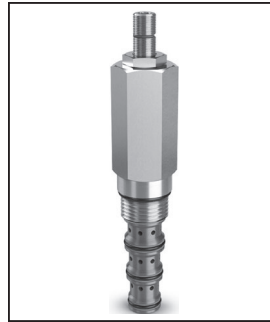

Specifications

Rated Flow	47 LPM (12 GPM)
Maximum Inlet Pressure	420 Bar (6000 PSI)
Maximum Pressure Setting	G - 2-166 Bar (30-2400 PSI)
Sensitivity: Pressure/Turn	G - 17 Bar (248 PSI)
Maximum Tank Pressure	420 Bar (6000 PSI)
Leakage at 150 SSU (32 cSt)	25 ml/min. @ 100 Bar (1450 PSI)
Cartridge Material	All parts steel. All operating parts hardened steel.
Fluid Compatibility/ Viscosity	Mineral-based or synthetic with lubricating properties at viscosities of 45 to 2000 SSU (6 to 420 cSt)
Filtration	ISO-4406 18/16/13, SAE Class 4
Approx. Weight	0.33 kg (0.73 lbs.)
Cavity	C10-4 (See BC Section for more details)
Form Tool	Rougher NFT10-4R Finisher NFT10-4F

Performance Curves

(Pressure rise through cartridge only)

Flow vs. Inlet Pressure 2 to 3

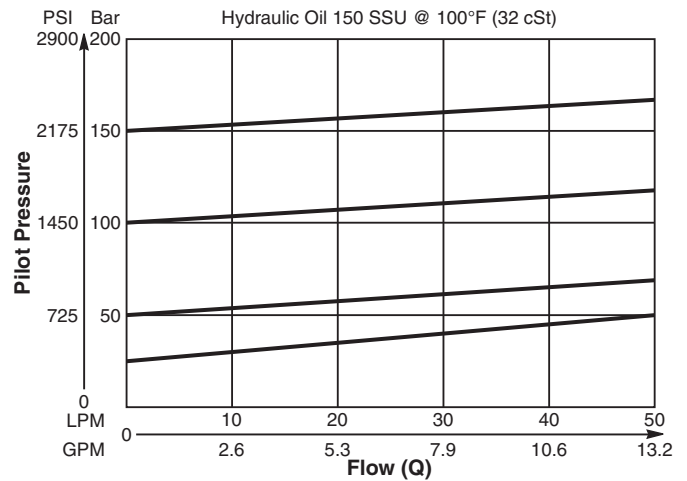

Pressure Drop vs. Flow 3 to 2

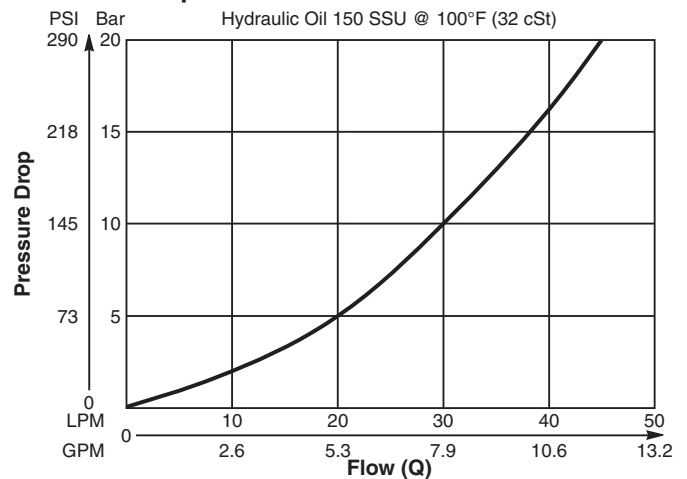

Dimensions Millimeters (Inches)

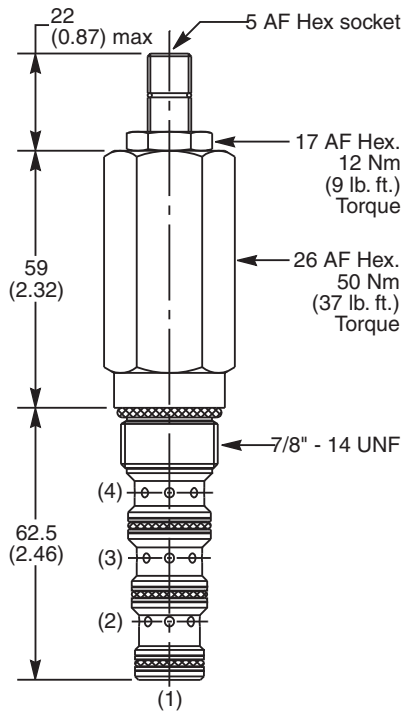

Ordering Information

B04H4	G	Z	N
10 Size D.A. Sequence Valve (External Pilot and Drain)	Pilot Pressure Adjustment Range	Adjustment Style	Seals

Code	Pilot Pressure Adjustment Range
G	2 - 166 Bar (30 - 2400 PSI)

Pilot Switching Pressure
B04H4G Standard Setting: 80 Bar (1160 PSI) @ 5 LPM (1.3 GPM)

*Order Bodies Separately
See section BC*

B10	—	4	—	8B
10 Size		4-Way Cavity		Port Size

Code	Adjustment Style
Z	Screw Adjust

*Valves are supplied at Standard setting.
Other settings are available, please
contact Parker Sales.*

Port Size
1/2" BSP

Body Material
Steel

Code	Seals / Kit No.	Operating Temp.
N	Nitrile, Buna-N / (SK30506N-1)	-34°C to +121°C (-30°F to +250°F)

- CV** Check Valves
- SH** Shuttle Valves
- LM** Load/Motor Controls
- FC** Flow Controls
- PC** Pressure Controls
- LE** Logic Elements
- DC** Directional Controls
- SV** Solenoid Valves
- PV** Proportional Valves
- CE** Coils & Electronics
- BC** Bodies & Cavities
- TD** Technical Data