

- CV Check Valves
- SH Shuttle Valves
- LM Load/Motor Controls
- FC Flow Controls
- PC Pressure Controls
- LE Logic Elements
- DC Directional Controls
- SV Solenoid Valves
- PV Proportional Valves
- CE Coils & Electronics
- BC Bodies & Cavities
- TD Technical Data

## General Description

Kick-Down, Spool Type, Pilot Operated Sequence Valve. For additional information see Technical Tips on pages PC1-PC4.

## Features

- High flow capacity
- Integral 250 micron pilot flow filter
- Hardened working parts for maximum durability
- Adjustable and tamperproof versions available
- All external parts zinc plated

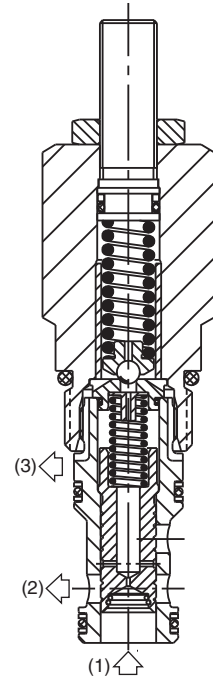
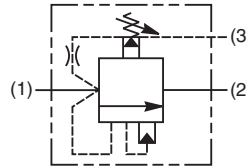
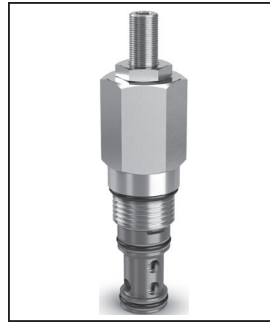

## Specifications

<b>Rated Flow</b>	160 LPM (42 GPM)
<b>Maximum Inlet Pressure</b>	420 Bar (6000 PSI)
<b>Maximum Pressure Setting</b>	P - 10-420 Bar (145-6000 PSI)
<b>Sensitivity: Pressure/Turn</b>	P - 55 Bar (800 PSI)
<b>Maximum Tank Pressure</b>	420 Bar (6000 PSI)
<b>Cartridge Material</b>	All parts steel. All operating parts hardened steel.
<b>Fluid Compatibility/ Viscosity</b>	Mineral-based or synthetic with lubricating properties at viscosities of 45 to 2000 SSU (6 to 420 cSt)
<b>Filtration</b>	ISO-4406 18/16/13, SAE Class 4
<b>Approx. Weight</b>	0.27 kg (0.55 lbs.)
<b>Cavity</b>	C10-3S (See BC Section for more details)
<b>Form Tool</b>	Rougher NFT10S-3R Finisher NFT10S-3F

## Performance Curve

(Pressure rise through cartridge only)

### Pressure Drop vs. Flow 1 to 2

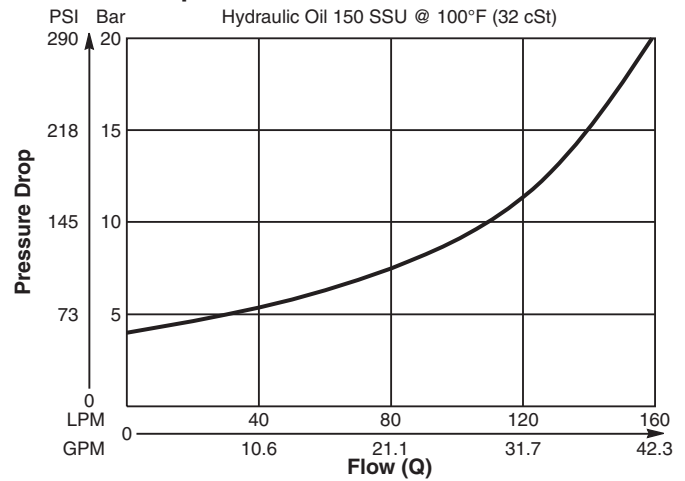

## Application Note

Valve unloads completely when setting is reached and resets when fluid supply is removed.

**Dimensions** Millimeters (Inches)

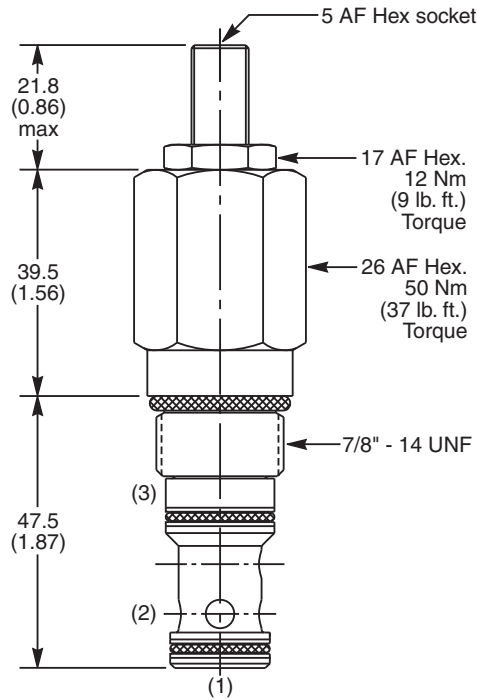

**Ordering Information**

<b>B04C3</b>	<b>P</b>	<b>Z</b>	<b>N</b>
10 Size Kick-Down Pilot Operated Sequence Valve	Pressure Adjustment Range	Adjustment Style	Seals

Code	Pressure Adjustment Range
P	10 - 420 Bar (145 - 6000 PSI)

Standard Pressure Setting
<b>B04C3P</b> Standard Setting: 200 Bar (2900 PSI)

*Order Bodies Separately  
See section BC*

<b>LB10</b>	<b>711</b>	<b>S</b>
Line Body	Porting	Body Material

Code	Adjustment Style
Z	Screw Adjust

*Valves are supplied at Standard setting.  
Other settings are available, please  
contact Parker Sales.*

Code	Porting
711	3/4" BSP (main) 1/4" BSP (aux)

Code	Seals / Kit No.	Operating Temp.
N	Nitrile, Buna-N / (SK30504N-1)	-34°C to +121°C (-30°F to +250°F)

Code	Body Material
S	Steel

<b>CV</b>
Check Valves
<b>SH</b>
Shuttle Valves
<b>LM</b>
Load/Motor Controls
<b>FC</b>
Flow Controls
<b>PC</b>
Pressure Controls
<b>LE</b>
Logic Elements
<b>DC</b>
Directional Controls
<b>SV</b>
Solenoid Valves
<b>PV</b>
Proportional Valves
<b>CE</b>
Coils & Electronics
<b>BC</b>
Bodies & Cavities
<b>TD</b>
Technical Data