

General Description

Diverter Valve, Normally Closed, 2-Way with External Pilot and Vent.

Features

- High flow capacity
- Two switching pressures available
- Sealed pilot option available
- Hardened working parts for maximum durability
- All external parts zinc plated

Performance Curve

Pressure Drop vs. Flow (Through cartridge only)

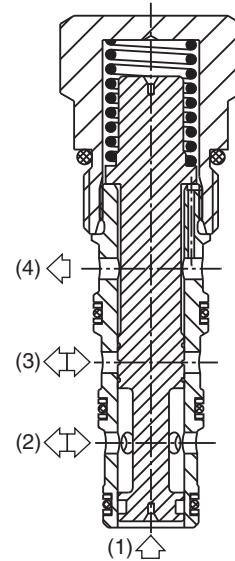
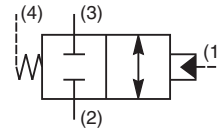
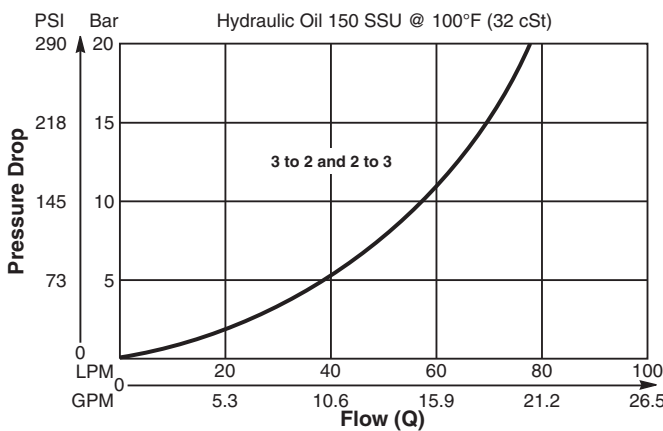

Dimensions Millimeters (Inches)

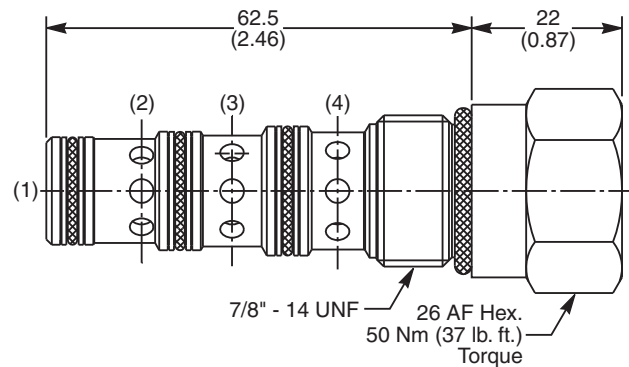

Specifications

Rated Flow	80 LPM (21 GPM)
Nominal Flow @ 7 Bar (100 PSI)	47 LPM (12 GPM)
Maximum Inlet Pressure	420 Bar (6000 PSI)
Pilot Switching Pressure	See ordering information
Cartridge Material	All parts steel. All operating parts hardened steel.
Fluid Compatibility/ Viscosity	Mineral-based or synthetic with lubricating properties at viscosities of 45 to 2000 SSU (6 to 420 cSt)
Filtration	ISO-4406 18/16/13, SAE Class 4
Approx. Weight	.17 kg (.37 lbs.)
Cavity	C10-4 (See BC Section for more details)

Ordering Information

R04B4 — **Pilot Switching Pressure** — **N** — **Seals** — **Sealed Pilot**

10 Size Diverter Valve **Seals** **Sealed Pilot**

Order Bodies Separately See section BC

Code	Switching Pressure
5.0	5.0 Bar (73 PSI) Std.
10.0	10.0 Bar (145 PSI)

If no switching pressure is specified, valve will be supplied as R04B4-5.0N

Code	Sealed Pilot
Omit	If not required
S	Sealed Pilot

Port Size	Body Material
1/2" BSP	Steel

Code	Seals / Kit No.	Operating Temp.
N	Nitrile, Buna-N / (SK30506N-1)	-34°C to +121°C (-30°F to +250°F)

B10 — **4** — **8B**

10 Size **4-Way Cavity** **Port Size**

- CV** Check Valves
- SH** Shuttle Valves
- LM** Load/Motor Controls
- FC** Flow Controls
- PC** Pressure Controls
- LE** Logic Elements
- DC** Directional Controls
- SV** Solenoid Valves
- PV** Proportional Valves
- CE** Coils & Electronics
- BC** Bodies & Cavities
- TD** Technical Data

