

- CV** Check Valves
- SH** Shuttle Valves
- LM** Load/Motor Controls
- FC** Flow Controls
- PC** Pressure Controls
- LE** Logic Elements
- DC** Directional Controls
- MV** Manual Valves
- SV** Solenoid Valves
- PV** Proportional Valves
- CE** Coils & Electronics
- CB** Cartridge Bodies
- BC** Bodies & Cavities
- TD** Technical Data

General Description

Cartridge Style Check Valve.
 For additional information see Technical Tips on pages CV1-CV2.

Features

- Hardened, precision ground parts for durability
- Fully guided poppet for smooth operation
- All external parts zinc plated

Performance Curve

Pressure Drop vs. Flow (Through cartridge only)

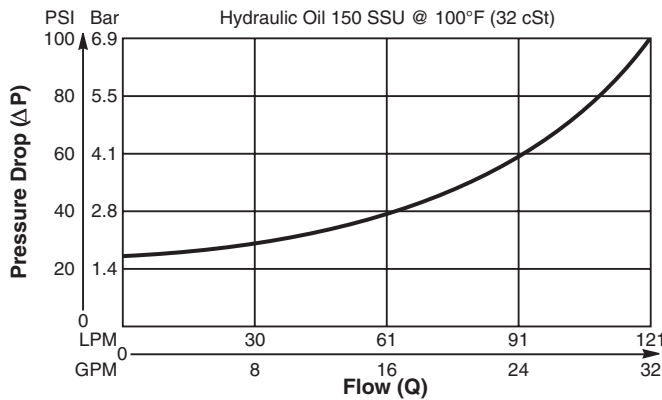

Specifications

Rated Flow	121 LPM (32 GPM)
Maximum Inlet Pressure	350 Bar (5000 PSI)
Leakage at 150 SSU (32 cSt)	5 drops/min. (0.33 cc/min) at 350 Bar (5000 PSI)
Cartridge Material	All parts steel. All operating parts hardened steel.
Operating Temp. Range/Seals	-34°C to +121°C (Nitrile) (-30°F to +250°F) -26°C to +204°C (Fluorocarbon) (-15°F to +400°F)
Fluid Compatibility/Viscosity	Mineral-based or synthetic with lubricating properties at viscosities of 45 to 2000 SSU (6 to 420 cSt)
Filtration	ISO-4406 18/16/13, SAE Class 4
Approx. Weight	0.14 kg (0.30 lbs.)
Cavity	C12-2 (See BC Section for more details)
Form Tool	Rougher None Finisher NFT12-2F

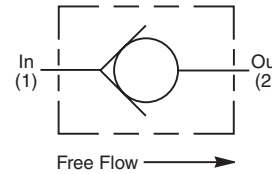
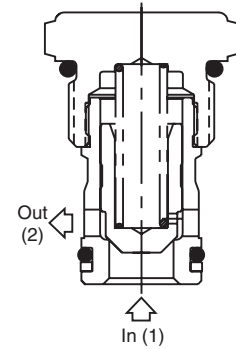

Dimensions

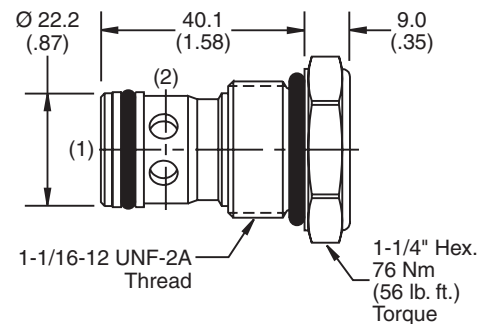

Ordering Information

CVH121P

12 Size Check Valve **Cracking Pressure** **Seals**

Highlighted represents preferred options that offer the shortest lead times. Other options may be available, but at extended lead times.

Code	Cracking Pressure
Omit	1.7 Bar (25 PSI)
03	0.2 Bar (3 PSI)
05	0.35 Bar (5 PSI)
65	4.5 Bar (65 PSI)

Code	Seals / Kit No.
N	Nitrile / (SK12-2)
V	Fluorocarbon / (SK12-2V)

Order Bodies Separately
 See section BC

B12 - **2** -

12 size 2-Way Cavity Port Size

Code	Porting / Body Material
12T	SAE-12 / Steel (5000 PSI)
A12T	SAE-12 / Aluminium (3000 PSI)