

**Technical Information**

- CV** Check Valves
- SH** Shuttle Valves
- LM** Load/Motor Controls
- FC** Flow Controls
- PC** Pressure Controls
- LE** Logic Elements
- DC** Directional Controls
- MV** Manual Valves
- SV** Solenoid Valves
- PV** Proportional Valves
- CE** Coils & Electronics
- BC** Bodies & Cavities
- TD** Technical Data

**General Description**

Two Position, Three Way, Spring Centered Shuttle Valve. For additional information see Technical Tips on pages SH1-SH2.

**Features**

- High flow capacity
- Various switching pressures available
- Hardened working parts for maximum durability
- All external parts zinc plated

**Performance Curve**

**Pressure Drop vs. Flow (Through cartridge only)**

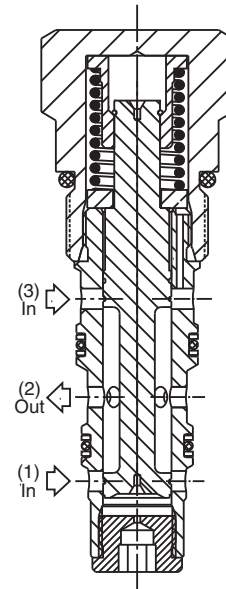
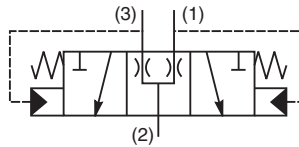
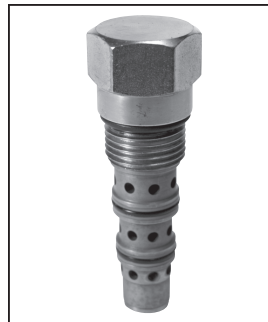
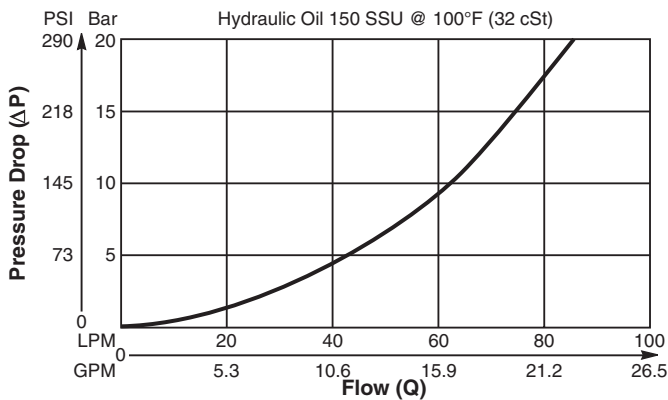

**Dimensions** Millimeters (Inches)

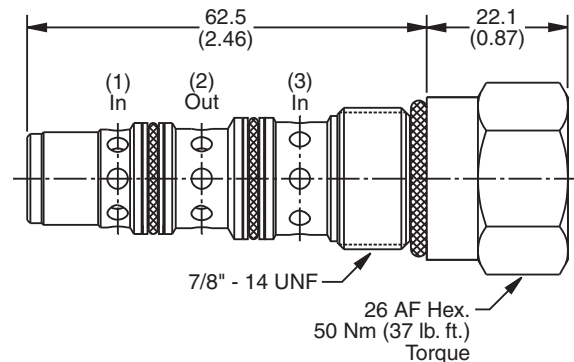

**Specifications**

<b>Rated Flow</b>	100 LPM (26 GPM)
<b>Nominal Flow @ 7 Bar (100 PSI)</b>	55 LPM (15 GPM)
<b>Maximum Inlet Pressure</b>	420 Bar (6000 PSI)
<b>Cartridge Material</b>	All parts steel. All operating parts hardened steel.
<b>Operating Temp. Range/Seals</b>	-34°C to +121°C (Nitrile, Buna-N) (-30°F to +250°F) -26°C to +204°C (Fluorocarbon) (-15°F to +400°F)
<b>Fluid Compatibility/Viscosity</b>	Mineral-based or synthetic with lubricating properties at viscosities of 45 to 2000 SSU (6 to 420 cSt)
<b>Filtration</b>	ISO-4406 18/16/13, SAE Class 4
<b>Approx. Weight</b>	.17 kg (.37 lbs.)
<b>Cavity</b>	C10-4 (See BC Section for more details)

**Ordering Information**

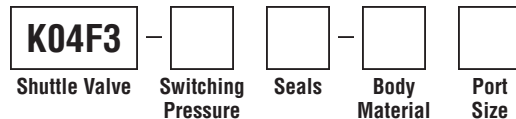

Code	Switching Pressure
0.0	0 Bar (0 PSI)
2.5	2.5 Bar (36 PSI)
5.0	5.0 Bar (73 PSI) Std.
10.0	10.0 Bar (145 PSI)

Code	Body Material
Omit	Steel
A	Aluminum

Code	Seals / Kit No.
N	Nitrile, Buna-N / (SK30504N-1)
V	Fluorocarbon / (SK30504V-1)

Code	Port Size	Body Part No.
Omit	Cartridge Only	
6T	SAE-6	(B10-4-*6T)
8T	SAE-8	(B10-4-*8T)

\* Add "A" for aluminum, omit for steel.

