

Technical Information

- CV** Check Valves
- SH** Shuttle Valves
- LM** Load/Motor Controls
- FC** Flow Controls
- PC** Pressure Controls
- LE** Logic Elements
- DC** Directional Controls
- MV** Manual Valves
- SV** Solenoid Valves
- PV** Proportional Valves
- CE** Coils & Electronics
- BC** Bodies & Cavities
- TD** Technical Data

General Description

Direct Acting, Normally Open Sequence Valve with External Pilot and Internal Drain. For additional information see Technical Tips on pages PC1-PC6.

Features

- Sealed pilot option available
- Hardened working parts for maximum durability
- All external parts zinc plated
- Adjustable and tamperproof versions available

Specifications

Rated Flow	40 LPM (10.6 GPM)
Maximum Inlet Pressure	420 Bar (6000 PSI)
Maximum Pressure Setting	E - 2-80 Bar (30-1160 PSI) G - 2-166 Bar (30-2400 PSI) J - 40-240 Bar (580-3500 PSI)
Sensitivity: Pressure/Turn	E 8.7 Bar (125 PSI) G 17 Bar (248 PSI) J 28 Bar (406 PSI)
Maximum Tank Pressure	420 Bar (6000 PSI)
Leakage at 150 SSU (32 cSt)	25 ml/min. @ 100 Bar (1450 PSI)
Cartridge Material	All parts steel. All operating parts hardened steel.
Operating Temp. Range/Seals	-34°C to +121°C (Nitrile) (-30°F to +250°F) -26°C to +204°C (Fluorocarbon) (-15°F to +400°F)
Fluid Compatibility/Viscosity	Mineral-based or synthetic with lubricating properties at viscosities of 45 to 2000 SSU (6 to 420 cSt)
Filtration	ISO-4406 18/16/13, SAE Class 4
Approx. Weight	0.30 kg (0.66 lbs.)
Cavity	C10-3 (See BC Section for more details)
Form Tool	Rougher NFT10-3R Finisher NFT10-3F

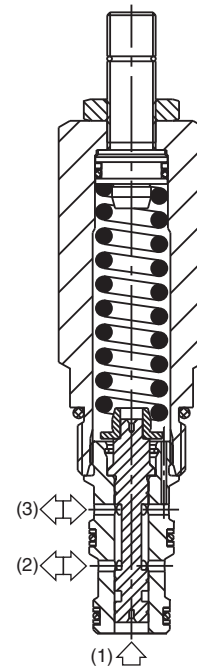
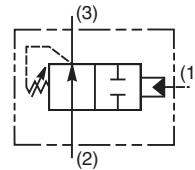
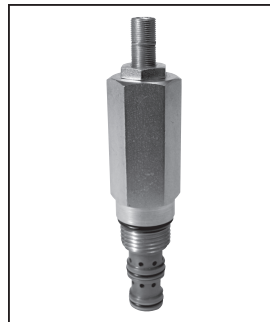

Performance Curves

(Pressure rise through cartridge only)

Flow vs. Inlet Pressure 2 to 3

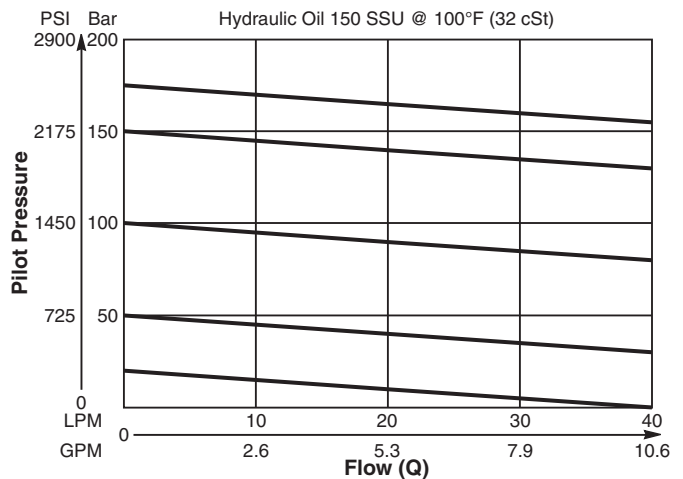

Pressure Drop vs. Flow 2 to 3

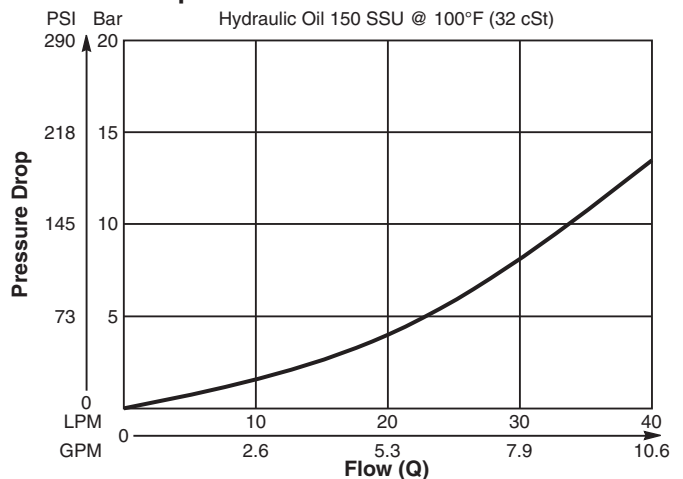

Dimensions Millimeters (Inches)

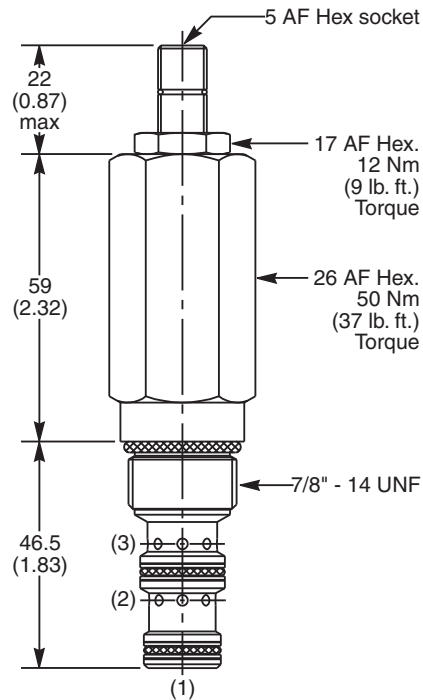

Ordering Information

B04G3	<input type="checkbox"/>	<input type="checkbox"/>	<input type="checkbox"/>	<input type="checkbox"/>	<input type="checkbox"/>	<input type="checkbox"/>	<input type="checkbox"/>	<input type="checkbox"/>
10 Size D.A. Sequence Valve (External Pilot & Internal Drain)	Pilot Pressure Adjustment Range	Adjustment Style	Optional Flow @ Pressure Setting	Pilot Switching Pressure	Seals	Sealed Pilot	Body Material	Port Size

Code	Pilot Pressure Adjustment Range
E	2 - 80 Bar (30 - 1160 PSI)
G	2 - 166 Bar (30 - 2400 PSI)
J	40 - 240 Bar (580 - 3500 PSI)

Code	Adjustment Style / Kit No.
Z	Screw Adjust (Std.)
W	Knob Adjust
T	Tamper Resistant Cap (TC1130)

Optional Flow @ Pressure Setting
If you require a maximum pressure setting at a flow rate, please enter it here in Liters per minute (LPM). Standard setting: 5 LPM (1.3 GPM)

Code	Pilot Switching Pressure
Omit	Omit for no setting (Std.)
B04G3E	Standard Setting: 40 Bar (580 PSI) @ 5 LPM (1.3 GPM)
B04G3G	Standard Setting: 80 Bar (1160 PSI) @ 5 LPM (1.3 GPM)
B04G3J	Standard Setting: 120 Bar (1750 PSI) @ 5 LPM (1.3 GPM)
	Specify setting if required

Code	Seals / Kit No.
N	Nitrile, Buna-N (Std.) / (SK30505N-1)
V	Fluorocarbon / (SK30505V-1)

Code	Sealed Pilot
Omit	Omit if not required
S	Sealed Pilot

Code	Body Material
Omit	Steel
A	Aluminum

Code	Port Size	Body Part No.
Omit	Cartridge Only	
6T	SAE-6	(B10-3-*6T)
8T	SAE-8	(B10-3-*8T)

* Add "A" for aluminum, omit for steel.