

**Technical Information**

- CV** Check Valves
- SH** Shuttle Valves
- LM** Load/Motor Controls
- FC** Flow Controls
- PC** Pressure Controls
- LE** Logic Elements
- DC** Directional Controls
- MV** Manual Valves
- SV** Solenoid Valves
- PV** Proportional Valves
- CE** Coils & Electronics
- BC** Bodies & Cavities
- TD** Technical Data

**General Description**

Kick-Down, Pilot Operated Relief Valve. For additional information see Technical Tips on pages PC1-PC6.

**Features**

- High flow capacity
- Integral 250 micron pilot flow filter
- Hardened working parts for maximum durability
- Adjustable and tamper resistant versions available
- All external parts zinc plated

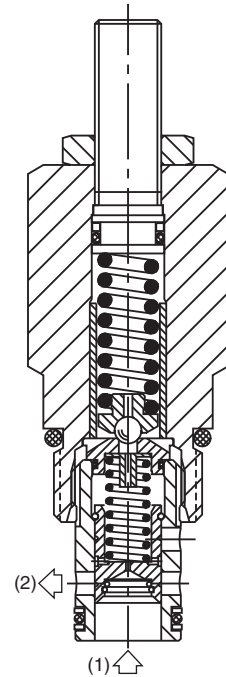
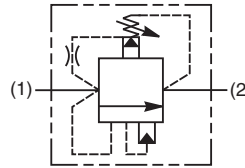
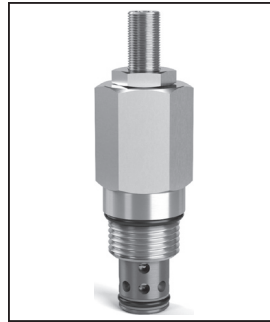

**Specifications**

<b>Rated Flow</b>	160 LPM (42 GPM)
<b>Maximum Inlet Pressure</b>	420 Bar (6000 PSI)
<b>Maximum Pressure Setting</b>	H - 10-210 Bar (145-3000 PSI) P - 10-420 Bar (144-6000 PSI)
<b>Sensitivity: Pressure/Turn</b>	H 30 Bar (435 PSI) P 55 Bar (800 PSI)
<b>Maximum Tank Pressure</b>	420 Bar (6000 PSI)
<b>Leakage at 150 SSU (32 cSt)</b>	25 ml/min. @ 50 Bar (725 PSI)
<b>Cartridge Material</b>	All parts steel. All operating parts hardened steel.
<b>Operating Temp. Range/Seals</b>	-34°C to +121°C (Nitrile) (-30°F to +250°F) -26°C to +204°C (Fluorocarbon) (-15°F to +400°F)
<b>Fluid Compatibility/Viscosity</b>	Mineral-based or synthetic with lubricating properties at viscosities of 45 to 2000 SSU (6 to 420 cSt)
<b>Filtration</b>	ISO-4406 18/16/13, SAE Class 4
<b>Approx. Weight</b>	0.29 kg (0.64 lbs.)
<b>Cavity</b>	C10-2 (See BC Section for more details)
<b>Form Tool</b>	Rougher None Finisher

**Performance Curve**

(Pressure rise through cartridge only)

**Pressure Drop vs. Flow**

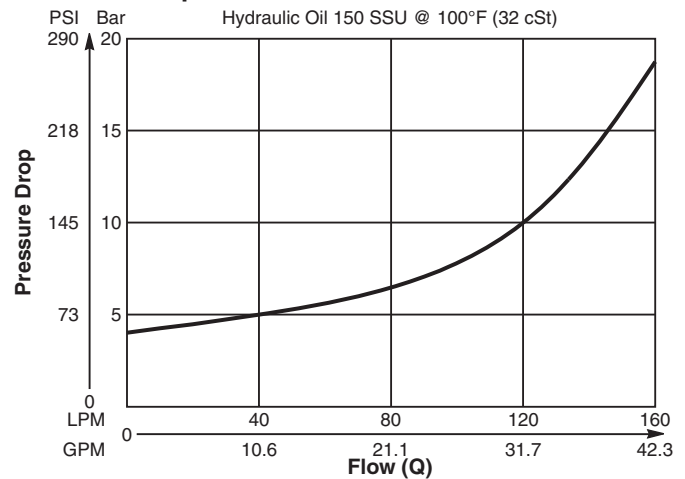

**Application Note**

Valve unloads completely when setting is reached and resets when fluid supply is removed.

**Dimensions** Millimeters (Inches)

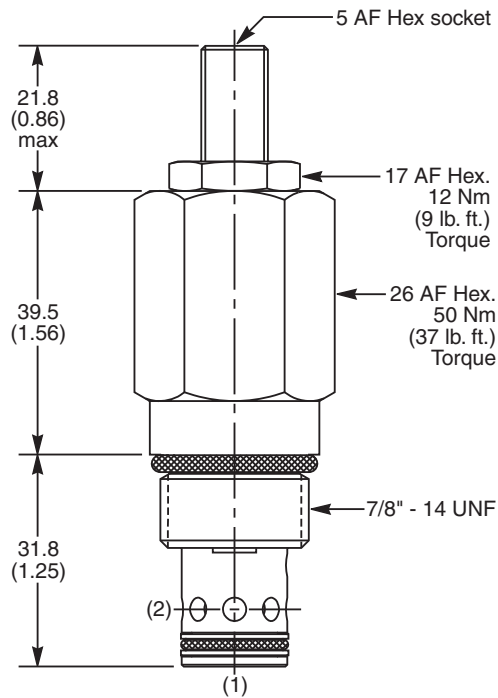

**Ordering Information**

<b>A04K2</b>	<input type="checkbox"/>	<input type="checkbox"/>	<input type="checkbox"/>	<input type="checkbox"/>	<input type="checkbox"/>	<input type="checkbox"/>	<input type="checkbox"/>
<b>10 Size Kick-Down Relief Valve</b>	<b>Pressure Adjustment Range</b>	<b>Adjustment Style</b>	<b>Optional Flow @ Pressure Setting</b>	<b>Optional Pressure Setting</b>	<b>Seals</b>	<b>Body Material</b>	<b>Port Size</b>

Code	Pressure Adjustment Range
H	10 - 210 Bar (145 - 3000 PSI)
P	10 - 420 Bar (145 - 6000 PSI)

Optional Pressure Setting	
Specify setting if required (Bar)	
<b>A04K2H</b> Standard Setting: 100 Bar (1450 PSI)	
<b>A04K2P</b> Standard Setting: 200 Bar (2900 PSI)	

Code	Body Material
Omit	Steel
A	Aluminum

Code	Adjustment Style / Kit No.
Z	Screw Adjust (Std.)
W	Knob Adjust
T	Tamper Resistant Cap (TC1130)

Code	Seals / Kit No.
N	Nitrile, Buna-N (Std.) / (SK30503N-1)
V	Fluorocarbon / (SK30503V-1)

Code	Port Size	Body Part No.
Omit	Cartridge Only	
6T	SAE-6	(B10-2-*6T)
8T	SAE-8	(B10-2-*8T)

\* Add "A" for aluminum, omit for steel.

Optional Flow @ Pressure Setting	
If you require a maximum pressure setting at a flow rate, please enter it here in Liters per minute (LPM).	
Standard setting: 15 LPM (4.0 GPM)	

- CV**  
Check Valves
- SH**  
Shuttle Valves
- LM**  
Load/Motor Controls
- FC**  
Flow Controls
- PC**  
Pressure Controls
- LE**  
Logic Elements
- DC**  
Directional Controls
- MV**  
Manual Valves
- SV**  
Solenoid Valves
- PV**  
Proportional Valves
- CE**  
Coils & Electronics
- BC**  
Bodies & Cavities
- TD**  
Technical Data